



Is Now Part of



ON Semiconductor®

To learn more about ON Semiconductor, please visit our website at
www.onsemi.com

Please note: As part of the Fairchild Semiconductor integration, some of the Fairchild orderable part numbers will need to change in order to meet ON Semiconductor's system requirements. Since the ON Semiconductor product management systems do not have the ability to manage part nomenclature that utilizes an underscore (_), the underscore (_) in the Fairchild part numbers will be changed to a dash (-). This document may contain device numbers with an underscore (_). Please check the ON Semiconductor website to verify the updated device numbers. The most current and up-to-date ordering information can be found at www.onsemi.com. Please email any questions regarding the system integration to Fairchild_questions@onsemi.com.

ON Semiconductor and the ON Semiconductor logo are trademarks of Semiconductor Components Industries, LLC dba ON Semiconductor or its subsidiaries in the United States and/or other countries. ON Semiconductor owns the rights to a number of patents, trademarks, copyrights, trade secrets, and other intellectual property. A listing of ON Semiconductor's product/patent coverage may be accessed at www.onsemi.com/site/pdf/Patent-Marking.pdf. ON Semiconductor reserves the right to make changes without further notice to any products herein. ON Semiconductor makes no warranty, representation or guarantee regarding the suitability of its products for any particular purpose, nor does ON Semiconductor assume any liability arising out of the application or use of any product or circuit, and specifically disclaims any and all liability, including without limitation special, consequential or incidental damages. Buyer is responsible for its products and applications using ON Semiconductor products, including compliance with all laws, regulations and safety requirements or standards, regardless of any support or applications information provided by ON Semiconductor. "Typical" parameters which may be provided in ON Semiconductor data sheets and/or specifications can and do vary in different applications and actual performance may vary over time. All operating parameters, including "Typicals" must be validated for each customer application by customer's technical experts. ON Semiconductor does not convey any license under its patent rights nor the rights of others. ON Semiconductor products are not designed, intended, or authorized for use as a critical component in life support systems or any FDA Class 3 medical devices or medical devices with a same or similar classification in a foreign jurisdiction or any devices intended for implantation in the human body. Should Buyer purchase or use ON Semiconductor products for any such unintended or unauthorized application, Buyer shall indemnify and hold ON Semiconductor and its officers, employees, subsidiaries, affiliates, and distributors harmless against all claims, costs, damages, and expenses, and reasonable attorney fees arising out of, directly or indirectly, any claim of personal injury or death associated with such unintended or unauthorized use, even if such claim alleges that ON Semiconductor was negligent regarding the design or manufacture of the part. ON Semiconductor is an Equal Opportunity/Affirmative Action Employer. This literature is subject to all applicable copyright laws and is not for resale in any manner.



FAN9673 Three-Channel Interleaved CCM PFC Controller

Features

- Continuous Conduction Mode Control
- Three-Channel PFC Control (Maximum)
- Average Current-Mode Control
- PFC Slave Channel Management Function
- Programmable Operation Frequency Range: 18 kHz~40 kHz or 55 kHz~75 kHz
- Programmable PFC Output Voltage
- Two Current Limit Functions
- TriFault Detect™ Protects Against Feedback Loop Failure
- Sag Protection
- Programmable Soft-Start
- Under-Voltage Lockout (UVLO)
- Differential Current Sensing
- Available in 32-Pin LQFP Package

Description

The FAN9673 is an interleaved three-channel Continuous Conduction Mode (CCM) Power Factor Correction (PFC) controller IC intended for PFC pre-regulators. Incorporating circuits for the implementation of leading edge, average current, and “boost”-type power factor correction; the FAN9673 enables the design of a power supply that fully complies with the IEC1000-3-2 specification. Interleaved operation provides substantial reduction in the input and output ripple currents and the conducted EMI filtering becomes easier and cost effective.

An innovative channel management function allows the power level of the slave channels to be loaded and unloaded smoothly according to the setting voltage on the CM pin, improving the PFC converter’s load transient response.

The FAN9673 also incorporates a variety of protection functions, including: peak current limiting, input voltage brown out protection, and TriFault Detect™ function.

Applications

- High Power AC-DC Power Supply
- DC Motor Power Supply
- White Goods; e.g. Air Conditioner Power Supply
- Server and Telecom Power Supply
- UPS
- Industrial Welding and Power Supply

Ordering Information

Part Number	Operating Temperature Range	Package	Packing Method
FAN9673Q	-40°C to 105°C	32LD, LQFP, JEDEC MS-026, Variation BBA, 7 mm Square	Tray
FAN9673QX			Tape & Reel

Typical Application

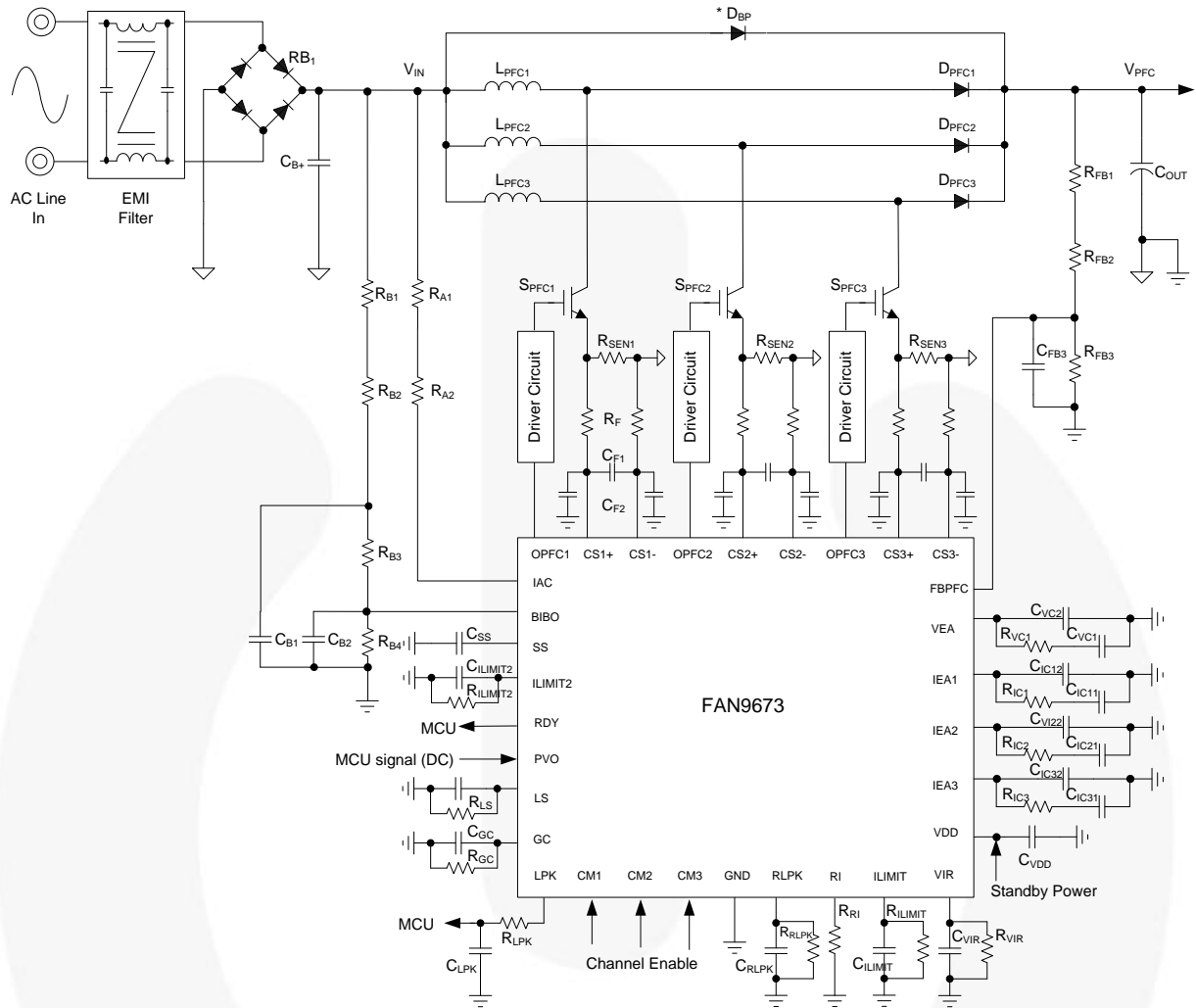

* About D_{BP} please reference System Design Precautions

Figure 1. Typical Application Diagram for Three-Channel PFC Converter

Block Diagram

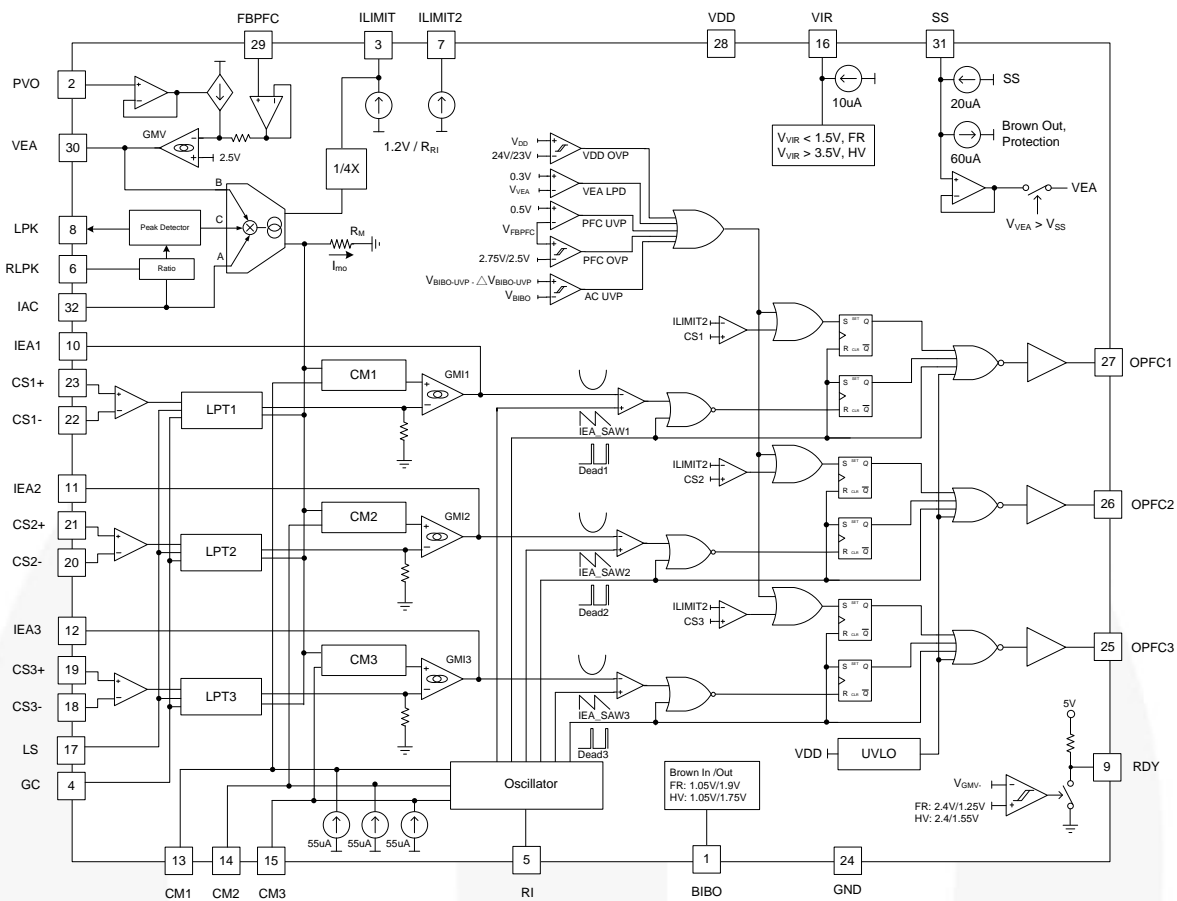

* FR: Full Range AC Input, AC85V~264V
 HV: High Voltage Range AC Input, AC180~264V

Figure 2. Functional Block Diagram

Pin Configuration / Marking Information

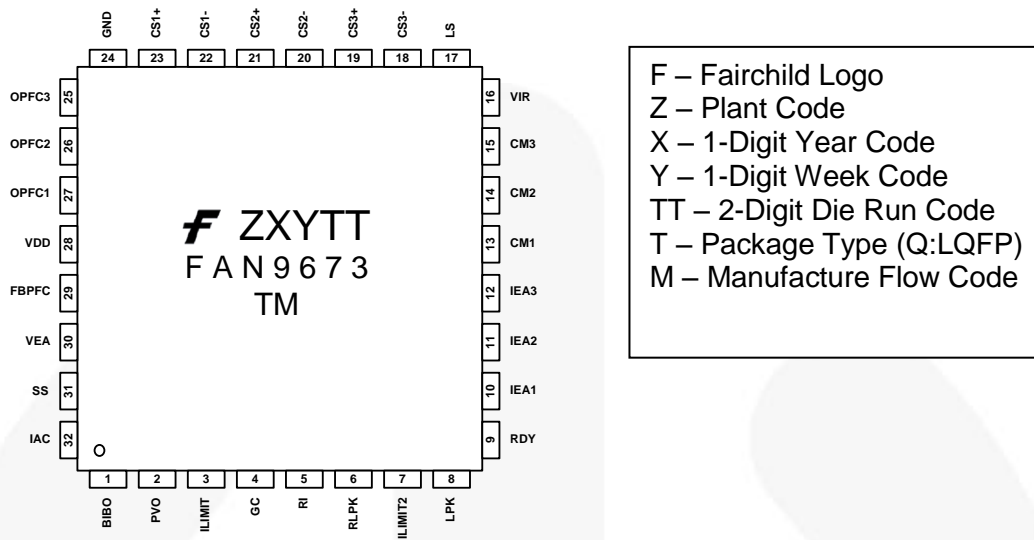

Figure 3. Pin Layout (Top View)

Pin Definitions

Pin #	Name	Description
1	BIBO	Brown In /Out Level Setting. This pin is used for brown in /out setting.
2	PVO	Programmable Output Voltage. DC voltage from a microcontroller (MCU) can be applied to this pin to program the output voltage level. The operation range is 3.5 V ~ 0.5 V. If $V_{PVO} < 0.5$ V, the PVO function is disabled.
3	ILIMIT	Current Command Clamp Setting. Average current mode is to control average value of inductor current by a current command. Connecting a resistor and a capacitor to this pin can determine a limit value of the current command.
4	GC	Setting of Gain Modulator. A resistor, connected from this pin to ground, is used to adjust the output level of the gain modulator. A small capacitor connected from this pin to GND is recommended for noise filtering.
5	RI	Oscillator Setting. There are two oscillator frequency ranges: 18 k~40 kHz and 50 k~75 kHz. A resistor connected from RI to ground determines the switching frequency. A resistor value between 10.6 k ~ 44.4 k Ω is recommended.
6	RLPK	Ratio of V_{LPK} and V_{IN}. Connect a resistor and a capacitor to this pin to adjust the ratio of V_{IN} peak to V_{LPK} . Typical value is 12.4 k Ω (1:100 of V_{LPK} and V_{IN} peak). The accuracy of V_{LPK} is primarily determined by the tolerance of R_{RLPK} at this pin.
7	ILIMIT2	Peak Current Limit Setting. Connect a resistor and a capacitor to this pin to set the over-current limit threshold and to protect power devices from damage due to inductor saturation. This pin sets the over-current threshold for cycle-by-cycle current limit.
8	LPK	Peak of Line Voltage. This pin can be used to provide information about the peak amplitude of the line voltage to an MCU.
9	RDY	Output Ready Signal. When the feedback voltage on FBPFC reaches 2.4 V, the RDY pin outputs a high V_{RDY} signal to inform the MCU that the downstream power stage can start normal operation. If AC brownout is detected, the V_{RDY} signal is LOW to signal to the MCU it is not ready.

Continued on the following page...

Pin Definitions (Continued)

Pin #	Name	Description
10	IEA1	Output 1 of PFC Current Amplifier. The signal from this pin is compared with an internal sawtooth to determine the pulse width for PFC gate drive 1.
11	IEA2	Output 2 of PFC Current Amplifier. The signal from this pin is compared with an internal sawtooth to determine the pulse width for PFC gate drive 2.
12	IEA3	Output 3 of PFC Current Amplifier. The signal from this pin is compared with an internal sawtooth to determine the pulse width for PFC gate drive 3.
13	CM1	Channel 1 Management Setting. This pin is used to configure the characteristic of PFC enable / disable. "PFC Enabling" pull voltage on this pin is LOW (=0 V) to enable and HIGH (>4 V) to disable the whole PFC system.
14	CM2	Channel 2 Management Setting. There are two control methods for channel 2. The first uses an external signal to enable / disable channel 2 ($V_{CM2} = 0\text{ V}$ / $V_{CM2} > 4\text{ V}$). The second is linear increase / decrease loading of channel 2 when power level, V_{VEA} , triggers the setting level of V_{CM2} .
15	CM3	Channel 3 Management Setting. There are two control methods for channel 3. The first uses an external signal to enable / disable channel 3 ($V_{CM3} = 0\text{ V}$ / $V_{CM3} > 4\text{ V}$). The second is linear increase / decrease loading of channel 3 when power level, V_{VEA} , triggers the setting level of V_{CM3} .
16	VIR	Input Voltage Range Setting. A capacitor and a resistor are connected in parallel from this pin to GND. When $V_{VIR} > 3.5\text{ V}$, the PFC controller only works for the high-voltage input range (180 V _{AC} ~ 264 V _{AC}) and R_{IAC} must be 12 M Ω . When $V_{VIR} < 1.5\text{ V}$, the PFC controller works for the full line voltage range (90 V _{AC} ~ 264 V _{AC}) and R_{IAC} must be 6 M Ω . Voltage 1.5 V to 3.5 V is not allowed.
17	LS	Setting for Current Predict Function. A resistor, connected from this pin to ground, is used to adjust the compensation of the linear predict function (LPT). A small capacitor connected from this pin to GND is recommended for noise filtering.
18	CS3-	Negative PFC Current Sense3 Input
19	CS3+	Positive PFC Current Sense3 Input
20	CS2-	Negative PFC Current Sense2 Input
21	CS2+	Positive PFC Current Sense2 Input
22	CS1-	Negative PFC Current Sense1 Input
23	CS1+	Positive PFC Current Sense1 Input
24	GND	Ground
25	OPFC3	PFC Gate Drive 3. The totem-pole output drive for the PWM MOSFET or IGBT. This pin has an internal 15 V clamp to protect the external power switch.
26	OPFC2	PFC Gate Drive 2. The totem-pole output drive for the PWM MOSFET or IGBT. This pin has an internal 15 V clamp to protect the external power switch.
27	OPFC1	PFC Gate Drive 1. The totem-pole output drive for the PWM MOSFET or IGBT. This pin has an internal 15 V clamp to protect the external power switch.
28	VDD	External Bias Supply for the IC. The typical turn-on and turn-off threshold voltages are 12.8 V and 10.8 V, respectively.
29	FBPFC	Voltage Feedback Input for PFC. Inverting input of the PFC error amplifier. This pin is connected to the PFC output through a resistor divider network.
30	VEA	Output of PFC Voltage Amplifier. The error amplifier output for the PFC voltage feedback loop. A compensation network is connected between this pin and ground.
31	SS	Soft-Start. Connect a capacitor to this pin to set the soft-start time. Pull this pin to ground to disable the gate drive outputs OPFC1, OPFC2, and OPFC3.
32	IAC	Input AC Current. During normal operation, this input provides a current reference for the multiplier. The recommended maximum current on IAC, I_{AC} , is 100 μA .

Absolute Maximum Ratings

Stresses exceeding the absolute maximum ratings may damage the device. The device may not function or be operable above the recommended operating conditions and stressing the parts to these levels is not recommended. In addition, extended exposure to stresses above the recommended operating conditions may affect device reliability. The absolute maximum ratings are stress ratings only.

Symbol	Parameter	Min.	Max.	Unit
V _{DD}	DC Supply Voltage		30	V
V _{OPFC}	Voltage on OPFC1, OPFC2, OPFC3 Pins	-0.3	V _{DD} +0.3 V	V
V _L	Voltage on IAC, BIBO, LPK, RLPK, FBPF, VEA, CS1+, CS2+, CS3+, CS1-, CS2-, CS3-, CM1, CM2, CM3, ILIMIT, ILIMIT2, RI, PVO, GC, LS, VIR Pins	-0.3	7.0	V
V _{IEA}	Voltage on IEA1, IEA2, IEA3, SS Pins	0	8	V
I _{IAC}	Input AC Current		1	mA
I _{PFC-OPFC}	Peak PFC OPFC Current, Source or Sink		0.5	A
P _D	Power Dissipation, T _A < 50°C		1640	mW
R _{θj-a}	Thermal Resistance (Junction-to-Air)		77	°C/W
T _J	Operating Junction Temperature	-40	150	°C
T _{STG}	Storage Temperature Range	-55	150	°C
T _L	Lead temperature (Soldering)		260	°C
ESD	Electrostatic Discharge Capability	Human Body Model, ANSI/ESDA/JEDEC JS-001-2012	4	kV
		Charged Device Model, JESD22-C101	2	

Recommended Operating Conditions

The recommended operating conditions table defines the conditions for actual device operation. Recommended operating conditions are specified to ensure optimal performance to the datasheet specifications. Fairchild does not recommend exceeding them or designing to absolute maximum ratings.

Symbol	Parameter	Min.	Typ.	Max.	Unit
V _{DD-OP}	Operating Voltage		15		V
L _{MISMATCH}	Boost Inductor Mismatch	-5		+5	%

Notes:

- All voltage values, except differential voltage, are given with respect to GND pin.
- Stresses beyond those listed under Absolute Maximum Ratings may cause permanent damage to the device.

Electrical Characteristics

Unless otherwise noted, $V_{DD} = 15\text{ V}$ and $T_J = -40\sim 105^\circ\text{C}$.

Symbol	Parameter	Condition	Min.	Typ.	Max.	Unit
VDD Section						
$I_{DD\text{-}ST}$	Startup Current	$V_{DD} = V_{TH\text{-}ON} - 0.1\text{ V}$		30	80	μA
$I_{DD\text{-}OP}$	Operating Current	$V_{DD} = 14\text{ V}$; Output Not Switching, $R_{RI} = 25\text{ k}\Omega$	4	6	7	mA
$V_{TH\text{-}ON}$	Turn-On Threshold Voltage	V_{DD} Rising		12.8		V
ΔV_{TH}	UVLO Hysteresis		2		3	V
$V_{DD\text{-}OVP}$	V_{DD} OVP Threshold	OPFC1~3 Disabled, IEA1~3 and SS Pull LOW	23	24	25	V
$\Delta V_{DD\text{-}OVP}$	V_{DD} OVP Hysteresis			1		V
$t_{D\text{-}OVP}$	V_{DD} OVP Debounce Time				80	μs
Oscillator⁽³⁾						
V_{RI}	Voltage on RI	$R_{RI} = 25\text{ k}\Omega$	1.15	1.20	1.25	V
f_{OSC1}	PFC Frequency of R_{RI} is 25 $\text{k}\Omega$	$R_{RI} = 25\text{ k}\Omega$	30	32	34	kHz
f_{OSC2}	PFC Frequency of R_{RI} is 62 $\text{k}\Omega$	$R_{RI} = 12.5\text{ k}\Omega$	58	62	66	kHz
f_{DV}	Voltage Stability	$13\text{ V} \leq V_{DD} \leq 22\text{ V}$			2	$\%$
f_{DT}	Temperature Stability				2	$\%$
$\Delta V_{IEA\text{-}SAW32}$	$V_{IEA\text{-}SAW}$ of PFC Frequency 32 kHz	$R_{RI} = 25\text{ k}\Omega$		5		V
$\Delta V_{IEA\text{-}SAW64}$	$V_{IEA\text{-}SAW}$ of PFC Frequency 64 kHz	$R_{RI} = 12.5\text{ k}\Omega$		5.15		V
$D_{PFC\text{-}MAX}$	Maximum Duty Cycle	$V_{IEA} > 7\text{ V}$	94	97		$\%$
$D_{PFC\text{-}MIN}$	Minimum Duty Cycle	$V_{IEA} < 1\text{ V}$			0	$\%$
f_{RANGE1}	Frequency Range 1 ^(3,6)		18		40	kHz
f_{RANGE2}	Frequency Range 2 ^(3,6)		55		75	kHz
$t_{DEAD\text{-}MIN}$	Minimum Dead Time	$R_{RI} = 10.7\text{ k}\Omega$		600		ns
VIR						
$V_{VIR\text{-}H}$	Setting Level for High Voltage Input Range	$R_{VIR} = 500\text{ k}\Omega$ ($V_{VIR} = 5\text{ V}$)	3.5			V
$V_{VIR\text{-}L}$	Setting Level for Low Voltage Input Range or Full Voltage Input Range	$V_{VIR} = 0\text{ V}$			1.5	V
I_{VIR}	Source Current of VIR Pin		7	10	13	μA
PFC Soft-Start						
I_{SS}	Constant Current Output for Soft-Start	System Brown-in		22		μA
V_{SS}	Maximum Voltage on SS		6.8			V
$I_{SS\text{-}Discharge}$	Discharge Current of SS Pin	Brownout, SAG, $CM1 > 4\text{ V}$, R_{RI} Open / Short, OTP		60		μA
Low-Power Detect Comparator						
$V_{VEA\text{-}OFF}$	VEA Voltage Off	When $V_{VEA\text{-}OFF} < 0.3\text{ V}$, $V_{OPFC1\text{-}3}$ Turns Off & $V_{IEA1\text{-}3}$ Pulls LOW		0.3		V

Continued on the following page...

Electrical Characteristics

Unless otherwise noted, $V_{DD} = 15\text{ V}$ and $T_J = -40\sim 105^\circ\text{C}$.

Symbol	Parameter	Condition	Min.	Typ.	Max.	Unit
Voltage Error Amplifier						
V_{REF}	Reference Voltage	$PVO = GND, T_J = 25^\circ\text{C}$	2.45	2.50	2.55	V
A_V	Open-Loop Gain ⁽³⁾		42	65		dB
G_{mV}	Transconductance	$V_{NONINV} - V_{INV} = 0.5\text{ V}, T_J = 25^\circ\text{C}$		100		μmho
$I_{FBPFC-L}$	Maximum Source Current	$V_{FBPFC} = 2\text{ V}, V_{VEA} = 3\text{ V}$	40	50		μA
$I_{FBPFC-H}$	Maximum Sink Current	$V_{FBPFC} = 3\text{ V}, V_{VEA} = 3\text{ V}$		-50	-40	μA
I_{BS}	Input Bias Current Range		-1		1	μA
$I_{FBPFC-FL}$	Pull HIGH Current for FBPFC	FBPFC Floating		500		nA
V_{VEA-H}	Output High Voltage on V_{VEA}	$V_{FBPFC} = 2\text{ V}$	5.7	6.0		V
V_{VEA-L}	Output Low Voltage on V_{VEA}	$V_{FBPFC} = 3\text{ V}$		0	0.15	V
$I_{VEA-DIS}$	Discharge Current	Brownout, R_{RI} Open /Short, OTP, SAG		10		μA
Current Error Amplifier 1~3						
G_{mi}	Transconductance	$V_{NONINV} = V_{INV}, V_{IEA} = 4\text{ V}, V_{LIMIT} > 0.6\text{ V}, T_J = 25^\circ\text{C}$		88		μmho
V_{OFFSET}	Input Offset Voltage	$V_{VEA} = 0.45\text{ V}, R_{IAC} = 12\text{ M}\Omega, V_{IAC} = 311\text{ V}, V_{FBPFC} = 2\text{ V}, V_{VIR} = 5\text{ V}, T_J = 25^\circ\text{C}$		0		mV
V_{IEA-H}	Output High Voltage		6.8	7.0		V
V_{IEA-L}	Output Low Voltage			0	0.4	V
I_L	Source Current	$V_{NONINV} - V_{INV}, = +0.6\text{ V}, V_{IEA} = 1\text{ V}, V_{LIMIT} > 0.6\text{ V}$	35	50		μA
I_H	Sink Current	$V_{NONINV} - V_{INV}, = -0.6\text{ V}, V_{IEA} = 6.5\text{ V}, V_{LIMIT} > 0.6\text{ V}$		-50	-35	μA
A_I	Open-Loop Gain ⁽³⁾		40	50		dB
$I_{IEA-LOW}$	IEA Pin Pull LOW Capability Protection	$V_{IEA} \geq 5\text{ V}$	500			μA
Brown In /Out						
$V_{BIBO-FL}$	Low Threshold of BO at Full Range AC Input	$V_{VIR} < 1.5\text{ V}, R_{IAC} = 6\text{ M}\Omega$	1.00	1.05	1.10	V
ΔV_{BIBO-F}	Hysteresis	$V_{BIBO} > V_{BIBO-FL} + \Delta V_{BIBO-F}$, System Brown-in, Start SS		850		mV
$V_{BIBO-HL}$	Low Threshold of BO at High Voltage Single Range AC Input	$V_{VIR} > 3.5\text{ V}, R_{IAC} = 12\text{ M}\Omega$	1.00	1.05	1.10	V
ΔV_{BIBO-H}	Hysteresis	$V_{BIBO} > V_{BIBO-HL} + \Delta V_{BIBO-H}$, System Brown-in, Start SS		700		mV
t_{UVP}	Under-Voltage Protection Delay			450		ms
TriFault Detect™						
$V_{PFC-UVP}$	PFC Feedback Under-Voltage Protection		0.4	0.5	0.6	V
$V_{PFC-OVP}$	Over-Voltage Protection		2.70	2.75	2.80	V
$\Delta V_{PFC-OVP}$	PFC OVP Hysteresis		200	250	300	mV
$t_{FBPFC-OPEN}$	FBPFC Open Delay ⁽³⁾	$V_{FBPFC} = V_{PFC-UVP}$ to FBPFC Open, 470 pF from FBPFC to GND		2		ms
$t_{FBPFC-UVP}$	Under-Voltage Protection Debounce Time			50		μs

Continued on the following page...

Electrical Characteristics

Unless otherwise noted, $V_{DD} = 15\text{ V}$ and $T_J = -40\sim 105^\circ\text{C}$.

Symbol	Parameter	Condition	Min.	Typ.	Max.	Unit
PFC I_{LIMIT2} (CS1 /CS2 /CS3)						
$V_{ILIMIT2-CS1}$	Peak Current Limit Voltage	$CS1 > V_{ILIMIT2}$, OPFC1 Disables Cycle by Cycle Limit, $V_{IEA1\sim 3}$ Pull LOW, $R_{ILIMIT2} = 30\text{ k}\Omega$, $R_{RI} = 25\text{ k}\Omega$		1.48		V
$V_{ILIMIT2-CS2}$	Peak Current Limit Voltage	$CS2 > V_{ILIMIT2}$, OPFC2 Disables Cycle by Cycle Limit, $V_{IEA1\sim 3}$ Pull LOW, $R_{ILIMIT2} = 30\text{ k}\Omega$, $R_{RI} = 25\text{ k}\Omega$		1.48		V
$V_{ILIMIT2-CS3}$	Peak Current Limit Voltage	$CS3 > V_{ILIMIT2}$, OPFC3 Disables Cycle by Cycle Limit, $V_{IEA1\sim 3}$ Pull LOW, $R_{ILIMIT2} = 30\text{ k}\Omega$, $R_{RI} = 25\text{ k}\Omega$		1.48		V
I_{LIMIT2}	Output Current for Peak Current Limit Setting	$R_{RI} = 25\text{ k}\Omega$, V_{RI}/R_{RI} , $T_J = 25^\circ\text{C}$		49.5		μA
$t_{PFC-Bnk1}$	Leading-Edge Blanking Time of ILIMIT of Channel 1	$V_{DD} = 15\text{ V}$, OPFC Drops to 9 V		250		ns
$t_{PFC-Bnk2}$	Leading-Edge Blanking Time of ILIMIT of Channel 2	$V_{DD} = 15\text{ V}$, OPFC Drops to 9 V		250		ns
$t_{PFC-Bnk3}$	Leading-Edge Blanking Time of ILIMIT of Channel 3	$V_{DD} = 15\text{ V}$, OPFC Drops to 9 V		250		ns
t_{PD1}	Propagation Delay to Output of Channel 1			200	400	ns
t_{PD2}	Propagation Delay to Output of Channel 2			200	400	ns
t_{PD3}	Propagation Delay to Output of Channel 3			200	400	ns
$V_{LIMIT-OPEN}$	LIMIT Open Voltage	OPFC1~3 Disabled and IEA1~3 Pull LOW	3.8	4.0	4.2	V
ILIMIT (Command Limit)						
$V_{ILIMIT-R}$	Input Range		0.2		0.8	V
V_{ILIMIT}	Over-Power Limit Voltage	$R_{ILIMIT} = 42\text{ k}\Omega$, $R_{RI} = 25\text{ k}\Omega$, $V_{ILIMIT} = R_{ILIMIT} * I_{LIMIT}/4$		0.504		V
I_{LIMIT}	Source Current of ILIMIT Pin	$R_{RI} = 25\text{ k}\Omega$, V_{RI}/R_{RI}		49		μA
SAG Protection Section						
V_{SAG}	SAG Voltage of BIBO	1. $V_{BIBO} < V_{SAG}$ & V_{RDY} HIGH 33 ms, or 2. $V_{BIBO} < V_{SAG}$ & V_{RDY} Low, Brownout,		0.85		V
t_{SAG-DT}	SAG Debounce Time	$V_{BIBO} < V_{SAG}$ & V_{RDY} HIGH		33		ms
Gain Compensation Section						
I_{GC-L1}	Mirror Current of I_{AC} at Full Range AC Input	$V_{VIR} = 0\text{ V}$, $V_{IAC} = 127.28\text{ V}$, $R_{IAC} = 6\text{ M}\Omega$,		20.71		μA
I_{GC-L2}	Mirror Current of I_{AC} at Full Range AC Input	$V_{VIR} = 0\text{ V}$, $V_{IAC} = 311.13\text{ V}$, $R_{IAC} = 6\text{ M}\Omega$,		51.86		μA
I_{GC-HV}	Mirror Current of I_{AC} at High Voltage Single AC Input	$V_{VIR} = 5\text{ V}$, $V_{IAC} = 311.13\text{ V}$, $R_{IAC} = 12\text{ M}\Omega$.		51.86		μA
$I_{GC-OPEN}$	Pull HIGH Current for GC Open			100		nA
$V_{GC-OPEN}$	GC Open Voltage	$V_{GC} > V_{GC-OPEN}$ V_{IEA1} , OPFC1, 2, 3 Blanking	2.85	3.00	3.15	V

Continued on the following page...

Electrical Characteristics

Unless otherwise noted, $V_{DD} = 15\text{ V}$ and $T_J = -40\sim 105^\circ\text{C}$.

Symbol	Parameter	Condition	Min.	Typ.	Max.	Unit
LPK⁽⁷⁾						
V_{LPK-H1}	V_{LPK} on High Voltage Input Range	$V_{IAC} = 311\text{ V}$, $R_{IAC} = 1\text{ M}\Omega$, $V_{VIR} > 3.5\text{ V}$, $R_{LPK} = 12.4\text{ k}\Omega$, $T_J = 25^\circ\text{C}$		3.168		V
V_{LPK-H2}	V_{LPK} on High Voltage Input Range	$V_{IAC} = 373\text{ V}$, $R_{IAC} = 12\text{ M}\Omega$, $V_{VIR} > 3.5\text{ V}$, $R_{LPK} = 12.4\text{ k}\Omega$, $T_J = 25^\circ\text{C}$		3.80		V
V_{LPK-L1}	V_{LPK} on Full Range AC Input	$V_{IAC} = 127\text{ V}$, $R_{IAC} = 6\text{ M}\Omega$, $V_{VIR} < 1.5\text{ V}$, $R_{LPK} = 12.4\text{ k}\Omega$, $T_J = 25^\circ\text{C}$		1.29		V
V_{LPK-L2}	V_{LPK} on Full Range AC Input	$V_{IAC} = 373\text{ V}$, $R_{IAC} = 6\text{ M}\Omega$, $V_{VIR} < 1.5\text{ V}$, $R_{LPK} = 12.4\text{ k}\Omega$, $T_J = 25^\circ\text{C}$		3.80		V
V_{AC-OFF}	AC OFF Threshold Voltage	$R_{IAC} = 12\text{ M}\Omega$, $V_{VIR} > 3.5\text{ V}$, After t_{AC-OFF} V_{IEA} Pull LOW		32		V
V_{AC-ON}	AC ON Threshold Voltage	$R_{IAC} = 12\text{ M}\Omega$, $V_{VIR} > 3.5\text{ V}$		$V_{AC-OFF} + 26$		V
RLPK						
$I_{RLPK-OPEN}$	Pull HIGH Current for RLPK Open			100		nA
$V_{RLPK-OPEN}$	RLPK Open Voltage	RLPK Open	2.28	2.40	2.52	V
PVO						
V_{PVO}	Input Range		0.3		3.5	V
V_{PVO_DIS}	PVO Disable Voltage	$PVO < V_{PVO_DIS}$ Disable		0.2		V
$V_{PVO-CLAMP}$	PVO Limit Voltage	FBPFC Connected to VEA, $V_{PVO} = 4\text{ V}$		1.6		V
V_{FBPFC1}	FBPFC Voltage 1	FBPFC Connected to VEA, $V_{PVO} = 0.3\text{ V}$		2.425		V
V_{FBPFC2}	FBPFC Voltage 2	FBPFC Connected to VEA, $V_{PVO} = 3.5\text{ V}$		1.625		V
$I_{PVO-Discharge}$	PVO Discharge Current	PVO Open		1		μA
OTP						
T_{OTP-ON}	Over-Temperature Protection ⁽³⁾			140		$^\circ\text{C}$
ΔT_{OTP}	Hysteresis ⁽³⁾			30		$^\circ\text{C}$
CM1 Section						
I_{CM1}	CM1 Output Current			55		μA
$V_{CM1-disable}$	PFC Disable Voltage	OPFC1~3 Disabled and IEA1~3 Pull LOW and SS Pull LOW; $I_{CM1} \cdot R_{CM1} > 4\text{ V}$		4		V
θ_1	Phase of OPFC1	When $I_{CM1} \cdot R_{CM1} < 4\text{ V}$ or Short		0		$^\circ$
θ_2	Phase of OPFC2	When $I_{CM1} \cdot R_{CM1} < 4\text{ V}$ or Short	110	120	130	$^\circ$
θ_3	Phase of OPFC3	When $I_{CM1} \cdot R_{CM1} < 4\text{ V}$ or Short	230	240	250	$^\circ$
CM2 Section						
I_{CM2}	CM2 Output Current			55		μA
$V_{CM2-disable}$	Channel2 Disable Voltage	OPFC2 Disables and IEA2 Pulls LOW; $I_{CM2} \cdot R_{CM2} > 4\text{ V}$ or CM2 Floating		4		V
$V_{CM2-range}$	Set VEA Unload Voltage		0		3.8	V
θ_1	Phase of OPFC1	$I_{CM2} \cdot R_{CM2} > 4\text{ V}$ or CM2 Floating		0		$^\circ$
θ_3	Phase of OPFC3	$I_{CM2} \cdot R_{CM2} > 4\text{ V}$ or CM2 Floating	170	180	190	$^\circ$

Continued on the following page...

Electrical Characteristics

Unless otherwise noted, $V_{DD} = 15\text{ V}$ and $T_J = -40\sim 105^\circ\text{C}$.

Symbol	Parameter	Condition	Min.	Typ.	Max.	Unit
CM3 Section						
I_{CM3}	CM3 Output Current			55		μA
$V_{CM3\text{-disable}}$	Channel3 Disable Voltage	OPFC3 Disables and IEA3 Pulls LOW when $I_{CM3} * R_{CM3} > 4\text{ V}$ or CM3 Floating		4		V
$V_{CM3\text{-range}}$	Set VEA Unload Voltage		0		3.8	V
θ_1	Phase of OPFC1	When $I_{CM3} * R_{CM3} > 4\text{ V}$ or CM3 Floating		0		$^\circ$
θ_2	Phase of OPFC2	When $I_{CM3} * R_{CM3} > 4\text{ V}$ or CM3 Floating	170	180	190	$^\circ$
RDY Section						
$V_{FB\text{-RD}}$	Level of V_{FBPFC} to Pull RDY HIGH	$V_{PVO} = 0\text{ V}$, Brown-in, $V_{FBPFC} > V_{FB\text{-RD}}$	2.3	2.4	2.5	V
$\Delta V_{FB\text{-RD-L}}$	Hysteresis	$V_{PVO} = 0\text{ V}$, $V_{IR} < 1.5\text{ V}$		1.15		V
$\Delta V_{FB\text{-RD-H}}$	Hysteresis	$V_{PVO} = 0\text{ V}$, $V_{IR} > 3.5\text{ V}$		0.85		V
Z_{RDY}	Pull High Input Impedance	$T_J = 25^\circ\text{C}$		100		$\text{k}\Omega$
$V_{RDY\text{-High}}$	HIGH Voltage of RDY		4.8	5.0		V
$V_{RDY\text{-Low}}$	LOW Voltage of RDY	Pull High Current = 1 mA			0.5	V
PFC Output Driver1~3						
$V_{GATE\text{-CLAMP}}$	Gate Output Clamping Voltage	$V_{DD} = 22\text{ V}$	13	15	17	V
$V_{GATE\text{-L}}$	Gate Low Voltage	$V_{DD} = 15\text{ V}$; $I_O = 100\text{ mA}$			1.5	V
$V_{GATE\text{-H}}$	Gate High Voltage	$V_{DD} = 13\text{ V}$; $I_O = 100\text{ mA}$	8			V
t_r	Gate Rising Time	$V_{DD} = 15\text{ V}$; $C_L = 4.7\text{ nF}$; O/P = 2 V to 9 V		70		ns
t_f	Gate Falling Time	$V_{DD} = 15\text{ V}$; $C_L = 4.7\text{ nF}$; O/P = 9 V to 2 V		60		ns
LPT Section						
R_{LS}	Range of Inductance Setting		12		87	$\text{k}\Omega$
$V_{LS\text{-MIN}}$	Voltage Difference between V_{FBPFC} and V_{ACD} on LS Pin	$V_{FBPFC} - V_{ACD} \geq 0\text{ V}$		50		mV
Gain Modulator						
I_{AC}	Input for AC Current ^(3,6)	Multiplier Linear Range	0		65	μA
BW	Bandwidth ^(3,6)	$I_{AC} = 40\text{ }\mu\text{A}$		2		kHz

Continued on the following page...

Electrical Characteristics

Unless otherwise noted, $V_{DD} = 15\text{ V}$ and $T_J = -40\sim 105^\circ\text{C}$.

Symbol	Parameter	Condition	Min.	Typ.	Max.	Unit
V_{RM}	Voltage of R_M (Output Current of Gain Modulator * R_M)	$V_{IAC} = 106.07\text{ V}$, $R_{IAC} = 6\text{ M}\Omega$, $V_{FBPFC} = 2.25\text{ V}$, $V_{BIBO} = 2\text{ V}$, V_{CM2} , $V_{CM3} > 4.5\text{ V}$ ($V_{AC} = 75\text{ V}$), $T_J = 25^\circ\text{C}$		0.490		V
		$V_{IAC} = 120.21\text{ V}$, $R_{IAC} = 6\text{ M}\Omega$, $V_{FBPFC} = 2.25\text{ V}$, $V_{BIBO} = 2\text{ V}$, V_{CM2} , $V_{CM3} > 4.5\text{ V}$ ($V_{AC} = 85\text{ V}$), $T_J = 25^\circ\text{C}$		0.430		
		$V_{IAC} = 155.56\text{ V}$, $R_{IAC} = 6\text{ M}\Omega$, $V_{FBPFC} = 2.25\text{ V}$, $V_{BIBO} = 2\text{ V}$, V_{CM2} , $V_{CM3} > 4.5\text{ V}$ ($V_{AC} = 110\text{ V}$), $T_J = 25^\circ\text{C}$		0.327		
		$V_{IAC} = 311.13\text{ V}$, $R_{IAC} = 12\text{ M}\Omega$, $V_{FBPFC} = 2.25\text{ V}$, $V_{BIBO} = 2\text{ V}$, V_{CM2} , $V_{CM3} > 4.5\text{ V}$, $V_{VIR} > 3.5\text{ V}$ ($V_{AC} = 220\text{ V}$), $T_J = 25^\circ\text{C}$		0.320		
		$V_{IAC} = 373.35\text{ V}$, $R_{IAC} = 12\text{ M}\Omega$, $V_{FBPFC} = 2.25\text{ V}$, $V_{BIBO} = 2\text{ V}$, V_{CM2} , $V_{CM3} > 4.5\text{ V}$, $V_{VIR} > 3.5\text{ V}$ ($V_{AC} = 264\text{ V}$), $T_J = 25^\circ\text{C}$		0.260		
R_M	Resistor of Gain Modulator Output	$R_M = V_{RM}/I_{MO}$		7.5		k Ω

Notes:

3. This parameter, although guaranteed by design, is not 100% production tested.
4. The setting range of resistance at the RI pin is between 53.3 k Ω and 10.7 k Ω .
5. The R_{LS} and R_{GC} setting suggestion follows the calculation result from Fairchild documents: AN-4164, AN-4165, FEBFAN9673_B01H1500A, FEBFAN9673_B01H2500A, and design tools.
6. Frequency of AC input should be <75 Hz.
7. LPK specification is guaranteed at state of PFC working.
8. Pull the CM pin low to ground to enable an individual channel for voltage of CM pin less than 0.2 V.

Theory of Operation

1. Continuous Conduction Mode (CCM)

The boost converter, shown in Figure 4, is the most popular topology for power factor correction in AC-DC power supplies. This popularity can be attributed to the continuous input current waveform provided by the boost inductor and the boost converter's input voltage range including 0 V. These fundamental properties make close-to-unity power factor easier to achieve.

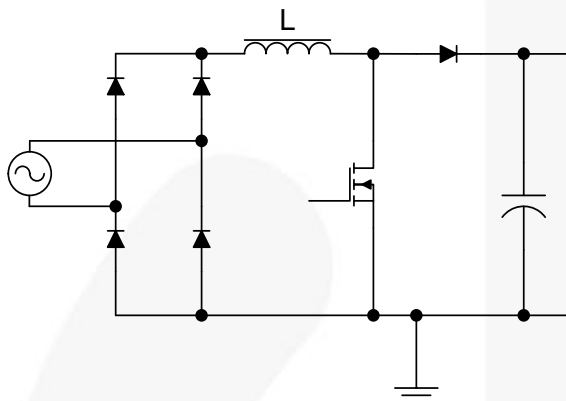

Figure 4. Basic PFC Boost Converter

The boost converter can operate in Continuous Conduction Mode (CCM) or in Boundary Conduction Mode (BCM). These two descriptive names refer to the current flowing in the energy storage inductor of the boost power stage.

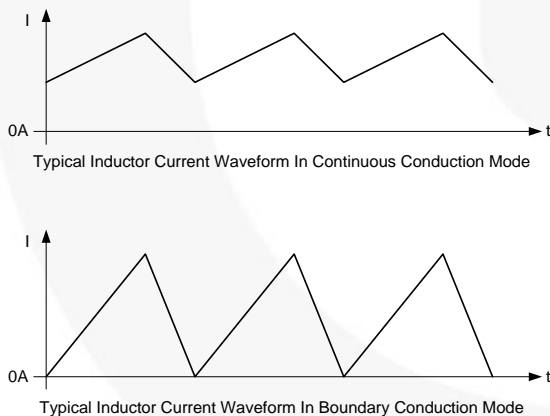

Figure 5. CCM vs. BCM Control

As the names indicate, the current in Continuous Conduction Mode (CCM) is continuous in the inductor. In Boundary Conduction Mode (BCM), the new switching period is initiated when the inductor current returns to zero. There are many fundamental differences in CCM and BCM operations and the respective designs of the boost converter. The FAN9673 is design for CCM control, as Figure 5 shows, this method reduces inductor current ripple because the start current of each cycle is not 0 A typically. The ripple is controlled by the operation frequency and inductance design. This characteristic can decrease the maximum peak current of the power semiconductor device.

2. Gain Modulator (IAC, LPK, VEA)

The FAN9673 employs two control loops for power factor correction: a current control loop and a voltage control loop. The current control loop shapes inductor current, as shown in Figure 6, through a current command, I_{MO} , from the gain modulator.

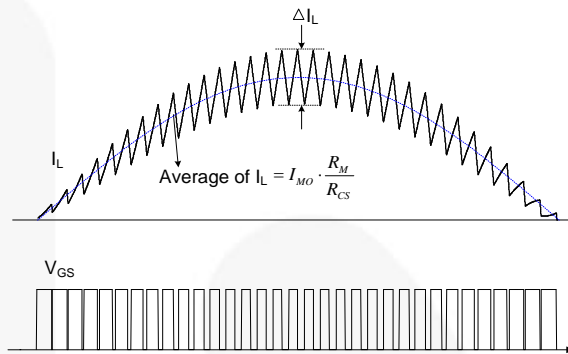

Figure 6. CCM PFC Operation Waveforms

The gain modulator is the block that provides the reference to control PFC output power. The current of the gain modulator, I_{mo} , is a function of V_{VEA} , I_{IAC} , and LPK ; as shown in the Figure 7.

These are the three inputs to the gain modulator:

- I_{IAC} A current representing the instantaneous input voltage (amplitude and wave shape) to the PFC. The rectified AC input sine wave is converted to a proportional current via a resistor and is fed into the gain modulator on I_{IAC} . Sampling current I_{IAC} minimizes ground noise, important in high-power, switching-power conversion environment. The gain modulator responds linearly to this current.
- V_{LPK} Voltage proportional to the peak voltage of the bridge rectifier when the PFC is working. The signal is the output of peak-detect circuit and its input is from the IAC pin. This factor of the gain modulator is input-voltage feed-forward control. This voltage information is not valid when the PFC is not working.
- V_{VEA} The output of the voltage error amplifier, V_{VEA} . The gain modulator responds linearly to variations in this voltage.

The output of the gain modulator is a current signal, I_{MO} , calculated by Equation (1):

$$I_{MO} = K \times \frac{I_{IAC} \times V_{VEA}}{V_{LPK}^2} \quad (1)$$

The current signal, I_{MO} , is in the form of a full-wave rectified sinusoid at twice the line frequency. The gain modulator forms the reference for the current error loop and ultimately controls the instantaneous current drawn from the power line.

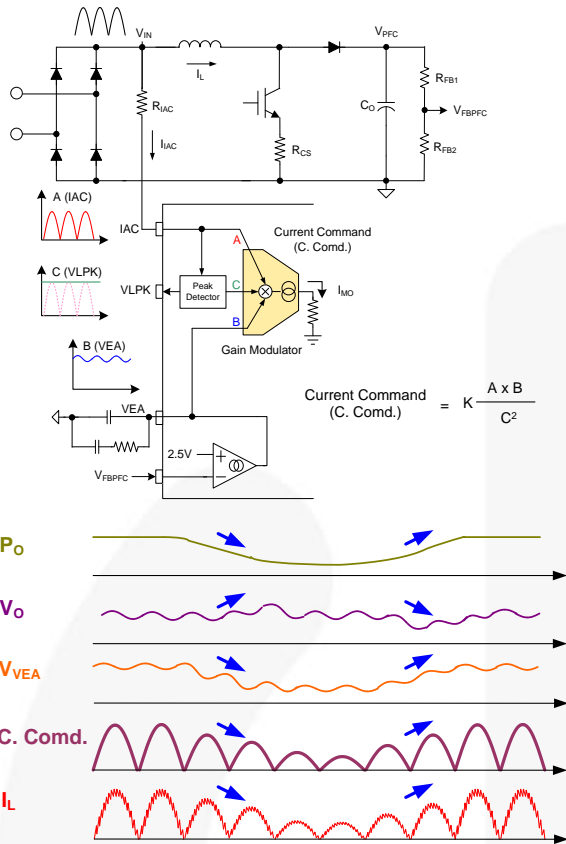

Figure 7. Input of Gain Modulation

3. Current Balance

Current matching of different channel is important topic of interleaved control. There have several main point is need to careful at FAN9673 of this topic.

The current control of each channel is based on sense signal V_{CS} to track the current command of the multiplier, as Figure 8 shows.

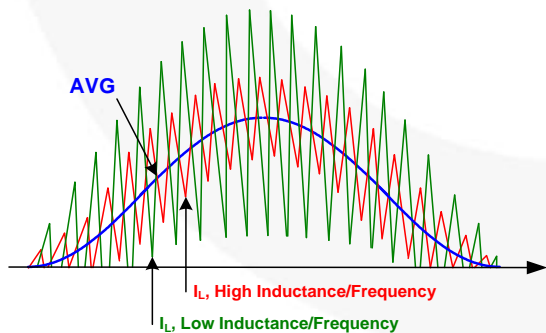

Figure 8. Average Current Mode Control

The main factors to system balance are layout and device tolerance. The tolerance of the shunt resistor for the current sense is especially important. If the feedback signal, V_{CS} , has large deviation due to the tolerance of the sense resistor; the current of the channels is unbalanced. A high precision resistor is necessary.

High-power applications require the system current be large, so the distance of layout trace between the current sense resistors and the controller or power ground (negative of output capacitor) to IC ground is important, as Figure 9 shows. The longer trace and large current make the offset voltage and ground bounce differ significantly for different channels. Decreasing the deviation can balance the different channels. Follow the layout guidance of application notes AN-4164 and AN-4165.

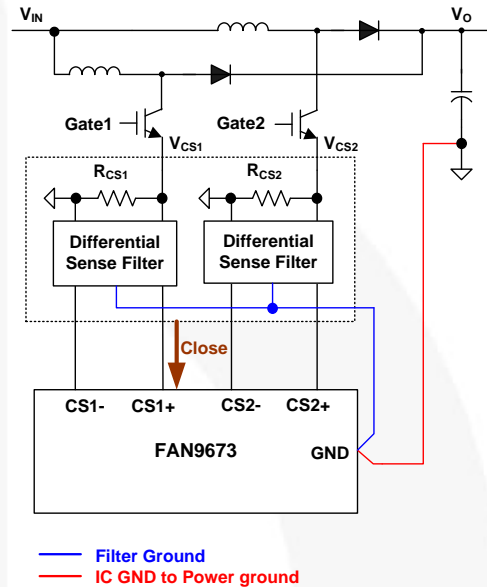

Figure 9. Current Balance Factors

4. Interleaving

The FAN9673 controller is used to control three-channel boost converters connected in parallel. The controller operates in average-current mode and Continuous Conduction Mode (CCM). Each channel affords one-third the power when the system operates close to full load or when channel management is disabled.

Parallel power processing increases the number of power components, but the current rating of independent channels is reduced, allowing power semiconductors with lower current ratings to be applied. With interleaved control, the output current ripple is evenly distributed on channels and sequentially rippled on the output capacitor. Output current ripple is average share to difference sequence to output capacitor, which can extend the life of the capacitor.

The switches of the three boost converters can operate at three-channel / 120° out-of-phase or two-channel / 180° out-of-phase (one channel disable at light load). The interleaving controller can reduce the total ripple current of input. The FAN9673 offers two types of channel management method selectable by the user.

5. Channel Management 2/3: CM Control

The CM pin is used for channel management. The relationship of CM and the gain of the slave channel is shown in Figure 10. The level of CM determines the power level (V_{VEA}) for reducing the output power for the slave PFC. The FAN9673 starts to reduce the current command ($I_{MO} \cdot R_M$) for channel 2/3 by Gain2/3 when the V_{VEA} level is lower than its CM level, as Figure 11 and Figure 12 show. The output power of the slave channel is reduced in response to the reduction in current command. Typical $G_{ain2/3}$ is 1-0. Example: when CM2 is set at 3 V and V_{VEA} is less than the CM2 voltage, the channel management block reduces the command for channel 2 as:

$$V_{gmi2+} = I_{MO} \cdot R_M \cdot G_{ain2} \quad (2)$$

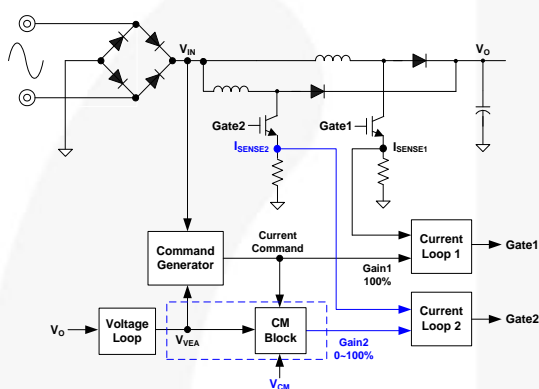

Figure 10. Channel Management / Gain Slave Channel Relationship

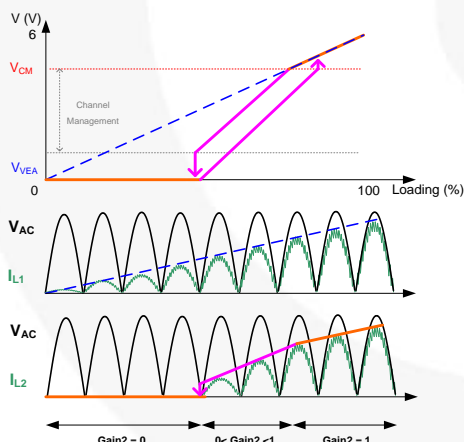

Figure 11. V_{VEA} and Gain2 Relationship

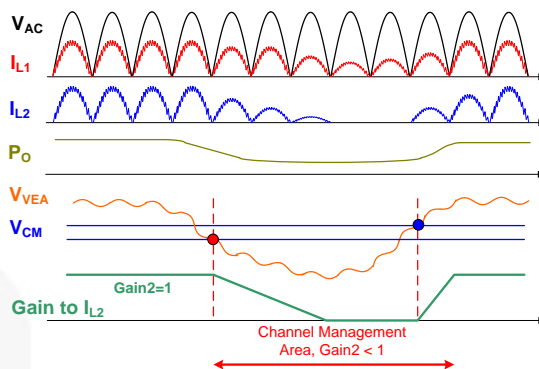

Figure 12. V_{VEA} and V_{CM} Relationship in Channel Management Operation

Table 1 explains the phase and gain change of each channel when the PFC operates at various loads. The loading decreases the gain to the slave until it is disabled. The phase of Channel Management (CM) mode doesn't change when channel 3 is disabled. The behavior is shown in Figure 13.

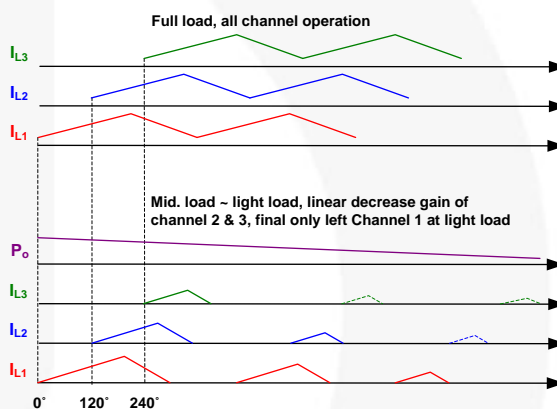

Figure 13. Phase and Gain Change of CM Control

Table 1. Phase and Gain Change of CM Control

CM (Channel Management)	Phase		
	Channel 1	Channel 2	Channel 3
Heavy Load (All Channel 100% Works)	0° (Gain1=1)	120° (Gain2=1)	240° (0<Gain3<1)
Mid. Load (Channel3 Disable)	0° (Gain1=1)	120° (0<Gain2<1)	Disable (Gain3=0)
Light Load (Only Channel1 Left)	0° (Gain1=1)	Disable (Gain2=0)	Disable (Gain3=0)

6. Channel Management 2: External Control

To disable the Channel Management (CM) function and control the channels with an external signal from the MCU, the configuration is shown in Figure 14. If $V_{CM} > 4V$, the channel is disabled. To enable the channel, make $V_{CM} = 0V$, as Figure 15 shows.

The CM pin of the slave should be connected with a switch S_2 to ground. When $V_{VEA} < V_{P2-OFF-L}$, the slave PFC turns off. If $V_{VEA} > V_{P2-OFF-H}$, the slave PFC turns on. One pin of MCU must read the V_{VEA} signal to determine when to turn on / off the slave. ($V_{P2-OFF-L}$ and $V_{P2-OFF-H}$ are hysteresis levels required in MCU software.) When S_2 turns on, CM disables and the slave works normally, as shown in Figure 16.

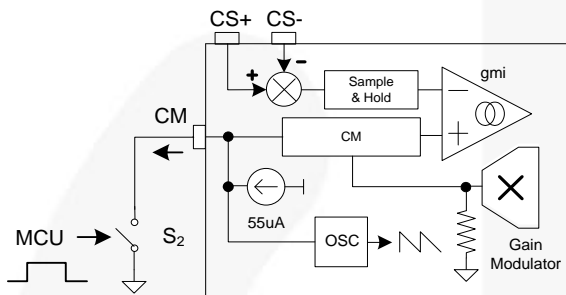

Figure 14. Channel Management by MCU

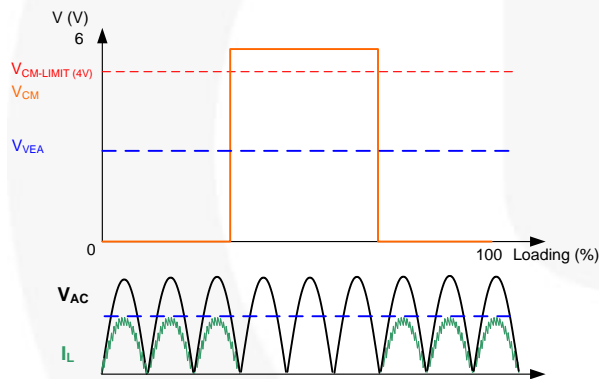

Figure 15. Channel Management by MCU

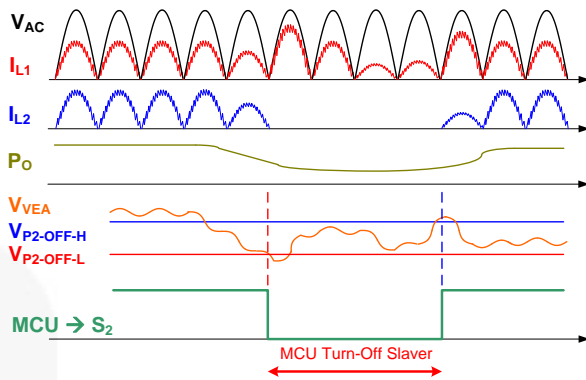

Figure 16. Channel Management by External Signal from MCU

The phase of each channel controlled by external signal control changes when the loading changes, as illustrated in Table 2 and Figure 17. When the MCU disables channel 3 at mid-load, the phase of channel 2 shifts to 180° from 120°. The gain of each channel under this control mode must be 100% or 0%. CM mode makes the gain operation between 1~0.

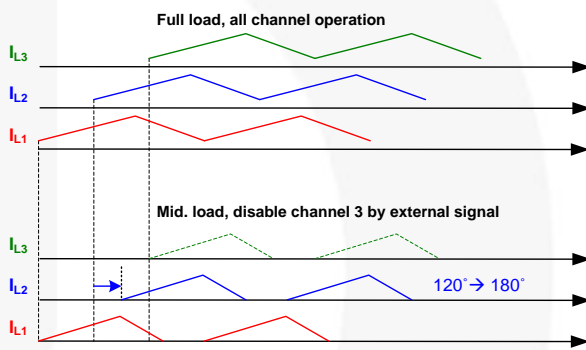

Figure 17. Phase Change under External Signal Control

Table 2. Phase Change of External Signal Control

External Signal Control	Phase (Disable Channel: $V_{CM} > 4V$, Enable Channel: $V_{CM} = 0V$)		
	Channel 1	Channel 2	Channel 3
Heavy Load (All Channels Enabled)	0°	120°	240°
Mid. Load (Channel3 Disabled)	0°	180°	Disable ($V_{CM3} > 4V$)
Light Load (Channel2/3 Disabled)	0°	Disable ($V_{CM2} > 4V$)	Disable ($V_{CM3} > 4V$)
Disable All System	$V_{CM1} > 4V$, All Channels Disabled		

Functional Description

Internal Oscillator (RI)

The internal oscillator frequency is determined by external resistor, R_{RI} , on the RI pin. The frequency of the oscillator is given by:

$$f_{osc} = \frac{8 \times 10^8}{R_{RI}} \quad (3)$$

Current-Control Loop of Boost Stage

As shown in Figure 18, the two control loops for power factor correction are a current-control loop and a voltage-control loop. Based on the reference signal obtained at the IAC pin, the relationship of current loop is:

$$I_L \cdot R_{CS} = I_{MO} \cdot R_M \cdot G_{LU} = I_{IAC} \cdot G \cdot G_{LU} \cdot R_M \quad (4)$$

The current sense, $I_L \cdot R_{CS}$, is controlled by the current command from the multiplier; $I_{MO} \cdot R_M$. I_{MO} is the relationship of three input factors: I_{IAC} , V_{EA} , and LPK . G_{ain2} is a gain between 0~1 from the channel management block for the slave channel.

Voltage-Control Loop of Boost Stage

The voltage-control loop regulates PFC output voltage by using the internal error amplifier, G_{mv} , such that the voltage on FBPF is the same as the internal reference voltage of 2.5 V. This stabilizes PFC output voltage and decreases the 120 Hz ripple of PFC output voltage. PFC Over-Voltage Protection (OVP) protects the power circuit from damage from an excessive voltage at a sudden load change. When the voltage on FBPF exceeds 2.75 V, the PFC output driver shuts down.

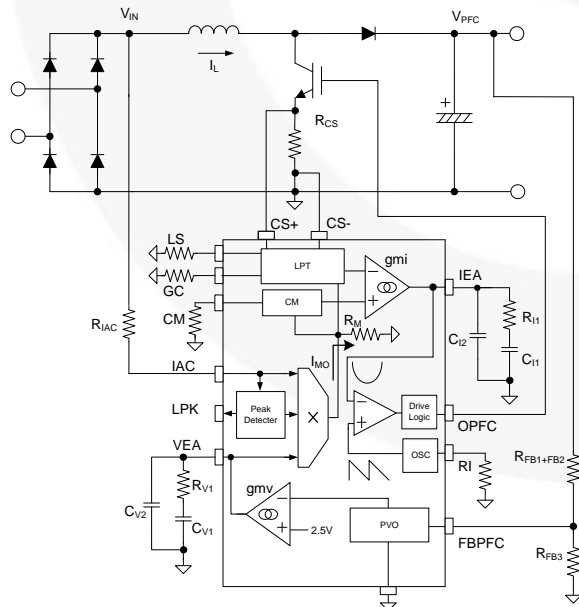

Figure 18. Gain Modulation Block

TriFault Detect™ Technology

To improve power supply reliability, reduce system component count, and simplify compliance to UL 1950 safety standards; the FAN9673 includes TriFault Detect™ technology. This feature monitors FBPF for certain PFC fault conditions.

In the case of a feedback path failure, the output of the PFC can exceed operating limits. Should FBPF go too low, too high, or open; TriFault Detect senses the error and terminates the PFC output drive.

TriFault Detect is an entirely internal circuit. It requires no external components to perform its function.

PFC Over-Voltage Protection (OVP)

FAN9673 has an auto-restart OVP function. When the feedback level, V_{FBPF} , of the PFC reaches 2.75 V (reference level is 2.5 V), the PFC gate signal stops until the output voltage decreases and V_{FBPF} returns to 2.5 V, when the PFC restarts regulation.

Linear Predict Function (GC & LC)

The linear predict function is used to emulate the behavior of inductor current when the MOSFET is off. The resistors of the GC and LS pins (R_{GC} and R_{LS}) are used to adjust the DC gain and compensation, respectively. The resistors are determined by:

$$R_{LS} = \frac{L_{PFC}}{1.5 \times 10^{-9} \times R_{CS} \times \left(\frac{R_{FB1} + R_{FB2} + R_{FB3}}{R_{FB3}} \right)} \quad (5)$$

$$R_{GC} = \frac{6 \times 10^6}{\left(\frac{R_{FB1} + R_{FB2} + R_{FB3}}{R_{FB3}} \right)} \quad (6)$$

PFC Brown In /Out (BIBO)

An internal AC Under-Voltage Protection (UVP) comparator monitors the AC input information from V_{IN} , as Figure 19 shows. The OPFC is disabled when the V_{BIBO} is less than 1.05 V for 410 ms. If V_{BIBO} is larger than 1.9 V / 1.75 V, V_{BIBO} is over 1.9 V / 1.75 V, and the PFC stage is enabled. The V_{IR} pin is used to set the AC input range according to Table 3.

Table 3. BIBO Setting of Various AC Input

Input Range	AC (V)	R_{VIR} Setting	R_{IAC} Setting	BIBO Level (V)
Full-Range	85~ 264	10 kΩ	6 MΩ	85 / 75
HV-Single	180~264	470 kΩ	12 MΩ	170 / 160

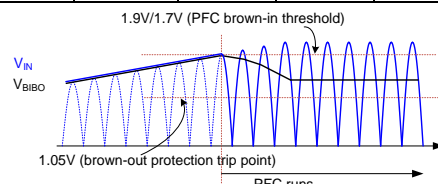

Figure 19. V_{BIBO} According to the PFC Operation

Differential Current Sensing (CS+, CS-)

The FAN9673 has three groups of differential current-sensing pins. The CS_{n+} and CS_{n-} sets of pins are the inputs of the internal differential amplifier. Switching noise problems in interleaved PFC control is more critical than on a single channel, especially for current sensing. The FAN9673 uses a differential amplifier to eliminate switching noise from other channels. This makes the PFC more stable in higher-power applications and eliminates switching noise from other channels. As Figure 20 shows, ground bounce can be decreased by a differential sense function.

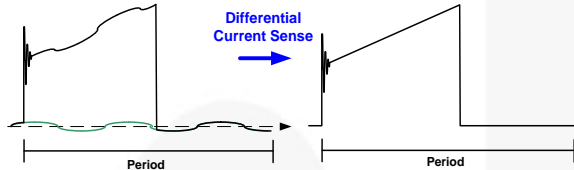

Figure 20. Differential Current Sense

PFC Gate Driver

For high-power applications, the switch device of the system requires high driver current. The totem-pole circuit shown in Figure 21 is recommended.

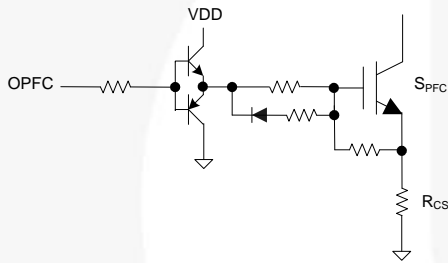

Figure 21. Gate Drive Circuit

Current-Limit Protection

The FAN9673 includes three “cases” of current-limit protection to manage OCP and inductor saturation: V_{VEA}, I_{LIMIT}, and I_{LIMIT2}. The current-limit thresholds, V_{ILIMIT1} and V_{ILIMIT2}, are controlled by the selection of the resistor for the application.

Power (normal state): In the normal case, current / power should be controlled by command V_M from the gain modulator. When V_{VEA} rises to 6 V, the output power and current of the system are at peak. The power and current can't increase further.

Current Limit 1 (abnormal state): The current command from the gain modulator is $k \cdot I_{AC} \cdot V_{VEA} / V_{LPK}^2$. When in abnormal state (e.g. an AC cycle miss and return in a short period), the V_{LPK} has a delay before returning to the original level. This delay significantly increases the current command. If the command is greater than the limit clamp level, V_{ILIMIT}, it works as shown in Figure 22 and Figure 23. The peak current of this state can be used as the maximum current designed for each channel such that inductor current is not saturated.

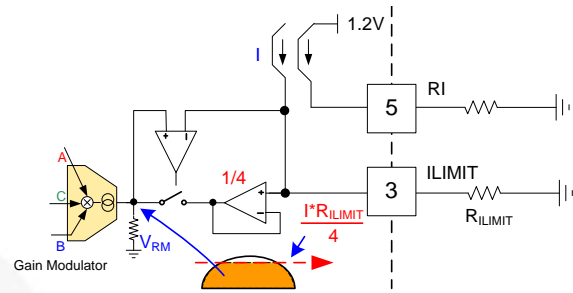

Figure 22. Current Command Limit by ILIMIT

Current Limit 2 (saturation state): Use 80%~90% of the maximum current of the switch device to serve as the saturation protection. This current protection is a cycle-by-cycle limit.

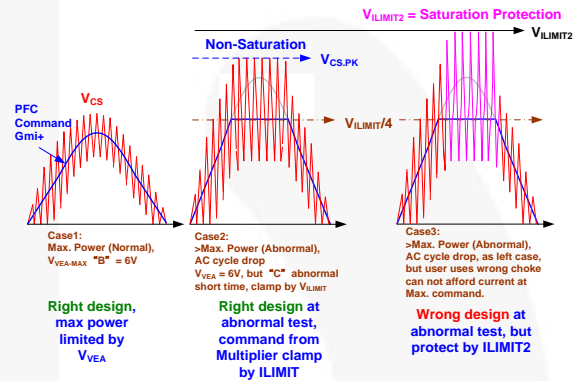

Figure 23. I_{LIMIT} and I_{LIMIT2} Setting

Programmable PFC Output Voltage (PVO)

Decreasing the PFC output voltage can improve efficiency of the PFC stage. The PVO pin is used to modulate output voltage, as Figure 24 shows. This function is controlled by an external voltage signal on PVO pin from MCU or other source.

V_{PVO} should be over 0.5 V and the relationship for V_{PVO} and V_{FBPFC} is given by:

$$V_{FBPFC} = 2.5V - \left[\frac{V_{PVO}}{4} \right] \quad (7)$$

Example: If PVO input is 1 V; R_{FB1}+R_{FB2}= 3.7 MΩ, R_{FB3} = 23.7 kΩ, V_{FBPFB} = 2.25 V, and PFC V_O = 354 V.

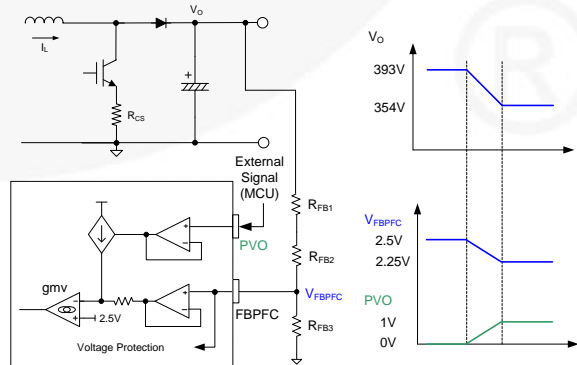

Figure 24. Programmable PFC Output Voltage

RDYF and AC Line Off / AC “Sag”

The ready (RDY) function is used to signal the MCU that the controller is ready and the power stage can start to operate. When the feedback voltage on FBPFC rises to 2.4 V, the V_{RDY} signal pulls HIGH to indicate to the MCU that the next power stage can start, as shown in Figure 25. If the AC line is OFF (or AC signal drops for a long time), the FAN9673 enters brown out and V_{RDY} pulls LOW to indicate to the MCU that the power stage should stop, as shown in Figure 26. When the AC signal drops for only a short time (i.e. 1~1.5 AC cycles) and the IC does not brown out, the FAN9673 recovers the V_{PFC} (same as V_{FBPFC}) when the AC signal is restored to normal, as shown in Figure 27.

AC “sag” means the AC drops to a low level, such as 110 V / 220 V → 40 V. AC “missing” means the AC drops to 0 V. If AC drops, the PFC attempts to transfer energy to V_O before V_O drops to the 50% level. If AC is 0 V, the PFC can’t transfer energy. If the level reaches 50%; the PFC stops, resets, and waits for AC to return.

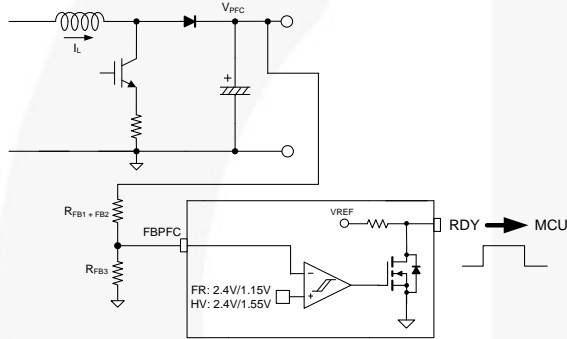

Figure 25. RDY Function to MCU

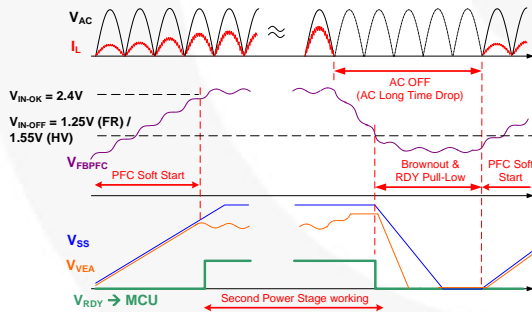

Figure 26. AC Drops for Long Time

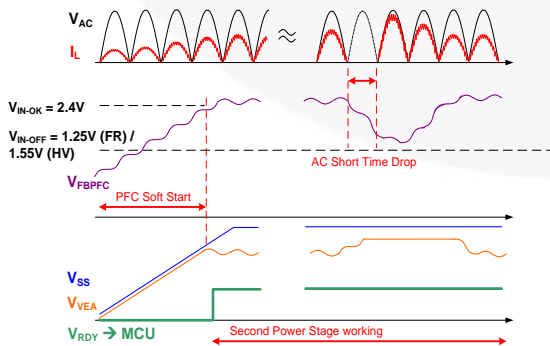

Figure 27. AC Drops Briefly

Soft-Start

Soft-start is combined with RDY pin operation, as Figure 26 and Figure 27 show. During startup, the RDY pin remains LOW until the PFC output voltage reaches 96% of its nominal value. When the supply voltage of the downstream converter is controlled by the RDY pin, the PFC stage starts with no load because the downstream converter does not operate until the PFC output voltage reaches the required level for the design.

Usually, the error amplifier output, V_{EA} , is saturated to HIGH during startup because the actual output voltage is less than the target value. V_{EA} remains saturated to HIGH until the PFC output voltage reaches its target value. Once the PFC output reaches its target value, the error amplifier comes out of saturation. However, it takes several line cycles for V_{EA} to drop to its proper value for output regulation, which delivers more power to the load than required, causing output voltage overshoot. To prevent output voltage overshoot during startup caused by the saturation of error amplifier, the FAN9673 clamps the error amplifier output voltage (V_{EA}) by the V_{SS} value until PFC output reaches 96% of its nominal value.

Input Voltage Peak Detection

The input AC peak voltage is sensed at the IAC pin. The RMS value of input voltage is used for feed-forward control in the gain modulator circuit and output to the LPK pin for MCU use. Since the RMS value of the AC input voltage is directly proportional to its peak, it is sufficient to find the peak instead of the more-complicated and slower method of integrating the input voltage over a half line cycle. The internal circuit of the IAC pin works with peak detection of the input AC waveform, as shown in Figure 28.

One of the important benefits of this approach is that the peak indicates the correct RMS value even at no load. At no load, the HF filter capacitor at the input side of the boost converter is not discharged around the zero-crossing of the line waveform. Another notable benefit is that, during line transients when the peak exceeds the previously measured value, the input-voltage feed-forward circuit can react immediately, without waiting for a valid integral value at the end of the half-line period. Lack of zero-crossing detection can lead to false integrator detection, while peak detection works properly during light-load operation.

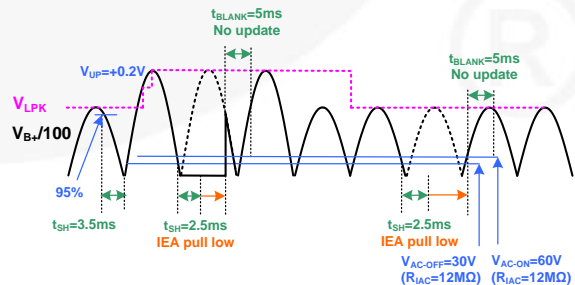

Figure 28. Waveform of LPK Function

The relationship of $V_{IN.PK}$ to V_{LPK} is shown in Figure 29. The peak detection circuit recognizes the V_{IN} information from I_{AC} . R_{LPK} sets the ratio of V_{IN} to V_{LPK} via a resistor R_{RLPK} as described in Equation (8). The target value of V_{LPK} is one percent (1%) of $V_{IN.PK}$. The maximum V_{LPK} cannot exceed 3.8 V when system operation is at maximum AC input.

As in the below design example, assume the maximum $V_{IN.PK}$ at 373 V (264 V_{AC}), the relationship of $V_{IN.PK} / V_{LPK}$ is 100, and $V_{LPK} = 3.73 \text{ V} < 3.8 \text{ V}$.

$$V_{LPK} = \frac{V_{IN.PK}}{100} \times \frac{R_{RLPK}}{12.4k} \quad (8)$$

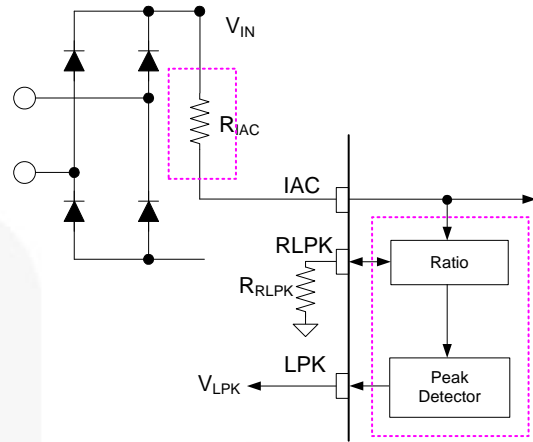

Figure 29. Relationship of $V_{IN.PK}$ to V_{LPK}

Typical Performance Characteristics

Typical characteristics are provided at $T_A = 25^\circ\text{C}$ and $V_{DD} = 15\text{ V}$ unless otherwise noted.

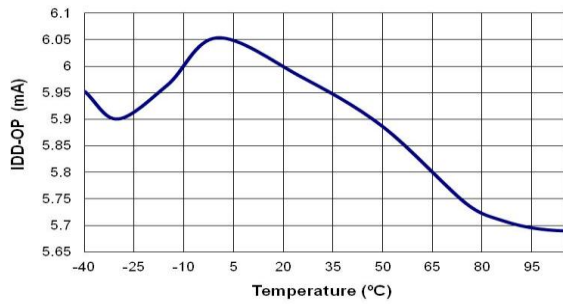

Figure 30. I_{DD-OP} vs. Temperature

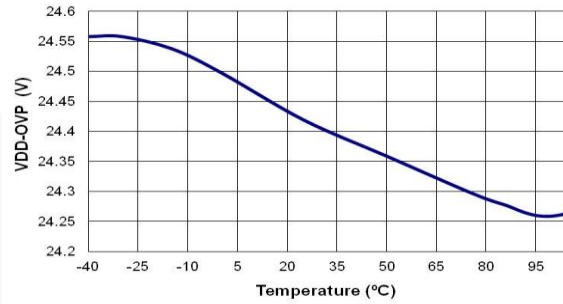

Figure 31. V_{DD-OVP} vs. Temperature

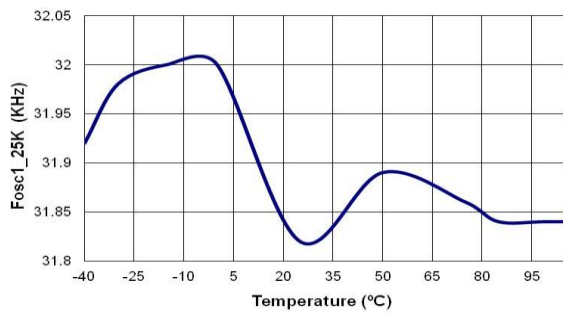

Figure 32. f_{OSC} vs. Temperature

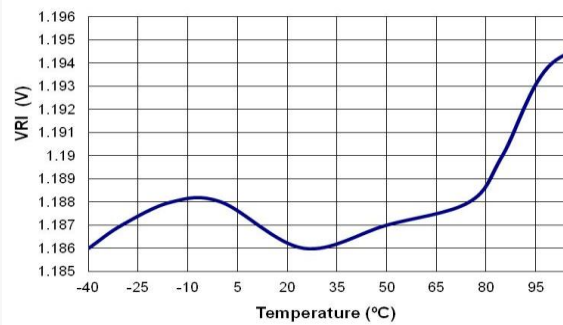

Figure 33. V_{RI} vs. Temperature

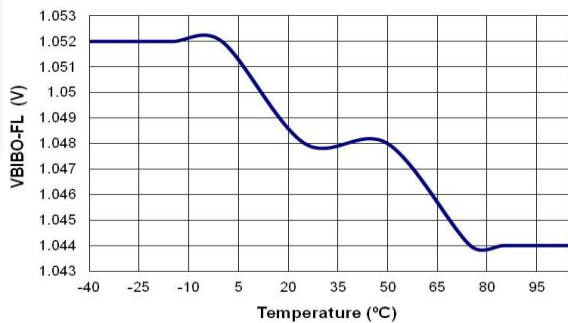

Figure 34. $V_{BIBO-FL}$ vs. Temperature

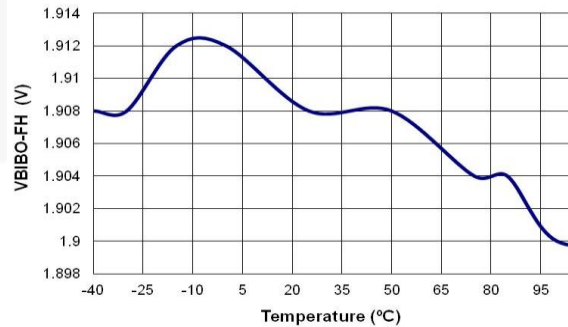

Figure 35. $V_{BIBO-FH}$ vs. Temperature

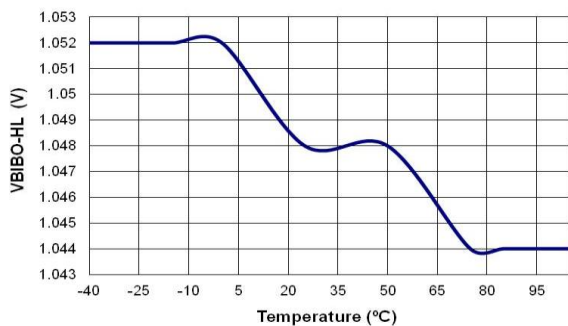

Figure 36. $V_{BIBO-HL}$ vs. Temperature

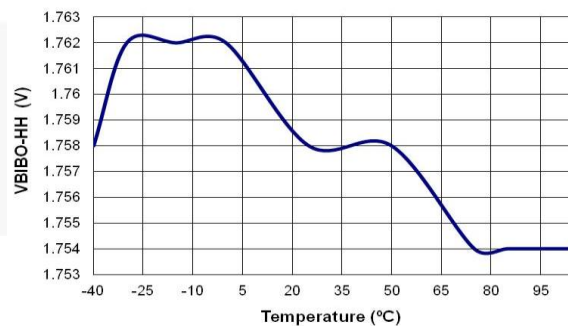

Figure 37. $V_{BIBO-HH}$ vs. Temperature

Typical Performance Characteristics

Typical characteristics are provided at $T_A = 25^\circ\text{C}$ and $V_{DD} = 15\text{ V}$ unless otherwise noted.

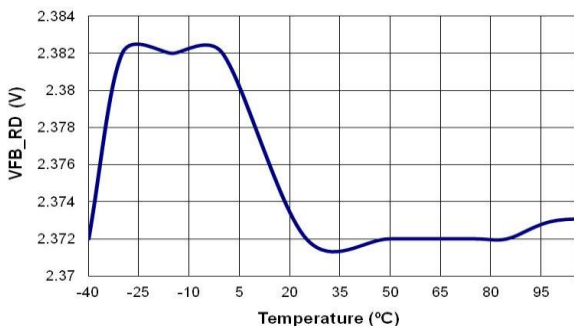

Figure 38. V_{FB_PFC-RD} vs. Temperature

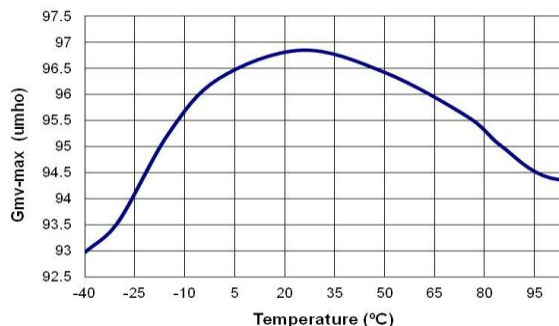

Figure 39. G_{mV-MAX} vs. Temperature

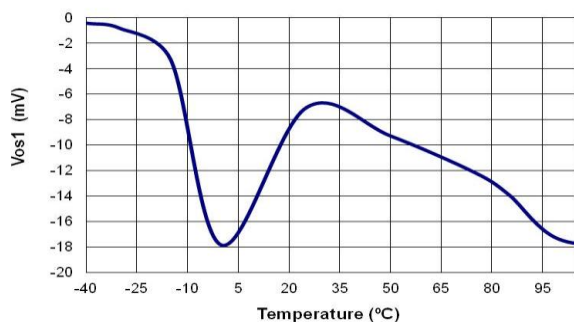

Figure 40. V_{OFFSET} vs. Temperature

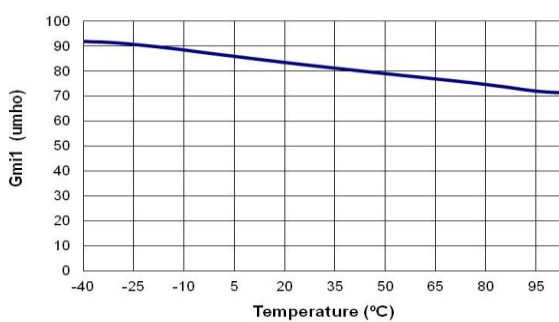

Figure 41. G_{mI} vs. Temperature

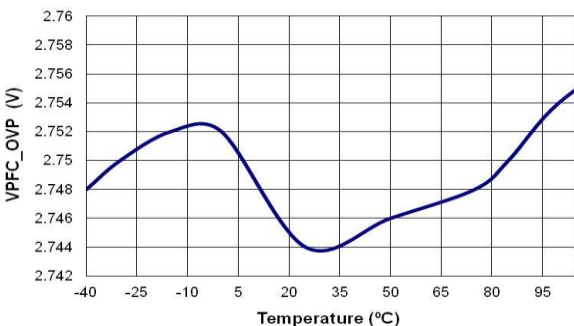

Figure 42. $V_{PFC-OVP}$ vs. Temperature

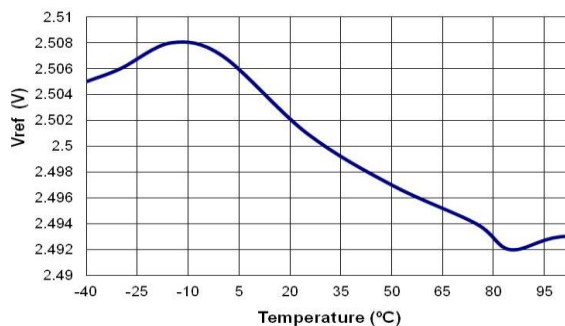

Figure 43. V_{REF} vs. Temperature

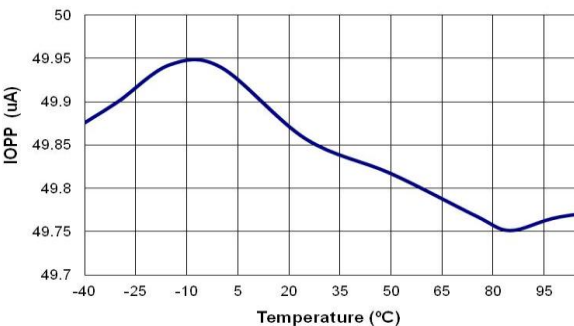

Figure 44. I_{LIMIT} vs. Temperature

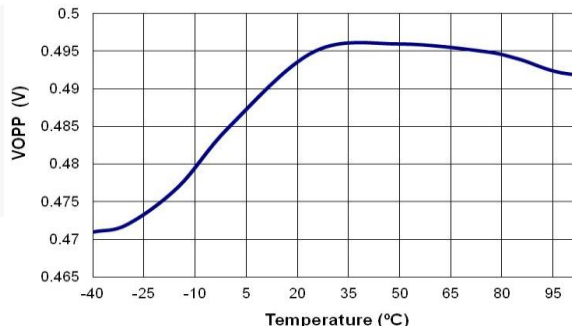

Figure 45. V_{LIMIT} vs. Temperature

Typical Performance Characteristics

Typical characteristics are provided at $T_A = 25^\circ\text{C}$ and $V_{DD} = 15\text{ V}$ unless otherwise noted.

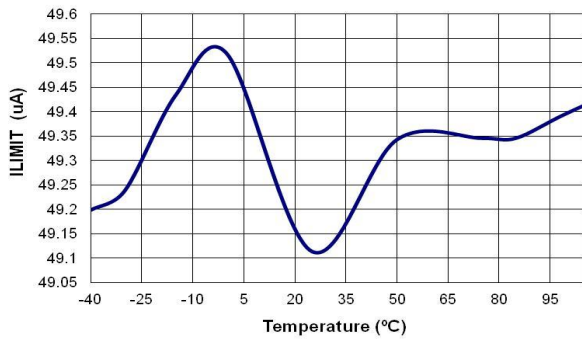

Figure 46. I_{LIMIT2} vs. Temperature

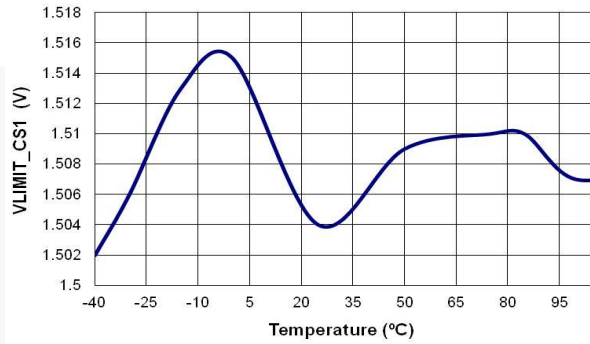

Figure 47. $V_{LIMIT2-CS1}$ vs. Temperature

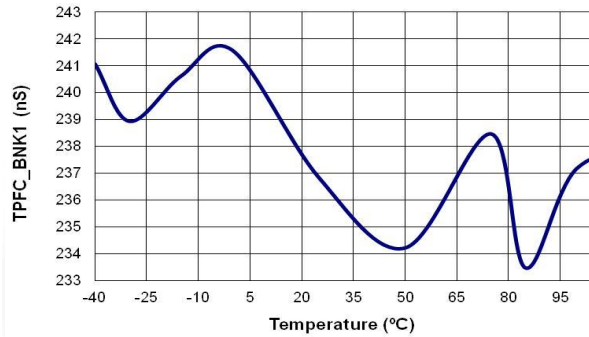

Figure 48. $t_{PFC-BNK}$ vs. Temperature

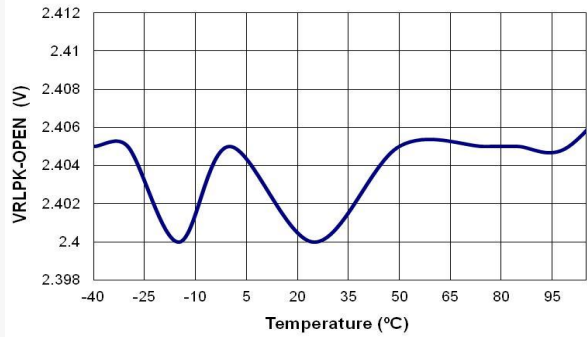

Figure 49. $V_{RLPK-OPEN}$ vs. Temperature

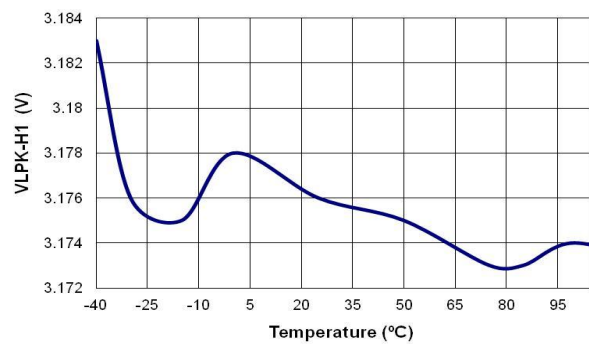

Figure 50. V_{LPK-H1} vs. Temperature

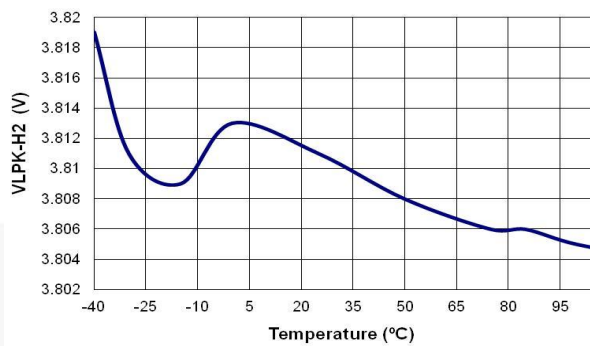

Figure 51. V_{LPK-H2} vs. Temperature

Typical Application Circuit

Application	Output Power	Input Voltage	Output Voltage / Output Current
Single-Stage, Three-Channel PFC	5000 W	180~264 V _{AC}	393 V / 12.72 A

Features

- 180 V_{AC} ~264 V, Three-Channel PFC Using FAN9673
- Switch-Charge Technique of Gain Modulator for Better PF and Lower THD
- 40 kHz Low Switching Frequency Operation with IGBT
- Protections: Over-Voltage Protection (OVP), Under-Voltage Protection (UVP), and Over-Current Protection (I_{LIMIT}), Inductor Saturation Protection (I_{LIMIT2})

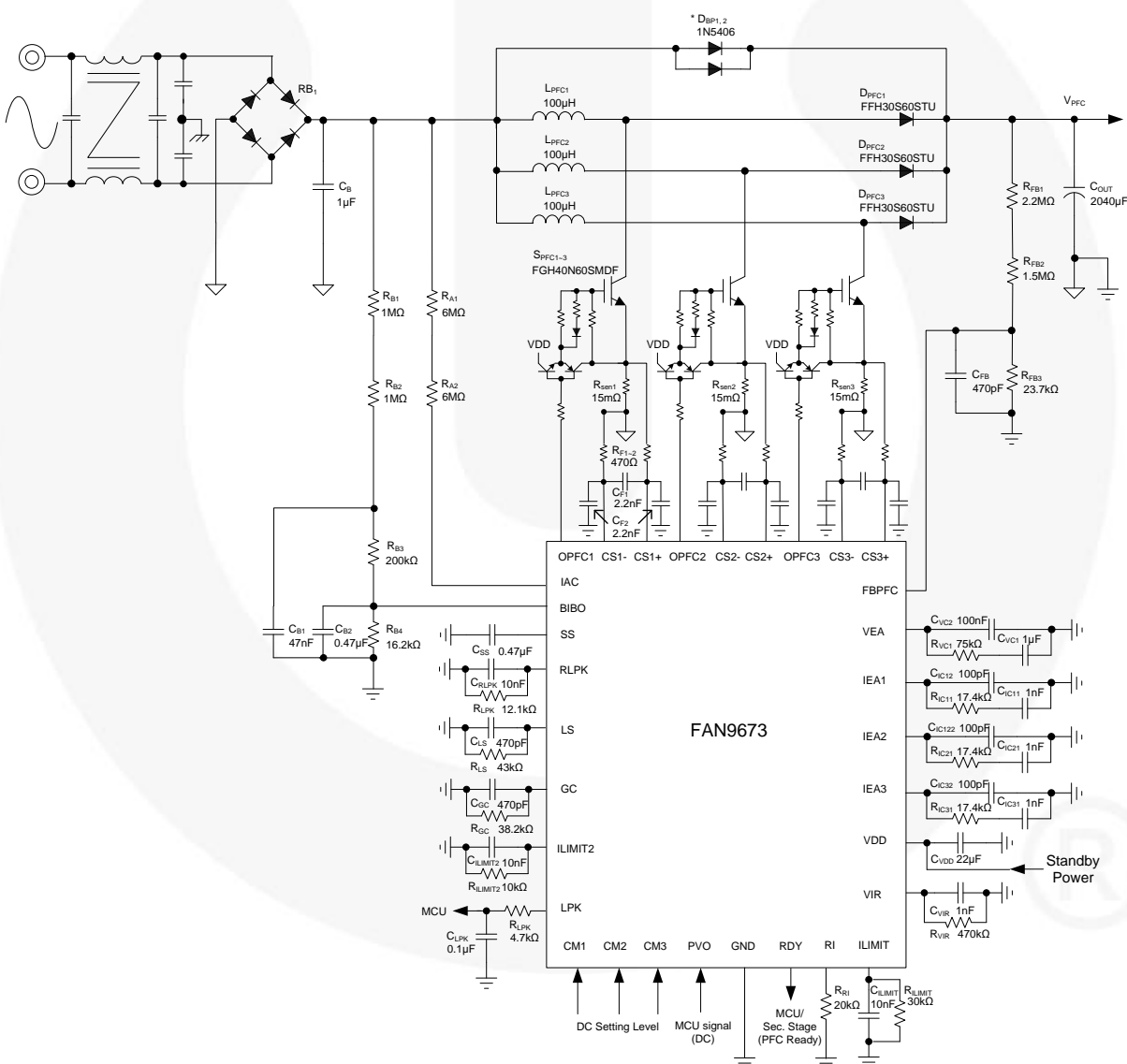

Figure 52. Schematic of Design Example

Specification

- V_{DD} Maximum Rating: 20 V
- V_{DD} OVP: 24 V
- V_{CC} UVLO: 10.3 V / 12.8 V
- PVO: 0 V~1 V
- PFC Soft-Start: $C_{SS} = 0.47 \mu\text{F}$
- Brown-In/Out: 175 V / 165 V
- Switching Frequency: 40 kHz
- Gate Clamp: 2.4 V / 1.55 V (96% / 62%)
- R_{IAC} : 12 M Ω

Inductor Schematic Diagram

- Core: QP2925H (3C94)
- Bobbin: 4 Pins

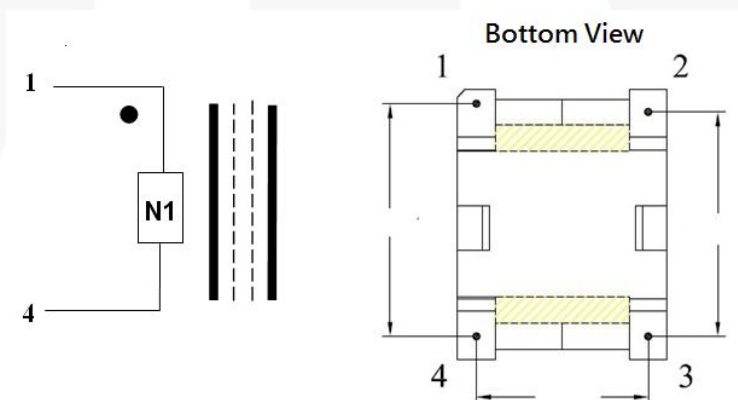

Figure 53. Inductor Schematic Diagram

Table 4. Winding Specification

No.	Winding	Pin (S → F)	Wire	Turns	Winding Method
1	N1	1 → 4	0.1 ϕ ×40 *2	46	Solenoid Winding
2	Insulation: Polyester Tape t = 0.025 mm, 2-Layer				
3	Copper-Foil 1.2T to PIN3				

Table 5. MOSFET and Diode Reference Specification

IGBTs	
Voltage Rating	
600 V (IGBT)	FGH40N60SMDF
Boost Diodes	
600 V	FFH30S60STU

Typical Performance

Table 6. Efficiency

	25% Load	50% Load	75% Load	100% Load
180 V / 50 Hz	96.5%	96.5%	96.5%	96.2%
220 V / 50 Hz	97.0%	97.1%	97.2%	97.1%
264 V / 50 Hz	97.6%	97.9%	97.7%	97.6%

Table 7. Power Factor

	25% Load	50% Load	75% Load	100% Load
180 V / 50 Hz	0.9912	0.9947	0.9971	0.9974
220 V / 50 Hz	0.9800	0.9868	0.9905	0.9924
264 V / 50 Hz	0.9365	0.9369	0.9526	0.9600

Table 8. Total Harmonic Distortion

	25% Load	50% Load	75% Load	100% Load
180 V / 50 Hz	10.55%	9.17%	6.62%	6.40%
220 V / 50 Hz	14.32%	14.36%	12.55%	11.26%
264 V / 50 Hz	25.85%	33.22%	29.59%	27.29%

System Design Precautions

- Pay attention to the inrush current when AC input is first connected to the boost PFC convertor. It is recommended to use NTC and a parallel connected relay circuit to reduce inrush current.
- Add bypass diode to provide a path for inrush current when PFC start up.
- The PFC stage is normally used to provide power to a downstream DC-DC or inverter. It's recommend that downstream power stage is enabled to operate at full load once the PFC output voltage has reaches a level close to the specified steady-state value.
- The PVO function is used to change the output voltage of PFC, V_{PFC} . The V_{PFC} should be kept at least 25 V higher than V_{IN} .

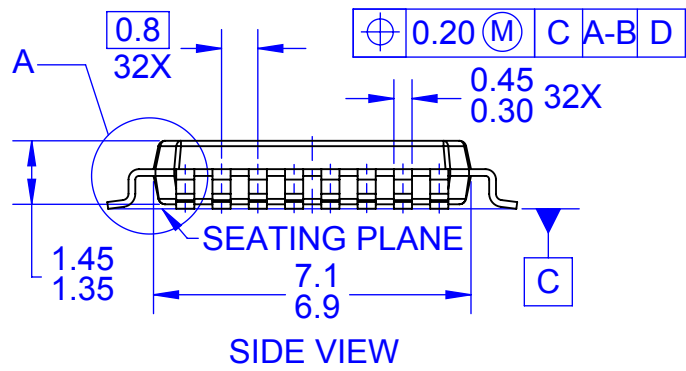
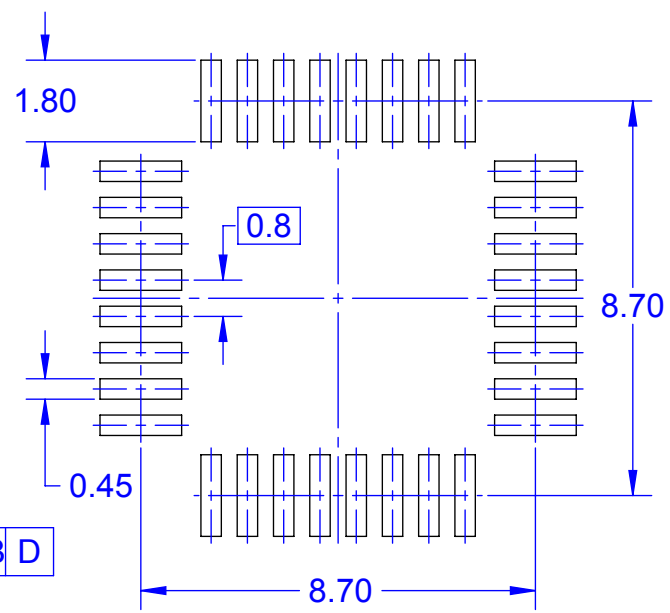
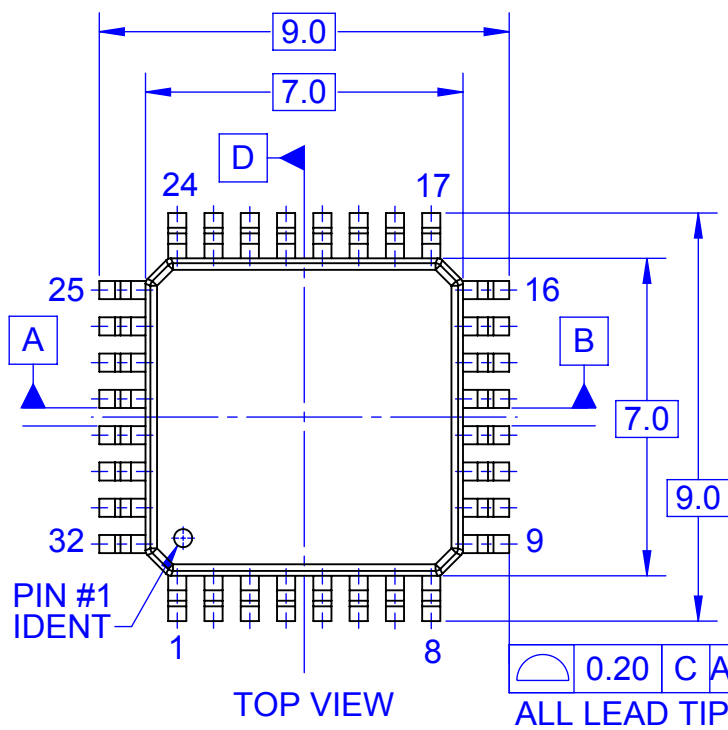

NOTES:

- A. CONFORMS TO JEDEC MS-026 VARIATION BBA
- B. ALL DIMENSIONS ARE IN MILLIMETERS
- C. DIMENSIONING AND TOLERANCING PER ASME Y14.5M-2009
- D. DIMENSIONS EXCLUSIVE OF BURRS, MOLD FLASH, AND TIRE BAR PROTRUSIONS.
- E. LAND PATTERN STANDARD: QFP80P900X900X160-32BM
- F. DRAWING FILENAME: MKT-VBE32Arev3

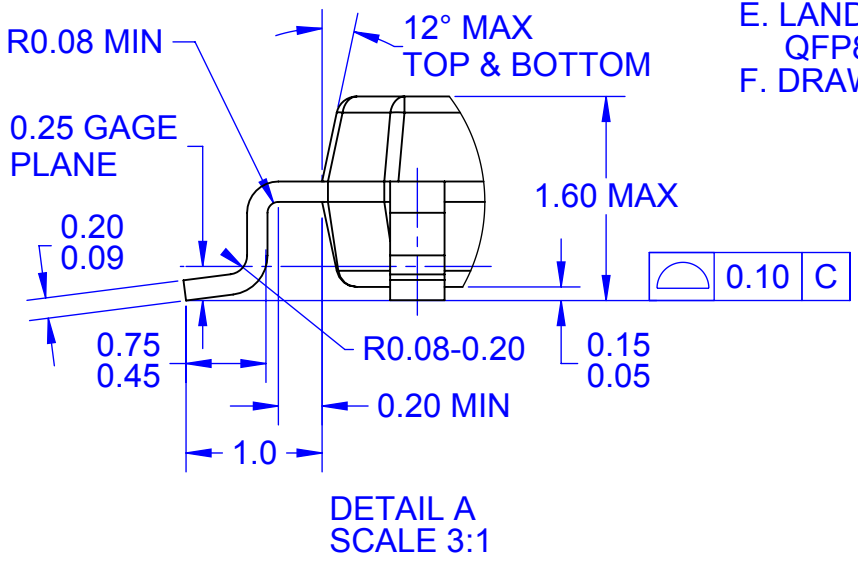

ON Semiconductor and  are trademarks of Semiconductor Components Industries, LLC dba ON Semiconductor or its subsidiaries in the United States and/or other countries. ON Semiconductor owns the rights to a number of patents, trademarks, copyrights, trade secrets, and other intellectual property. A listing of ON Semiconductor's product/patent coverage may be accessed at www.onsemi.com/site/pdf/Patent-Marking.pdf. ON Semiconductor reserves the right to make changes without further notice to any products herein. ON Semiconductor makes no warranty, representation or guarantee regarding the suitability of its products for any particular purpose, nor does ON Semiconductor assume any liability arising out of the application or use of any product or circuit, and specifically disclaims any and all liability, including without limitation special, consequential or incidental damages. Buyer is responsible for its products and applications using ON Semiconductor products, including compliance with all laws, regulations and safety requirements or standards, regardless of any support or applications information provided by ON Semiconductor. "Typical" parameters which may be provided in ON Semiconductor data sheets and/or specifications can and do vary in different applications and actual performance may vary over time. All operating parameters, including "Typicals" must be validated for each customer application by customer's technical experts. ON Semiconductor does not convey any license under its patent rights nor the rights of others. ON Semiconductor products are not designed, intended, or authorized for use as a critical component in life support systems or any FDA Class 3 medical devices or medical devices with a same or similar classification in a foreign jurisdiction or any devices intended for implantation in the human body. Should Buyer purchase or use ON Semiconductor products for any such unintended or unauthorized application, Buyer shall indemnify and hold ON Semiconductor and its officers, employees, subsidiaries, affiliates, and distributors harmless against all claims, costs, damages, and expenses, and reasonable attorney fees arising out of, directly or indirectly, any claim of personal injury or death associated with such unintended or unauthorized use, even if such claim alleges that ON Semiconductor was negligent regarding the design or manufacture of the part. ON Semiconductor is an Equal Opportunity/Affirmative Action Employer. This literature is subject to all applicable copyright laws and is not for resale in any manner.

PUBLICATION ORDERING INFORMATION

LITERATURE FULFILLMENT:

Literature Distribution Center for ON Semiconductor
19521 E. 32nd Pkwy, Aurora, Colorado 80011 USA
Phone: 303-675-2175 or 800-344-3860 Toll Free USA/Canada
Fax: 303-675-2176 or 800-344-3867 Toll Free USA/Canada
Email: orderlit@onsemi.com

N. American Technical Support: 800-282-9855 Toll Free
USA/Canada
Europe, Middle East and Africa Technical Support:
Phone: 421 33 790 2910
Japan Customer Focus Center
Phone: 81-3-5817-1050

ON Semiconductor Website: www.onsemi.com
Order Literature: <http://www.onsemi.com/orderlit>
For additional information, please contact your local
Sales Representative

Mouser Electronics

Authorized Distributor

Click to View Pricing, Inventory, Delivery & Lifecycle Information:

[ON Semiconductor:](#)

[FAN9673Q](#) [FAN9673QX](#)



Стандарт Электрон Связь

Мы молодая и активно развивающаяся компания в области поставок электронных компонентов. Мы поставляем электронные компоненты отечественного и импортного производства напрямую от производителей и с крупнейших складов мира.

Благодаря сотрудничеству с мировыми поставщиками мы осуществляем комплексные и плановые поставки широчайшего спектра электронных компонентов.

Собственная эффективная логистика и склад в обеспечивает надежную поставку продукции в точно указанные сроки по всей России.

Мы осуществляем техническую поддержку нашим клиентам и предпродажную проверку качества продукции. На все поставляемые продукты мы предоставляем гарантию .

Осуществляем поставки продукции под контролем ВП МО РФ на предприятия военно-промышленного комплекса России , а также работаем в рамках 275 ФЗ с открытием отдельных счетов в уполномоченном банке. Система менеджмента качества компании соответствует требованиям ГОСТ ISO 9001.

Минимальные сроки поставки, гибкие цены, неограниченный ассортимент и индивидуальный подход к клиентам являются основой для выстраивания долгосрочного и эффективного сотрудничества с предприятиями радиоэлектронной промышленности, предприятиями ВПК и научно-исследовательскими институтами России.

С нами вы становитесь еще успешнее!

Наши контакты:

Телефон: +7 812 627 14 35

Электронная почта: sales@st-electron.ru

Адрес: 198099, Санкт-Петербург,
Промышленная ул, дом № 19, литера Н,
помещение 100-Н Офис 331