

CLASSIFICATION	PRODUCT SPECIFICATION	No. DS-PAN4580-102	REV. 1.0
SUBJECT	802.15.4-MODEM	PAGE	1 of 34
CUSTOMER'S CODE PAN4580 / PAN4580ETU	PANASONIC'S CODE ENWC9A31xxEF / ENWC9A33xxEF	DATE	19.10.2012

Product Specification

Applicant / Manufacturer
Hardware

Panasonic Industrial Devices Europe GmbH
Zeppelinstrasse 19
21337 Lüneburg
Germany

Applicant / Manufacturer
Software

Please refer to chapter 24 Ordering Information

Software Version

Please refer to chapter 24 Ordering Information

By purchase of any of products described in this document the customer accepts the document's validity and declares their agreement and understanding of its contents and recommendations. Panasonic reserves the right to make changes as required without notification

POWER ELECTRONICS R&D CENTER WIRELESS CONNECTIVITY PANASONIC INDUSTRIAL DEVICES EUROPE GmbH	APPROVED	CHECKED	DESIGNED
--	----------	---------	----------

CLASSIFICATION	PRODUCT SPECIFICATION	No. DS-PAN4580-102	REV. 1.0
SUBJECT	802.15.4-MODEM	PAGE	2 of 34
CUSTOMER'S CODE PAN4580 / PAN4580ETU	PANASONIC'S CODE ENWC9A31xxEF / ENWC9A33xxEF	DATE	19.10.2012

TABLE OF CONTENTS

1.	Key Features.....	4
2.	Applications for the Module.....	4
3.	Description for the Module	4
4.	Scope of this Document.....	5
5.	History for this Document.....	5
6.	Terminal Layout	6
7.	Block Diagram.....	9
8.	Key Parts List.....	9
9.	Test Conditions	9
10.	Absolute Maximum Ratings	10
11.	Operating Conditions	10
12.	Digital Pin Characteristics	10
13.	DC electrical characteristics.....	11
14.	A/D converter Characteristics	12
15.	AC Electrical Characteristics.....	12
	15.1. Transmitter Characteristics.....	12
	15.2. Receiver Characteristics.....	13
16.	Soldering Temperature - Time Profile for reflow soldering.....	14
	16.1. For lead solder.....	14
	16.2. For lead free solder.....	14
17.	Module Dimensions.....	15
	17.1. SMD Module PAN4580 / ENWC9A31xxEF	15
	17.2. Pin header Module PAN4580ETU / ENWC9A33xxEF	15
18.	FootPrint of the Module.....	16
	18.1. SMD Module PAN4580 / ENWC9A31xxEF	16
	18.2. Pin header Module PAN4580ETU / ENWC9A33xxEF	17
19.	Recommended Land Pattern	18
	19.1. SMD Module PAN4580 / ENWC9A31xxEF	18
	19.2. Pin header Module PAN4580ETU / ENWC9A33xxEF	19
20.	Laser/Label marking.....	20
21.	Reliability Tests	21
22.	Cautions	21
	22.1. Design Notes	21
	22.2. Installation Notes	22
	22.3. Usage Conditions Notes	22
	22.4. Storage Notes	22
	22.5. Safety Cautions	23
	22.6. Other cautions	23

CLASSIFICATION	PRODUCT SPECIFICATION	No. DS-PAN4580-102	REV. 1.0
SUBJECT	802.15.4-MODEM	PAGE	3 of 34
CUSTOMER'S CODE PAN4580 / PAN4580ETU	PANASONIC'S CODE ENWC9A31xxEF / ENWC9A33xxEF	DATE	19.10.2012

- 23. Packaging of SMD Module PAN4580 / ENWC9A31xxEF..... 24
 - 23.1. Tape Dimension..... 24
 - 23.2. Packing in Tape 24
 - 23.3. Component direction..... 25
 - 23.4. Reel Dimension 25
 - 23.5. Label for Package..... 26
 - 23.6. Total Packing Handling..... 28
 - 23.7. Cover tape reel strength 28
- 24. Ordering Information 29
- 25. RoHS Declaration 30
- 26. Data Sheet Status 30
- 27. Regulatory Information..... 30
 - 27.1. FCC Notice 30
 - 27.2. Caution 30
 - 27.3. Labeling Requirements..... 31
 - 27.4. Antenna Warning 31
 - 27.5. Approved Antenna List 31
 - 27.6. RF Exposure PAN4580 32
- 28. Industry Canada Certification..... 32
- 29. European R&TTE Declaration of Conformity 32
- 30. Related Documents..... 33
- 31. General Information 33
- 32. Life Support Policy 34

CLASSIFICATION	PRODUCT SPECIFICATION	No. DS-PAN4580-102	REV. 1.0
SUBJECT	802.15.4-MODEM	PAGE	4 of 34
CUSTOMER'S CODE PAN4580 / PAN4580ETU	PANASONIC'S CODE ENWC9A31xxEF / ENWC9A33xxEF	DATE	19.10.2012

1. KEY FEATURES

- Available as small size SMD device (29.8mm x 19.0mm x 2.7mm) or ETU (Easy to use) with pin header (33.9 x 33.9 x 7.3mm)
- 2.4GHz RF Frequency
- 3 antenna options: Single port 50Ω, ceramic antenna or plug
- 16 selectable Channels with up to 2Mbps RF data rate
- Low power modes for increased battery life
- High sensitivity: -99dBm typ. @ 250kbps & 1% Packet Error Rate
- +3.0 dBm @ 2.4GHz P_{out} programmable over a 20 dB range
- Low supply voltage (1.9 V to 3.6 V, 3.0 V typ.)
- Operating temperature range -40°C to +85°C
- 128k total Flash, when using SNAP: 58.5k free for uploadad user SNAPpy scripts.
- 2 UART ports for control or transparent data
- 38 GPIOs and up to 7 A/D inputs with 10 Bit ADC for fast and easy conversion from analog inputs -such as temperature, pressure and fluid levels- to digital values.
- Spread Spectrum (DSSS) technology surmounts noisy environments when using SNAP®
- Low power mode: 1.5µA with internal timer running
- Mesh (SNAP®) Mesh networking Topology with 16 Channels
- Manufactured in conformance with RoHS

2. APPLICATIONS FOR THE MODULE

- Automatic Meter Reading
- Inventory management, Factory- and home automation
- Wireless Sensor Networks, e.g. Lighting Control
- Monitoring (environmental, patient or fitness)

3. DESCRIPTION FOR THE MODULE

The PAN4580 module is a short range, low power, 2.4GHz ISM band transceiver which includes a complete 802.15.4 physical layer (PHY). It is designed for the IEEE 802.15.4 wireless standard. Using an appropriate microcontroller (MCU) with reference oscillator provides a cost effective solution for short range data links and networks.

The PAN4580 and PAN4580ETU comes optionally pre-loaded with the Synapse SNAP® mesh network operating system.

This module is CE and FCC / IC certified.

The PAN4580 use the MCU with integrated Transceiver ATmega128RFA1 from Atmel.

Please contact your local sales office for further details on additional options and services, by visiting www.panasonic.com/rfmodules or write an e-mail to wireless@eu.panasonic.com.

CLASSIFICATION	PRODUCT SPECIFICATION	No. DS-PAN4580-102	REV. 1.0
SUBJECT	802.15.4-MODEM	PAGE	5 of 34
CUSTOMER'S CODE PAN4580 / PAN4580ETU	PANASONIC'S CODE ENWC9A31xxEF / ENWC9A33xxEF	DATE	19.10.2012

4. SCOPE OF THIS DOCUMENT

This product specification applies to Panasonic's 802.15.4 Modem PAN4580 // ENWC9A31xxEF and PAN4580ETU // ENWC9A33xxEF.
Different versions of the PAN4580 are available (refer to chapter 24).

5. HISTORY FOR THIS DOCUMENT

Revision	Date	Modification / Remarks
0.1	20.03.2012	Initial draft version
1.0	19.10.2012	Add ETU-module, add FCC/IC certification

CLASSIFICATION	PRODUCT SPECIFICATION	No. DS-PAN4580-102	REV. 1.0
SUBJECT	802.15.4-MODEM	PAGE	6 of 34
CUSTOMER'S CODE PAN4580 / PAN4580ETU	PANASONIC'S CODE ENWC9A31xxEF / ENWC9A33xxEF	DATE	19.10.2012

6. TERMINAL LAYOUT

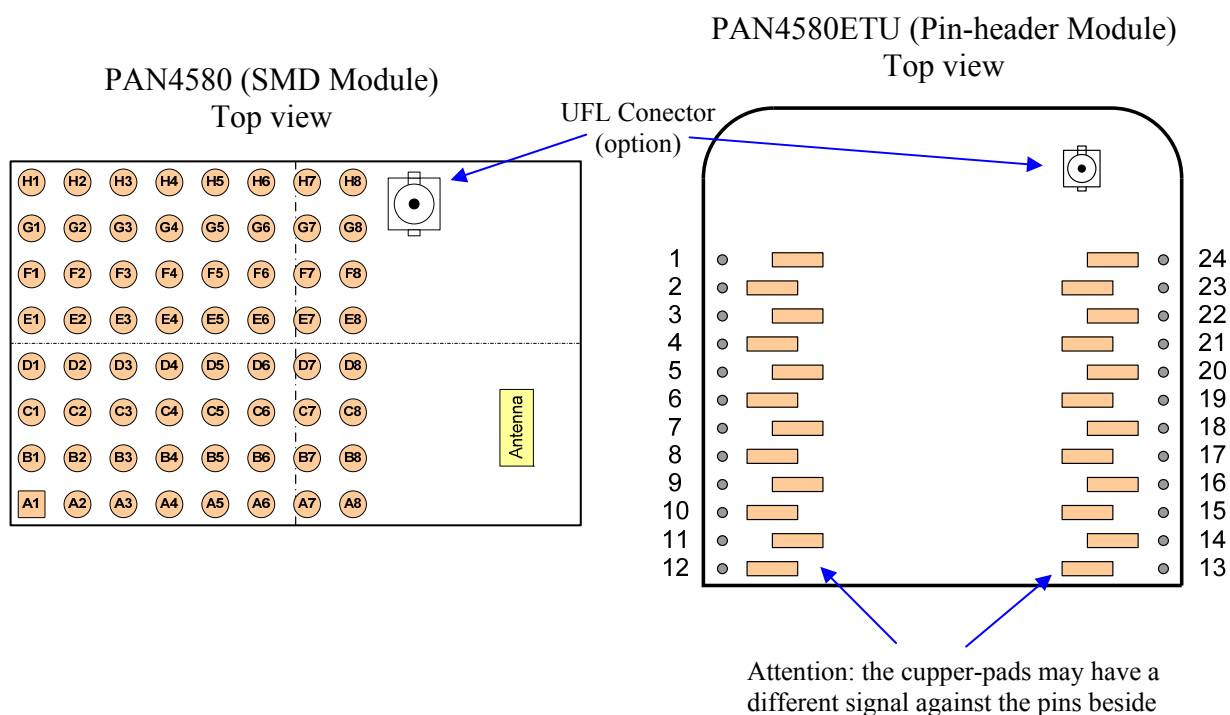

Pin No. PAN4580	Pin No. PAN4580ETU	Pin Name	SNAPpy IO ¹	Description
A1, A8, B8, C8, D8, F8, G8, H1, H8	1, 24	GND		DC Power supply, 0V
A2, A3	21	VDD		DC Power supply, typical 3V (1.8 ~ 3.6V)
A4	13	PF0_ADC0	24	IO or ADC input channel 0
A5	15	PF2_ADC2_DIG2	26	IO or ADC input channel 2 or Radio Transceiver Antenna Diversity Control Output
A6	17	PF4_ADC4_TCK	28	IO or ADC input channel 4 or JTAG Test Clock
A7	19	PF6_ADC6_TDO	30	IO or ADC input channel 6 or JTAG Test Data Output or I ² C SDA
B1	16	PE2_XCK0_AIN0	18	IO or Analog Comparator Positive Input or USART0 external clock input/output
B2	22	PE3_OC3A_AIN1	19	IO or Analog Comparator Negative Input or Output Compare and PWM Output A for Timer/Counter3
B3	8	PE5_OC3C_INT5	21	IO or External Interrupt5 Input or Output Compare and PWM Output C for Timer/Counter3

¹ When using SNAP Software by Synapse Wireless, Inc.

CLASSIFICATION	PRODUCT SPECIFICATION	No. DS-PAN4580-102	REV. 1.0
SUBJECT	802.15.4-MODEM	PAGE	7 of 34
CUSTOMER'S CODE PAN4580 / PAN4580ETU	PANASONIC'S CODE ENWC9A31xxEF / ENWC9A33xxEF	DATE	19.10.2012

Pin No. PAN4580	Pin No. PAN4580ETU	Pin Name	SNAPpy IO ¹	Description
B4	14	PF1_ADC1	25	IO or ADC input channel 1
B5		PG1_DIG1	33	IO or Radio Transceiver Antenna Diversity Control Output
B6	18	PF5_ADC5_TMS	29	IO or ADC input channel 5 or JTAG Test Mode Select
B7	20	PF7_ADC7_TDI	31	IO or ADC input channel 7 or JTAG Test Data Input or I ² C SCL
C1	5	PE0_RXD0_PCINT8	16	IO or USART0 Receive Pin or Pin Change Interrupt8
C2	6	PE1_TXD0	17	IO or USART0 Transmit Pin
C3	7	PE4_OC3B_INT4	20	IO or External Interrupt4 Input or Output Compare and PWM Output B for Timer/Counter3
C4		PE6_T3_INT6	22	IO or External Interrupt6 Input or Timer/Counter3 Clock Input
C5	12	PE7_ICP3_INT7_CLK0	23	IO or UART1 RTS or External Interrupt7 Input, Timer/Counter3 Input Capture Trigger or Divided System Clock
C6		PF3_ADC3_DIG4		IO or ADC input channel 3 or Radio Transceiver RX/TX Indicator Output
D1	4	PB5_OC1A_PCINT5	5	IO or Output Compare and PWM Output A for Timer/Counter1 or Pin Change Interrupt 5
D2	3	PB6_OC1B_PCINT6	6	IO or Output Compare and PWM Output B for Timer/Counter1 or Pin Change Interrupt 6
D3	2	PB7_OC0A_OC1C_PCINT7	7	IO or Output Compare and PWM Output A for Timer/Counter0, Output Compare and PWM Output C for Timer/Counter1 or Pin Change Interrupt 7
E1		PB2_MOSI_PCINT2	2	IO or SPI Bus Master Output/Slave Input , Programming Data Input or Pin Change Interrupt 2
E2		PB3_MISO_PCINT3	3	IO or SPI Bus Master Input/Slave Output, Programming Data Output or Pin Change Interrupt 3
E3		PB4_OC2A_PCINT4	4	IO or Output Compare and PWM Output A for Timer/Counter2 or Pin Change Interrupt 4
E8		RF IN/OUT		Peripheral transmit 50 Ohm RF output / input pin (only ENWC9A31CxEF, other modules NC)
F1		PB0_SSN_PCINT0	0	IO or SPI Slave Select input or Pin Change Interrupt 0
F2		PB1_SCK_PCINT1	1	IO or SPI Bus Serial Clock or Pin Change Interrupt 1
F3		PD1_SDA_INT1	9	IO or External Interrupt1 Input or I ² C

CLASSIFICATION	PRODUCT SPECIFICATION	No. DS-PAN4580-102	REV. 1.0
SUBJECT	802.15.4-MODEM	PAGE	8 of 34
CUSTOMER'S CODE PAN4580 / PAN4580ETU	PANASONIC'S CODE ENWC9A31xxEF / ENWC9A33xxEF	DATE	19.10.2012

Pin No. PAN4580	Pin No. PAN4580ETU	Pin Name	SNAPpy IO ¹	Description
F4		PD0_SCL_INT0	8	IO or External Interrupt0 Input or I ² C
F5		PG0_DIG3		IO or Radio Transceiver RX/TX Indicator Output
F6		PG2_AMR		IO or Automated Meter Reading - Counter Input for Timer/Counter2
G1		CLKI		Must be pulled low during normal operation
G2		PD7_T0	15	IO or Timer/Counter0 Clock Input
G3	11	PD4_ICP1	12	IO or UART1 CTS output or Timer/Counter1 Input Capture Trigger
G4	9	PD2_RXD1_INT2	10	IO or UART1 Receive Pin or External Interrupt2 Input
G5		PG5_OC0B	37	IO or Output Compare and PWM Output B for Timer/Counter0
H2		PD6_T1	14	IO or Timer/Counter1 Clock Input
H3		PD5_XCK1	13	IO or USART1 External Clock Input/Output
H4	10	PD3_TXD1_INT3	11	IO or External Interrupt3 Input or UART1 Transmit Pin
H5	23	RESET#		Module Reset, Active Low
H6		TST		Must be pulled low during normal operation
C7, D4, D5, D6, D7, E4, E5, E6, E7, F7, G6, G7, H7		NC		-

CLASSIFICATION	PRODUCT SPECIFICATION	No. DS-PAN4580-102	REV. 1.0
SUBJECT	802.15.4-MODEM	PAGE	9 of 34
CUSTOMER'S CODE PAN4580 / PAN4580ETU	PANASONIC'S CODE ENWC9A31xxEF / ENWC9A33xxEF	DATE	19.10.2012

7. BLOCK DIAGRAM

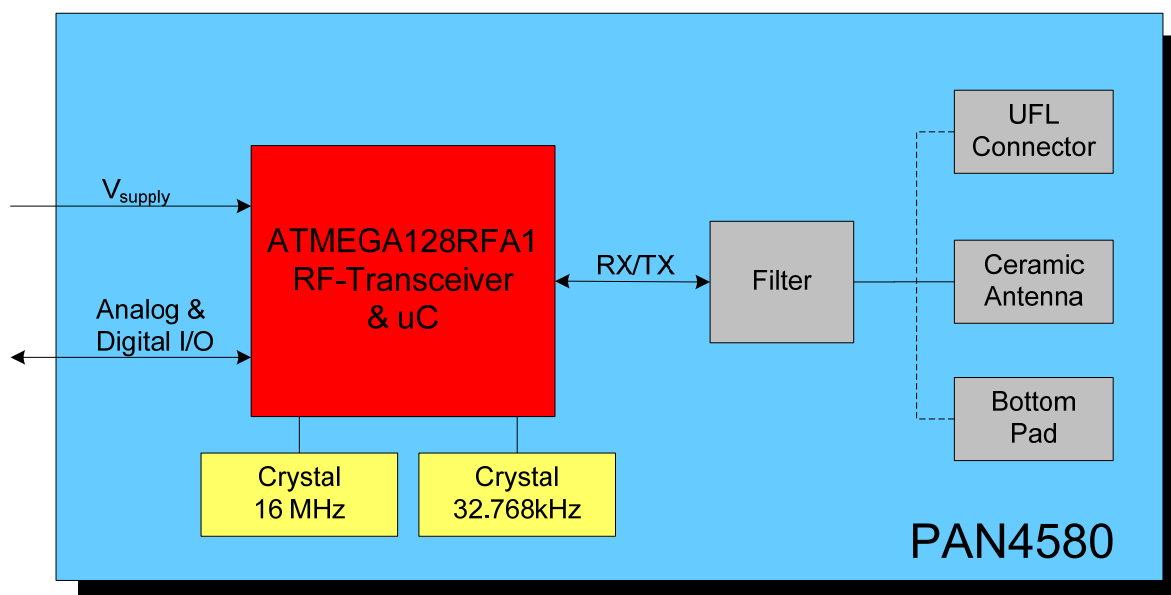

8. KEY PARTS LIST

Part Name	Material
P.W.Board	Glass cloth epoxide resin with gold plating
Casing	Material: C7521, thickness 0.15mm
IC part name	ATmega128RFA1 (Atmel, www.atmel.com)

9. TEST CONDITIONS

Measurements are made under room temperature and humidity unless otherwise specified.

Temperature	25 ± 10°C
Humidity	40 to 85%RH
Supply voltage	3.0V

CLASSIFICATION	PRODUCT SPECIFICATION	No. DS-PAN4580-102	REV. 1.0
SUBJECT	802.15.4-MODEM	PAGE	10 of 34
CUSTOMER'S CODE PAN4580 / PAN4580ETU	PANASONIC'S CODE ENWC9A31xxEF / ENWC9A33xxEF	DATE	19.10.2012

10. ABSOLUTE MAXIMUM RATINGS

The maximum ratings may not be exceeded under any circumstances, not even momentarily and individually, as permanent damage to the module will result.

Symbol	Parameter	Condition	Min.	Typ.	Max.	Units
T _{STOR}	Storage temperature		-40		+85	°C
V _{ESD}	ESD robustness	Human Body Model (HBM)			±2	kV
P _{RF}	Input RF level				+14	dBm
V _{DDMAX}	Maximum voltage	Maximum voltage from any pin to ground	-0.3		3.6	V
V _{DIG}	Voltage on all pins	except pins B3,C4,F3,F4	-0.3		V _{DDMAX}	V
V _{ANA}	Voltage on pins B3,C4,F3,F4		-0.3		2.0	V
V _{COMP_IN}	Comparator input voltage	Pins with Comparator input connected by the analog multiplexer	-0.3		V _{DDMAX}	V
V _{PGA_IN}	PGA input voltage	Pins with PGA input connected by the analog multiplexer	-0.3		V _{DDMAX}	V
V _{ADC_IN}	ADC input voltage	Pins with ADC input connected by the analog multiplexer (PGA bypassed)	-0.3		2.0	V
T _{Death}	Surface Mount Solder Reflow Temperature	Refer to chapter 16				

11. OPERATING CONDITIONS

Symbol	Parameter	Condition	Min.	Typ.	Max.	Units
T _{OP}	Operating temperature range		-40		+85	°C
V _{DD}	Supply voltage	Voltage on pins A2,A3	1.9	3.0	3.6	V
V _{OVRDRV}	Pin Overdrive voltage	Pin Voltage exceeding supply voltage except pin E8			+0.3	V

12. DIGITAL PIN CHARACTERISTICS

Symbol	Parameter	Condition	Min.	Typ.	Max.	Units
V _{IH}	High level input voltage ⁽¹⁾	Except pin RSTN pin H5	0.7V _{DD}			V
V _{IL}	Low level input	Except pin RSTN pin H5			0.3V _{DD}	V

CLASSIFICATION		PRODUCT SPECIFICATION		No. DS-PAN4580-102	REV. 1.0
SUBJECT		802.15.4-MODEM		PAGE	11 of 34
CUSTOMER'S CODE PAN4580 / PAN4580ETU		PANASONIC'S CODE ENWC9A31xxEF / ENWC9A33xxEF		DATE	19.10.2012

Symbol	Parameter	Condition	Min.	Typ.	Max.	Units
	voltage ⁽¹⁾					
V _{IHRSTN}	High level input voltage ⁽¹⁾	Pin H5	0.9V _{DD}			V
V _{ILRSTN}	Low level input voltage ⁽¹⁾	Pin H5			0.1V _{DD}	V
V _{OH}	High level output voltage ⁽¹⁾	I _{OH} = -12mA, V _{DD} = 3.6V I _{OH} = -6mA, V _{DD} = 1.8V Max. drive strength by DPDS0/1	V _{DD} - 0.4			V
V _{OL}	Low level output voltage ⁽¹⁾	I _{OL} = 16mA, V _{DD} = 3.6V I _{OL} = 10mA, V _{DD} = 1.8V Max. drive strength by DPDS0/1			0.4	V
V _{OHMIN}	High level output voltage ⁽¹⁾	I _{OH} = -3mA, V _{DD} = 3.6V I _{OH} = -1.5mA, V _{DD} = 1.8V Min. drive strength by DPDS0/1	V _{DD} - 0.4			V
V _{OLMIN}	Low level output voltage ⁽¹⁾	I _{OL} = 4mA, V _{DD} = 3.6V I _{OL} = 2.5mA, V _{DD} = 1.8V Min. drive strength by DPDS0/1			0.4	V
R _{GPIO}	GPIO pull-up resistor	If pull-up resistor is enabled	120		360	kΩ

Notes:

- (1) The capacitive load should not be larger than 50 pF for all I/Os when using the default driver strength settings. Generally, large capacitance loads increase the overall current consumption.

13. DC ELECTRICAL CHARACTERISTICS

Assume V_{CC} = 3.0V, T_{amb} = 25°C if nothing else stated

Symbol	Parameter	Condition	Min.	Typ.	Max.	Units
I _{TX}	Supply current transmit state ⁽²⁾	PTX = 3.5 dBm		20	27	mA
I _{RX}	Supply current receive state ⁽²⁾	RX_ON state		17	23	mA
I _{SLEEP}	Supply current SLEEP state ⁽²⁾⁽³⁾	SLEEP state		1.5		μA

Notes:

- (2) When using the SNAP-core
(3) For sleep-mode settings refer to the SNAP Reference Manual [3]

CLASSIFICATION	PRODUCT SPECIFICATION	No. DS-PAN4580-102	REV. 1.0
SUBJECT	802.15.4-MODEM	PAGE	12 of 34
CUSTOMER'S CODE PAN4580 / PAN4580ETU	PANASONIC'S CODE ENWC9A31xxEF / ENWC9A33xxEF	DATE	19.10.2012

14. A/D CONVERTER CHARACTERISTICS

Symbol	Parameter	Condition	Min.	Typ.	Max.	Units
$V_{REFH}^{(4)}$	Voltage Reference, High	Programmable	1.5	1.6	1.8	V
V_{INDC}	Analog input voltage	Single Ended	0		1.8	V
		Diferential ⁽⁵⁾	0		3.3	V
R_{AS}	Source impedance at input ⁽⁶⁾				3	k Ω
RES	Conversion Resolution	Single Ended CLKADC \leq 4MHz		10		Bits
		Single Ended CLKADC = 8MHz		8		
DNL	Differential non-linearity	$V_{REFH} = 1.6V$, CLKADC=4MHz	-0.5			LSB
INL	Integral non-linearity	$V_{REFH} = 1.6V$, CLKADC=4MHz		0.8		LSB
E_{ZS}	Zero-scale error			1.5		LSB
E_G	Gain error			1		LSB

(4) V_{REFH} is programmable to three fixed values; 1.5V, 1.6V, and 1.8V. The default is 1.6V

(5) Each differential analogue input may be as high as 3.3V but the differential voltage is still limited

(6) Any analog source with a source impedance greater the 3k Ω will increase the sampling time

15. AC ELECTRICAL CHARACTERISTICS

15.1. TRANSMITTER CHARACTERISTICS

Symbol	Parameter	Condition	Min.	Typ.	Max.	Units
P_{TX}	TX Output power	Maximum configurable TX output power value	0	3	6	dBm
P_{RANGE}	Output power range	16 steps		20		dB
P_{ACC}	Output power tolerance				± 3	dB
P_{HARM}	Harmonics					
	2 nd harmonic 3 rd harmonic				-35 -35	dBm

CLASSIFICATION	PRODUCT SPECIFICATION	No. DS-PAN4580-102	REV. 1.0
SUBJECT	802.15.4-MODEM	PAGE	13 of 34
CUSTOMER'S CODE PAN4580 / PAN4580ETU	PANASONIC'S CODE ENWC9A31xxEF / ENWC9A33xxEF	DATE	19.10.2012

15.2. RECEIVER CHARACTERISTICS

Symbol	Parameter	Condition	Min.	Typ.	Max.	Units
P_{SENS}	Receiver sensitivity	250kb/s, PER \leq 1%		-98		dBm
P_{RXMAX}	Maximum RX input level	PER \leq 1%		10		dBm
P_{ACRN}	Adjacent channel rejection: -5 MHz	PER \leq 1%, PRF = -82 dBm		34		
P_{ACRP}	Adjacent channel rejection: +5 MHz	PER \leq 1%, PRF = -82 dBm		38		
P_{AACRN}	Alternate channel rejection: -10 MHz	PER \leq 1%, PRF = -82 dBm		54		
P_{AACRP}	Alternate channel rejection: +10 MHz	PER \leq 1%, PRF = -82 dBm		54		
P_{SPUR}	Spurious emissions: LO leakage 30 – \leq 1000 MHz >1 – 12.75 GHz			-71		dBm
					-57	dBm
					-47	dBm
$f_{RXTXOFFS}$	TX/RX carrier frequency offset	Sensitivity loss < 2 dB	-300 ⁽⁷⁾		+300	kHz
	RSSI tolerance	Tolerance within gain step			\pm 5	dB
	RSSI dynamic range			81		dB
	RSSI resolution			3		dB
	RSSI sensitivity	Defined as RSSI_BASE_VAL		-90		dBm
	Minimum RSSI value	$P_{RF} \leq$ RSSI_BASE_VAL		0		
	Maximum RSSI value	$P_{RF} >$ RSSI_BASE_VAL + 81 dB		28		

(7) Offset equals \pm 120 ppm

CLASSIFICATION	PRODUCT SPECIFICATION	No. DS-PAN4580-102	REV. 1.0
SUBJECT	802.15.4-MODEM	PAGE	14 of 34
CUSTOMER'S CODE PAN4580 / PAN4580ETU	PANASONIC'S CODE ENWC9A31xxEF / ENWC9A33xxEF	DATE	19.10.2012

16. SOLDERING TEMPERATURE - TIME PROFILE FOR REFLOW SOLDERING
(only SMD Module PAN4580 / ENWC9A31xxEF)

16.1. FOR LEAD SOLDER

Recommended temp. profile for reflow soldering

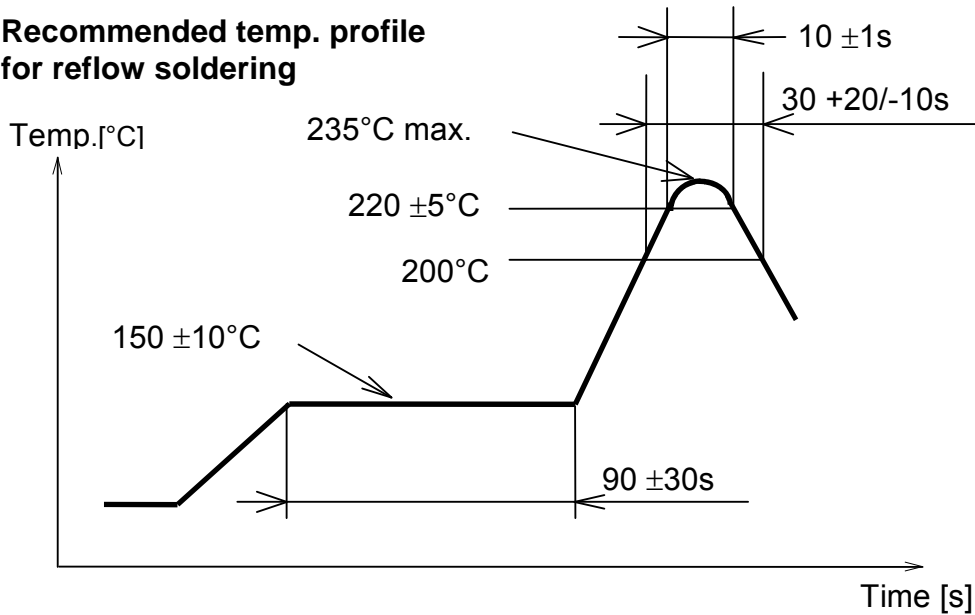

16.2. FOR LEAD FREE SOLDER

Our used temp. profile for reflow soldering

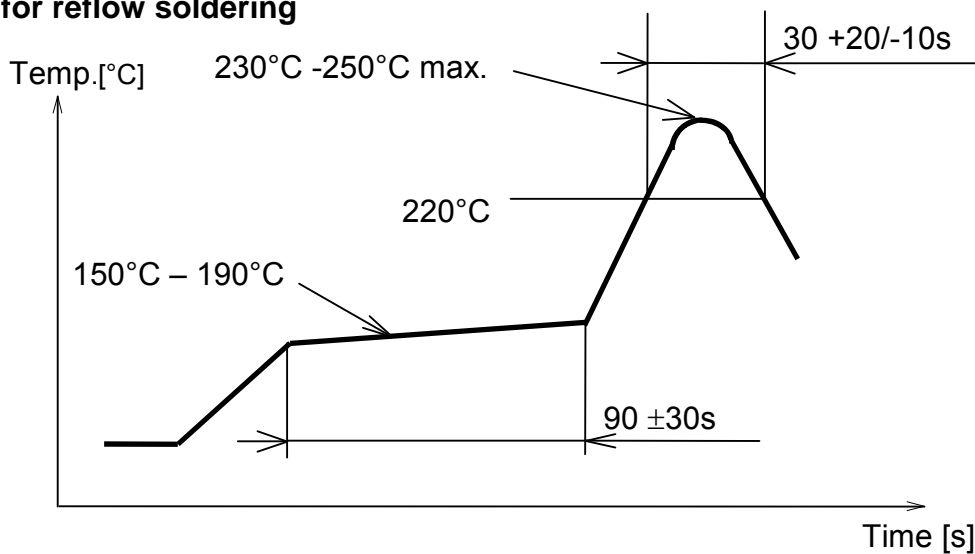

Reflow permissible cycles: 2
Opposite side reflow is prohibited due to the module weight.

CLASSIFICATION	PRODUCT SPECIFICATION	No. DS-PAN4580-102	REV. 1.0
SUBJECT	802.15.4-MODEM	PAGE	15 of 34
CUSTOMER'S CODE PAN4580 / PAN4580ETU	PANASONIC'S CODE ENWC9A31xxEF / ENWC9A33xxEF	DATE	19.10.2012

17. MODULE DIMENSIONS

17.1. SMD MODULE PAN4580 / ENWC9A31XXEF

Item	Dimension	Tolerance	Remark
Width	19.00	± 0.25	
Lenght	29.80	± 0.25	
Height	2.55	± 0.25	With case

17.2. PIN HEADER MODULE PAN4580ETU / ENWC9A33XXEF

Item	Dimension	Tolerance	Remark
Width	33.86	± 0.25	
Lenght	33.86	± 0.25	
Height	7.31	± 0.25	With pin-header

CLASSIFICATION	PRODUCT SPECIFICATION	No. DS-PAN4580-102	REV. 1.0
SUBJECT	802.15.4-MODEM	PAGE	17 of 34
CUSTOMER'S CODE PAN4580 / PAN4580ETU	PANASONIC'S CODE ENWC9A31xxEF / ENWC9A33xxEF	DATE	19.10.2012

18.2. PIN HEADER MODULE PAN4580ETU / ENWC9A33XXEF

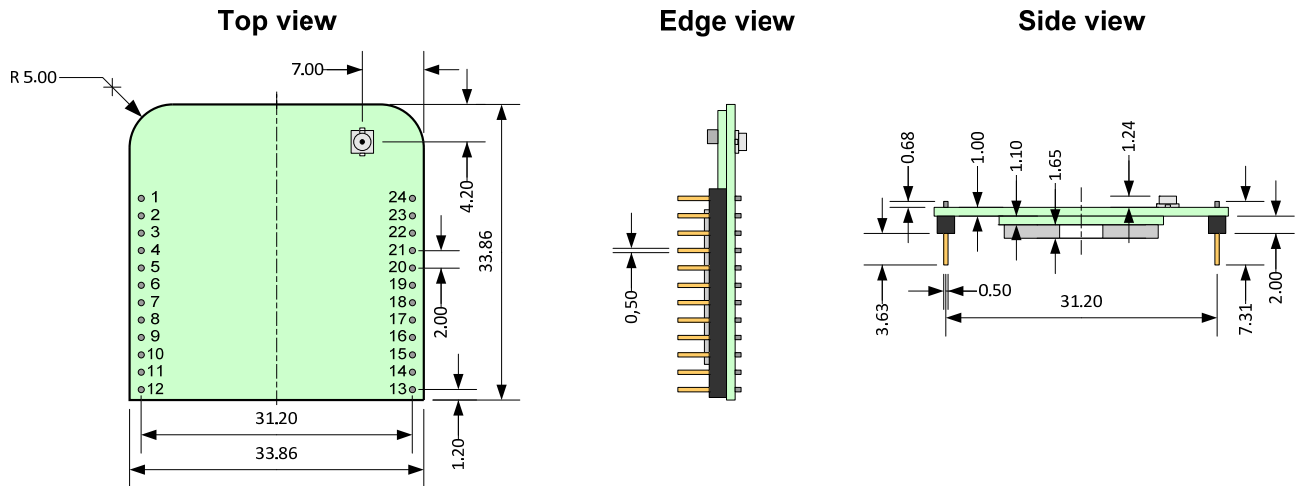

All dimensions are in millimeters.
The outer dimensions have a tolerance of $\pm 0.25\text{mm}$.

CLASSIFICATION	PRODUCT SPECIFICATION	No. DS-PAN4580-102	REV. 1.0
SUBJECT	802.15.4-MODEM	PAGE	18 of 34
CUSTOMER'S CODE PAN4580 / PAN4580ETU	PANASONIC'S CODE ENWC9A31xxEF / ENWC9A33xxEF	DATE	19.10.2012

19. RECOMMENDED LAND PATTERN

19.1. SMD MODULE PAN4580 / ENWC9A31XXEF

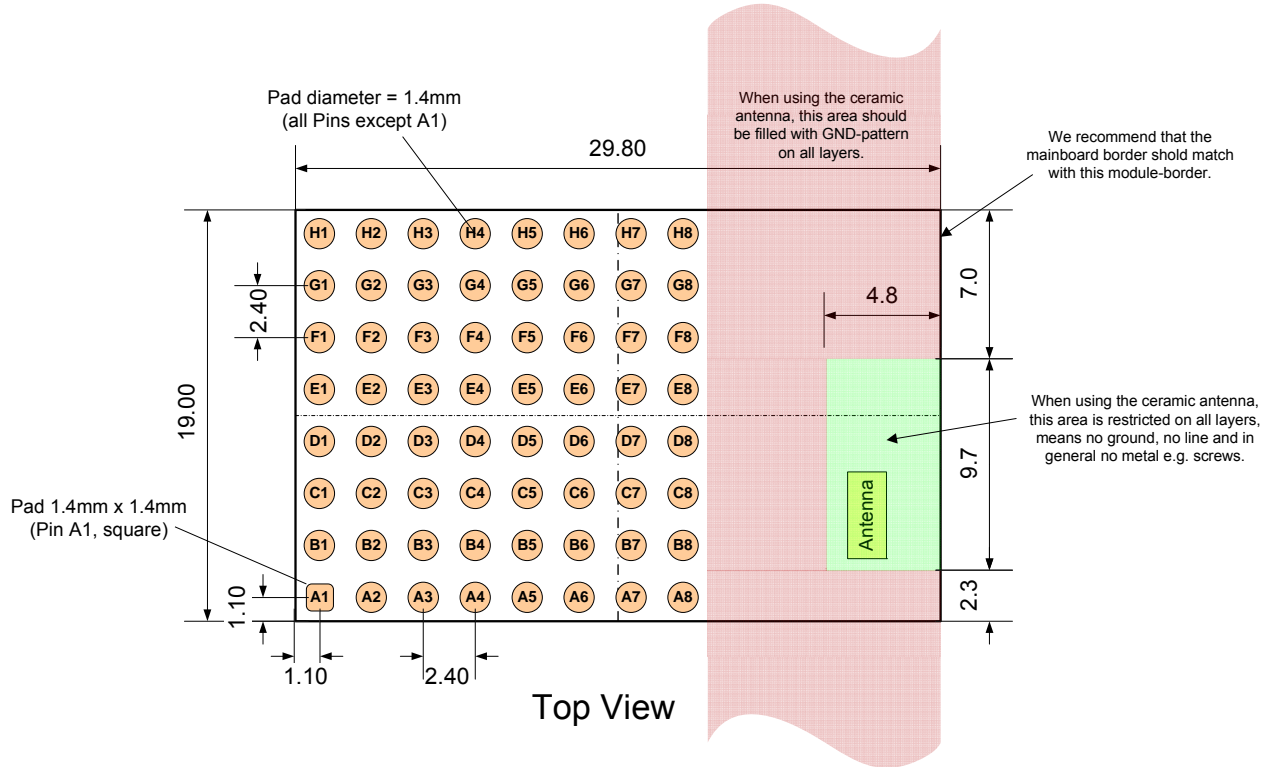

Dimensions in millimeters.

The land pattern dimensions above are meant to serve only as a guid. This information is provided without any legal liability.

It is recommended that the application PCB use the same pad-size as the module footprint.

For the solder paste screen, use as a first guideline the same foot print as shown in the figure above. Solder paste screen cutouts (with slightly different dimensions) might be optimum depending on your soldering process. For example, the solder paste screen thickness chosen might have an effect. The solder screen thickness depends on your production standard - 100µm to 120µm is recommended.

When using a module with an embedded antenna, for optimum RF performance, place the antenna on the edge of your application PCB

If you have any questions on these points, please contact your local Panasonic representative.

Schematics and layouts may be sent to wireless@eu.panasonic.com for final review.

CLASSIFICATION	PRODUCT SPECIFICATION	No. DS-PAN4580-102	REV. 1.0
SUBJECT	802.15.4-MODEM	PAGE	19 of 34
CUSTOMER'S CODE PAN4580 / PAN4580ETU	PANASONIC'S CODE ENWC9A31xxEF / ENWC9A33xxEF	DATE	19.10.2012

19.2. PIN HEADER MODULE PAN4580ETU / ENWC9A33XXEF

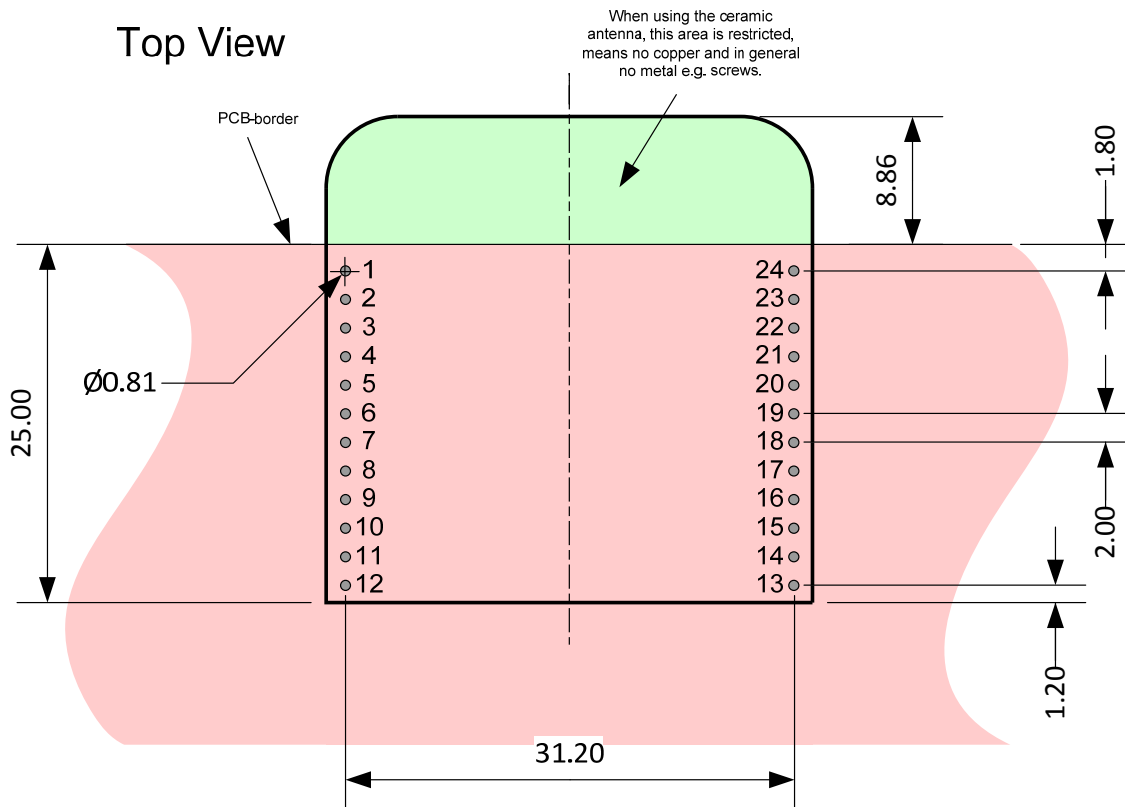

Dimensions in millimeters.

The land pattern dimensions above are meant to serve only as a guid. This information is provided without any legal liability.

When using a module with an embedded antenna, for optimum RF performance, place the antenna on the edge of your application PCB

If you have any questions on these points, please contact your local Panasonic representative.

Schematics and layouts may be sent to wireless@eu.panasonic.com for final review.

CLASSIFICATION	PRODUCT SPECIFICATION	No. DS-PAN4580-102	REV. 1.0
SUBJECT	802.15.4-MODEM	PAGE	20 of 34
CUSTOMER'S CODE PAN4580 / PAN4580ETU	PANASONIC'S CODE ENWC9A31xxEF / ENWC9A33xxEF	DATE	19.10.2012

20. LASER/LABEL MARKING

SMD Module
PAN4580 / ENWC9A31XXEF



Top View

Pin header Module
PAN4580ETU / ENWC9A33xxEF

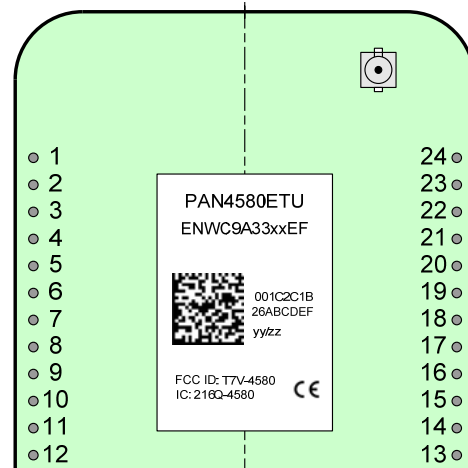

Top View

The 2D-Barcode contains the following information separated by a semicolon:

Value	Description
Date-code	Date code in the format Year - Calender Week - Day of Week – Line - Lot [YYWWDLL]
MAC-adress/ Serial-number	ENWC9A31x5EF (SNAP-software): Last 8 digits of the MAC-adress ENWC9A31x1EF (without software): Sequential serial-number
C9A31xxx (SMD) C9A33xxx (ETU)	Ordering number [8 signs; without the first 3 digits (ENW) and the last digit (F), refer also to chapter 0. Ordering Information]
yyzz	The identifier for the hardware release [2 signs, here yy] and the software release [2 signs, here zz]

The point on the marking (below left) is the identifier for pin 1 of the module.

CLASSIFICATION	PRODUCT SPECIFICATION	No. DS-PAN4580-102	REV. 1.0
SUBJECT	802.15.4-MODEM	PAGE	21 of 34
CUSTOMER'S CODE PAN4580 / PAN4580ETU	PANASONIC'S CODE ENWC9A31xxEF / ENWC9A33xxEF	DATE	19.10.2012

21. RELIABILITY TESTS

Measurements should be completed after the module has been exposed to room temperature and humidity for 1 hour.

No.	Item	Limit	Condition
1	Heat-shock-resistance test	Electrical parameter should be in specification	Temperature: 125°C to -50°C Voltage: off Period: 500cycles Temp. Cycle: -50°C and +125°C each 7min.
2	Humidity load life test	the same as above	Temperature: +85°C Humidity: 85% Period: 500hrs Voltage: on
3	Vibration test	the same as above	Vibration Ampl.: 1.5mm Vibr. Freq.: 10~55~10Hz (total 1min.) Directions: X; Y; Z each 1hrs
4	ESD test	the same as above	Regarding JEDEC JESD-22a114D each contact with 100pF, 1.5kOhm min. 2kV (Human Body Model HBM)
5	MSL test	the same as above	Pre conditioning: Temperature: +85°C Humidity: 85°C Period: 96hrs Soldering condition: Peak: 260°C for ~10s, 2 times

22. CAUTIONS

Failure to do so may result in degrading of the product's functions and damage to the product.

22.1. DESIGN NOTES

- (1) Follow the conditions written in this specification, especially the control signals of this module.
- (2) The supply voltage has to be free of AC ripple voltage (for example from a battery or a low noise regulator output). For noisy supply voltages, provide a decoupling circuit (for example a ferrite in series connection and a blocking capacitor to ground of at least 47uF directly at the module).
- (3) This product should not be mechanically stressed when installed.
- (4) Heat is the major cause of shortening the life of these products. Keep this product away from heat.
Avoid assembly and use of the target equipment in conditions where the products' temperature may exceed the maximum tolerance.
- (5) The supply voltage should not be exceedingly high or reversed. It should not carry noise and/or spikes.
- (6) Keep this product away from other high frequency circuits.

CLASSIFICATION	PRODUCT SPECIFICATION	No. DS-PAN4580-102	REV. 1.0
SUBJECT	802.15.4-MODEM	PAGE	22 of 34
CUSTOMER'S CODE PAN4580 / PAN4580ETU	PANASONIC'S CODE ENWC9A31xxEF / ENWC9A33xxEF	DATE	19.10.2012

22.2. INSTALLATION NOTES

- (1) Reflow soldering is possible twice based on the conditions in chapter 16. Set up the temperature at the soldering portion of this product according to this reflow profile.
- (2) Carefully position the products so that their heat will not burn into printed circuit boards or affect the other components that are susceptible to heat.
- (3) Carefully locate these products so that their temperatures will not increase due to the effects of heat generated by neighboring components.
- (4) If a vinyl-covered wire comes into contact with the products, then the cover will melt and generate toxic gas, damaging the insulation. Never allow contact between the cover and these products to occur.
- (5) This product should not be mechanically stressed or vibrated when reflowed.
- (6) (6) If you want to repair your board by hand soldering, follow the conditions detailed in this chapter.
- (7) Do not wash this product.
- (8) Refer to the recommended pattern when designing a board.
- (9) Pressing parts on the metal cover or fastening objects to the cover will cause damage to the module.

22.3. USAGE CONDITIONS NOTES

- (1) Take measures to protect the unit against static electricity. If pulses or other transient loads (a large load applied in a short time) are applied to the products, check and evaluate their operation before assembly on the final products.
- (2) Do not use dropped products.
- (3) Do not touch, damage or place dirt on the pins.
- (4) Follow the recommended condition ratings about the power supply applied to this product.
- (5) Electrode peeling strength: Do not add pressure of more than 4.9N when soldered on PCB.
- (6) Pressing on parts of the metal cover or fastening objects to the metal cover will cause damage.
- (7) These products are intended for general purpose and standard use in general electronic equipment, such as home appliances, office equipment, information and communication equipment.

22.4. STORAGE NOTES

- (1) The module may not be stressed mechanically during storage.
- (2) Do not store these products in the following conditions or the performance characteristics of the product, such as RF performance will be adversely affected:
 - (3) Storage in salty air or in an environment with a high concentration of corrosive gas, such as Cl₂, H₂S, NH₃, SO₂, or NO_x
 - (4) Storage in direct sunlight
 - (5) Storage in an environment where the temperature may be outside the range of 5°C to 35°C range, or where the humidity may be outside the 45 to 85% range.
 - (6) Storage of the products for more than one year after the date of delivery at your

CLASSIFICATION	PRODUCT SPECIFICATION	No. DS-PAN4580-102	REV. 1.0
SUBJECT	802.15.4-MODEM	PAGE	23 of 34
CUSTOMER'S CODE PAN4580 / PAN4580ETU	PANASONIC'S CODE ENWC9A31xxEF / ENWC9A33xxEF	DATE	19.10.2012

- company if the avoidance all the above conditions (1) to (3) have been met.
- (7) Storage period: Check the adhesive strength of the embossed tape and soldering after 6 months of storage.
 - (8) Keep this product away from water, poisonous gas and corrosive gas.
 - (9) This product should not be stressed or shocked when transported.
 - (10) Follow the specification when stacking packed crates (max. 10).

22.5. SAFETY CAUTIONS

These specifications are intended to preserve the quality assurance of products and individual components.

Before use, check and evaluate the operation when mounted on your products. Abide by these specifications, without deviation when using the products. These products may short-circuit. If electrical shocks, smoke, fire, and/or accidents involving human life are anticipated when a short circuit occurs, then provide the following failsafe functions, as a minimum.

- (1) Ensure the safety of the whole system by installing a protection circuit and a protection device.
- (2) Ensure the safety of the whole system by installing a redundant circuit or another system to prevent a single fault causing an unsafe status.

22.6. OTHER CAUTIONS

- (1) This specification sheet is copyrighted. Do not disclose it to a third party.
- (2) Do not use the products for other purposes than those listed.
- (3) Be sure to provide an appropriate fail-safe function on your product to prevent an additional damage that may be caused by the abnormal function or the failure of the product.
- (4) This product has not been manufactured with any ozone chemical controlled under the Montreal Protocol.
- (5) These products are not intended for other uses, other than under the special conditions shown below. Before using these products under such special conditions, check their performance and reliability under the said special conditions carefully to determine whether or not they can be used in such a manner.
- (6) In liquid, such as water, salt water, oil, alkali, or organic solvent, or in places where liquid may splash.
- (7) In direct sunlight, outdoors, or in a dusty environment
- (8) In an environment where condensation occurs.
- (9) In an environment with a high concentration of harmful gas (e.g. salty air, HCl, Cl₂, SO₂, H₂S, NH₃, and NO_x)
- (10) If an abnormal voltage is applied due to a problem occurring in other components or circuits, replace these products with new products because they may not be able to provide normal performance even if their electronic characteristics and appearances appear satisfactory.
- (11) When you have any question or uncertainty, both of you and Panasonic sincerely cope with it.

CLASSIFICATION	PRODUCT SPECIFICATION	No. DS-PAN4580-102	REV. 1.0
SUBJECT	802.15.4-MODEM	PAGE	24 of 34
CUSTOMER'S CODE PAN4580 / PAN4580ETU	PANASONIC'S CODE ENWC9A31xxEF / ENWC9A33xxEF	DATE	19.10.2012

23. PACKAGING OF SMD MODULE PAN4580 / ENWC9A31XXEF

23.1. TAPE DIMENSION

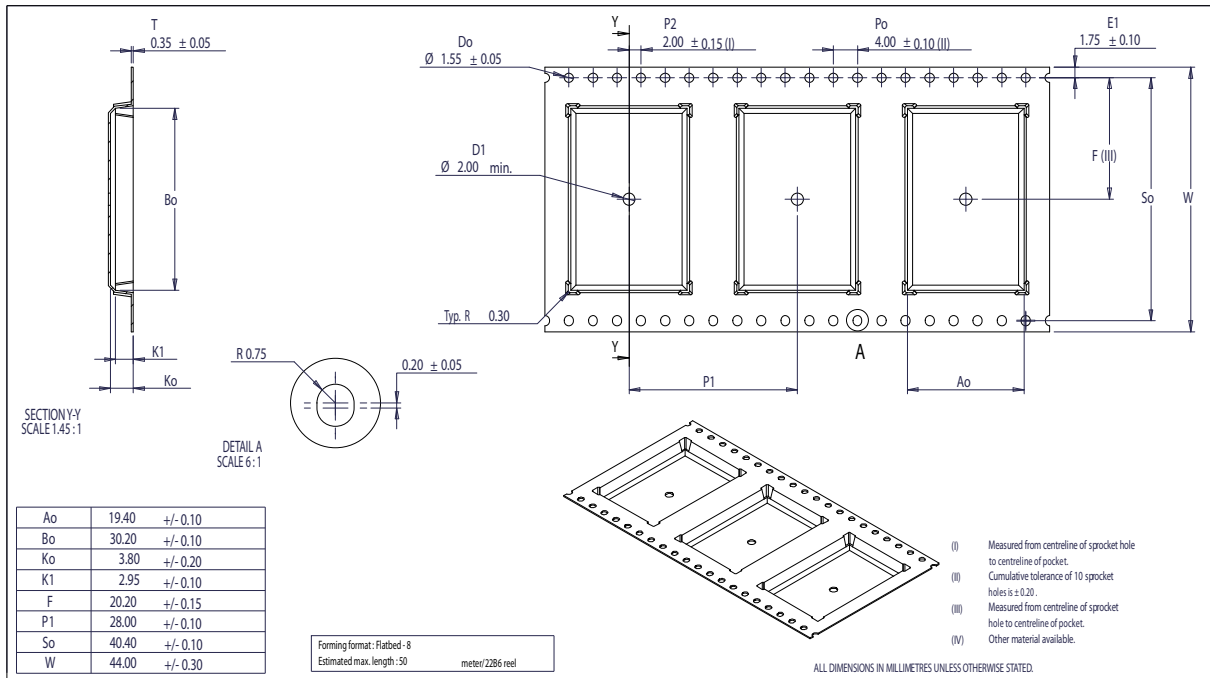

23.2. PACKING IN TAPE

Direction of unreeling (for customer) →

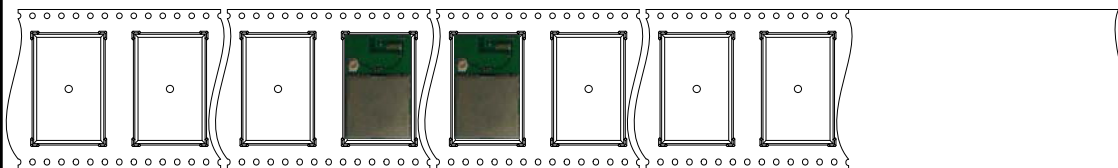

trailer (empty)
1 x circumference / hub
(min 160mm)

component
packed area
standard
500pcs

leader (empty)
minimum 10 pitch

Top cover tape more
than 1 x circumference
plus 100mm to avoid
fixing of tape end on
sealed modules.

Empty spaces in component packed area shall be less than two per reel and those spaces shall not be consecutive.

Top cover tape shall not be found on reel holes and shall not stick out from reel.

CLASSIFICATION	PRODUCT SPECIFICATION	No. DS-PAN4580-102	REV. 1.0
SUBJECT	802.15.4-MODEM	PAGE	25 of 34
CUSTOMER'S CODE PAN4580 / PAN4580ETU	PANASONIC'S CODE ENWC9A31xxEF / ENWC9A33xxEF	DATE	19.10.2012

23.3. COMPONENT DIRECTION

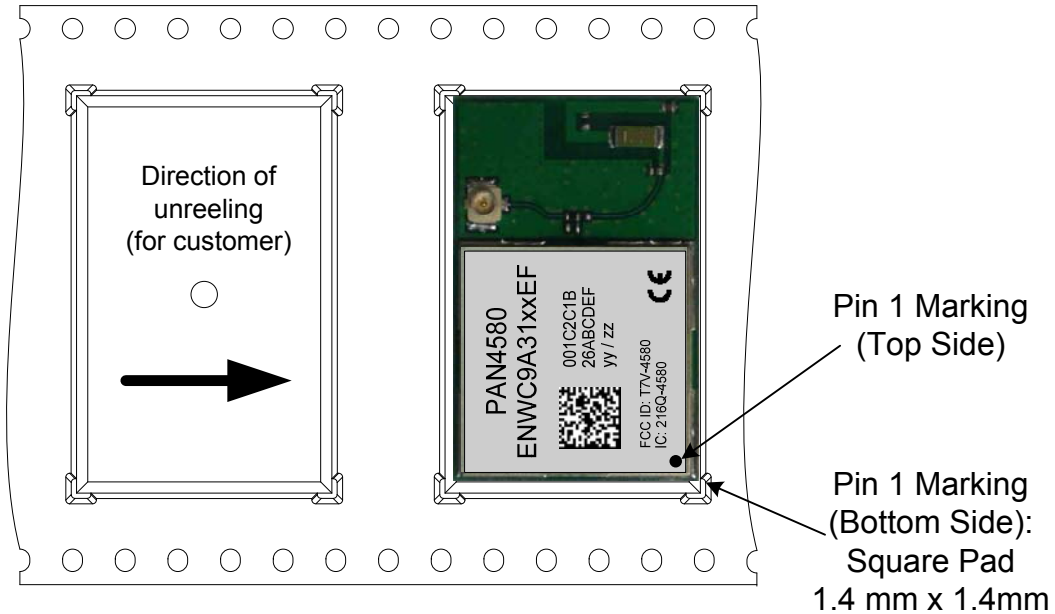

Refer also to chapter 20. Laser/Label marking

23.4. REEL DIMENSION

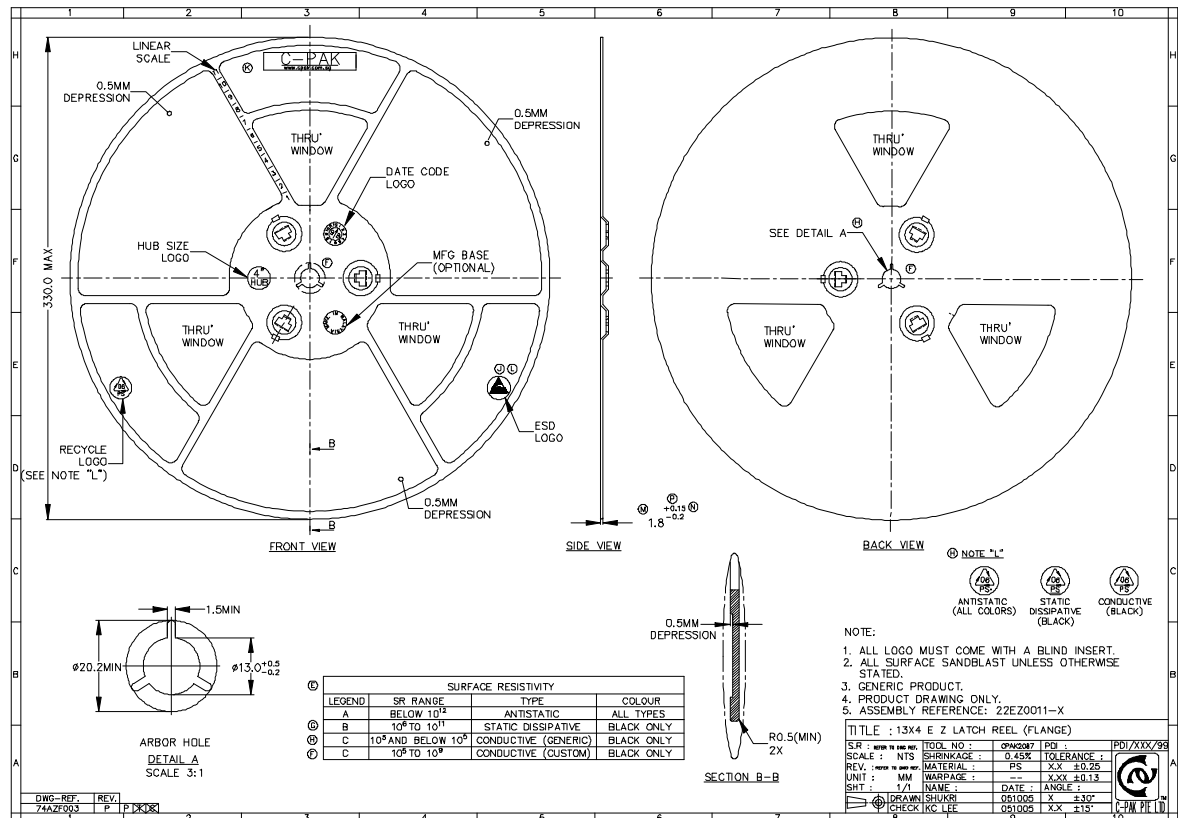

CLASSIFICATION	PRODUCT SPECIFICATION	No. DS-PAN4580-102	REV. 1.0
SUBJECT	802.15.4-MODEM	PAGE	26 of 34
CUSTOMER'S CODE PAN4580 / PAN4580ETU	PANASONIC'S CODE ENWC9A31xxEF / ENWC9A33xxEF	DATE	19.10.2012

23.5.LABEL FOR PACKAGE

The label below shows only an example.

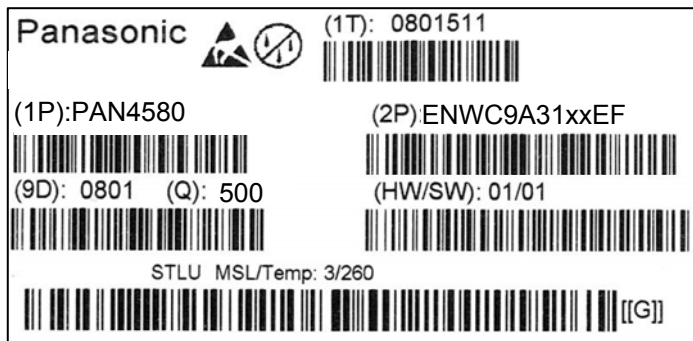

(1T):	Lotcode [YYWWDLL]	
	YY year	above 08
	WW normal calendar week	above 01
	D day	above 5 (Friday)
	L line identifier, if more as one	actual 1
	L lot identifier per day	e.g. 1, 2, 3

(1P) Customers Order Code.

(2P) Panasonic Part Number, refer to chapter 0

CLASSIFICATION	PRODUCT SPECIFICATION	No. DS-PAN4580-102	REV. 1.0
SUBJECT	802.15.4-MODEM	PAGE	27 of 34
CUSTOMER'S CODE PAN4580 / PAN4580ETU	PANASONIC'S CODE ENWC9A31xxEF / ENWC9A33xxEF	DATE	19.10.2012

Ordering Information

(9D) Datecode as [2xYear, 2xMonth, 2xDay]
(Q) Quantity [XXXX], variable
(HW/SW) Hardware /Software Release identifier
[[G]] Identifier that the product is RoHS conform, refer to chapter 25.

CLASSIFICATION	PRODUCT SPECIFICATION	No. DS-PAN4580-102	REV. 1.0
SUBJECT	802.15.4-MODEM	PAGE	28 of 34
CUSTOMER'S CODE PAN4580 / PAN4580ETU	PANASONIC'S CODE ENWC9A31xxEF / ENWC9A33xxEF	DATE	19.10.2012

23.6. TOTAL PACKING HANDLING

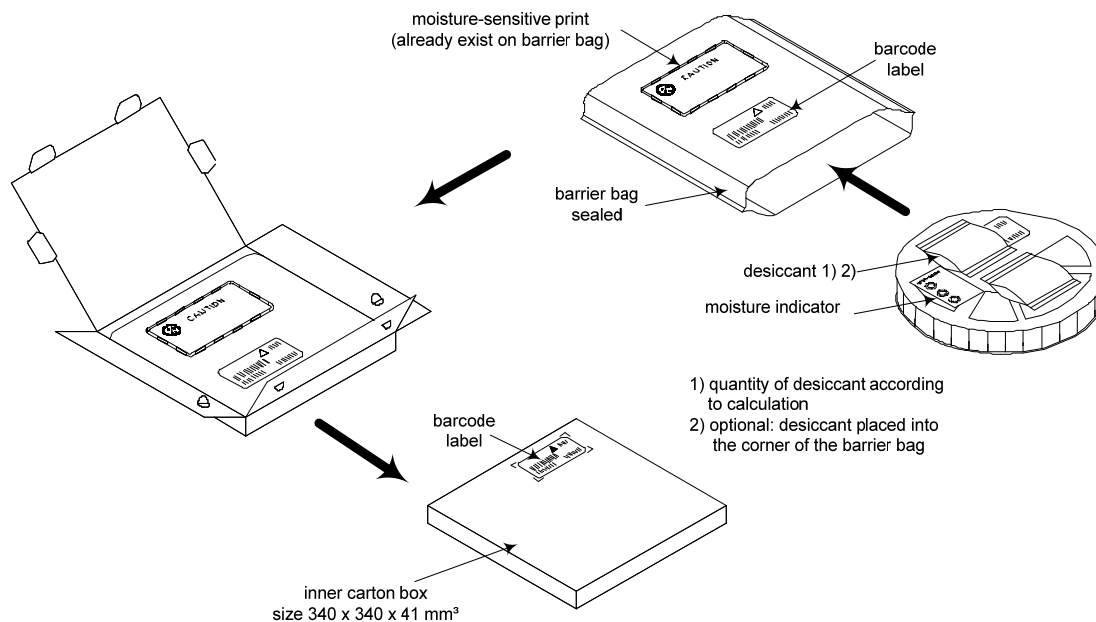

23.7. COVER TAPE REEL STRENGTH

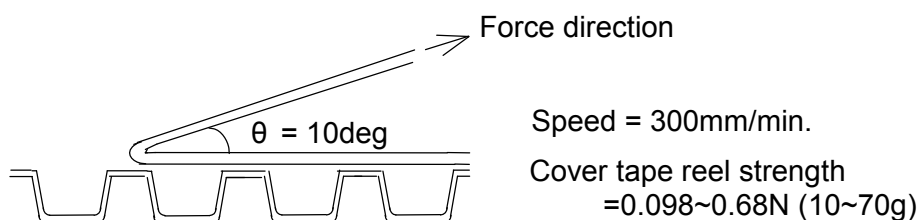

CLASSIFICATION	PRODUCT SPECIFICATION	No. DS-PAN4580-102	REV. 1.0
SUBJECT	802.15.4-MODEM	PAGE	29 of 34
CUSTOMER'S CODE PAN4580 / PAN4580ETU	PANASONIC'S CODE ENWC9A31xxEF / ENWC9A33xxEF	DATE	19.10.2012

24. ORDERING INFORMATION

No.	Ordering part number	Description
1	ENWC9A31A1EF	PAN4580 – 2.4GHz 802.15.4 Mesh Network SMD-Module, which includes <i>Ceramic Antenna</i> and 128kbyte Flash Memory. No software included.
2	ENWC9A31B1EF	PAN4580 – 2.4GHz 802.15.4 Mesh Network SMD-Module, which includes <i>UFL connector</i> and 128kbyte Flash Memory. No software included.
3	ENWC9A31C1EF	PAN4580 – 2.4GHz 802.15.4 Mesh Network SMD-Module, with <i>RF out on SMD pad</i> and 128kbyte Flash Memory. No software included.
4	ENWC9A31A5EF	PAN4580 – 2.4GHz 802.15.4 Mesh Network SMD-Module, which includes <i>Ceramic Antenna</i> and 128kbyte Flash Memory, with 69.5kbyte used by SNAP core, 58.5kbyte free for uploadable SNAPpy scripts. <i>Synapse SNAP software</i> included, refer also to [3].
5	ENWC9A31B5EF	PAN4580 – 2.4GHz 802.15.4 Mesh Network SMD-Module, which includes <i>UFL connector</i> and 128kbyte Flash Memory, with 69.5kbyte used by SNAP core, 58.5kbyte free for uploadable SNAPpy scripts. <i>Synapse SNAP software</i> included, refer also to [3].
6	ENWC9A31C5EF	PAN4580 – 2.4GHz 802.15.4 Mesh Network SMD-Module, with <i>RF out on SMD pad</i> and 128kbyte Flash Memory, with 69.5kbyte used by SNAP core, 58.5kbyte free for uploadable SNAPpy scripts. <i>Synapse SNAP software</i> included, refer also to [3].
7	ENWC9A33A1EF	PAN4580ETU – 2.4GHz 802.15.4 Mesh Network Pin-Header-Module, which includes <i>Ceramic Antenna</i> and 128kbyte Flash Memory. No software included.
8	ENWC9A33B1EF	PAN4580ETU – 2.4GHz 802.15.4 Mesh Network Pin-Header-Module, which includes <i>UFL connector</i> and 128kbyte Flash Memory. No software included.
9	ENWC9A33A5EF	PAN4580ETU – 2.4GHz 802.15.4 Mesh Network Pin-Header-Module, which includes <i>Ceramic Antenna</i> and 128kbyte Flash Memory, with 69.5kbyte used by SNAP core, 58.5kbyte free for uploadable SNAPpy scripts. <i>Synapse SNAP software</i> included, refer also to [3].
10	ENWC9A33B5EF	PAN4580ETU – 2.4GHz 802.15.4 Mesh Network Pin-Header-Module, which includes <i>UFL connector</i> and 128kbyte Flash Memory, with 69.5kbyte used by SNAP core, 58.5kbyte free for uploadable SNAPpy scripts. <i>Synapse SNAP software</i> included, refer also to [3].

CLASSIFICATION	PRODUCT SPECIFICATION	No. DS-PAN4580-102	REV. 1.0
SUBJECT	802.15.4-MODEM	PAGE	30 of 34
CUSTOMER'S CODE PAN4580 / PAN4580ETU	PANASONIC'S CODE ENWC9A31xxEF / ENWC9A33xxEF	DATE	19.10.2012

25. ROHS DECLARATION

Declaration of environmental compatibility for supplied products:

Hereby we declare to our best present knowledge based on declaration of our suppliers that this product does not contain the following substances which are banned by Directive 2002/95/EC (RoHS) or contains a maximum concentration of 0.1% by weight in homogeneous materials for

- Lead and lead compounds
- Mercury and mercury compounds
- Chromium (VI)
- PBB (polybrominated biphenyl) category
- PBDE (polybrominated biphenyl ether) category

And a maximum concentration of 0.01% by weight in homogeneous materials for

- Cadmium and cadmium compounds

26. DATA SHEET STATUS

This data sheet contains data from the PRELIMINARY specification. Supplementary data will be published at a later date. Panasonic Electronic Devices Europe GmbH reserves the right to change the specification without notice, in order to improve the design and supply the best possible product.

Consult the most recently issued data sheet before initiating or completing a design. Use this link to check for updates: [PAN4580 Latest Data Sheet!](#)

27. REGULATORY INFORMATION

27.1. FCC NOTICE



The device PAN4580, including the ceramic antenna (ENWC9A31AxEF) and also the UFL type (ENWC9A31BxEF) and SMD type (ENWC9A31CxEF), including with the antennas, which are listed in 27.5, complies with Part 15 of the FCC Rules.

The device meets the requirements for modular transmitter approval as detailed in FCC public Notice DA00-1407. transmitter Operation is subject to the following two conditions: (1) This device may not cause harmful interference, and (2) This device must accept any interference received, including interference that may cause undesired operation.

The FCC identifier is **FCC ID: T7V-4580**.

27.2. CAUTION



The FCC requires the user to be notified that any changes or modifications made to this device that are not expressly approved by Panasonic Electronic Devices Europe GmbH may void the user's authority to operate the equipment.

This equipment has been tested and found to comply with the limits for a Class B digital device, pursuant to Part 15 of the FCC Rules. These limits are designed to provide

CLASSIFICATION	PRODUCT SPECIFICATION	No. DS-PAN4580-102	REV. 1.0
SUBJECT	802.15.4-MODEM	PAGE	31 of 34
CUSTOMER'S CODE PAN4580 / PAN4580ETU	PANASONIC'S CODE ENWC9A31xxEF / ENWC9A33xxEF	DATE	19.10.2012

reasonable protection against harmful interference in a residential installation. This equipment generates uses and can radiate radio frequency energy and, if not installed and used in accordance with the instructions, may cause harmful interference to radio communications. However, there is no guarantee that interference will not occur in a particular installation. If this equipment does cause harmful interference to radio or television reception, which can be determined by turning the equipment off and on, the user is encouraged to try to correct the interference by one or more of the following measures:

- Reorient or relocate the receiving antenna.
- Increase the separation between the equipment and receiver.
- Connect the equipment into an outlet on a circuit different from that to which the receiver is connected.
- Consult the dealer or an experienced radio/TV technician for help

27.3. LABELING REQUIREMENTS



The Original Equipment Manufacturer (OEM) must ensure that FCC labeling requirements are met. This includes a clearly visible label (laser marking) on the outside of the OEM enclosure specifying the appropriate Panasonic FCC identifier for this product as well as the FCC Notice above. The FCC identifier is **FCC ID: T7V-4580**.

In any case end product must be labelled exterior with "Contains FCC ID: T7V-4580"

27.4. ANTENNA WARNING



The related part number for this device are ENWC9A31BxEF (PAN4580 with U.FL connector) and ENWC9A31CxEF (PAN4580 with SMD pad). For details, see the chapter 24. Ordering Information. This device is tested with a standard SMA connector and with the antennas listed below. When integrated in the OEMs product, these fixed antennas require installation preventing end-users from replacing them with non-approved antennas. Any antenna not in the following table must be tested to comply with FCC Section 15.203 for unique antenna connectors and Section 15.247 for emissions. The FCC identifier for this device with the antenna listed in item 1 are the same (FCC ID: T7V-2580).

27.5. APPROVED ANTENNA LIST

Note: We are able to qualify your antenna and will add to this list as that process is completed.

Item	Part Number	Manufacturer	Frequency Band	Type	Gain (dBi)
1	LDA312G4413H-280	Murata	2.4GHz	Chip	-2.3
2					

CLASSIFICATION	PRODUCT SPECIFICATION	No. DS-PAN4580-102	REV. 1.0
SUBJECT	802.15.4-MODEM	PAGE	32 of 34
CUSTOMER'S CODE PAN4580 / PAN4580ETU	PANASONIC'S CODE ENWC9A31xxEF / ENWC9A33xxEF	DATE	19.10.2012

27.6. RF EXPOSURE PAN4580



To comply with FCC RF Exposure requirements, the Original Equipment Manufacturer (OEM) must ensure that the approved antenna in the previous table must be installed.

The preceding statement must be included as a CAUTION statement in manuals for products operating with the approved antennas in the previous table to alert users on FCC RF Exposure compliance.

Any notification to the end user of installation or removal instructions about the integrated radio module is not allowed.

The radiated output power of PAN4580 with mounted ceramic antenna (FCC ID: T7V-4580) is below the FCC radio frequency exposure limits. Nevertheless, the PAN4580 shall be used in such a manner that the potential for human contact during normal operation is minimized.

End users may not be provided with the module installation instructions. OEM integrators and end users must be provided with transmitter operating conditions for satisfying RF exposure compliance.

28. INDUSTRY CANADA CERTIFICATION

PAN4580 is licensed to meet the regulatory requirements of Industry Canada (IC), license: IC: 216Q-4580

Manufacturers of mobile, fixed or portable devices incorporating this module are advised to clarify any regulatory questions and ensure compliance for SAR and/or RF exposure limits. Users can obtain Canadian information on RF exposure and compliance from www.ic.gc.ca.

This device has been designed to operate with the antennas listed in Table 27.5 above. Antennas not included in this list are strictly prohibited for use with this device. The required antenna impedance is 50 ohms. The antenna used for this transmitter must not be co-located or operating in conjunction with any other antenna or transmitter.

29. EUROPEAN R&TTE DECLARATION OF CONFORMITY

Hereby, Panasonic Electronic Devices Europe GmbH, declares that the module PAN4580 and their versions is in compliance with the essential requirements and other relevant provisions of Directive 1999/5/EC. As a result of the conformity assessment procedure described in Annex III of the Directive 1999/5/EC, the end-customer equipment should be labelled as follows:



PAN4580 and their versions in the specified reference design can be used in the following countries: Austria, Belgium, Cyprus, Czech Republic, Denmark, Estonia, Finland, France, Germany, Greece, Hungary, Ireland, Italy, Latvia, Lithuania, Luxembourg, Malta, Poland, Portugal, Slovakia, Slovenia, Spain, Sweden, The Netherlands, the United Kingdom, Switzerland, and Norway.

CLASSIFICATION	PRODUCT SPECIFICATION	No. DS-PAN4580-102	REV. 1.0
SUBJECT	802.15.4-MODEM	PAGE	33 of 34
CUSTOMER'S CODE PAN4580 / PAN4580ETU	PANASONIC'S CODE ENWC9A31xxEF / ENWC9A33xxEF	DATE	19.10.2012

30. RELATED DOCUMENTS

For an update, please search in the suitable homepage.

- [1] IEEE Standard 802.15.4 –2003 Wireless Medium Access Control (MAC) and Physical Layer (PHY) Specifications for Low-Rate Wireless Personal Area Networks (LR-WPANS)
- [2] Technical Datasheet ATmega128RFA1
You can download the latest datasheet from the Atmel homepage [here](#).
- [3] Manual to the Evaluation Kit from Synapse, which fits to module hardware from Panasonic [Downloads: SNAP® [Reference Guide](#); SNAP® [Hardware Technical Manual](#)]
Each new release from Synapse, will be posted [here](#). Be sure to be registered free under <http://forums.synapse-wireless.com>.

31. GENERAL INFORMATION

© Panasonic Electronic Devices Europe GmbH 2012.

All rights reserved.

This product description does not claim to be complete and free of mistakes.

Please contact the related product manager with any errata inquiries.

If we deliver samples to the customer, these samples have the status Engineering Samples. This means, the design of this product is not yet completed. Engineering Samples may be partially or fully functional, and there may be differences published in the Data Sheet.

Engineering Samples are not qualified and are not to be used for reliability testing or series production.

Disclaimer:

Customer acknowledges that samples may deviate from the Data Sheet and may bear defects due to their status of development and the lack of qualification mentioned above.

Panasonic Electronic Devices Europe GmbH disclaims any liability or product warranty for Engineering Samples. In particular, Panasonic Electronic Devices Europe GmbH disclaims liability for damages caused by

- the use of the Engineering Sample other than for Evaluation Purposes, particularly the installation or integration in an other product to be sold by Customer,
- deviation or lapse in function of Engineering Sample,
- improper use of Engineering Samples.

Panasonic Electronic Devices Europe GmbH disclaims any liability for consequential and incidental damages. In case of any questions, please contact your local sales partner or the related product manager.

CLASSIFICATION	PRODUCT SPECIFICATION	No. DS-PAN4580-102	REV. 1.0
SUBJECT	802.15.4-MODEM	PAGE	34 of 34
CUSTOMER'S CODE PAN4580 / PAN4580ETU	PANASONIC'S CODE ENWC9A31xxEF / ENWC9A33xxEF	DATE	19.10.2012

32. LIFE SUPPORT POLICY

This Panasonic Electronic Devices Europe GmbH product is not designed for use in life support appliances, devices, or systems where malfunction can reasonably be expected to result in a significant personal injury to the user, or as a critical component in any life support device or system whose failure to perform can be reasonably expected to cause the failure of the life support device or system, or to affect its safety or effectiveness. Customers using or selling these products for use in such applications do so at their own risk and agree to fully indemnify Panasonic Electronic Devices Europe GmbH for any damages resulting.



Стандарт Электрон Связь

Мы молодая и активно развивающаяся компания в области поставок электронных компонентов. Мы поставляем электронные компоненты отечественного и импортного производства напрямую от производителей и с крупнейших складов мира.

Благодаря сотрудничеству с мировыми поставщиками мы осуществляем комплексные и плановые поставки широчайшего спектра электронных компонентов.

Собственная эффективная логистика и склад в обеспечивает надежную поставку продукции в точно указанные сроки по всей России.

Мы осуществляем техническую поддержку нашим клиентам и предпродажную проверку качества продукции. На все поставляемые продукты мы предоставляем гарантию .

Осуществляем поставки продукции под контролем ВП МО РФ на предприятия военно-промышленного комплекса России , а также работаем в рамках 275 ФЗ с открытием отдельных счетов в уполномоченном банке. Система менеджмента качества компании соответствует требованиям ГОСТ ISO 9001.

Минимальные сроки поставки, гибкие цены, неограниченный ассортимент и индивидуальный подход к клиентам являются основой для выстраивания долгосрочного и эффективного сотрудничества с предприятиями радиоэлектронной промышленности, предприятиями ВПК и научно-исследовательскими институтами России.

С нами вы становитесь еще успешнее!

Наши контакты:

Телефон: +7 812 627 14 35

Электронная почта: sales@st-electron.ru

Адрес: 198099, Санкт-Петербург,
Промышленная ул, дом № 19, литера Н,
помещение 100-Н Офис 331