



### Features

- Integrated 4.9GHz to 5.85GHz Amplifier, SPDT TX/RX Switch, LNA with Bypass, and Power Detector Coupler
- $P_{OUT} = 21\text{dBm}$ , 11a/n, 5V 2.5% Dynamic EVM
- $P_{OUT} = 17\text{dBm}$ , 11a/n, 3.3V 2.5% Dynamic EVM
- $P_{OUT} = 16\text{dBm}$ , 11ac HT80 MCS9, 3.3V, 1.8% Dynamic EVM
- $P_{OUT} = 18\text{dBm}$ , 11ac HT80 MCS9 5.0V, 1.8% Dynamic EVM

### Applications

- IEEE802.11a/n/ac WiFi Applications
- 4.9GHz to 5.85GHz ISM Band Applications
- Portable Battery-Powered Equipment
- WiFi Access Points, Gateways and Set Top Boxes

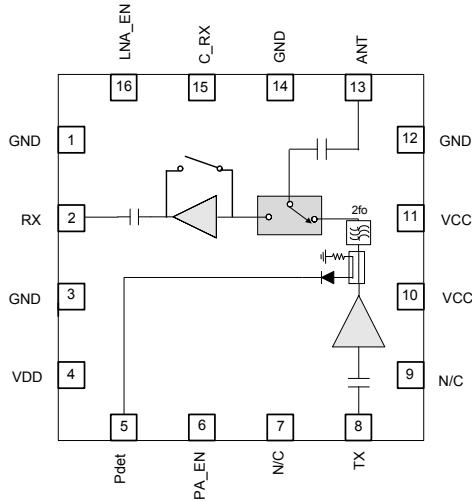

Functional Block Diagram

### Product Description

The RFFM4501 provides a complete integrated solution in a single front end module (FEM) for WiFi 802.11a/n/ac systems. The ultra-small form factor and integrated matching minimizes the layout area in the customer's application and greatly reduces the number of external components. This simplifies the total front end solution by reducing the bill of materials, system footprint, and manufacturability cost. The RFFM4501 integrates a power amplifier (PA), single pole double throw switch (SPDT), LNA with bypass, and a power detector coupler for improved accuracy. The device is provided in a 3mm x 3mm x 1.05mm, 16-pin laminate package. This module meets or exceeds the RF front end needs of IEEE 802.11a/n/ac WiFi RF systems.

### Ordering Information

RFFM4501PCK-410	RFFM4501 Eval Board with 5-piece bag
RFFM4501SB	5-Piece bag
RFFM4501SR	100-Piece reel
RFFM4501TR7	2500-Piece reel
RFFM4501SQ	25-Piece bag

### Optimum Technology Matching® Applied

- |   |                                      |  |                                    |
|---|--------------------------------------|--|------------------------------------|
| <input type="checkbox"/> GaAs HBT             | <input type="checkbox"/> SiGe BiCMOS | <input checked="" type="checkbox"/> GaAs pHEMT | <input type="checkbox"/> GaN HEMT  |
| <input type="checkbox"/> GaAs MESFET          | <input type="checkbox"/> Si BiCMOS   | <input type="checkbox"/> Si CMOS               | <input type="checkbox"/> BIFET HBT |
| <input checked="" type="checkbox"/> InGaP HBT | <input type="checkbox"/> SiGe HBT    | <input type="checkbox"/> Si BJT                |                                    |

RF MICRO DEVICES®, RFMD®, Optimum Technology Matching®, Enabling Wireless Connectivity™, PowerStart®, POLARIS™ TOTAL RADIO™ and UltimateBlue™ are trademarks of RFMD, LLC. BLUETOOTH is a trademark owned by Bluetooth SIG, Inc., U.S.A. and licensed for use by RFMD. All other trade names, trademarks and registered trademarks are the property of their respective owners. ©2012, RF Micro Devices, Inc.

## Absolute Maximum Ratings

Parameter	Rating	Unit
DC Supply Voltage (No RF)	5.5	V <sub>DC</sub>
DC Supply Voltage (With RF On)	5	V <sub>DC</sub>
Maximum Tx Input Power (No Damage)	+10	dBm
Maximum Rx Input Power for Bypass and Rx Gain Modes (No Damage)	+10	dBm
Operating Ambient Temperature	-10 to +70	°C
Extended Temperature Range	-40 to -10	°C
Storage Temperature	-40 to +150	°C
Moisture Sensitivity	MSL3	



**Caution!** ESD sensitive device.

Exceeding any one or a combination of the Absolute Maximum Rating conditions may cause permanent damage to the device. Extended application of Absolute Maximum Rating conditions to the device may reduce device reliability. Specified typical performance or functional operation of the device under Absolute Maximum Rating conditions is not implied.

The information in this publication is believed to be accurate and reliable. However, no responsibility is assumed by RF Micro Devices, Inc. ("RFMD") for its use, nor for any infringement of patents, or other rights of third parties, resulting from its use. No license is granted by implication or otherwise under any patent or patent rights of RFMD. RFMD reserves the right to change component circuitry, recommended application circuitry and specifications at any time without prior notice.



RFMD Green: RoHS compliant per EU Directive 2011/65/EU, halogen free per IEC 61249-2-21, < 1000 ppm each of antimony trioxide in polymeric materials and red phosphorus as a flame retardant, and <2% antimony in solder.

Parameter	Specification			Unit	Condition
	Min.	Typ.	Max.		
<b>Typical Conditions 3.3V</b>					Temperature = -10 °C to +70 °C, V <sub>CC</sub> = 3.3V, PA_EN = high, P <sub>OUT</sub> = 17dBm using a IEEE802.11n MCS7 waveform unless otherwise noted.
Tx Performance - 11a/n/ac					Compliance with standard 802.11a/n/ac
Frequency	5150		5850	MHz	
802.11n Output Power	16.5	17		dBm	802.11n HT20 and HT40 MCS7
11n Dynamic EVM		2.5	3	%	
		-32	-30.5	dB	
802.11ac Output Power	15	16		dBm	802.11ac HT40 and HT80 MCS9
11ac Dynamic EVM			1.8	%	
			-35	dB	
Tx Performance - Spectral Mask					
802.11n/ac Output Power		19		dBm	Meet IEEE802.11n (HT40, HT20 MCS7, and HT80 MCS9) spectral masks
Frequency	4900		5150	MHz	
802.11n Output Power	16	17		dBm	802.11n HT20 and HT40 MCS7
11n EVM		2.5	3	%	
		-32	-30.5	dB	
Second Harmonic		-45	-41	dBm/MHz	4.9GHz to 5.825GHz, P <sub>OUT</sub> = 18dBm, 6Mbps
Third Harmonic		-50	-43	dBm/MHz	802.11a
<b>General Tx Performance</b>					
Gain	24	26	30	dB	5.15GHz to 5.35GHz
	26	28	31	dB	5.35GHz to 5.825GHz
Gain variation over Temp	-2		2	dB	
Power Detect Voltage	0.35	0.375	0.4	V	RF = off
	0.70	0.75	0.8	V	P <sub>OUT</sub> = 17dBm
Power Detect Accuracy	-1.5		1.5	dB	Into 3:1 VSWR load, T = 25 °C

Parameter	Specification			Unit	Condition
	Min.	Typ.	Max.		
<b>General Tx Performance (continued)</b>					
Input Return Loss - TX_IN pin		-15	-7	dB	In specified frequency band
Output Return Loss at ANT pin		-15	-10	dB	
Operating Current		225	250	mA	P <sub>OUT</sub> = 17dBm
		220		mA	P <sub>OUT</sub> = 16dBm
Quiescent Current		175	190	mA	Nominal Conditions. No RF applied
Leakage Current			10	μA	V <sub>CC</sub> = 3.3V, LNA_EN = low, C_RX = low, PA_EN = low, temperature = 25 °C
V <sub>CONTROL</sub> High (PA_EN, C_RX, and LNA_EN) for both TX and RX modes	2.8	2.9	V <sub>CC</sub>	V	
V <sub>CONTROL</sub> Low (PA_EN, C_RX, and LNA_EN) for both TX and RX modes	0		0.2	V	
Turn-on time from PA_EN edge			500	ns	Output stable to within 90% of final gain
Turn-off time from PA_EN edge			500	ns	
Stability	-25		24	dBm	No spurs above -47dBm into 4:1 VSWR
CW P1dB	24	25		dBm	Tx mode in 50% Duty Cycle
<b>Rx Performance</b>					
					Temperature = -10 °C to +70 °C, V <sub>DD</sub> = 3.3V, C_RX = high, LNA_EN = high
Gain	11	12.5	13	dB	Temperature = 25 °C
Gain Over Operating Temperature Range	9	12.5	14	dBm	Temperature = -10 °C to +70 °C
Gain - Extended	8	12.5	16	dB	Temperature = -40 °C to +85 °C
NF		2.5	3.5	dB	In specified frequency band
Rx Port Return Loss			-7	dB	
ANT Port Return Loss		-10	-5	dB	
Input IP3	-3	0		dBm	
Input P1dB	-13	-10		dBm	
I <sub>DD</sub>		13	17	mA	
LNA_EN Control Current		30	50	μA	
<b>Rx Bypass Mode</b>					
					Temperature = -10 °C to +70 °C, V <sub>DD</sub> = 3.3V, C_RX = high, LNA_EN = low
Insertion Loss	-10	-8	-6	dB	
Rx Port Return Loss			-7	dB	
ANT Port Return Loss		-6		dB	
Input IP3	15	20		dBm	
Input P1dB	5	10		dBm	
Isolation					
ANT-TX; Rx Mode	20			dB	C_RX = High, PA_EN = Low
ANT-RX; Tx Mode	25			dB	PA_EN = High, C_RX = Low, LNA_EN = Low

Parameter	Specification			Unit	Condition
	Min.	Typ.	Max.		
<b>Typical Conditions 5.0V</b>					
Tx Performance - 11a/n/ac					Compliance with standard 802.11a/n/ac
Frequency	5150		5850	MHz	
802.11n Output Power	20	21		dBm	802.11n HT20 and HT40 MCS7
11n Dynamic EVM		2.5	3	%	
		-32	-30.5	dB	
802.11n Output Power - Extended		19		dBm	Temperature = -40°C to +85°C
11n Dynamic EVM - Extended		2.5	3	%	
		-32	-30.5	dB	
802.11ac Output Power		17		dBm	802.11ac HT40 and HT80 MCS9
11ac Dynamic EVM			1.8	%	
			-35	dB	
802.11n Output Power	20	21		dBm	Meet IEEE HT40 MCS7 Spectral Mask
Frequency	4900		5150	MHz	
802.11n Output Power		20		dBm	802.11n HT20 and HT40 MCS7
11n Dynamic EVM		2.5	3	%	
		-32	-30.5	dB	
Second Harmonic		-45	-43	dBm/MHz	4.9GHz to 5.85GHz, P <sub>OUT</sub> = 20dBm, 6Mbps 802.11a
Third Harmonic		-45	-41	dBm/MHz	
<b>General TX Performance</b>					
Gain	23	26	30	dB	5.15GHz to 5.35GHz
	26	28	31	dB	5.35GHz to 5.825GHz
Gain variation over Temp	-2		2	dB	
Power Detect Voltage	0.35	0.375	0.4	V	RF = off
	0.8	0.90	0.95	V	P <sub>OUT</sub> = 20dBm
Power Detect Accuracy	-1.5		1.5	dB	At rated power; over voltage and process up to 3:1 VSWR
Input Return Loss - TX_IN pin		-8	-6	dB	In specified frequency band
Output Return Loss at ANT pin		-15	-10	dB	
Operating Current		290	320	mA	At rated 11n P <sub>OUT</sub>
Quiescent Current		200	220	mA	Nominal Conditions, No RF applied
Leakage Current			25	μA	V <sub>CC</sub> = 5V, PA_EN = low, C_RX = low, LNA_EN = low
Power Supply - V <sub>CC</sub>		5		V	
V <sub>CONTROL</sub> High (PA_EN, C_RX, LNA_EN) for both TX and RX modes	2.8	2.9	V <sub>CC</sub>	V	For best performance at V <sub>CC</sub> = 5.0V, PA_EN should be set to 2.9V
V <sub>CONTROL</sub> Low (PA_EN, C_RX, LNA_EN) for both TX and RX modes	0		0.2	V	
Turn-on time from PA_EN edge			500	ns	Output stable to within 90% of final gain
Turn-off time from PA_EN edge			500	ns	
Stability	-25		24	dBm	No spurs above -47dBm into 4:1 VSWR
CW P1dB		28		dBm	Tx mode in 50% Duty Cycle
<b>Rx Performance</b>					
Temperature = -10°C to +70°C, V <sub>DD</sub> = 5.0V, C_RX = high, LNA_EN = high					
Gain	11	12.5	13	dB	
Gain - Extended	8	12.5	16	dB	Temperature = -40°C to +85°C

Parameter	Specification			Unit	Condition
	Min.	Typ.	Max.		
<b>Rx Performance (continued)</b>					Temperature = -10°C to +70°C, V <sub>DD</sub> = 5.0V, C_RX = high, LNA_EN = high
NF		2.5	3.5	dB	In specified frequency band
Rx Port Return Loss		-15	-7	dB	
ANT Port Return Loss		-10	-5	dB	
Input IP3	-3	0		dBm	
Input P1dB	-13	-10		dBm	
I <sub>DD</sub>		13	17	mA	
LNA_EN Control Current		30	50	μA	
<b>Rx Bypass Mode</b>					Temperature = -10°C to +70°C, V <sub>DD</sub> = 5.0V, C_RX = high, LNA_EN = low
Insertion Loss	-10	-8	-6	dB	
Rx Port Return Loss		-10	-8	dB	
ANT Port Return Loss		-6		dB	
Input IP3	15	20		dBm	
Input P1dB	5	10		dBm	
Isolation					
ANT-TX; Rx Mode	20			dB	C_RX = High, PA_EN = Low
ANT-RX; Tx Mode	25			dB	PA_EN = High, C_RX = Low, LNA_EN = Low

Parameter	Specification			Unit	Condition
	Min.	Typ.	Max.		
<b>Typical Conditions 5.0V</b>					
Tx Performance - 11a/n/ac					Compliance with standard 802.11a/n/ac
Frequency	5150		5850	MHz	
802.11n Output Power	20	21		dBm	802.11n HT20 and HT40 MCS7
11n Dynamic EVM		2.5	3	%	
		-32	-30.5	dB	
802.11n Output Power - Extended		19.5		dBm	Temperature = -40°C to +85°C
11n Dynamic EVM - Extended		2.5	3	%	
		-32	-30.5	dB	
802.11ac Output Power		18		dBm	802.11ac HT40 and HT80 MCS9
11ac Dynamic EVM			1.8	%	
			-35	dB	
802.11n Output Power	20	22		dBm	Meet IEEE HT40 MCS7 Spectral Mask
Frequency	4900		5150	MHz	
802.11n Output Power		21		dBm	802.11n HT20 and HT40 MCS7
11n Dynamic EVM		2.5	3	%	
		-32	-30.5	dB	
Second Harmonic		-45	-43	dBm/MHz	4.9GHz to 5.85GHz, P <sub>OUT</sub> = 20dBm, 6Mbps
Third Harmonic		-45	-41	dBm/MHz	802.11a
<b>General TX Performance</b>					
Gain	24	26	30	dB	5.15GHz to 5.35GHz
	26	28	31	dB	5.35GHz to 5.825GHz
Gain variation over Temp	-2		2	dB	
Power Detect Voltage	0.35	0.375	0.4	V	RF = off
	0.8	0.90	0.95	V	P <sub>OUT</sub> = 20dBm
Power Detect Accuracy	-1.5		1.5	dB	At rated power; over voltage and process up to 3:1 VSWR
Input Return Loss - TX_IN pin		-15	-9	dB	In specified frequency band
Output Return Loss at ANT pin		-15	-10	dB	
Operating Current		290	320	mA	At rated 11n P <sub>OUT</sub>
Quiescent Current		200	220	mA	Nominal Conditions, No RF applied
Leakage Current			25	μA	V <sub>CC</sub> = 5V, PA_EN = low, C_RX = low, LNA_EN = low
Power Supply - V <sub>CC</sub>		5		V	
V <sub>CONTROL</sub> High (PA_EN, C_RX, LNA_EN) for both TX and RX modes	2.8	3.3	V <sub>CC</sub>	V	For best performance at V <sub>CC</sub> = 5.0V, PA_EN should be set to 5.0V
V <sub>CONTROL</sub> Low (PA_EN, C_RX, LNA_EN) for both TX and RX modes	0		0.2	V	
Turn-on time from PA_EN edge			500	ns	Output stable to within 90% of final gain
Turn-off time from PA_EN edge			500	ns	
Stability	-25		24	dBm	No spurs above -47dBm into 4:1 VSWR
CW P1dB		28		dBm	Tx mode in 50% Duty Cycle
<b>Rx Performance</b>					
Temperature = -10°C to +70°C, V <sub>DD</sub> = 5.0V, C_RX = high, LNA_EN = high					
Gain	11	12.5	13	dB	
Gain - Extended	8	12.5	16	dB	Temperature = -40°C to +85°C

Parameter	Specification			Unit	Condition
	Min.	Typ.	Max.		
<b>Rx Performance (continued)</b>					Temperature = -10 °C to +70 °C, V <sub>DD</sub> = 5.0V, C_RX = high, LNA_EN = high
NF		2.5	3.5	dB	In specified frequency band
Rx Port Return Loss		-15	-7	dB	
ANT Port Return Loss		-10	-5	dB	
Input IP3	-3	0		dBm	
Input P1dB	-13	-10		dBm	
I <sub>DD</sub>		13	17	mA	
LNA_EN Control Current		30	50	μA	
<b>Rx Bypass Mode</b>					Temperature = -10 °C to +70 °C, V <sub>DD</sub> = 5.0V, C_RX = high, LNA_EN = low
Insertion Loss	-10	-8	-6	dB	
Rx Port Return Loss		-10	-8	dB	
ANT Port Return Loss		-6		dB	
Input IP3	15	20		dBm	
Input P1dB	5	10		dBm	
Isolation					
ANT-TX; Rx Mode	20			dB	C_RX = High, PA_EN = Low
ANT-RX; Tx Mode	25			dB	PA_EN = High, C_RX = Low, LNA_EN = Low
<b>General Performance</b>					
Control Current					
C_RX Current		0.5	1	μA	
PA_EN Current		30	50	μA	
Switch Control Speed			100	ns	
PA_EN Control Impedance		4.9		MΩ	
LNA_EN Control Impedance		6.5		MΩ	
C_RX Control Impedance		27		MΩ	
ESD					
Human Body Model	500			V	EIA/JESD22-114A RF pins
	1000			V	EIA/JESD22-114A DC pins
Charge Device Model	1000			V	JESD22-C101C all pins
Thermal Resistance					
R <sub>TH_L</sub>		46		°C/W	
Maximum T <sub>j</sub>			150	°C	V <sub>CC</sub> = 5.0V, Temperature = 85 °C, Duty cycle 100%, P <sub>OUT</sub> = 21dBm
Maximum Input Power			12	dBm	Into 50Ω, V <sub>CC</sub> = 3.3V, 25 °C
Maximum Input Power			12	dBm	6:1 VSWR, V <sub>CC</sub> = 3.3V, 25 °C
Maximum Input Power			5	dBm	10:1 VSWR, V <sub>CC</sub> = 3.3V, 25 °C

**Logic Control Table**

Mode	PA_EN	LNA_EN	C_RX
Standby	Low	Low	Low
802.11a/n TX	High	Low	Low
802.11a/n RX Gain	Low	High	High
802.11a/n RX Bypass	Low	Low	High

 Note: High = 2.8V to V<sub>CC</sub>; Low = 0V to 0.2V

**Pin Names and Descriptions**

Pin	Name	Description
1	GND	Ground connection.
2	RX	RF output port for the 802.11a/n LNA. Input is matched to 50Ω and DC block is provided internally.
3	GND	Ground connection.
4	VDD	Supply voltage for the LNA. See applications schematic for biasing and bypassing components.
5	PDET	Power detector voltage for Tx section. PDET voltage varies with output power. May need external capacitor for noise decoupling.
6	PA_EN	Control voltage for the PA and Tx switch. See truth table for proper settings.
7	NC	Not Connected. This Pin is not internally connected so customer has the choice to leave it NC or ground it.
8	TX	RF input port for the 802.11a/n PA. Input is matched to 50Ω and DC block is provided internally.
9	NC	Not Connected. This Pin is not internally connected so customer has the choice to leave it NC or ground it.
10	VCC	Supply voltage for the PA. See applications schematic for biasing and bypassing components.
11	VCC	Supply voltage for the PA. See applications schematic for biasing and bypassing components.
12	GND	Ground connection.
13	ANT	RF bidirectional antenna port matched to 50Ω and is DC block is provided internally.
14	GND	Ground connection.
15	C_RX	Receive switch control pin. See switch truth table for proper level.
16	LNA_EN	Control voltage for the LNA. When this pin is set to a LOW logic state, the bypass mode is enabled.
Pkg Base	GND	Ground connection.



**Package Drawing**

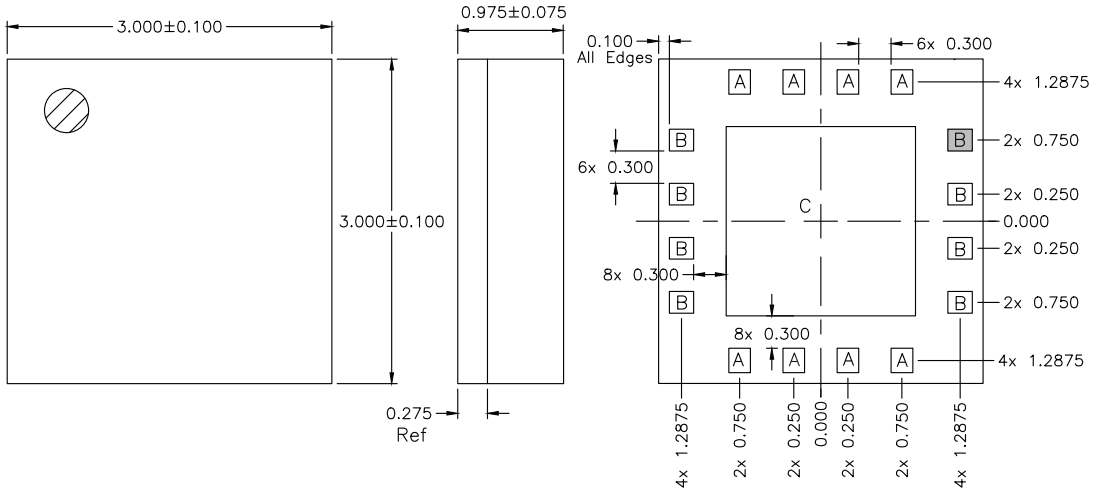

Notes:

1. Shaded area represents Pin 1 location.

A = 0.200 x 0.225 mm  
 B = 0.225 x 0.200 mm  
 C = 1.750 x 1.750 mm

**PCB Patterns**

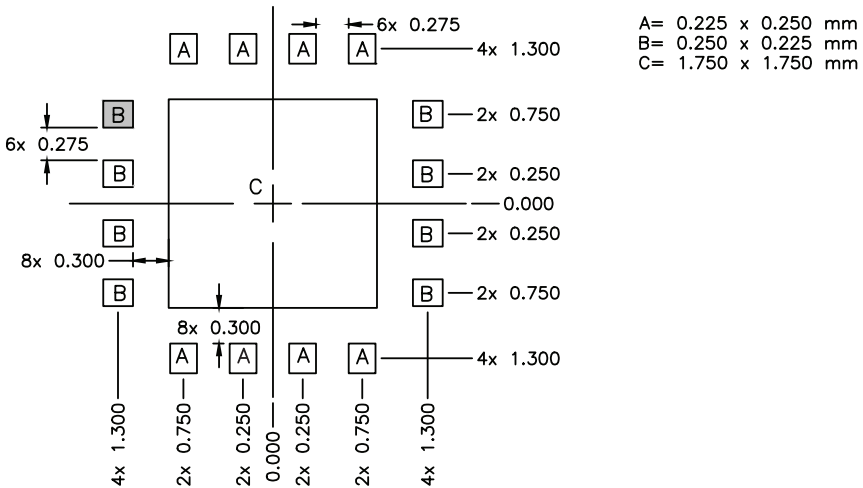

Notes:

1. Shaded area represents Pin 1 location.
2. Example of the number and size of vias can be found on the RFMD evaluation board layout.

## Pin Out

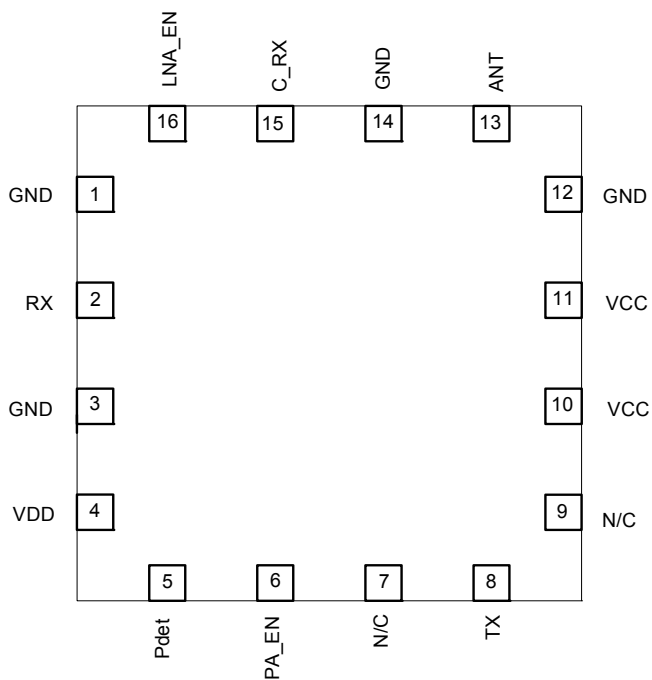

**Evaluation Board Schematic**

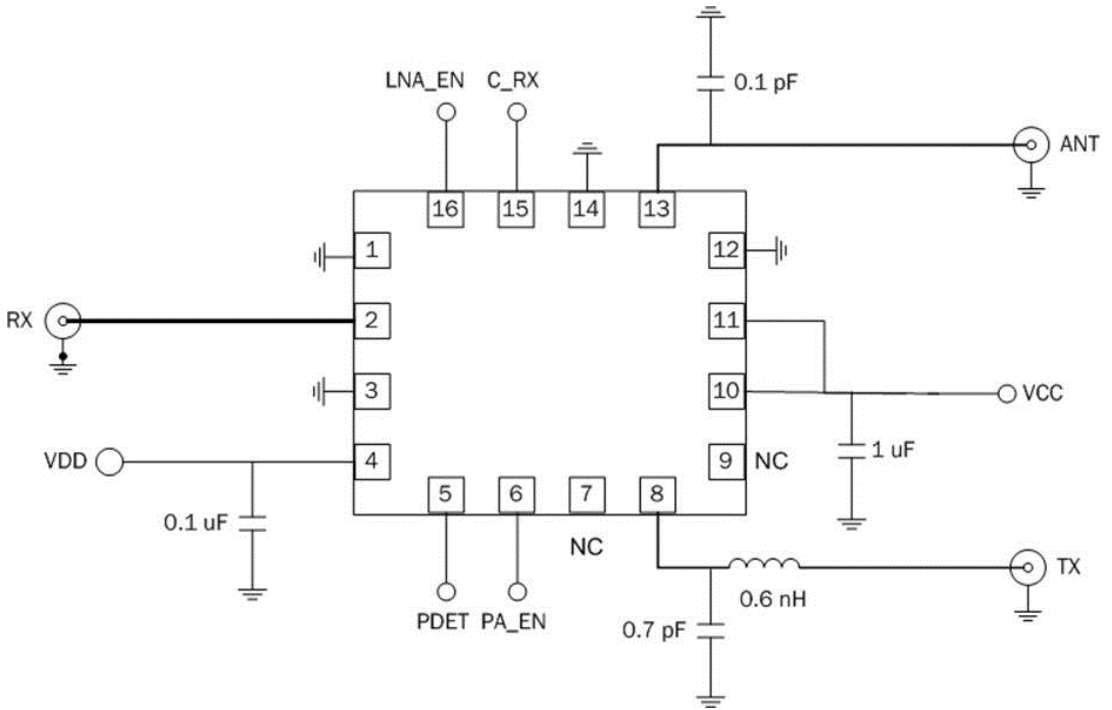



## Стандарт Электрон Связь

Мы молодая и активно развивающаяся компания в области поставок электронных компонентов. Мы поставляем электронные компоненты отечественного и импортного производства напрямую от производителей и с крупнейших складов мира.

Благодаря сотрудничеству с мировыми поставщиками мы осуществляем комплексные и плановые поставки широчайшего спектра электронных компонентов.

Собственная эффективная логистика и склад в обеспечивает надежную поставку продукции в точно указанные сроки по всей России.

Мы осуществляем техническую поддержку нашим клиентам и предпродажную проверку качества продукции. На все поставляемые продукты мы предоставляем гарантию .

Осуществляем поставки продукции под контролем ВП МО РФ на предприятия военно-промышленного комплекса России , а также работаем в рамках 275 ФЗ с открытием отдельных счетов в уполномоченном банке. Система менеджмента качества компании соответствует требованиям ГОСТ ISO 9001.

Минимальные сроки поставки, гибкие цены, неограниченный ассортимент и индивидуальный подход к клиентам являются основой для выстраивания долгосрочного и эффективного сотрудничества с предприятиями радиоэлектронной промышленности, предприятиями ВПК и научно-исследовательскими институтами России.

С нами вы становитесь еще успешнее!

### Наши контакты:

**Телефон:** +7 812 627 14 35

**Электронная почта:** [sales@st-electron.ru](mailto:sales@st-electron.ru)

**Адрес:** 198099, Санкт-Петербург,  
Промышленная ул, дом № 19, литера Н,  
помещение 100-Н Офис 331