

3.0V 3F ULTRACAPACITOR CELL

BCAP0003 P300 X11 / X12

Advanced Small Cell with XP™ Technology



Maxwell Technologies' 3V 3F ultracapacitor cell is part of Maxwell's latest full-featured 3.0V product platform designed to provide energy storage in support of the latest trends in renewable energy, smart grid, and IoT. Designed from the ground up, Maxwell developed the 3V small cell products to be high energy, high power solutions that also incorporate the XP™ technology offering enhanced performance under adverse environmental conditions. Whether used alone, integrated into a module assembly, or in a hybrid configuration, Maxwell's 3V products will help reduce the overall cost and size of the system while improving return on investments for the customer.

Ultracapacitors are the technology of choice for high energy and high power applications because of their longer operating lifetime, low maintenance requirements, and superior cold weather performance when compared to batteries.

FEATURES AND BENEFITS

- Enhanced performance under adverse environmental conditions
- Updated Bill of Materials compared to earlier 2.7V XP products resulting in improved performance at higher voltage
- Long lifetimes with up to 1,000,000 duty cycles*
- Straight and Bent Lead versions available
- Compliant with UL, RoHS and REACH requirements

TYPICAL APPLICATIONS

- Actuators
- Emergency Lighting
- Telematics / IoT
- Automotive
- Security Equipment
- Backup and UPS Systems
- Advanced Metering

ORDERING INFORMATION

Model Number	Part Number	Package Quantity (MOQ)
BCAP0003 P300 X11	134995	6,000
BCAP0003 P300 X12	134996	5,040

*Results may vary. Additional terms and conditions, including the limited warranty, apply at the time of purchase. See the warranty details for applicable operating and use requirements.

PRODUCT SPECIFICATIONS & CHARACTERISTICS

Values are referenced at T_A = room temperature and V_R = 3.0V rated voltage (unless otherwise noted). Min and Max values indicate product specifications. Typical results will vary and are provided for reference only. Additional terms and conditions, including the limited warranty, apply at the time of purchase. See the warranty details for applicable operating and use requirements.

Symbol	Parameter	Conditions	Min	Typical	Max	Unit
ELECTRICAL						
V_R	Rated Voltage		–	–	3.0	V
V_{SURGE}	Surge Voltage	Note 1	–	–	3.15	V
C_R	Rated Capacitance	BOL, Note 2,8	2.7	3.0	3.6	F
R_S	Equivalent Series Resistance (ESR_{DC})	BOL, Note 2,8	–	62	95	m Ω
I_{LEAK}	Leakage Current	Note 3,8	–	–	7	μ A
I_{PEAK}	Peak Current	BOL, Note 4,8	–	–	3.5	A
I_{MAX}	Continuous Current	BOL, Note 7,8 - $\Delta T = 15^\circ\text{C}$ - $\Delta T = 40^\circ\text{C}$	– –	– –	1.4 2.3	A_{RMS}
LIFE						
t_{65C}	High Temperature Life	$V_R = 3V$ and $T_A = 65^\circ\text{C}$, EOL, Note 8 - Capacitance change ΔC from min C_R - Resistance change ΔR from max R_S	– – –	1,500 -20 +100	– – –	hours % %
t_{85C}	De-rated Voltage & Higher Temperature Life	$V_R = 2.7V$ and $T_A = 85^\circ\text{C}$, EOL, Note 8 - Capacitance change ΔC from min C_R - Resistance change ΔR from max R_S	– – –	1,000 -20 +100	– – –	hours % %
t_{25C}	Projected Life Time	$V_R = 3V$ and $T_A = 25^\circ\text{C}$, EOL, Note 8 - Capacitance change ΔC from min C_R - Resistance change ΔR from max R_S	– – –	10 -20 +100	– – –	years % %
n_{CYCLE}	Projected Cycle Life	$T_A = 25^\circ\text{C}$, EOL, Note 6,8 - Capacitance change ΔC from min C_R - Resistance change ΔR from max R_S	– – –	1,000,000 -20 +100	– – –	cycles % %
h_{LIFE}	Biased Humidity Life	$V_R = 3V$, $T_A = 60^\circ\text{C}$, and $RH = 90\%$	–	4,000	–	hours
t_{SHELF}	Shelf Life	Stored uncharged, $T_A = 25^\circ\text{C}$ and $RH \leq 50\%$	–	4	–	years

PRODUCT SPECIFICATIONS & CHARACTERISTICS

Values are referenced at T_A = room temperature and V_R = 3.0V rated voltage (unless otherwise noted). Min and Max values indicate product specifications. Typical results will vary and are provided for reference only. Additional terms and conditions, including the limited warranty, apply at the time of purchase. See the warranty details for applicable operating and use requirements.

Symbol	Parameter	Conditions	Min	Typical	Max	Unit
POWER & ENERGY						
P_d	Usable Specific Power	BOL, Note 5,8	–	8.1	–	kW/kg
P_{MAX}	Impedance Match Specific Power	BOL, Note 5,8	–	16.9	–	kW/kg
E_d	Gravimetric Specific Energy	BOL, Note 5,8	–	2.7	–	Wh/kg
E_{MAX}	Stored Energy	BOL, Note 5,8,9	–	3.8	–	mWh
TEMPERATURE						
T_A	Operating Temperature	Cell case temperature	-40	25	65	°C
R_{th}	Thermal Resistance	Case to ambient, Note 7	–	83	–	°C/W
C_{th}	Thermal Capacitance		–	1.3	–	J/°C
PHYSICAL						
m	Mass		–	1.4	–	g
–	Vibration – Sine Wave		IEC 60068-2-6			–
–	Shock		IEC 60068-2-27			–
SAFETY						
–	Certifications		UL810A, RoHS, REACH			

NOTES

- Surge Voltage**
Absolute maximum voltage, non-repetitive. The duration must not exceed 1 second.
- Rated Capacitance & ESR_{DC} (Measurement Method)**
 - Capacitance: Constant current charge (10mA/F) to V_R, 5 min hold at V_R, constant current discharge (10mA/F) to 0.1V.
 - ESR_{DC}: Constant current charge (10mA/F) to V_R, 5 min hold at V_R, constant current discharge (40 * C_R * V_R [mA]) to 0.1V.

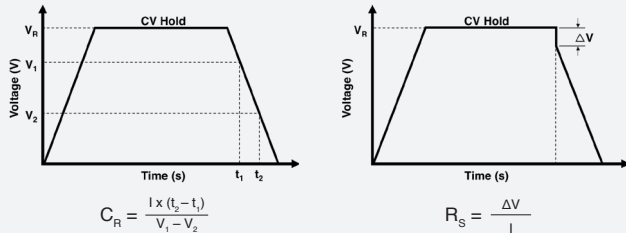

where C_R is the capacitance (F);
I is the absolute value of the discharge current (A);
V_R is the rated voltage (V);
V₁ is the measurement starting voltage, 0.8 X V_R (V);
V₂ is the measurement end voltage, 0.4 X V_R (V);
t₁ is the time from discharge start to reach V₁ (s);
t₂ is the time from discharge start to reach V₂ (s);
R_S is the DC equivalent series resistance (Ω);
ΔV is the voltage drop during first 10ms of discharge (V).

- Leakage Current (Measurement Method)**
 - Current measured after 72 hours of constant voltage hold at V_R and 25°C. Initial leakage current can be higher.
 - If applicable, module leakage current is the sum of cell leakage current and bypass current created by balancing circuit.

- Peak Current**
 - Current needed to discharge cell or module from V_R to 1/2V_R in 1 second.

$$I_{PEAK} = \frac{\frac{1}{2}V_R}{\Delta t / C_R + R_S}$$

where I_{PEAK} is the maximum peak current (A);
V_R is the rated voltage (V);
Δt is the discharge time (sec); Δt = 1 sec in this case;
C_R is the rated BOL capacitance (F);
R_S is the maximum BOL ESR_{DC} (Ω).

- The stated peak current should not be used in normal operation and is provided as a reference value only.

- Energy & Power (Based on IEC 62576)**

- Usable Specific Power, P_d (W/kg) = $\frac{0.12V_R^2}{R_S \times m}$
- Impedance Match Specific Power, P_{MAX} (W/kg) = $\frac{0.25V_R^2}{R_S \times m}$
- Gravimetric Specific Energy, E_d (Wh/kg) = $\frac{E_{MAX}}{m}$
- Stored Energy, E_{MAX} (Wh) = $\frac{\frac{1}{2}C_R \times V_R^2}{3,600}$

where V_R is the rated voltage (V);
R_S is the maximum BOL ESR_{DC} (Ω);
m is the typical mass (kg);
C_R is the rated BOL capacitance (F).

- Projected Cycle Life**
 - Constant current charge-discharge cycle from V_R to 1/2V_R at 25°C.
 - Cycle life is dependent upon application-specific characteristics. Actual results will vary.
- Continuous Current & Thermal Resistance**
 - Maximum current which can be used continuously within the allowed temperature range.

$$I_{MAX} = \sqrt{\frac{\Delta T}{R_{th} \times R_S}}$$

where I_{MAX} is the maximum continuous current (A);
ΔT is the change in temperature (°C);
R_{th} is the typical thermal resistance (°C/W);
R_S is the maximum BOL ESR_{DC} (Ω).

- BOL & EOL Conditions**
 - BOL (Beginning of Life): Rated/Initial product performance
 - EOL (End of Life):
 - Capacitance: 80% of min. BOL rating (0.8 x min. C_R)
 - ESR_{DC}: 200% of max. BOL rating (2 x max. R_S)
- Transportation Regulation**
 - Per United Nations material classification UN3499, all Maxwell ultracapacitor cells have less than 10Wh stored energy to meet the requirements of Special Provisions 361. Both individual ultracapacitors and modules composed of ultracapacitors shipped by Maxwell can be transported without being treated as dangerous goods (hazardous materials) under transportation regulations.

DETAILED PRODUCT DESCRIPTION

Introduction

The BCAP0003 P300 X11 / X12 energy storage cell is a robust ultracapacitor solution in a leaded cylindrical style can. The 3.0V 3F cell design uses Maxwell's proprietary XP™ high heat and humidity environmental technology to provide maximum life under adverse conditions.

Technology Overview

Ultracapacitor, also known as supercapacitor or electric double layer capacitor (EDLC), delivers energy at relatively high rates (beyond those accessible with batteries). Ultracapacitors store charge electrostatically (non-Faradaic) by reversible adsorption of the electrolyte onto electrochemically stable high surface area carbon electrodes. Charge separation occurs on polarization at the electrode/electrolyte interface, producing a double layer. This mechanism is highly reversible, allowing the ultracapacitor to be charged and discharged hundreds of thousands of times.*

Ultracapacitor Construction

An ultracapacitor is constructed with symmetric carbon positive and negative electrodes separated by an insulating ion-permeable separator and packaged into a container filled with organic electrolyte (salt/solvent) designed to maximize ionic conductivity and electrode wetting. It is the combination of high surface-area activated carbon electrodes (typically >1500m²/g) with extremely small charge separation (Angstroms) that results in high capacitance.

*Results may vary. Additional terms and conditions, including the limited warranty, apply at the time of purchase. See the warranty details for applicable operating and use requirements.

Ultracapacitor Energy = ½ CV²

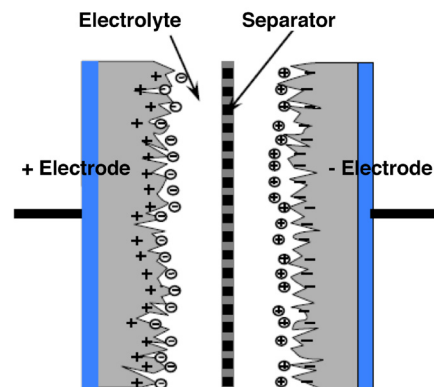
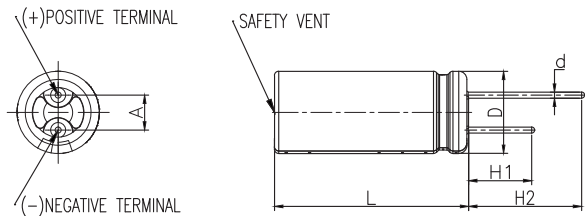

Figure 1: Ultracapacitor Structure Diagram

MECHANICAL DRAWINGS

BCAP0003 P300 X11



BCAP0003 P300 X12

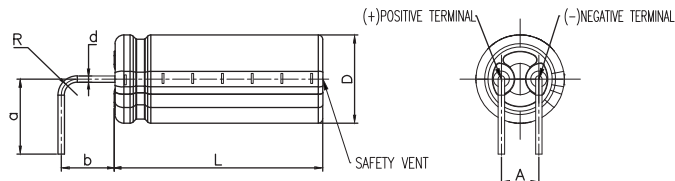

DIMENSION (Tolerance)	L (±1.0)	D (+0.5)	d (±0.05)	A (±0.5)	H1 (min)	H2 (min)	R (min)	a (±0.5)	b (±0.5)	UNIT
BCAP0003 P300 X11	19.5	8.0	0.60	3.5	15.0	19.0				mm
BCAP0003 P300 X12	19.5	8.0	0.60	3.5			1.5	7.0	5.0	mm

Products and related processes may be covered by one or more U.S. or international patents and pending applications. Please see www.maxwell.com/patents for more information. Product dimensions are for reference only unless otherwise identified. Maxwell Technologies reserves the right to make changes without further notice to any products herein. "Typical" parameters which may be provided in Maxwell Technologies datasheets and/or specifications can and do vary in different applications and actual performance may vary over time. All operating parameters, including "Typicals" must be validated for each customer application by customer's technical experts. Please contact Maxwell Technologies directly for any technical specifications critical to application.

Maxwell Technologies, Inc.
Global Headquarters
 3888 Calle Fortunada
 San Diego, CA 92123
 USA
 Tel: +1 (858) 503-3300
 Fax: +1 (858) 503-3301

Maxwell Technologies, GmbH
 Leopoldstrasse 244
 80807 Munich
 Germany
 Tel: +49 (0)89 4161403 0
 Fax: +49 (0)89 4161403 99

**Maxwell Technologies
 Shanghai Trading Co., Ltd.**
 Room 1005, 1006, and 1007
 No. 1898, Gonghexin Road,
 Jin An District, Shanghai 2000072,
 P.R. China
 Tel: +86 21 3852 4000
 Fax: +82 21 3852 4099

**Maxwell Technologies
 Korea Co., Ltd.**
 17, Dongtangiheung-ro
 681 Beon-gil, Giheung-gu,
 Yongin-si, Gyeonggi-do 17102
 Republic of Korea
 Tel: +82 31 289 0721
 Fax: +82 31 286 6767

MAXWELL TECHNOLOGIES, MAXWELL, MAXWELL CERTIFIED INTEGRATOR, ENABLING ENERGY'S FUTURE, DURABLU, NESSCAP, XP, BOOSTCAP, D CELL and their respective designs and/or logos are either trademarks or registered trademarks of Maxwell Technologies, Inc., and/or its affiliates, and may not be copied, imitated or used, in whole or in part, without the prior written permission Maxwell Technologies, Inc. All contents copyright © 2019 Maxwell Technologies, Inc. All rights reserved. No portion of these materials may be reproduced in any form, or by any means, without prior written permission from Maxwell Technologies, Inc.



Стандарт Электрон Связь

Мы молодая и активно развивающаяся компания в области поставок электронных компонентов. Мы поставляем электронные компоненты отечественного и импортного производства напрямую от производителей и с крупнейших складов мира.

Благодаря сотрудничеству с мировыми поставщиками мы осуществляем комплексные и плановые поставки широчайшего спектра электронных компонентов.

Собственная эффективная логистика и склад в обеспечивает надежную поставку продукции в точно указанные сроки по всей России.

Мы осуществляем техническую поддержку нашим клиентам и предпродажную проверку качества продукции. На все поставляемые продукты мы предоставляем гарантию .

Осуществляем поставки продукции под контролем ВП МО РФ на предприятия военно-промышленного комплекса России , а также работаем в рамках 275 ФЗ с открытием отдельных счетов в уполномоченном банке. Система менеджмента качества компании соответствует требованиям ГОСТ ISO 9001.

Минимальные сроки поставки, гибкие цены, неограниченный ассортимент и индивидуальный подход к клиентам являются основой для выстраивания долгосрочного и эффективного сотрудничества с предприятиями радиоэлектронной промышленности, предприятиями ВПК и научно-исследовательскими институтами России.

С нами вы становитесь еще успешнее!

Наши контакты:

Телефон: +7 812 627 14 35

Электронная почта: sales@st-electron.ru

Адрес: 198099, Санкт-Петербург,
Промышленная ул, дом № 19, литера Н,
помещение 100-Н Офис 331