

THIS DRAWING IS UNPUBLISHED. RELEASED FOR PUBLICATION 20
 © COPYRIGHT 20 BY - ALL RIGHTS RESERVED.

LOC		DIST		REVISIONS			
P	LTR	DESCRIPTION	DATE	DWN	APVD		
-	-	A	REVISED PER ECR-12-002666	08AUG2012	RS	MM	

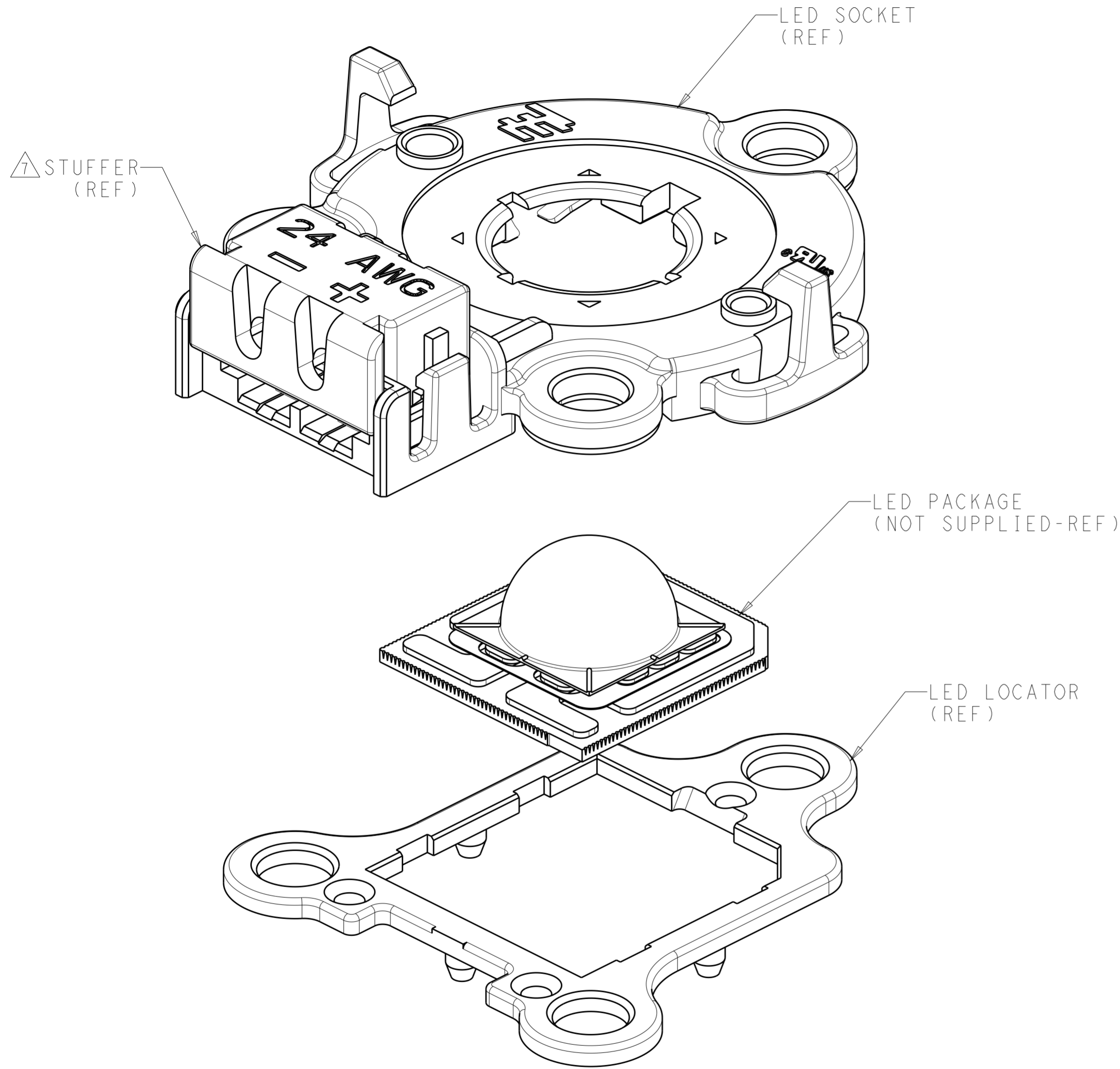

EXPLODED VIEW WITH LED SHOWN
 SCALE 6:1

- 1 MATERIALS AND FINISH:
 - HOUSING: PBT-GF, COLOR: NATURAL
 - LED LOCATOR: PBT-GF, COLOR: NATURAL
 - STUFFER: PBT-GF, COLOR: NATURAL
 - IDC CONTACTS: COPPER ALLOY
 - FINISH: GOLD IN LED INTERFACE WITH TIN OVER NICKEL BALANCE
 - THERMAL SPRING: STAINLESS STEEL
- 2. MUST COMPLY WITH DIRECTIVE 2002/95/EC (ROHS)
- 3. THIS PRODUCT HAS NOT COMPLETED VALIDATION TESTING
- 4 REFER TO LUMILEDS LED DATASHEET FOR LED DIMENSIONS
- 5 REFER TO LUMILEDS LED DATASHEET FOR RECOMMENDED THERMAL INTERFACE MATERIALS
- 6 RECOMMENDED SCREW SIZE: M3 OR #4. TORQUE SCREWS TO 2.5 in-lbf TO 4.0 in-lbf
- 7 SOCKET TO BE USED WITH 24AWG UL1007/1569 INSULATED WIRE. MAX INSULATION O.D. TO BE Ø1.60

SOCKET ASSEMBLY W/ OPTICS LATCH	2154235-2
SOCKET ASSEMBLY W/O OPTICS LATCH	2154235-1
DESCRIPTION	PART NO.

THIS DRAWING IS A CONTROLLED DOCUMENT.		DWN C. DAILY 14OCT2010	TE Connectivity	
		CHK R. NARANG 14OCT2010		
DIMENSIONS: mm		APVD -		NAME ASSEMBLY, SOLDERLESS LED SOCKET, TYPE LS
TOLERANCES UNLESS OTHERWISE SPECIFIED:		PRODUCT SPEC 108-2455		
0 PLC ±-		APPLICATION SPEC 114-13294		SIZE A200779
1 PLC ±0.2		WEIGHT -		CAGE CODE C-2154235
2 PLC ±0.15		MATERIAL -		DRAWING NO -
3 PLC ±-		Customer Drawing		RESTRICTED TO -
4 PLC ±-		SCALE 4:1		SHEET 1 OF 4
ANGLES ±2°		REV A		
FINISH				

THIS DRAWING IS UNPUBLISHED. RELEASED FOR PUBLICATION 20
 © COPYRIGHT 20 BY - ALL RIGHTS RESERVED.

REVISIONS							
LOC	DIST	P	LTR	DESCRIPTION	DATE	DWN	APVD
-	-	-	-	SEE SHEET 1	-	-	-

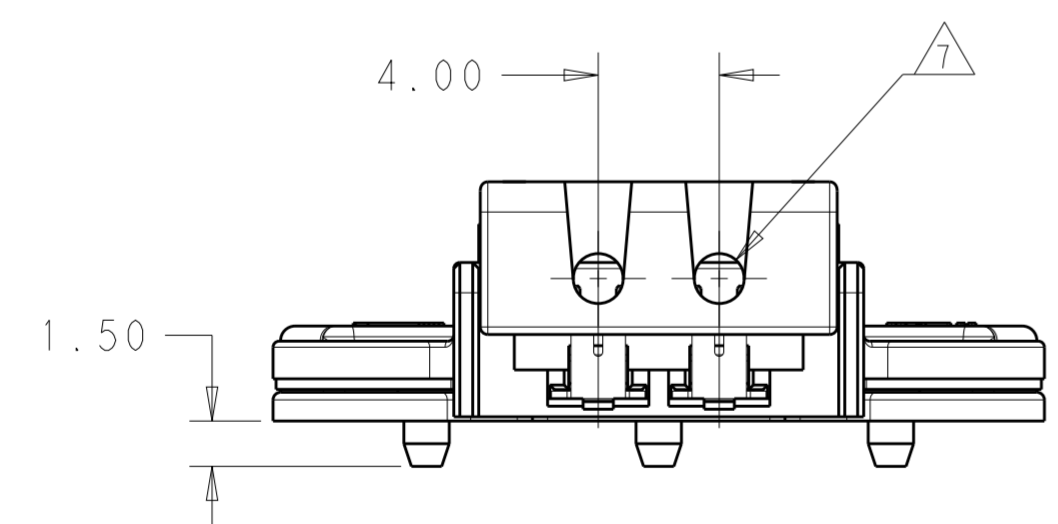
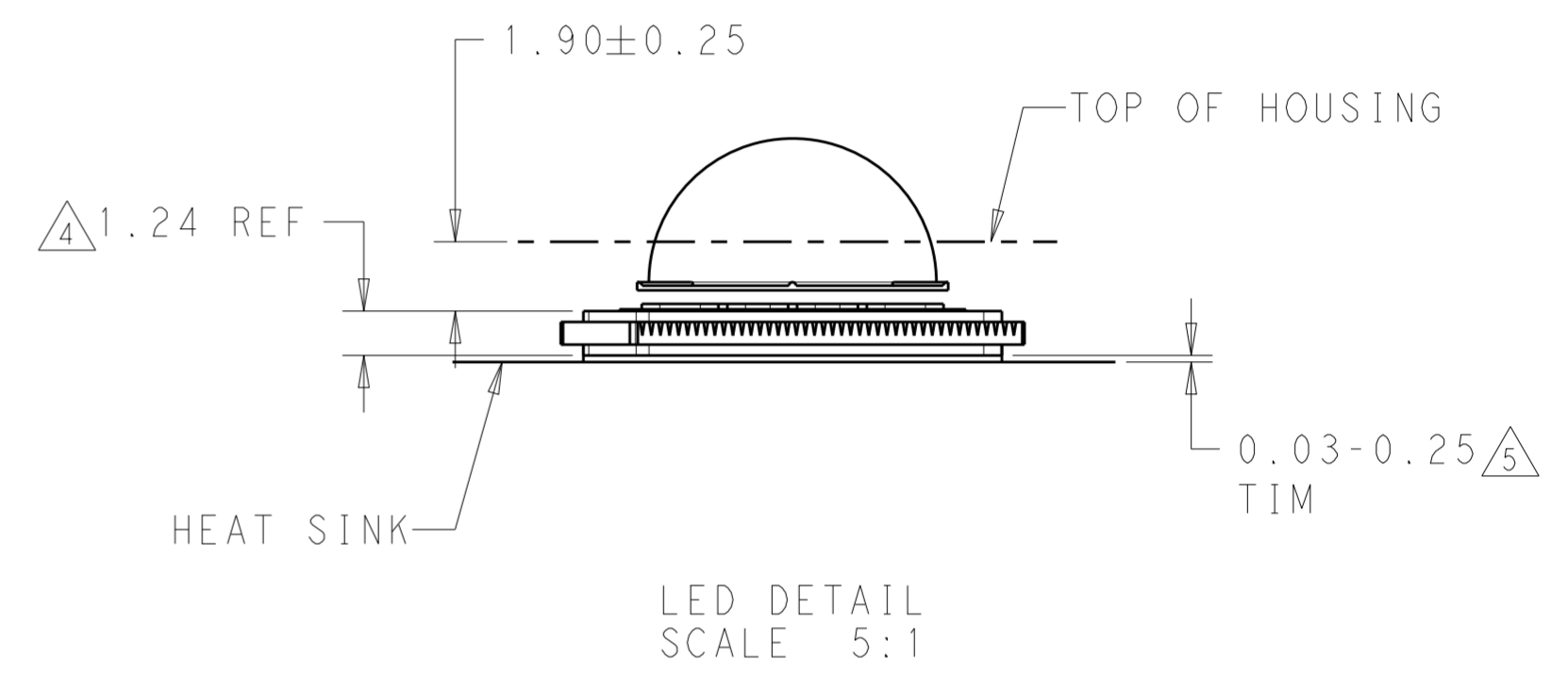
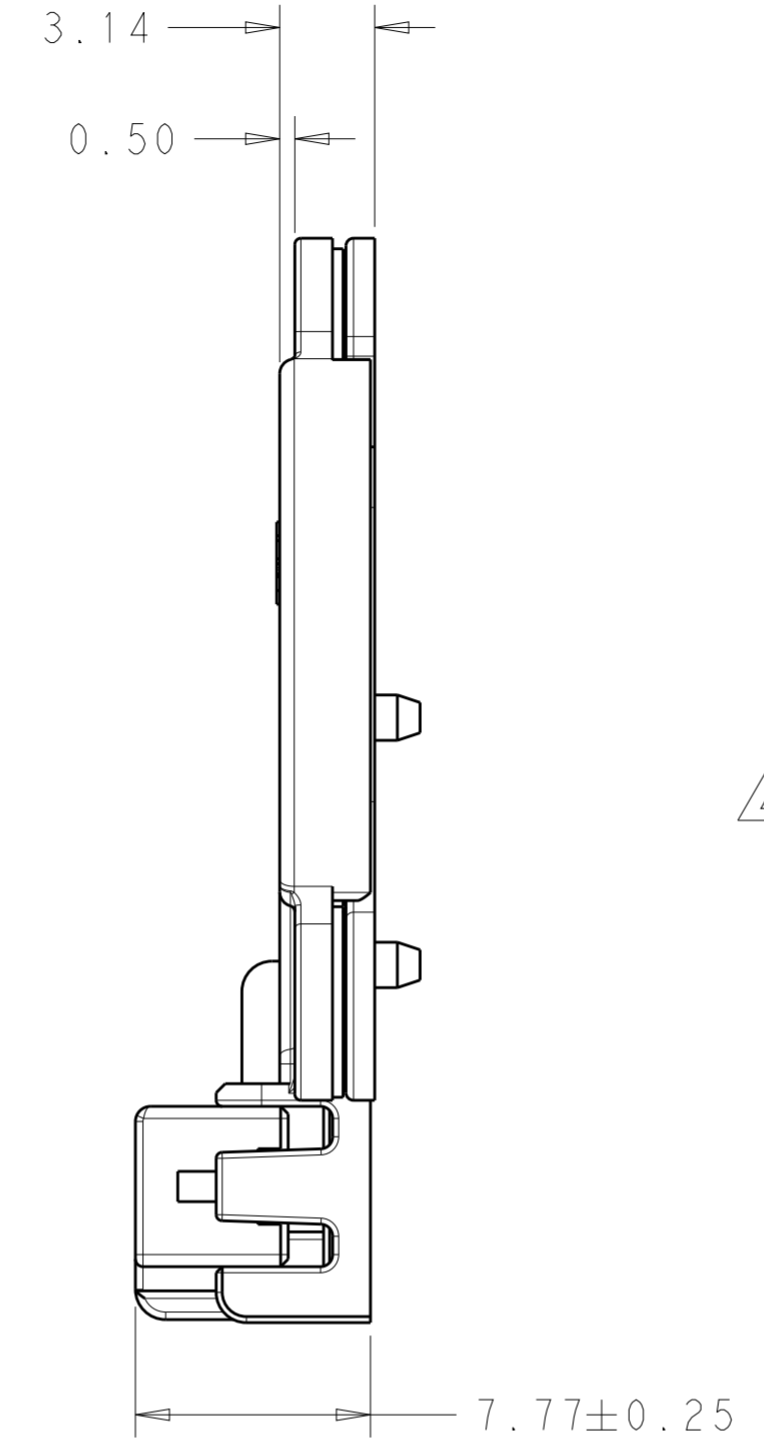
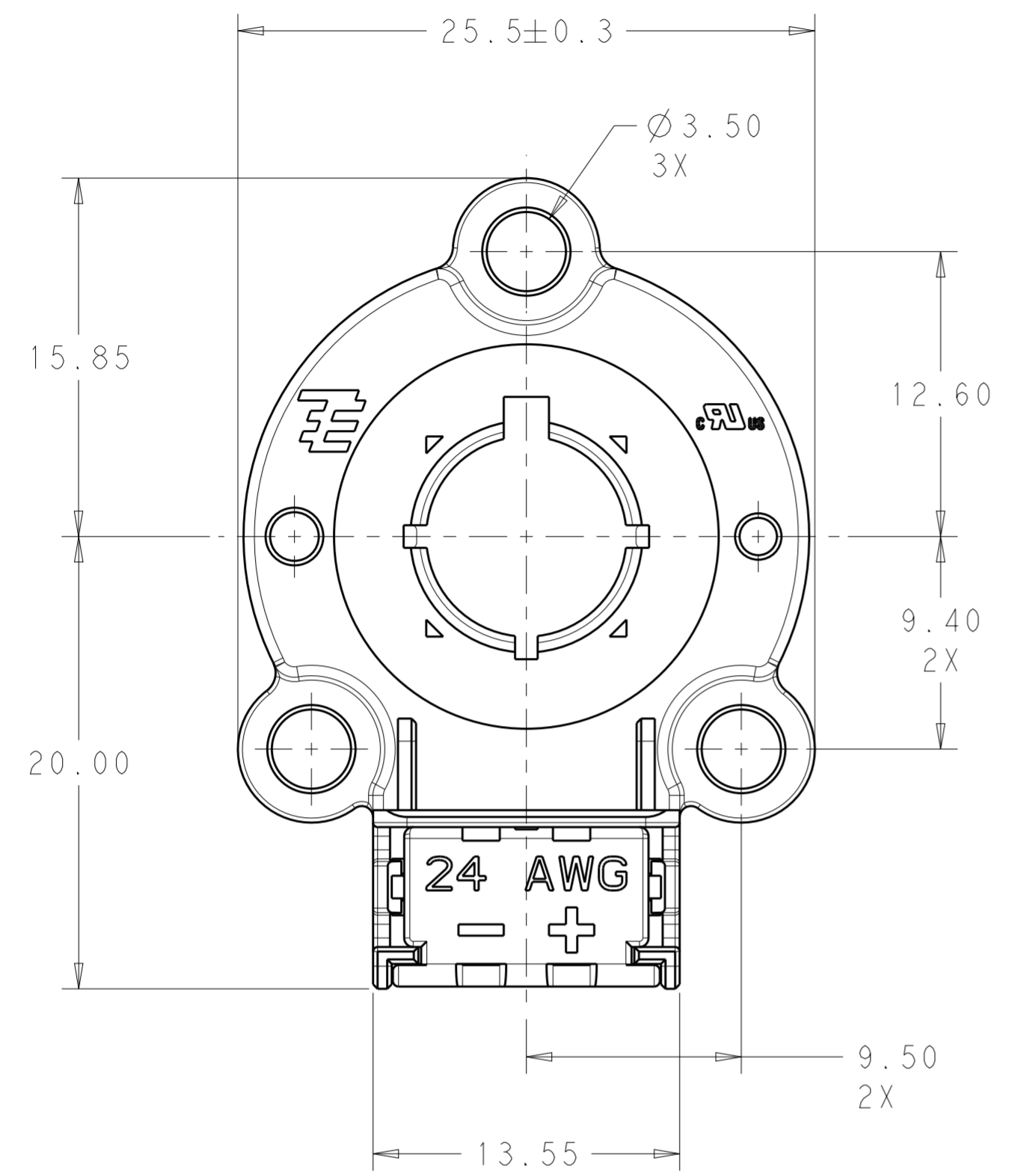

2154235-1 SHOWN

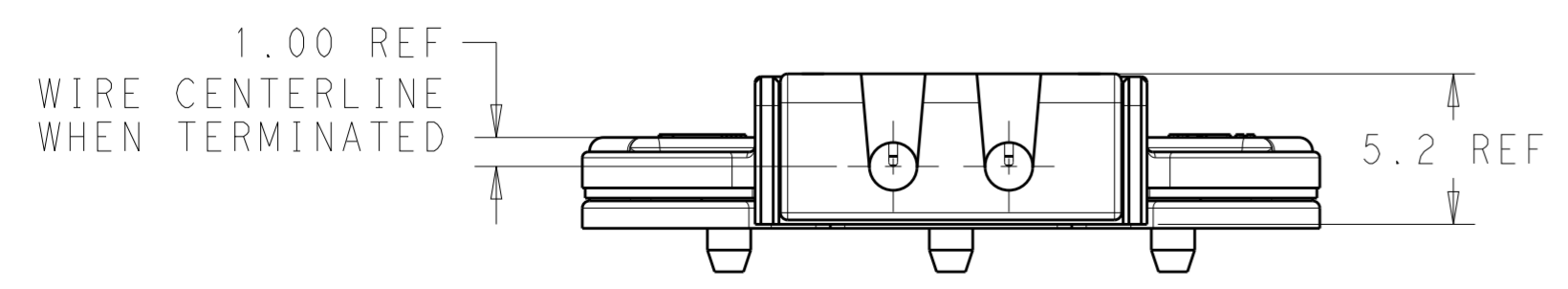

THIS DRAWING IS A CONTROLLED DOCUMENT.		DWN C. DAILY 14OCT2010	TE Connectivity	
DIMENSIONS: mm		CHK R. NARANG 14OCT2010		
TOLERANCES UNLESS OTHERWISE SPECIFIED:		APVD -	NAME ASSEMBLY, SOLDERLESS LED SOCKET, TYPE LS	
0 PLC ±		PRODUCT SPEC 108-2455	SIZE A200779	
1 PLC ±0.2		APPLICATION SPEC 114-13294	CAGE CODE C-2154235	
2 PLC ±0.15		WEIGHT -	DRAWING NO -	
3 PLC ±		Customer Drawing	RESTRICTED TO -	
4 PLC ±		SCALE 4:1	SHEET 2 OF 4	
ANGLES ±2°		REV A		
FINISH				

THIS DRAWING IS UNPUBLISHED. RELEASED FOR PUBLICATION 20
 © COPYRIGHT 20 BY - ALL RIGHTS RESERVED.

REVISIONS							
LOC	DIST	P	LTR	DESCRIPTION	DATE	DWN	APVD
-	-	-	-	SEE SHEET 1	-	-	-

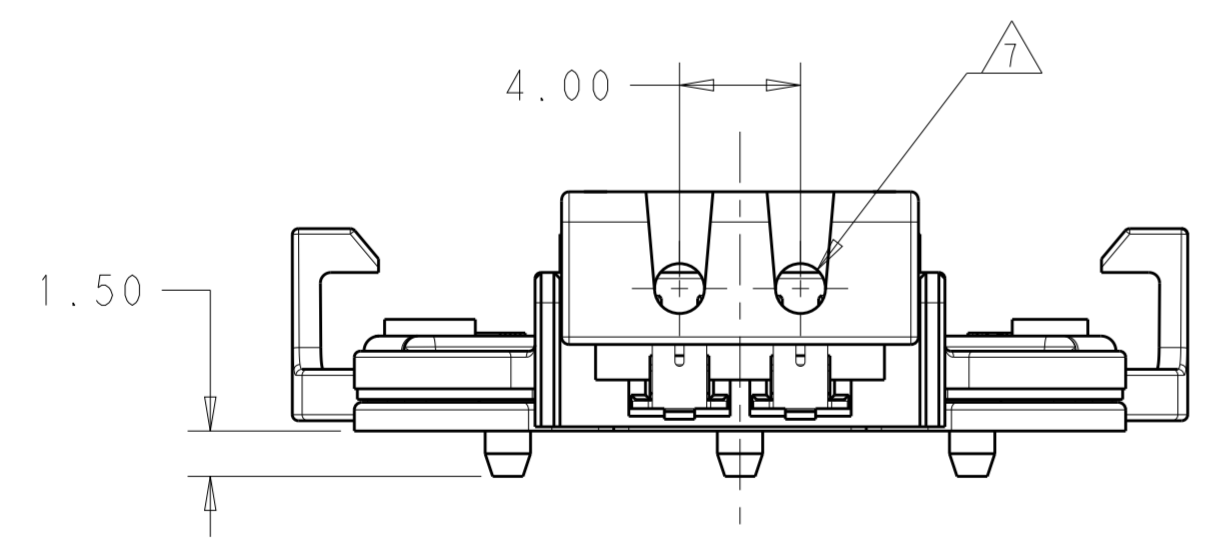
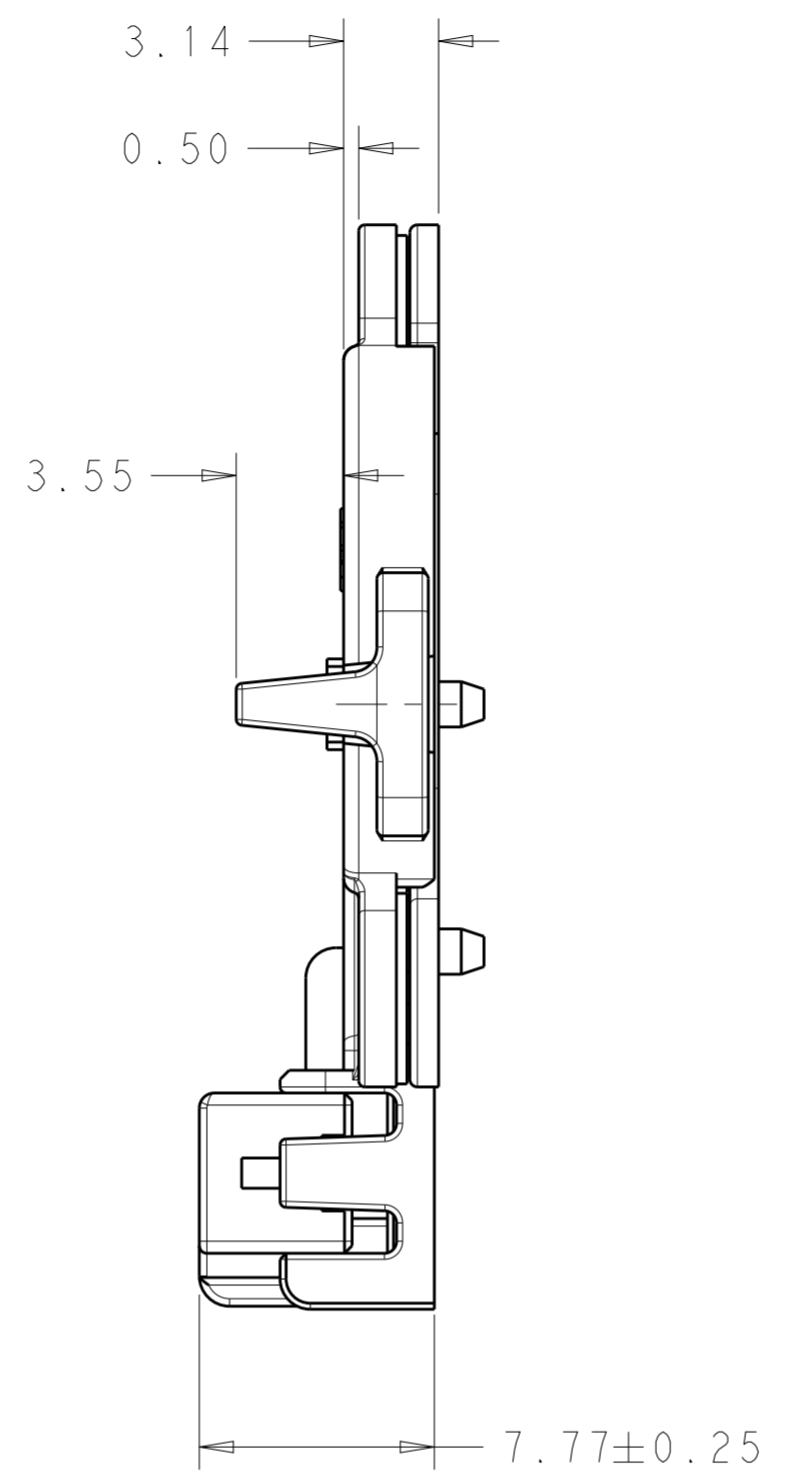
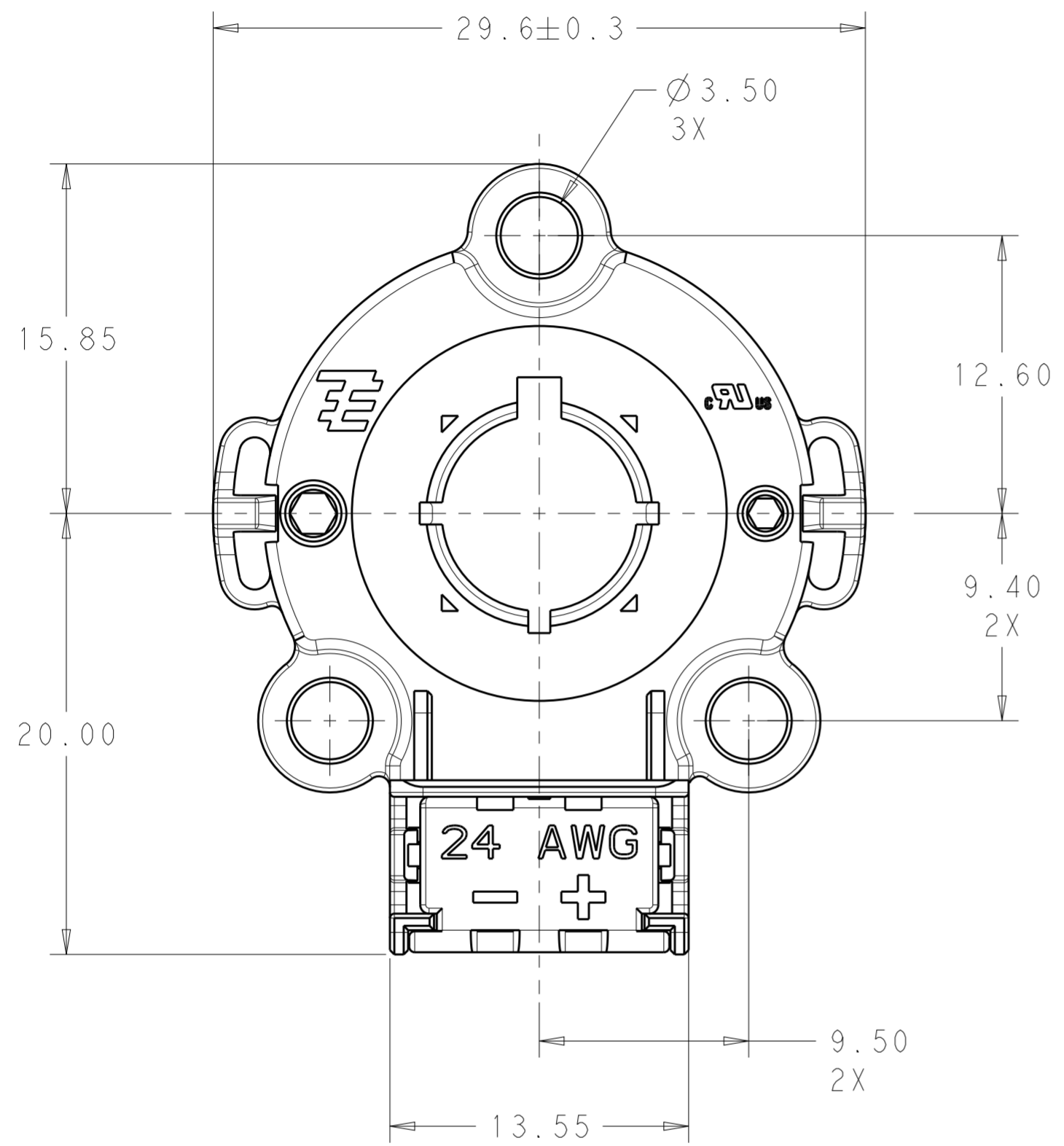

2154235-2 SHOWN

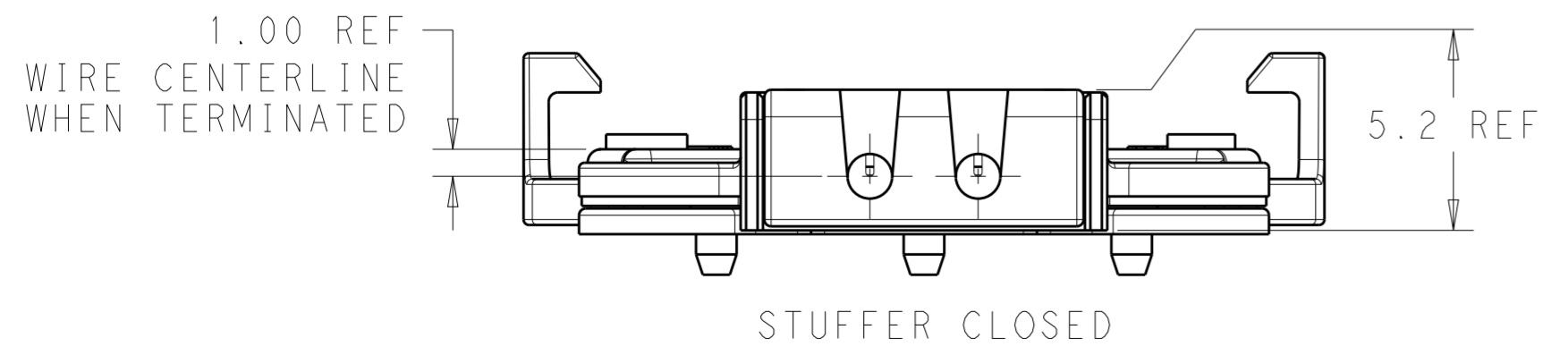

THIS DRAWING IS A CONTROLLED DOCUMENT.		DWN C. DAILY 14OCT2010	TE Connectivity	
		CHK R. NARANG 14OCT2010		
DIMENSIONS: mm		TOLERANCES UNLESS OTHERWISE SPECIFIED:		NAME ASSEMBLY, SOLDERLESS LED SOCKET, TYPE LS
<ul style="list-style-type: none"> 0 PLC ± 1 PLC ±0.2 2 PLC ±0.15 3 PLC ± 4 PLC ± ANGLES ±2° FINISH 		APVD -	PRODUCT SPEC 108-2455	SIZE A200779
MATERIAL 1		APPLICATION SPEC 114-13294	RESTRICTED TO -	DRAWING NO C-2154235
		WEIGHT -	SCALE 4:1	SHEET 3 OF 4
		Customer Drawing	REV A	

THIS DRAWING IS UNPUBLISHED. RELEASED FOR PUBLICATION 20
 © COPYRIGHT 20 BY - ALL RIGHTS RESERVED.

LOC		DIST		REVISIONS			
P	LTR	DESCRIPTION	DATE	DWN	APVD		
-	-	SEE SHEET 1	-	-	-		

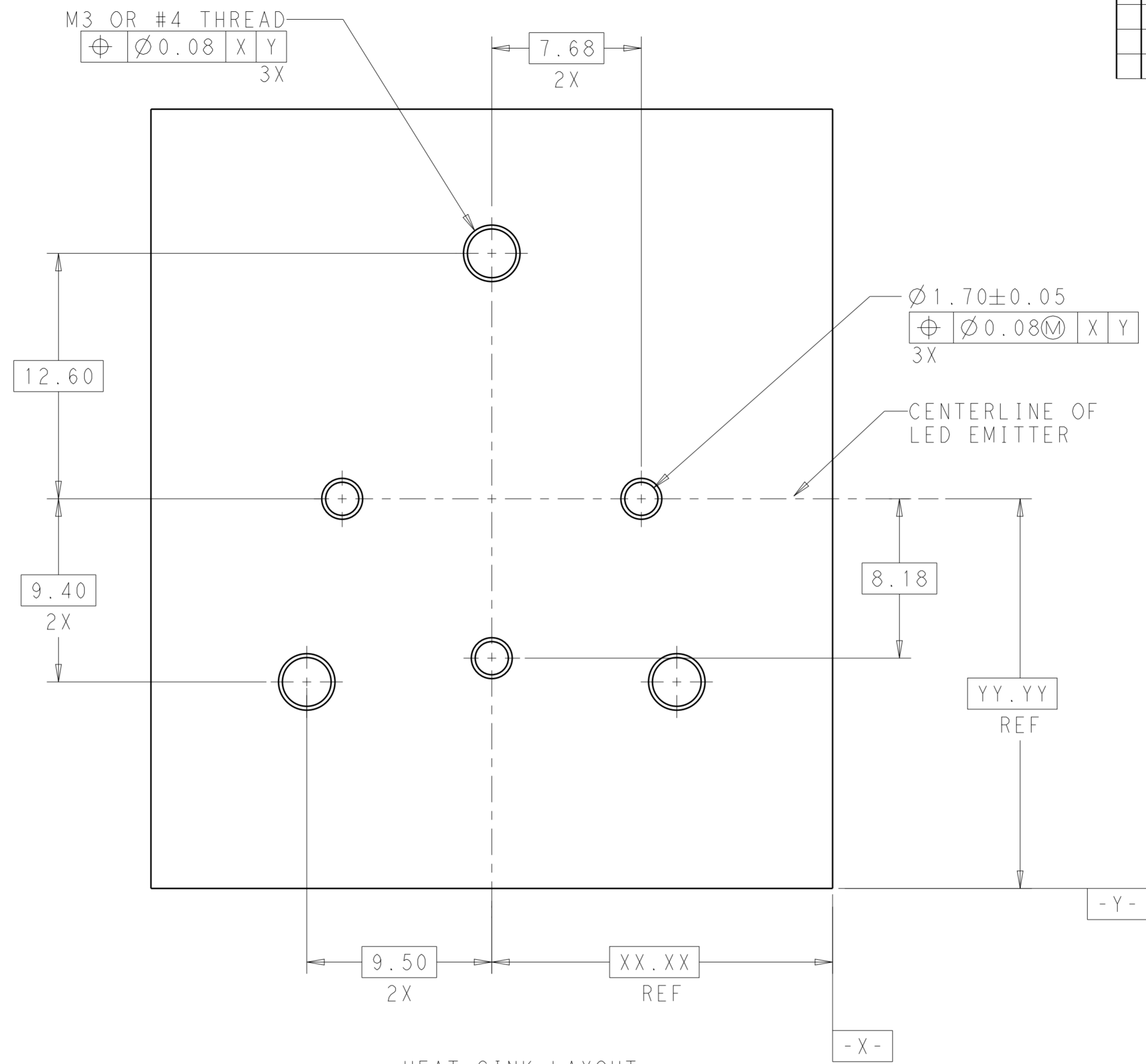

HEAT SINK LAYOUT
 SCALE 5:1

THIS DRAWING IS A CONTROLLED DOCUMENT.		DWN C. DAILY 14OCT2010	TE Connectivity	
		CHK R. NARANG 14OCT2010		
DIMENSIONS: mm		APVD -	NAME ASSEMBLY, SOLDERLESS LED SOCKET, TYPE LS	
TOLERANCES UNLESS OTHERWISE SPECIFIED:		PRODUCT SPEC 108-2455	SIZE A200779	
0 PLC ±		APPLICATION SPEC 114-13294	DRAWING NO C-2154235	
1 PLC ±0.2		WEIGHT -	RESTRICTED TO -	
2 PLC ±0.15		SCALE 4:1 SHEET 4 OF 4 REV A		
3 PLC ±		Customer Drawing		
4 PLC ±				
ANGLES ±2°				
FINISH				



Стандарт Электрон Связь

Мы молодая и активно развивающаяся компания в области поставок электронных компонентов. Мы поставляем электронные компоненты отечественного и импортного производства напрямую от производителей и с крупнейших складов мира.

Благодаря сотрудничеству с мировыми поставщиками мы осуществляем комплексные и плановые поставки широчайшего спектра электронных компонентов.

Собственная эффективная логистика и склад в обеспечивает надежную поставку продукции в точно указанные сроки по всей России.

Мы осуществляем техническую поддержку нашим клиентам и предпродажную проверку качества продукции. На все поставляемые продукты мы предоставляем гарантию .

Осуществляем поставки продукции под контролем ВП МО РФ на предприятия военно-промышленного комплекса России , а также работаем в рамках 275 ФЗ с открытием отдельных счетов в уполномоченном банке. Система менеджмента качества компании соответствует требованиям ГОСТ ISO 9001.

Минимальные сроки поставки, гибкие цены, неограниченный ассортимент и индивидуальный подход к клиентам являются основой для выстраивания долгосрочного и эффективного сотрудничества с предприятиями радиоэлектронной промышленности, предприятиями ВПК и научно-исследовательскими институтами России.

С нами вы становитесь еще успешнее!

Наши контакты:

Телефон: +7 812 627 14 35

Электронная почта: sales@st-electron.ru

Адрес: 198099, Санкт-Петербург,
Промышленная ул, дом № 19, литера Н,
помещение 100-Н Офис 331