

## RF power transistor, LdmoST plastic family N-channel enhancement-mode lateral MOSFETs

### Features

- Excellent thermal stability
- Common source configuration
- Broadband performances:  
P<sub>OUT</sub> = 6 W with 15 dB gain @ 870 MHz/13.6 V
- Plastic package
- ESD protection
- In compliance with the 2002/95/EC european directive

### Description

The PD85006-E is a common source N-channel, enhancement-mode lateral field-effect RF power transistor. It is designed for high gain, broadband commercial and industrial applications. It operates at 13.6 V in common source mode at frequencies of up to 1 GHz. PD85006-E boasts the excellent gain, linearity and reliability of ST's latest LDMOS technology mounted in the first true SMD plastic RF power package. PowerSO-10RF's superior linearity performance makes it an ideal solution for mobile radio applications.

The PowerSO-10 plastic package, designed to offer high reliability, is the first ST JEDEC approved, high power SMD package. It has been specially optimized for RF needs and offers excellent RF performance and ease of assembly. Mounting recommendations are available in [www.st.com/rf](http://www.st.com/rf) (search for AN1294).

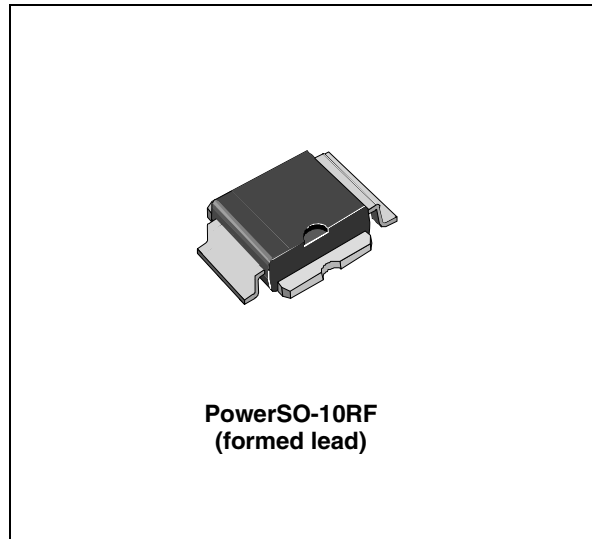

**Figure 1. Pin connections**

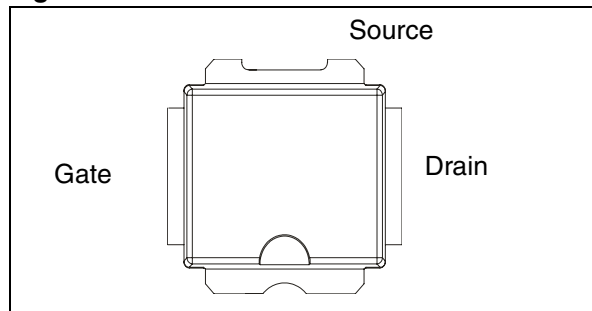

**Table 1. Device summary**

Order codes	Packages	Packaging
PD85006-E	PowerSO-10RF (formed lead)	Tube
PD85006TR-E	PowerSO-10RF (formed lead)	Tape and reel

# Contents

<b>1</b>	<b>Electrical data</b> .....	<b>3</b>
1.1	Maximum ratings .....	3
1.2	Thermal data .....	3
<b>2</b>	<b>Electrical characteristics</b> .....	<b>4</b>
2.1	Static .....	4
2.2	Dynamic .....	4
2.3	ESD protection characteristics .....	4
<b>3</b>	<b>Impedances</b> .....	<b>5</b>
<b>4</b>	<b>DC curves</b> .....	<b>6</b>
<b>5</b>	<b>RF curves</b> .....	<b>8</b>
<b>6</b>	<b>Schematic and bill of material</b> .....	<b>10</b>
<b>7</b>	<b>Package mechanical data</b> .....	<b>12</b>
<b>8</b>	<b>Revision history</b> .....	<b>16</b>

# 1 Electrical data

## 1.1 Maximum ratings

**Table 2. Absolute maximum ratings** ( $T_{CASE} = 25\text{ °C}$ )

Symbol	Parameter	Value	Unit
$V_{(BR)DSS}$	Drain-source voltage	40	V
$V_{GS}$	Gate-source voltage	-0.5 to +15	V
$I_D$	Drain current	2	A
$P_{DISS}$	Power dissipation (@ $T_C = 70\text{ °C}$ )	36.5	W
$T_J$	Max. operating junction temperature	165	°C
$T_{STG}$	Storage temperature	-65 to +150	°C

## 1.2 Thermal data

**Table 3. Thermal data**

Symbol	Parameter	Value	Unit
$R_{thJC}$	Junction - case thermal resistance	2.6	°C/W

## 2 Electrical characteristics

$T_{CASE} = +25\text{ °C}$

### 2.1 Static

**Table 4. Static**

Symbol	Test conditions		Min	Typ	Max	Unit	
$I_{DSS}$	$V_{GS} = 0V$	$V_{DS} = 25 V$	-		1	$\mu A$	
$I_{GSS}$	$V_{GS} = 5 V$	$V_{DS} = 0 V$			1	$\mu A$	
$V_{GS(Q)}$	$V_{DS} = 13.6 V$	$I_D = 200 mA$			4	V	
$V_{DS(ON)}$	$V_{GS} = 10 V$	$I_D = 0.25 A$			0.27	V	
$C_{ISS}$	$V_{GS} = 0V$	$V_{DS} = 13.6 V$		$f = 1 MHz$	16		pF
$C_{OSS}$	$V_{GS} = 0V$	$V_{DS} = 13.6 V$		$f = 1 MHz$	14		pF
$C_{RSS}$	$V_{GS} = 0V$	$V_{DS} = 13.6 V$		$f = 1 MHz$	1.1		pF

### 2.2 Dynamic

**Table 5. Dynamic**

Symbol	Test conditions	Min	Typ	Max	Unit
$P_{OUT}$	$V_{DD} = 13.6 V, I_{DQ} = 200 mA, P_{IN} = 0.1 W, f = 870 MHz$	5	6	-	W
$G_P$	$V_{DD} = 13.6 V, I_{DQ} = 200 mA, P_{OUT} = 5 W, f = 870 MHz$	15	17		dB
$h_D$	$V_{DD} = 13.6 V, I_{DQ} = 200 mA, P_{OUT} = 5 W, f = 870 MHz$	55	63		%
Load mismatch	$V_{DD} = 13.6 V, I_{DQ} = 200 mA, P_{OUT} = 5 W, f = 870 MHz$ All phase angles	20:1			VSWR

### 2.3 ESD protection characteristics

**Table 6. ESD protection characteristics**

Test conditions	Class
Human body model	2
Machine model	M3

### 3 Impedances

Figure 2. Impedances

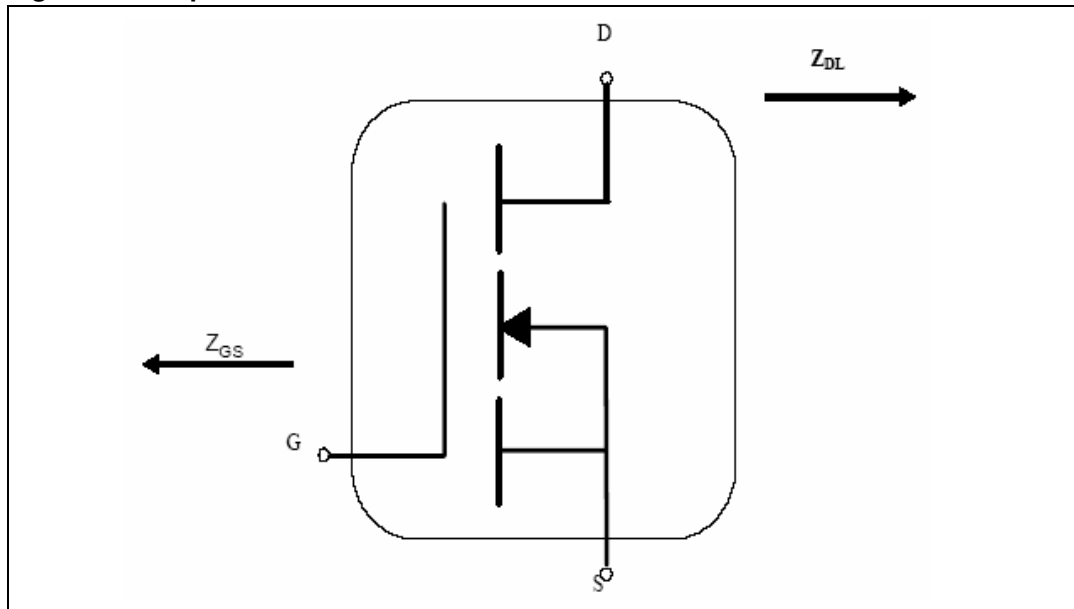
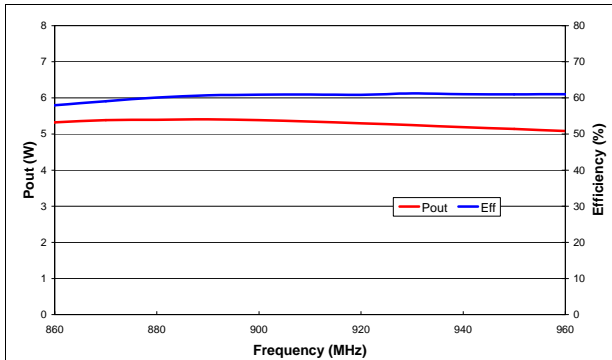

Table 7. Broadband impedances

F(MHz)	$Z_{GS}$	$Z_{DL}$
860	2.66+ j 4.28	6.23+ j 5.71
880	2.81+ j 4.35	6.46+ j 6.20
900	2.88+ j 4.34	6.73 + j 6.66
920	2.87+ j 4.25	7.06+ j 7.06
940	2.68+ j 4.20	7.40+ j 7.45
960	2.39+ j 4.20	7.80+ j 7.75

# 4 DC curves

**Figure 3. Output power and efficiency vs. frequency**  
13.6 V / 200 mA / Pin = 21 dBm



**Figure 4. Gain vs. frequency 13.6 V / 200 mA**

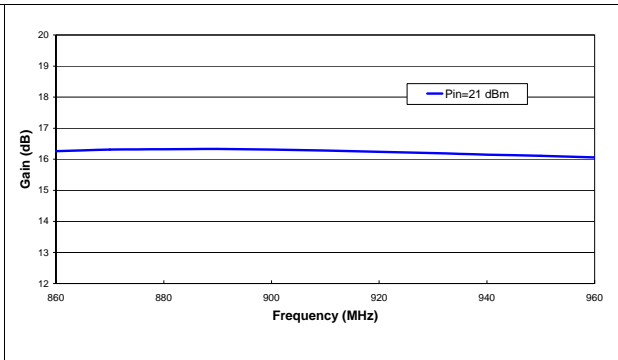

**Figure 5. Input return loss vs. frequency**  
13.6 V / 200 mA

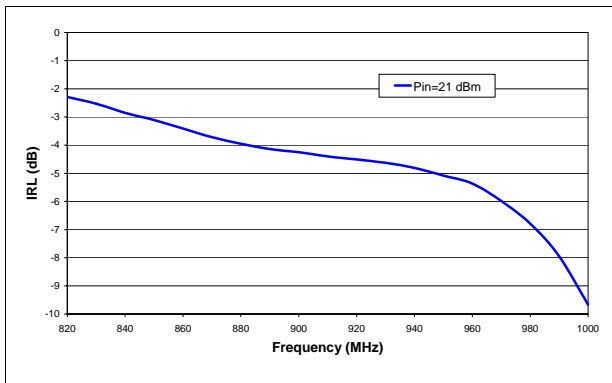

**Figure 6. Gain vs. pout 13.6 V / 200 mA**

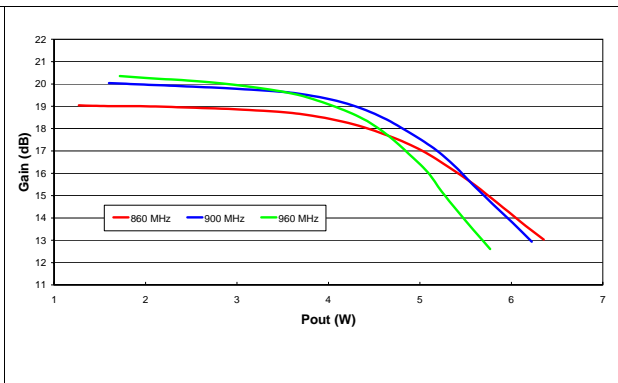

**Figure 7. Id vs. pin 13.6 V / 200 mA**

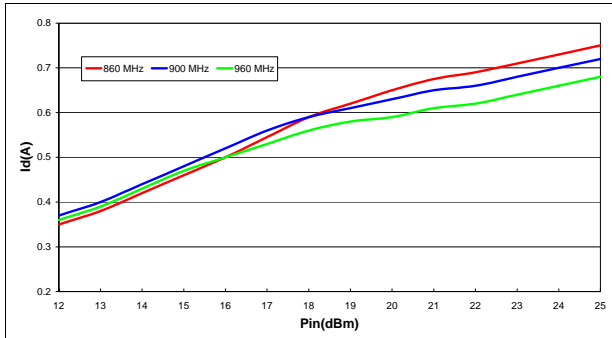

**Figure 8. Pout vs. pin 13.6 V / 200 mA**

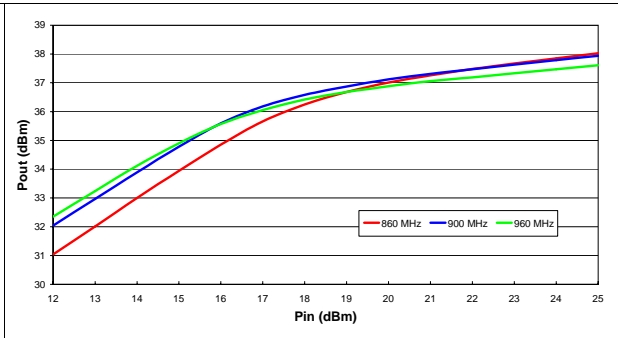

Figure 9. DC output characteristics

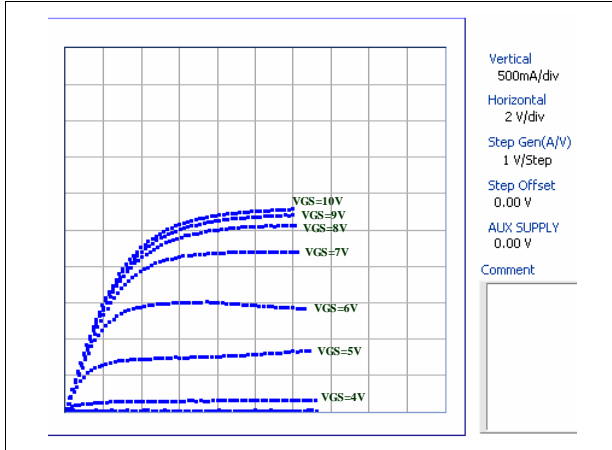

Figure 10.  $I_D$  vs.  $V_{GS}$

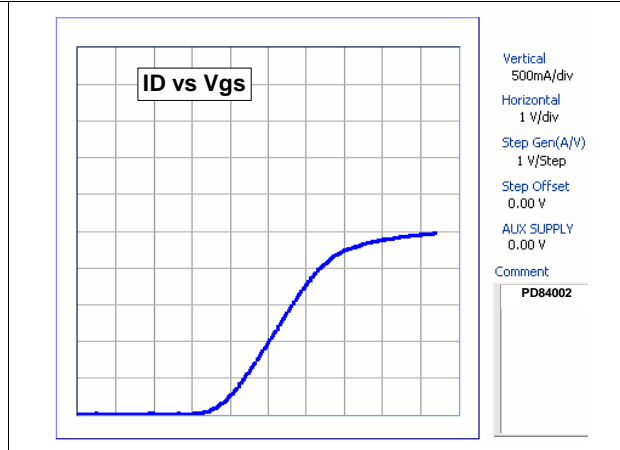
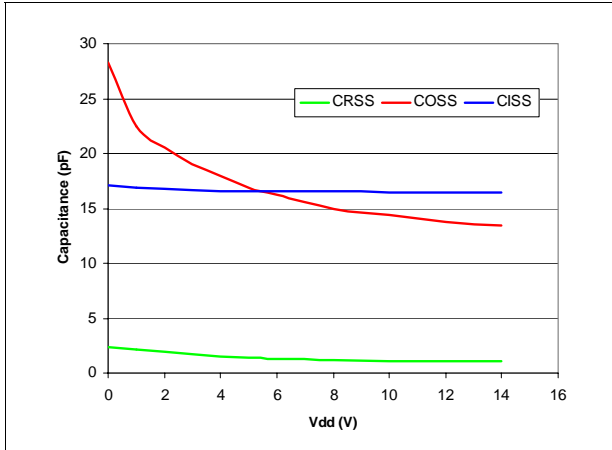
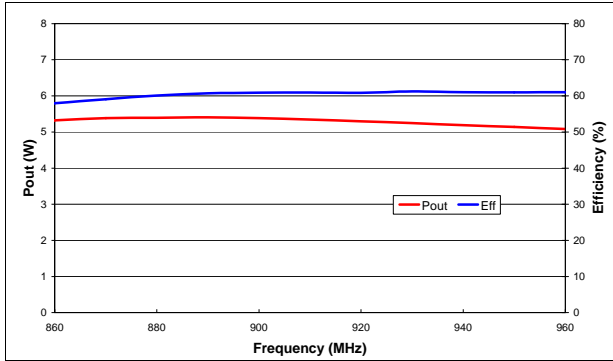

Figure 11. Capacitances vs. drain voltage



# 5 RF curves

**Figure 12. Output power and efficiency vs. frequency**  
 13.6 V / 200 mA / Pin = 21 dBm



**Figure 13. Gain vs. frequency 13.6 V / 200 mA**

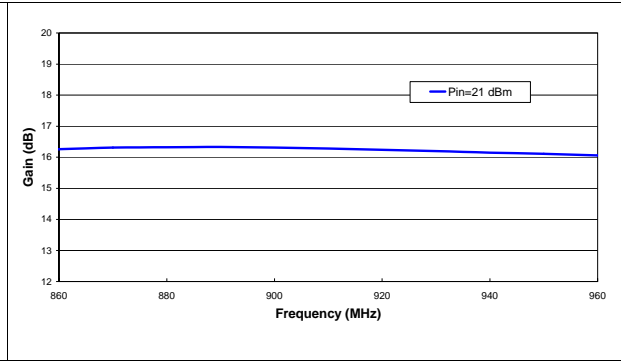

**Figure 14. Input return loss vs. frequency**  
 13.6 V / 200 mA

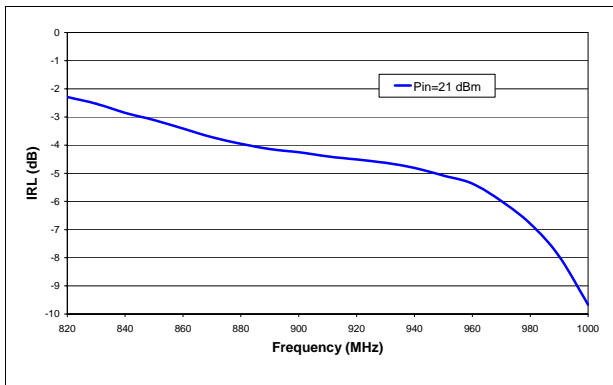

**Figure 15. Gain vs. pout 13.6 V / 200 mA**

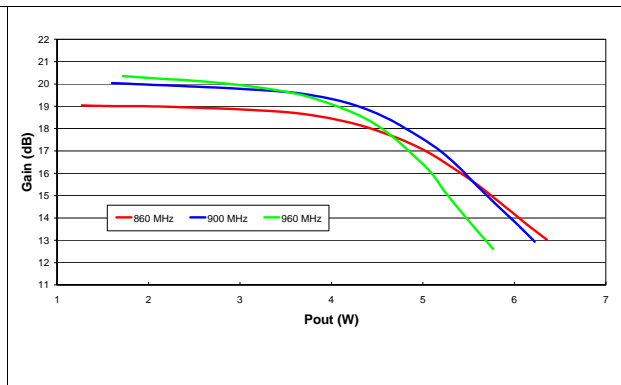

**Figure 16. Id vs. pin 13.6 V / 200 mA**

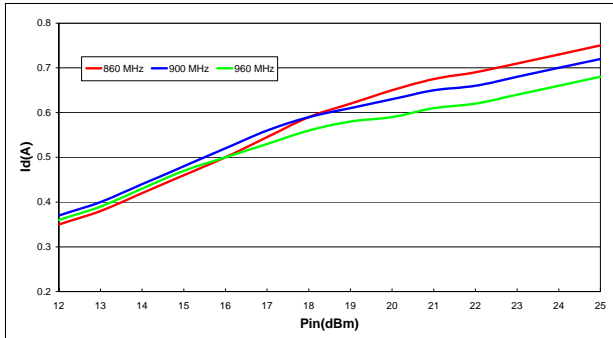

**Figure 17. Pout vs. pin 13.6 V / 200 mA**

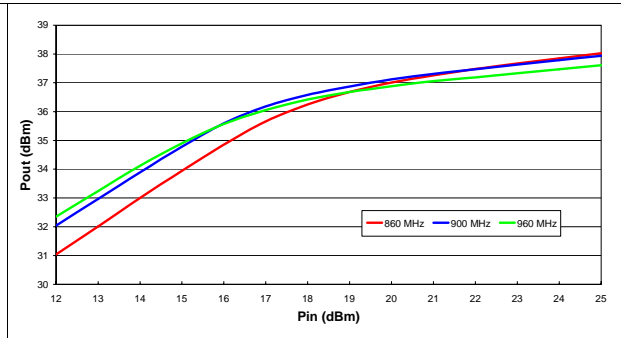
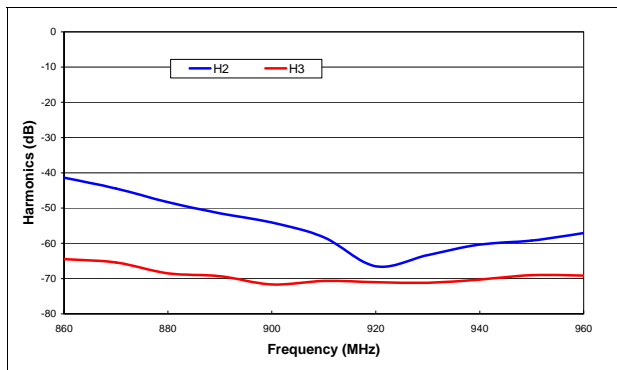



Figure 18. Harmonics vs. frequency  
13.6 V / 200 mA



## 6 Schematic and bill of material

Figure 19. Schematic and bill of material

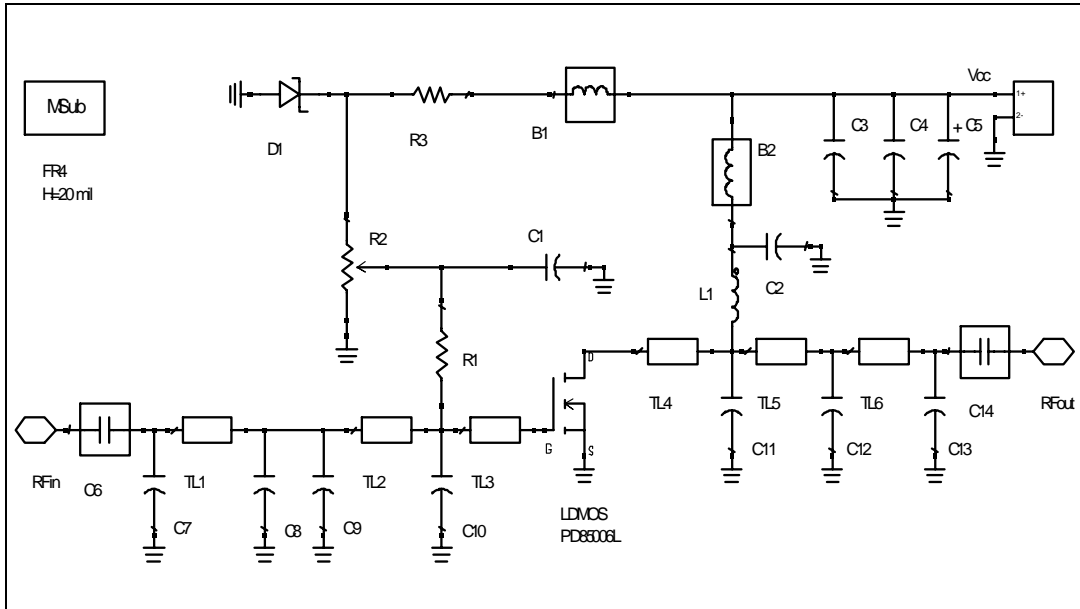

Table 8. Components part list

Component ID	Description	Value	Case size	Manufacturer	Part code
B1	Ferrite Bead			Panasonic	EXCELDR35C
B2	Ferrite Bead			Panasonic	EXCELDR35C
C1, C2	Capacitor	120 pF	0603	Murata	GRM39-C0G121J50D500
C3	Capacitor	1 nF	0603	Murata	GRM39-X7R102K50C560
C4	Capacitor	10 nF	0603	Murata	GRM39-X7R103K50C560
C5	Capacitor	10 $\mu$ F	SMT	Panasonic	EEVHB1V100P
C6, C14	Capacitor	39 pF	0603	Murata	GRM39-C0G390J50D500
C7	Capacitor	3.3 pF	0603	Murata	GRM39-C0G3R3C50Z500
C8	Capacitor	2.7 pF	0603	Murata	GRM39-C0G2R7C50Z500
C9	Capacitor	12 pF	0603	Murata	GRM39-C0G120J50D500
C10	Capacitor	22 pF	0603	Murata	GRM39-C0G220J50D500
C11	Capacitor	8.2 pF	0603	Murata	GRM39-C0G8R2D50Z500
C12	Capacitor	6,8 pF	0603	Murata	GRM39-C0G6R8D50Z500
C13	Capacitor	3.9 pF	0603	Murata	GRM39-C0G3R9C50Z500
D1	Zener Diode	5.1 V	SOD110	Philips	BZX284C5V1
L1	Inductor	12.55 nH		Coilcraft	1606-10
R1	Resistor	510 $\Omega$	0603	Tyco electronics	

**Table 8. Components part list (continued)**

Component ID	Description	Value	Case size	Manufacturer	Part code
R2	Potentiometer	10 kΩ		Bourns electronics	3214W-1-103E
R3	Resistor	1 k	0603	Tyco electronics	01623440-1
TL1	Transmission line	W=0.92mm	L = 12.1 mm		
TL2	Transmission line	W=0.92mm	L = 3.2 mm		
TL3	Transmission line	W=0.92mm	L = 3.0 mm		
TL4	Transmission line	W= 0.92 mm	L = 3.2 mm		
TL5	Transmission line	W= 0.92 mm	L = 3.9 mm		
TL6	Transmission line	W=0.92mm	L=11.0 mm		
RF in, RF out	SMA-CONN	50 Ω	60 mils	Johnson	142-0701-801
PD85006	LDMOS			STMicroelectronics	PD85006
Board	FR-4 THk=0.020" 2OZ Cu both sides				

## 7 Package mechanical data

In order to meet environmental requirements, ST offers these devices in different grades of ECOPACK® packages, depending on their level of environmental compliance. ECOPACK® specifications, grade definitions and product status are available at: [www.st.com](http://www.st.com). ECOPACK® is an ST trademark.

**Table 9. PowerSO-10RF formed lead (gull wing) mechanical data**

Dim.	mm			Inch		
	Min	Typ	Max	Min	Typ	Max
A1	0	0.05	0.1	0.	0.0019	0.0038
A2	3.4	3.5	3.6	0.134	0.137	0.142
A3	1.2	1.3	1.4	0.046	0.05	0.054
A4	0.15	0.2	0.25	0.005	0.007	0.009
a		0.2			0.007	
b	5.4	5.53	5.65	0.212	0.217	0.221
c	0.23	0.27	0.32	0.008	0.01	0.012
D	9.4	9.5	9.6	0.370	0.374	0.377
D1	7.4	7.5	7.6	0.290	0.295	0.298
E	13.85	14.1	14.35	0.544	0.555	0.565
E1	9.3	9.4	9.5	0.365	0.37	0.375
E2	7.3	7.4	7.5	0.286	0.292	0.294
E3	5.9	6.1	6.3	0.231	0.24	0.247
F		0.5			0.019	
G		1.2			0.047	
L	0.8	1	1.1	0.030	0.039	0.042
R1			0.25			0.01
R2		0.8			0.031	
T	2 deg	5 deg	8 deg	2 deg	5 deg	8 deg
T1		6 deg			6 deg	
T2		10 deg			10 deg	

*Note: Resin protrusions not included (max value: 0.15 mm per side)*

Figure 20. Package dimensions

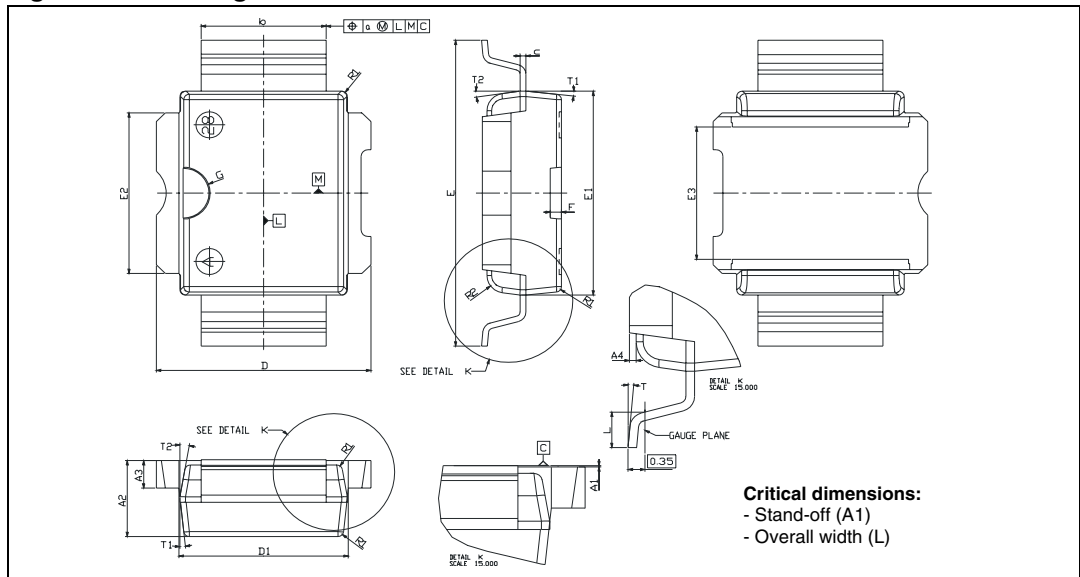

Figure 21. Tube information

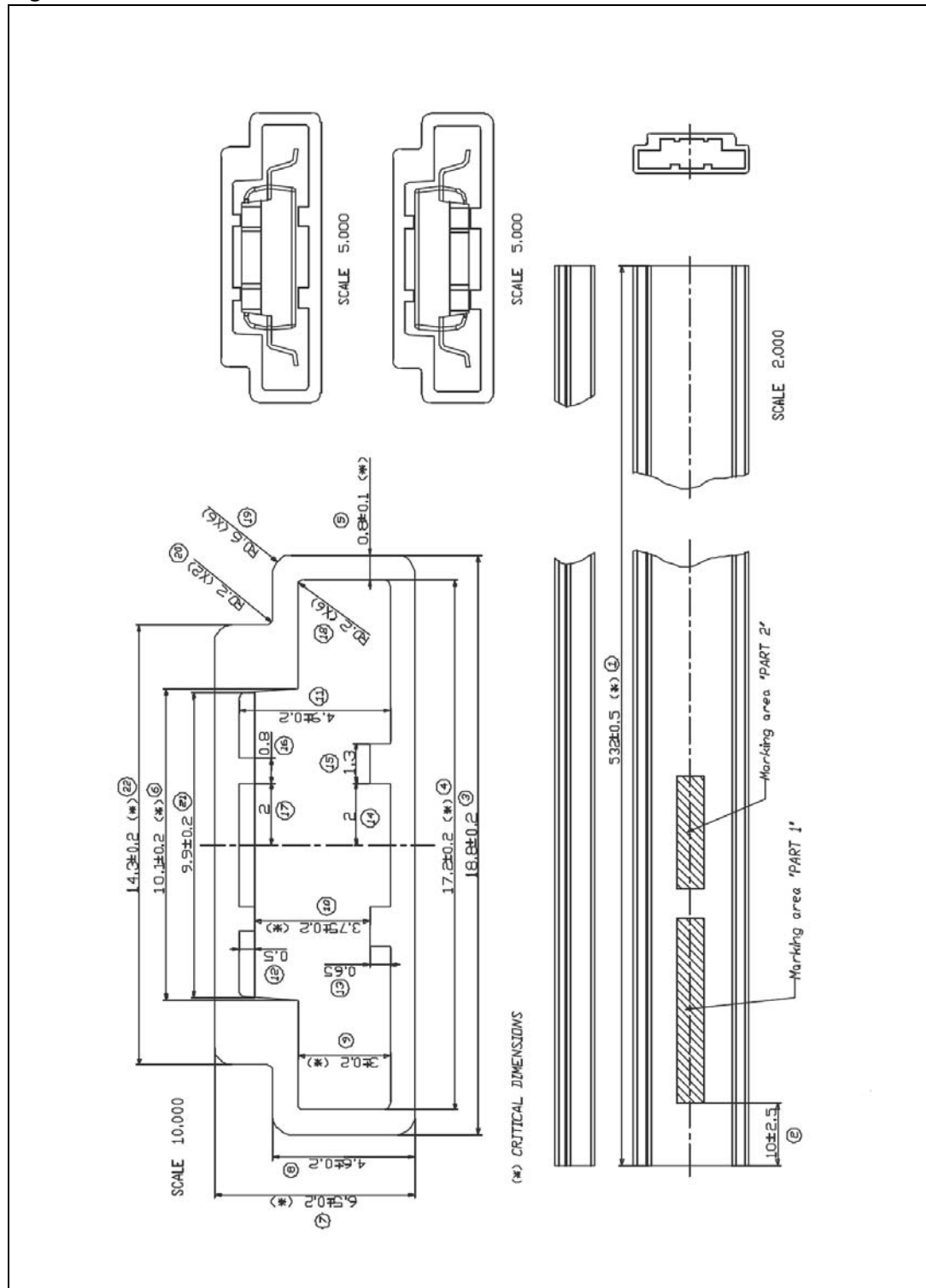
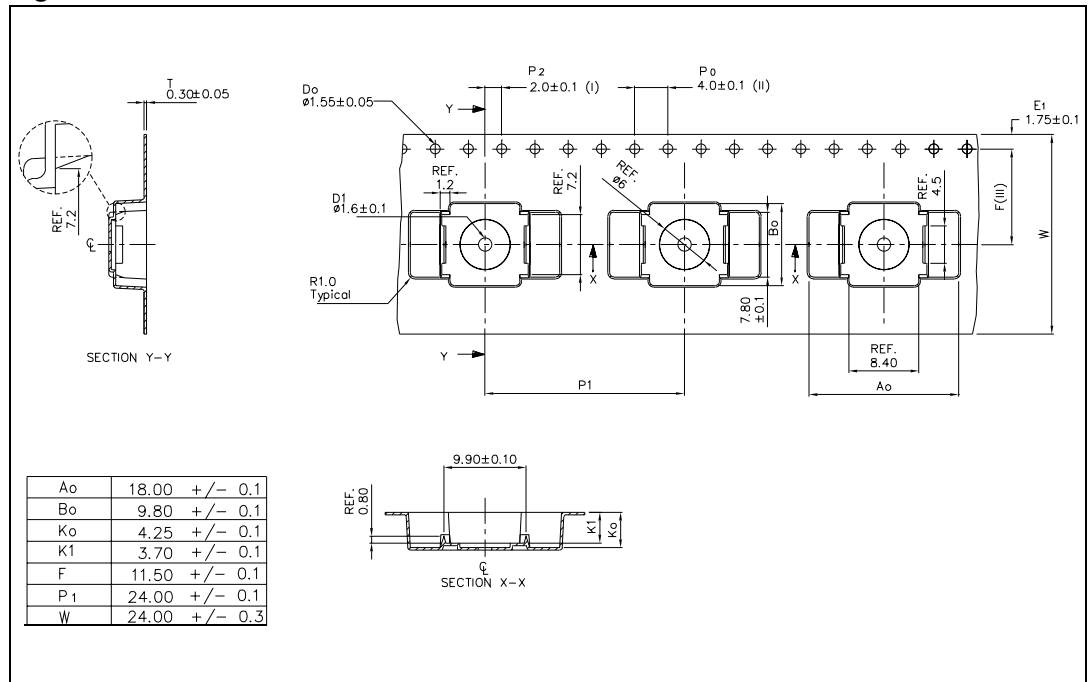

Figure 22. Reel information



## 8 Revision history

**Table 10. Document revision history**

Date	Revision	Changes
03-Sep-2009	1	Initial release.
29-Oct-2009	2	Updated figure on cover page.
04-Aug-2010	3	Added device shipped in tape and reel, see <a href="#">Table 1: Device summary</a> .



**Please Read Carefully:**

Information in this document is provided solely in connection with ST products. STMicroelectronics NV and its subsidiaries ("ST") reserve the right to make changes, corrections, modifications or improvements, to this document, and the products and services described herein at any time, without notice.

All ST products are sold pursuant to ST's terms and conditions of sale.

Purchasers are solely responsible for the choice, selection and use of the ST products and services described herein, and ST assumes no liability whatsoever relating to the choice, selection or use of the ST products and services described herein.

No license, express or implied, by estoppel or otherwise, to any intellectual property rights is granted under this document. If any part of this document refers to any third party products or services it shall not be deemed a license grant by ST for the use of such third party products or services, or any intellectual property contained therein or considered as a warranty covering the use in any manner whatsoever of such third party products or services or any intellectual property contained therein.

**UNLESS OTHERWISE SET FORTH IN ST'S TERMS AND CONDITIONS OF SALE ST DISCLAIMS ANY EXPRESS OR IMPLIED WARRANTY WITH RESPECT TO THE USE AND/OR SALE OF ST PRODUCTS INCLUDING WITHOUT LIMITATION IMPLIED WARRANTIES OF MERCHANTABILITY, FITNESS FOR A PARTICULAR PURPOSE (AND THEIR EQUIVALENTS UNDER THE LAWS OF ANY JURISDICTION), OR INFRINGEMENT OF ANY PATENT, COPYRIGHT OR OTHER INTELLECTUAL PROPERTY RIGHT.**

**UNLESS EXPRESSLY APPROVED IN WRITING BY AN AUTHORIZED ST REPRESENTATIVE, ST PRODUCTS ARE NOT RECOMMENDED, AUTHORIZED OR WARRANTED FOR USE IN MILITARY, AIR CRAFT, SPACE, LIFE SAVING, OR LIFE SUSTAINING APPLICATIONS, NOR IN PRODUCTS OR SYSTEMS WHERE FAILURE OR MALFUNCTION MAY RESULT IN PERSONAL INJURY, DEATH, OR SEVERE PROPERTY OR ENVIRONMENTAL DAMAGE. ST PRODUCTS WHICH ARE NOT SPECIFIED AS "AUTOMOTIVE GRADE" MAY ONLY BE USED IN AUTOMOTIVE APPLICATIONS AT USER'S OWN RISK.**

Resale of ST products with provisions different from the statements and/or technical features set forth in this document shall immediately void any warranty granted by ST for the ST product or service described herein and shall not create or extend in any manner whatsoever, any liability of ST.

ST and the ST logo are trademarks or registered trademarks of ST in various countries.

Information in this document supersedes and replaces all information previously supplied.

The ST logo is a registered trademark of STMicroelectronics. All other names are the property of their respective owners.

© 2010 STMicroelectronics - All rights reserved

STMicroelectronics group of companies

Australia - Belgium - Brazil - Canada - China - Czech Republic - Finland - France - Germany - Hong Kong - India - Israel - Italy - Japan - Malaysia - Malta - Morocco - Philippines - Singapore - Spain - Sweden - Switzerland - United Kingdom - United States of America

[www.st.com](http://www.st.com)





## Стандарт Электрон Связь

Мы молодая и активно развивающаяся компания в области поставок электронных компонентов. Мы поставляем электронные компоненты отечественного и импортного производства напрямую от производителей и с крупнейших складов мира.

Благодаря сотрудничеству с мировыми поставщиками мы осуществляем комплексные и плановые поставки широчайшего спектра электронных компонентов.

Собственная эффективная логистика и склад в обеспечивает надежную поставку продукции в точно указанные сроки по всей России.

Мы осуществляем техническую поддержку нашим клиентам и предпродажную проверку качества продукции. На все поставляемые продукты мы предоставляем гарантию .

Осуществляем поставки продукции под контролем ВП МО РФ на предприятия военно-промышленного комплекса России , а также работаем в рамках 275 ФЗ с открытием отдельных счетов в уполномоченном банке. Система менеджмента качества компании соответствует требованиям ГОСТ ISO 9001.

Минимальные сроки поставки, гибкие цены, неограниченный ассортимент и индивидуальный подход к клиентам являются основой для выстраивания долгосрочного и эффективного сотрудничества с предприятиями радиоэлектронной промышленности, предприятиями ВПК и научно-исследовательскими институтами России.

С нами вы становитесь еще успешнее!

### Наши контакты:

**Телефон:** +7 812 627 14 35

**Электронная почта:** [sales@st-electron.ru](mailto:sales@st-electron.ru)

**Адрес:** 198099, Санкт-Петербург,  
Промышленная ул, дом № 19, литера Н,  
помещение 100-Н Офис 331