

## General Description

The MAX11166 evaluation system (EV system) includes a mother board and daughter board to evaluate the MAX11166 16-bit ADC. The EV system includes a simple graphical user interface (GUI) for exercising the features of the IC. This GUI is compatible with Windows XP®, Windows Vista®, and Windows® 7. The EV system GUI allows different sample sizes, adjustable sampling rates, internal or external reference options, and graphing software that includes the following representations of the sampled signals: time domain, frequency domain, histogram, and single conversion.

The EV system is made up of the MAXPRECADCMB mother board with an on-board Altera FPGA and the daughter board for evaluating the IC. The mother board plugs into the PC through a high-speed USB link to send SPI commands through the GUI. The mother board accepts a 5V supply. The daughter board accepts  $\pm 15V$  supplies.

The daughter board comes installed with a MAX11166ETC+ in a 12-pin TDFN-EP package.

## Features

- Windows XP-, Windows Vista-, and Windows 7-Compatible Software
- High-Speed USB Interface
- Various Sample Sizes and Sample Rates
- Time Domain, Frequency Domain, and Histogram Plotting
- Collects Up to 1 Mega Samples
- Frequency, RMS, MIN, MAX, and Average DC Calculations
- On-Board Voltage Reference
- 40MHz SPI Interface
- RoHS Compliant
- Proven PCB Layout
- Fully Assembled and Tested

*Ordering Information appears at end of data sheet.*

## MAX11166 EV System Block Diagram

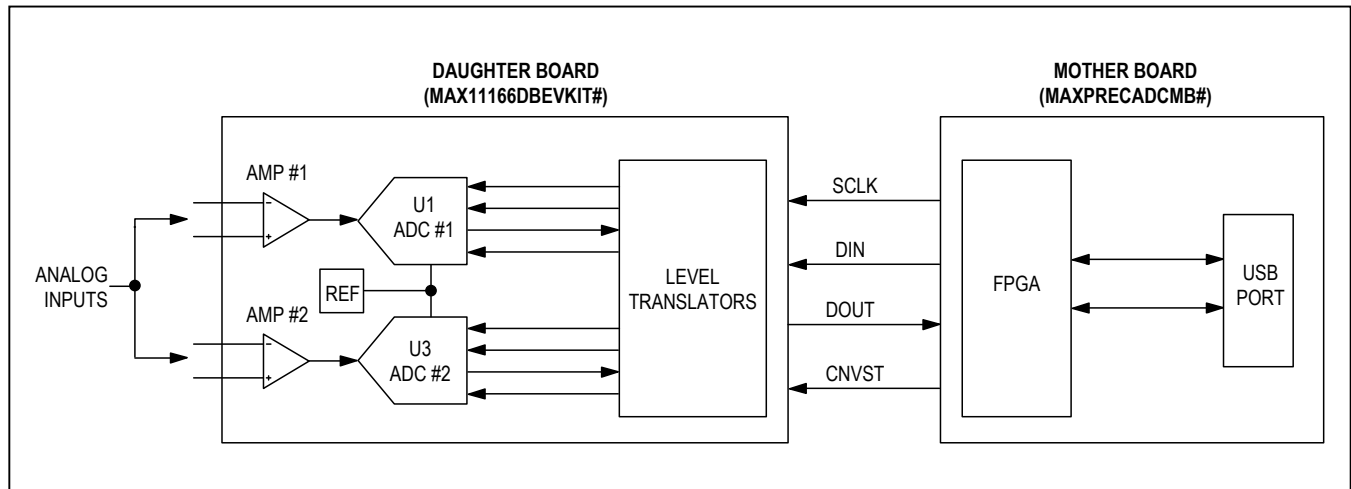

Windows, Windows XP, and Windows Vista are registered trademarks and registered service marks of Microsoft Corporation.

**MAX11166 EV System Files**

FILE	DESCRIPTION
INSTALL.EXE	Installs the EV system files on your computer
MAX11166.EXE	Application program
SLSUSB.DLL	Software library file
SLSUSB.INF	USB device driver file
SLSUSB.SYS	USB device driver file
USB_Driver_Help_200.PDF	USB driver installation file

**Quick Start**

**Required Equipment**

- MAX11166 daughter board (included with the EV system)
- MAXPRECADCMB (included with EV system)
- ±15V DC power supply
- +5V DC power supply
- Function generator
- Digital voltmeters (DVMs)
- Windows XP, Windows Vista, or Windows 7 PC with a spare USB port

**Note:** In the following sections, software-related items are identified by bolding. Text in **bold** refers to items directly from the EV system software. Text in **bold and underlined** refers to items from the Windows operating system.

**Procedure**

The EV system is fully assembled and tested. Follow the steps below to verify board operation. **Caution: Do not turn on the power supply until all connections are completed.**

- 1) Uncompress the 11166Rxx.ZIP file in a temporary folder.
- 2) Install the EV system software on your computer by running the **INSTALL.EXE** program inside the temporary folder. The program files are copied and icons are created in the Windows **Start | Programs** menu.
- 3) Carefully connect the MAXPRECADCMB (mother board) with the daughter board by aligning the mother board's J1 connector with the daughter board's J1 connector. Gently press them together.
- 4) Verify that all jumpers are in their default positions, as shown in Table 1 and Table 2.

- 5) Connect the USB cable from the PC to the mother board.
- 6) Connect the positive terminal of the +5V power supply to the VIN connector on the mother board. Connect the negative terminal of the same power supply to the DGND connector on the board. Connect the +15V to the EXT\_VCC connector on the daughter board, and connect the -15V to the EXT\_VEE connector on the daughter board. Connect the ground of the same power supply to the GND connector on the daughter board.
- 7) Set the signal source to generate a 1kHz, 1V<sub>p-p</sub> sinusoidal wave with 0V offset.
- 8) Connect the positive terminal of the signal generator to the AIN+ connector on the daughter board. Connect the negative terminal of the signal generator to the GND connector.
- 9) Turn on the power supplies.
- 10) Connect the USB cable from the PC to the mother board. A **New Hardware Found** window pops up when installing the USB driver for the first time. If you do not see a window similar to the one described above after 30s, remove the USB cable from the board and reconnect it. Administrator privileges are required to install the USB device driver on Windows.
- 11) Follow the directions of the **Add New Hardware Wizard** to install the USB device driver. Choose the **Search for the best driver for your device** option. Specify the location of the device driver to be **C:\Program Files\MAX11166** (default installation directory) using the **Browse** button. During device driver installation, Windows may show a warning message indicating that the device driver does not contain a digital signature. This is not an error condition and it is safe to proceed with installation.

- 12) Turn on the function generator.
- 13) Start the EV system software by opening its icon in the **Start | Programs** menu. The EV system software device selection window appears, as shown in Figure 1.
- 14) The main windows should indicate **Hardware Connected** at the bottom-left corner.
- 15) Press the **Start Conversion** button.
- 16) Verify **Frequency** of approximately 1000Hz.

### Detailed Description of Software

The main window of the evaluation software (shown in Figure 1) configures the ADCs and displays the data using the four tab sheets: **Time Domain**, **Frequency Domain**, **Histogram**, and **Single Conversion**. In addition, the sampled data can be saved to a file.

ADC #1 is designated as U1 and ADC #2 is designated as U3 in the schematic.

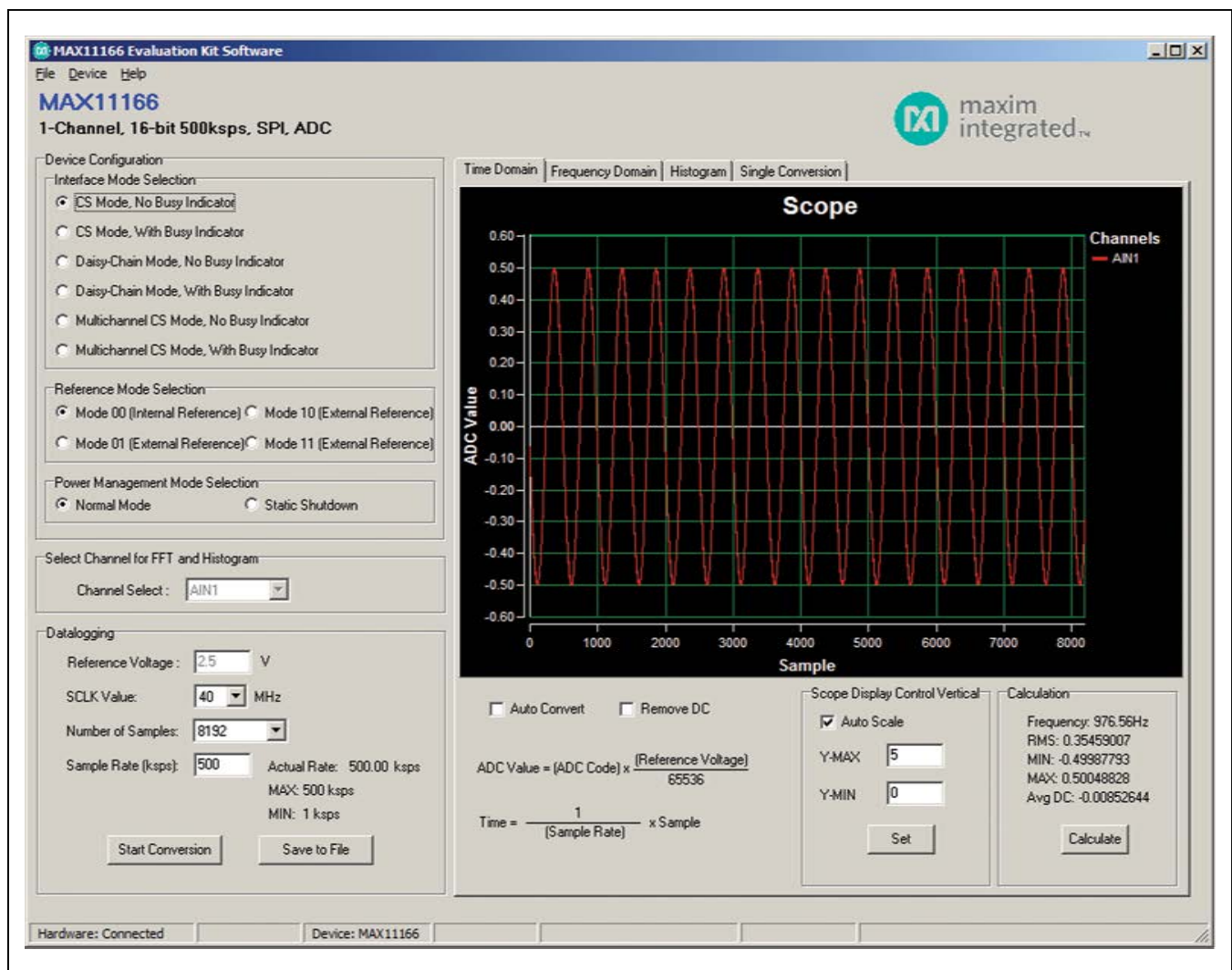

Figure 1. MAX11166 Evaluation System Software Main Window

### CS Mode (Single Channel)

The factory-default jumper settings have the ADCs on the daughter board configured for CS mode, using the MAX11166 (U1) only. In this configuration, the JU3 shunt is in position 1-3, JU12 is in position 1-2, and JU13 is in position 1-2. The mother board SPI MOSI drives U1 DIN through JU3, then U1 DOUT drives the mother board SPI MISO through JU5. U3 is not used. In the software, the **Device Configuration** group **Interface Mode Selection** must be set to **CS Mode**.

### Daisy-Chain Mode

To use the ADCs on the daughter board in daisy-chain mode, move the shunts of JU3, JU12, and JU13 to the 1-2 position. The mother board SPI MOSI drives U3 DIN, and U3 DOUT drives U1 DIN through JU3. Then, U1 DOUT drives the mother board SPI MISO through JU5. In the software, the **Device Configuration** group **Interface Mode Selection** must be set to **Daisy-Chain Mode**.

### Multichannel Mode

To use the ADCs on the daughter board in multichannel mode, move the shunts of JU3 to the 1-3 position, and move the shunts of JU12 and JU13 to the 2-3 position. The mother board SPI MOSI drives U1 DIN through JU3, then U1 DOUT drives the mother board SPI MISO through JU5. The mother board SPI MOSI drives U3 DIN directly, and U3 DOUT drives the mother board SPI MISO through JU12. U1 and U3 have different CONVST signals in this mode, with U1 CONVST driven through JU6 from CONVST1, and U3 CONVST driven through JU13 from CONVST2. In the software, the **Device Configuration** group **Interface Mode Selection** must be set to **Multichannel CS Mode**.

### Detailed Description of Hardware

The MAX11166 daughter board provides a proven layout for the device. An external reference, level translators, and SPI-interface pads are included on the daughter board.

#### Reference

Measure REFOUT at pin 2 of JU5 for all internal reference parts. Enter the value of the internal reference voltage into the **Set Vref** edit box in the software GUI.

For external reference parts, connect a reference voltage to pin 2 of JU5. Measure and enter the value of the external reference voltage into the **Set Vref** edit box of the software GUI.

#### User-Supplied SPI Interface

To use the daughter board with a user-supplied SPI interface, first move the shunts of JU1–JU4 to the 2-3 position. Next, apply your own 4.75V to 5.25V power supply at the VDD PCB pad. Lastly, connect your  $\overline{CS}$ , SCLK, and DIN signals to the corresponding  $\overline{CS}$ , SCLK, and DIN PCB pads on the daughter board.

#### User-Supplied Power Supply

The daughter board is powered completely from the USB port by default. Move the shunt of JU1 to the 2-3 position to apply your own 4.75V to 5.25V power supply at the VDD PCB pad.

**Table 1. MAXPRECADCMB Mother Board Jumper Settings**

JUMPER	SHUNT POSITION	DESCRIPTION
JU35	1-2	Connects the USB power to the input of the on-board LDO (U10).
	2-3*	Connects the external power supply to the input of the on-board LDO (U10).
JU36	1-2	Connects the USB power to the input of the on-board LDO (U11).
	2-3*	Connects the external power supply to the input of the on-board LDO (U11).
JU37	1-2	Connects the USB power to the input of the on-board LDO (U12).
	2-3*	Connects the external power supply to the input of the on-board LDO (U12).
JU38	1-2	Connects the USB power to the input of the on-board LDO (U13).
	2-3*	Connects the external power supply to the input of the on-board LDO (U13).
JU39	1-2	Connects the USB power to the input of the on-board LDO (U3).
	2-3*	Connects the external power supply to the input of the on-board LDO (U3).
JU40	Installed*	The on-board LDO (U10) provides a 3.3V output.
	Not installed	Disconnects the output of the on-board LDO (U10).
JU41	Installed*	The on-board LDO (U11) provides a 1.8V output.
	Not installed	Disconnects the output of the on-board LDO (U11).
JU42	Installed*	The on-board LDO (U12) provides a 2.5V output.
	Not installed	Disconnects the output of the on-board LDO (U12).
JU43	Installed*	The on-board LDO (U13) provides a 1.2V output.
	Not installed	Disconnects the output of the on-board LDO (U13).
JU44	1-2	Connects the IOVDD supply to the on-board 2.5V supply.
	1-3*	Connects the IOVDD supply to the on-board 3.3V supply from on-board U3.
	1-4	Connects the IOVDD supply to the on-board 2.5V supply.
	Not installed	IOVDD can be externally powered by the daughter board. IOVDD can be externally supplied by placing the IOVDD voltage on the IOVDD test point. The Altera FPGA cannot handle voltages greater than 3.3V.
JU45	1-2	Connects external (daughter board) SPI flash to the FGPA.
	2-3*	Connects on-board (mother board) SPI flash to the FGPA.

\*Default position.

Table 2. MAX11166 Daughter Board Jumper Descriptions (JU1–JU16)

JUMPER	SIGNAL	SHUNT POSITION	DESCRIPTION
JU1	U1.OVDD	1-2*	Connects the OVDD input of the IC to the output of the on-board 5V LDO.
		2-3	Connect the external OVDD power supply to the OVDD connector.
JU2	U1.VDD	1-2*	Connects the VDD input of the IC to the output of the on-board 5V LDO.
		2-3	Connect the external VDD power supply to the VDD connector.
JU3	U1.DIN	1-2	<b>(Interface Mode Selection = Daisy-Chain Mode)</b> Connects the DIN input of the first MAX11166 (U1) to the DOUT output of the second MAX11166 (U3) when JU12 is in the 1-2 position.
		1-3*	<b>(Interface Mode Selection = CS Mode)</b> <b>(Interface Mode Selection = Multichannel CS Mode)</b> Connects the DIN input of U1 to the FPGA.
		1-4	Connects the DIN input of the MAX11166 (U1) to the EXT_DIN connector.
JU4	U1.SCLK	1-2*	Connects the SCLK input of the IC to the FPGA.
		2-3	Connects the SCLK input of the IC to the EXT_SCLK connector.
JU5	U1.DOUT	1-2*	Connects the DOUT signal of the MAX11166 (U1) to the first DOUT pin (DOUT) of the FPGA.
		2-3	Connects the DOUT signal of the MAX11166 (U1) to the EXT_DOUT connector.
JU6	U1.CONVST	1-2*	Connects the CONVST signal of the MAX11166 (U1) to the FPGA.
		2-3	Connects the CONVST signal of the MAX11166 (U1) to the EXT_CONVST connector.
JU7	U1.REFIO	1-2*	Connects the REFIO of the MAX11166 to the on-board 4.096V reference.
		2-3	Connects the REFIO to the EXT_REF connector.
JU8	U1.AIN-	1-2*	Connects the AIN- input of the MAX11166 (U1) to ground.
		2-3	Connects the AIN1- connector to the AIN- input of the MAX11166 (U1).
JU9	U1.AIN+	1-2*	Connects the AIN1+ connector to the AIN+ input of the MAX11166 (U1).
		2-3	The output of the on-board buffer (U2) connects to the AIN+ input of the MAX11166 (U1).
JU10	U3.AIN+	1-2*	Connects the AIN2+ connector to the AIN+ input of the MAX11166 (U3).
		2-3	The output of the on-board buffer (U4) connects to the AIN+ input of the MAX11166 (U3).
JU11	U3.AIN-	1-2*	Connects the AIN- input of the MAX11166 (U3) to ground.
		2-3	Connects the AIN2- connector to the AIN- input of the MAX11166 (U3).
JU12	U3.DOUT	1-2*	<b>(Interface Mode Selection = CS Mode)</b> <b>(Interface Mode Selection = Daisy-Chain Mode)</b> Connects the DOUT signal of the second MAX11166 (U3) to the DIN pin of the first MAX11166 (U1) when JU3 is in the 1-2 position.
		2-3	<b>(Interface Mode Selection = Multichannel CS Mode)</b> Connects the DOUT signal of the MAX11166 (U3) to the DOUT pin of the FPGA.



**Table 2. MAX11166 Daughter Board Jumper Descriptions (JU1–JU16) (continued)**

JUMPER	SIGNAL	SHUNT POSITION	DESCRIPTION
JU13	U3.CONVST	1-2*	<b>(Interface Mode Selection = CS Mode)</b> <b>(Interface Mode Selection = Daisy-Chain Mode)</b> Connects the CONVST input of the MAX11166 (U3) to the first CONVST signal (CONVST1) of the FPGA.
		2-3	<b>(Interface Mode Selection = Multichannel CS Mode)</b> Connects the CONVST input of the MAX11166 (U3) to the second CONVST signal (CONVST2) of the FPGA.
JU14	U1.DOUT.R8	1-2*	(For interface modes with busy indicator.) Connects the pullup resistor to the DOUT output of the MAX11166 (U1).
		No shunt	Disconnects the pullup resistor from the MAX11166 (U1).
JU15	U8.5VL	1-2*	Connects the output of the LDO (U8) to the OVDD input of the IC when JU1 is in the 1-2 position.
		No shunt	Disconnects the output of the on-board LDO (U8).
JU16	U10.5V	1-2*	Connects the output of the LDO (U10) to the VDD input of the IC when JU2 is in the 1-2 position.
		No shunt	Disconnects the output of the on-board LDO (U10).

\*Default position.

### Component Lists

#### MAX11166 EV System

PART	QTY	DESCRIPTION
MAX11166DBEVKIT#	1	MAX11166 daughter board
MAXPRECADCMB#	1	Serial interface mother board

#### MAX11166 Daughter Board

DESIGNATION	QTY	DESCRIPTION
AIN1(+), AIN1(-), AIN2(+), AIN2(-)	4	Yellow multipurpose test points
C1, C2, C5, C11, C13–C19, C21, C23, C28, C111	15	0.1µF ±10%, 25V X7R ceramic capacitors (0603) Murata GRM188R71E104K
C3, C4, C8, C9, C25, C32, C33	7	1µF ±10%, 16V X7R ceramic capacitors (0603) Murata GRM188R71C105K
C6, C12	2	10µF ±10%, 25V X7R ceramic capacitors (1210) Murata GRM32DR71E106K

DESIGNATION	QTY	DESCRIPTION
C7, C10, C30, C31	4	4700pF ±5%, 50V C0G ceramic capacitors (0603) Murata GRM188R71H472K
C20, C29	2	2.2µF ±10%, 10V X7R ceramic capacitors (0603) Murata GRM188R71A225K
C22	1	10µF ±10%, 6.3V X5R ceramic capacitor (0603) Murata GRM188R60J106K
C24	1	4.7µF ±10%, 6.3V X5R ceramic capacitor (0603) Murata GRM188R60J475K

## Component Lists (continued)

## MAX11166 Daughter Board (continued)

DESIGNATION	QTY	DESCRIPTION
C26	1	1000pF ±10%, 50V X7R ceramic capacitor (0603) Murata GRM188R71H102K
C27	1	4.7µF ±10%, 16V X5R ceramic capacitor (0805) Murata GRM21BR61C475K
D1	1	Red LED (0603)
EXT_VCC, EXT_VEE, OVDD, VDD	4	Red multipurpose test points
EXT_CONVST, EXT_DIN, EXT_DOUT, EXT_RDC, EXT_REF, EXT_SCLK	6	White multipurpose test points
GND-POS	6	Black multipurpose test points
J1	1	Shrouded 2mm right-angle header (2 x 20) Samtec LS2-120-01-S-D-RA2
JU1, JU2, JU4-JU13	12	3-pin headers
JU3	1	4-pin header
JU14-JU16	3	2-pin headers
R1, R2, R12, R13	4	10Ω ±5% resistors (0603)
R3	1	470Ω ±5% resistor (0603)
R4-R7, R14, R15	6	49.9Ω ±1% resistors (0603)

DESIGNATION	QTY	DESCRIPTION
R8	1	15kΩ ±5% resistor (0603)
R10	1	357kΩ ±1% resistor (0603)
R11	1	51.1kΩ ±1% resistor (0603)
U1, U3	2	16-bit, 500ksps/250ksps, ±5V SAR ADCs with internal reference (12 TDFN-EP*) Maxim MAX11166ETC+
U2, U4	2	Precision low-noise amplifiers (8 SO) Maxim MAX9632ASA+
U5	1	4.096V voltage reference (8 SO) Maxim MAX6126AASA41+
U6	1	Digital isolator, 4 up/0 down Analog Devices ADUM3400CRWZ
U7	1	Digital isolator, 2 up/2 down Analog Devices ADUM3402CRWZ
U8, U10	2	5V LDO regulators (8 SO) Maxim MAX883CSA+
U9	1	10V LDO regulator (8 SO-EP*) Maxim MAX16910CASA9/V+
U11	1	SPI serial flash Micron M25P16-VMW6TG
—	16	Shunts
—	1	PCB: MAX11166DB EVALUATION KIT

\*EP = Exposed pad.



## Component Lists (continued)

## MAXPRECADCMB Mother Board

DESIGNATION	QTY	DESCRIPTION
10MHZCLK	1	50Ω SMA female jack Emerson 142-0701-201
BUTTON, CPU_RESET, RECONFIGURE	3	Momentary pushbutton switches (6mm)
C1, C3	2	1000pF ±5%, 50V C0G ceramic capacitors (0603) Murata GRM1885C1H102J
C2, C4, C31, C43, C47, C55–C72, C78–C80, C82, C84, C86	29	0.1μF ±10%, 25V X7R ceramic capacitors (0603) Murata GRM188R71E104K
C5–C29	25	0.1μF ±10%, 16V X7R ceramic capacitors (0402) Murata GRM155R71C104K
C30, C38–C41, CB1–CB3	8	1μF ±10%, 16V X7R ceramic capacitors (0603) Murata GRM188R71C105K
C32	1	0.01μF ±10%, 16V X7R ceramic capacitor (0603) Murata GRM188R71C103K
C44, C45, C130, CP2, CP3	5	10μF ±20%, 6.3V X5R ceramic capacitors (0603) Murata GRM188R60J106M
C73, C129	2	4.7μF ±10%, 6.3V X5R ceramic capacitors (0603) Murata GRM188R60J475K
C74	0	Not installed, capacitor (0603)
C75, C76	2	18pF ±5%, 50V C0G ceramic capacitors (0603) Murata GRM1885C1H180J
C77, C81	2	10μF ±20%, 10V tantalum capacitors (3528-21) KEMET T491B106M010AT
C83, C85	2	4.7μF ±20%, 25V tantalum capacitors (1210) AVX TAJB475M025R

DESIGNATION	QTY	DESCRIPTION
CC1–CC4	4	10pF ±5%, 50V C0G ceramic capacitors (0603) Murata GRM1885C1H100J
CP1	1	100μF ±20%, 6.3V X5R ceramic capacitor (1210) Murata GRM32ER60J107M
GND	3	Black multipurpose test points Keystone 5011
H2	0	Not installed, 16-pin (2 x 8) dual-row header
IOVDD, VIN	2	Red multipurpose test points Keystone 5010
J1	1	Shrouded 2mm right-angle 40-pin (2 x 20) header SAMTEC LS2-120-01-S-D-RA1
J2	1	USB type-B right-angle female receptacle
JTAG1, JTAG2	2	10-pin (2 x 5) dual-row headers
JUC1–JUC7	0	Not installed, 3-pin headers
JU35–JU39, JU45	6	3-pin headers
JU40–JU43	4	2-pin headers
JU44	1	4-pin header
L1	1	300Ω ±25%, 500mA ferrite bead (0603) TDK MMZ1608R301A
LED1–LED4	4	Red LEDs (0603)
R1, R2, R5–R7, R95	6	100kΩ ±5% resistors (0603)
R36	1	0Ω ±1% resistor (0603)
R10, R33	2	22Ω ±5% resistors (0603)
R11–R21	11	5.1kΩ ±5% resistors (0603)
R22–R25, R28, R34, R35, R41, R97	9	10.0kΩ ±1% resistors (0603)
R26, R96	2	16.5kΩ ±1% resistors (0603)
R27	1	4.42kΩ ±1% resistor (0603)
R29	1	20.0kΩ ±1% resistor (0603)

## Component Lists (continued)

### MAXPRECADCMB Mother Board (continued)

DESIGNATION	QTY	DESCRIPTION
R30, RC1–RC7	8	10k $\Omega$ $\pm$ 5% resistors (0603)
R31	0	Not installed, resistor (0603)
R32	1	12.1k $\Omega$ $\pm$ 1% resistor (0603)
RC8–RC10	3	1.0k $\Omega$ $\pm$ 5% resistors (0603)
RL1–RL4	4	120 $\Omega$ $\pm$ 5% resistors (0603)
RN14–RN21	8	22 $\Omega$ $\pm$ 5%, 1/16W resistor networks (8 pins) Panasonic EXB-2HV220JV
RN22	1	5.1k $\Omega$ resistor network Yageo TC164-JR-075K1L
RN25	1	10k $\Omega$ resistor network Panasonic EXB-38V103JV
S1	1	4-position SMT, half-pitch DIP switch CTS 218-4LPST
TP2, TP3, TPUSB5V	0	Not installed, multipurpose test points
U2	1	Altera Cyclone III FPGA Altera EP3C25F324C8N
U3, U10–U12	4	LDOs (16 TSSOP-EP*) Maxim MAX1793EUE50+ Maxim MAX1793EUE33+ Maxim MAX1793EUE25+ Maxim MAX1793EUE18+

\*EP = Exposed pad.

DESIGNATION	QTY	DESCRIPTION
U5	1	SSRAM 256K x 36 (100 TQFP) ISSI IS61LPS25636A-200TQLI
U6	0	Not installed, flash 32M x 16 (64 EBGA) Numonyx/Intel PC28F256P30BFA
U7	1	SPI flash memory EPCS16 (8 SO) Altera EPCS16SI8N
U13	1	LDO (6 SOT23) Maxim MAX1983EUT+
U14	1	SRAM (48 TSOP) Cypress CY62167DV30LL-55ZXI
U15	1	USB PHY (SOT617-1) ST Ericsson ISP1504ABS
Y1	1	3.3V, 50MHz oscillator (7mm x 5mm) ECS-3953M-500-BN
Y2	1	19.2MHz, 18pF SMD crystal Citizen CS325 19.200MABJ-UT
—	1	USB high-speed A-to-B cable, 6ft
—	11	Shunts
—	1	PCB: MAXPRECADCMB EVKIT

## Component Suppliers

SUPPLIER	PHONE	WEBSITE
Hong Kong X'tals Ltd.	852-35112388	www.hongkongcrystal.com
Murata Americas	770-436-1300	www.murataamericas.com
TDK Corp.	847-803-6100	www.component.tdk.com

**Note:** Indicate that you are using the MAX11166 when contacting these manufacturers.

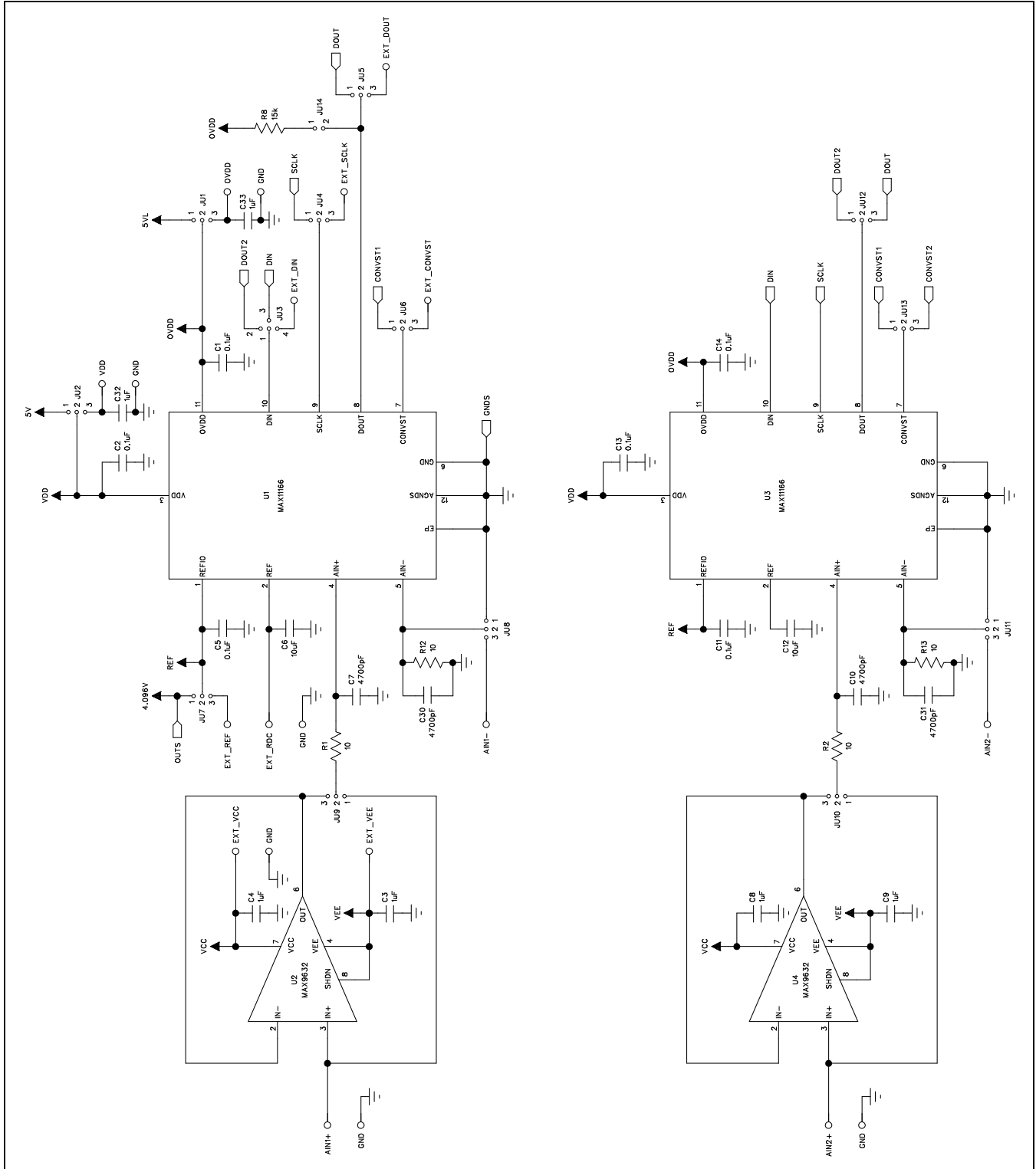

Figure 2a. MAX11166 Daughter Board Schematic (Sheet 1 of 2)

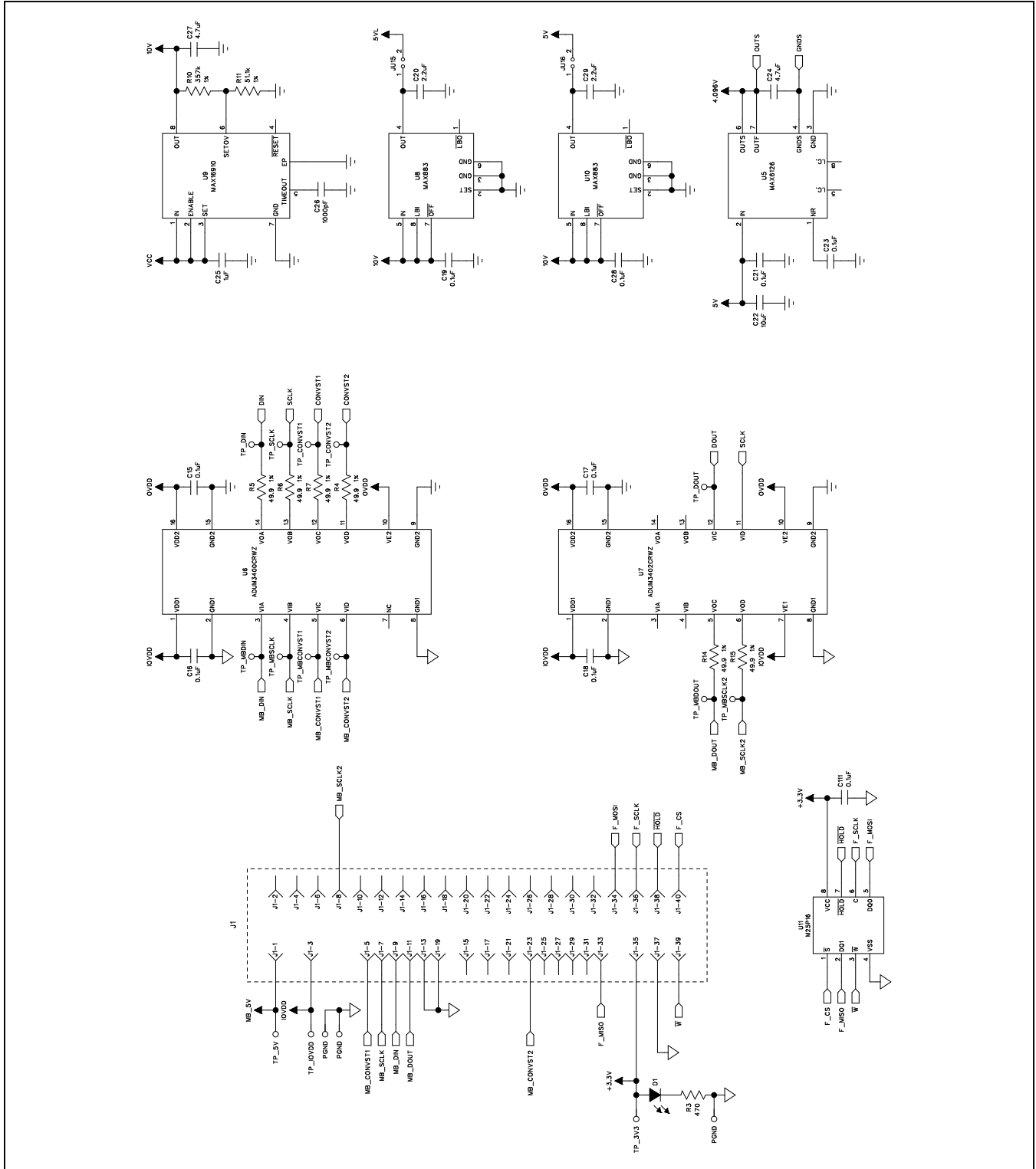

Figure 2b. MAX11166 Daughter Board Schematic (Sheet 2 of 2)

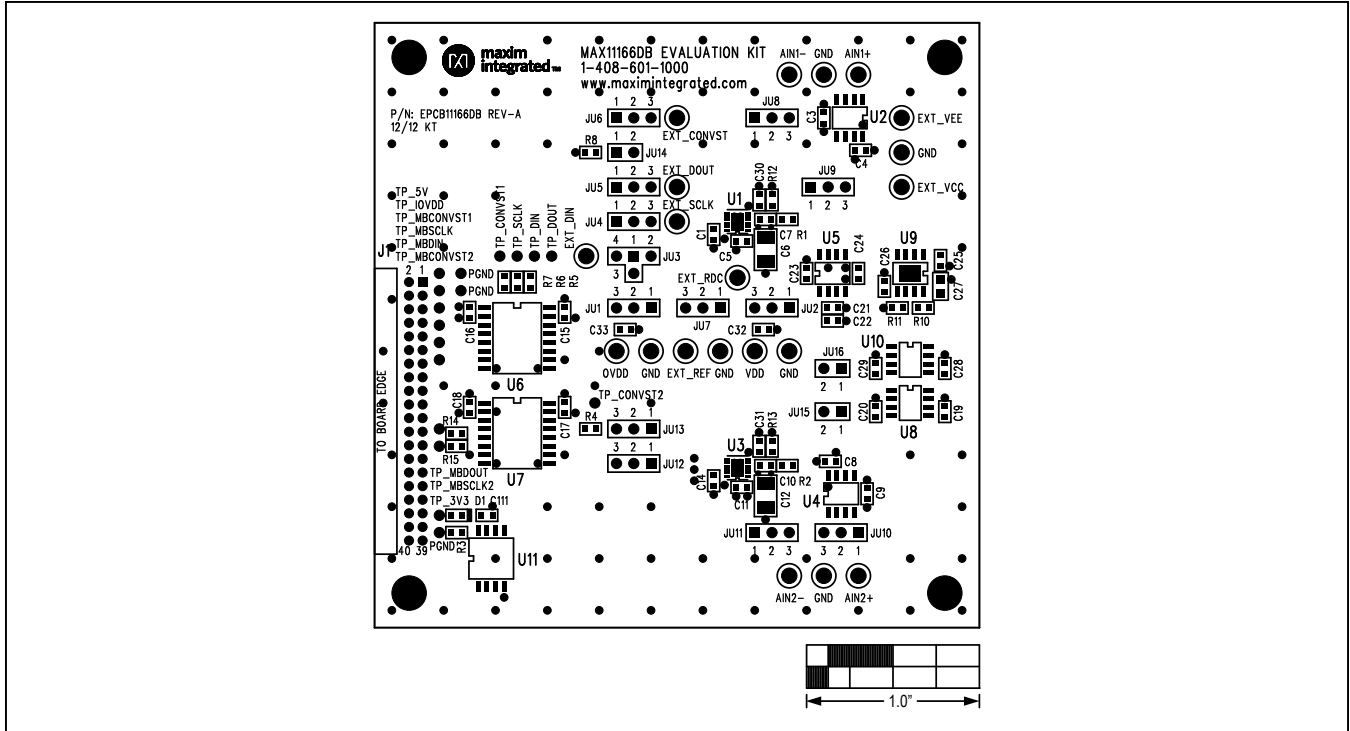

Figure 3. MAX11166 Daughter Board Component Placement Guide—Component Side

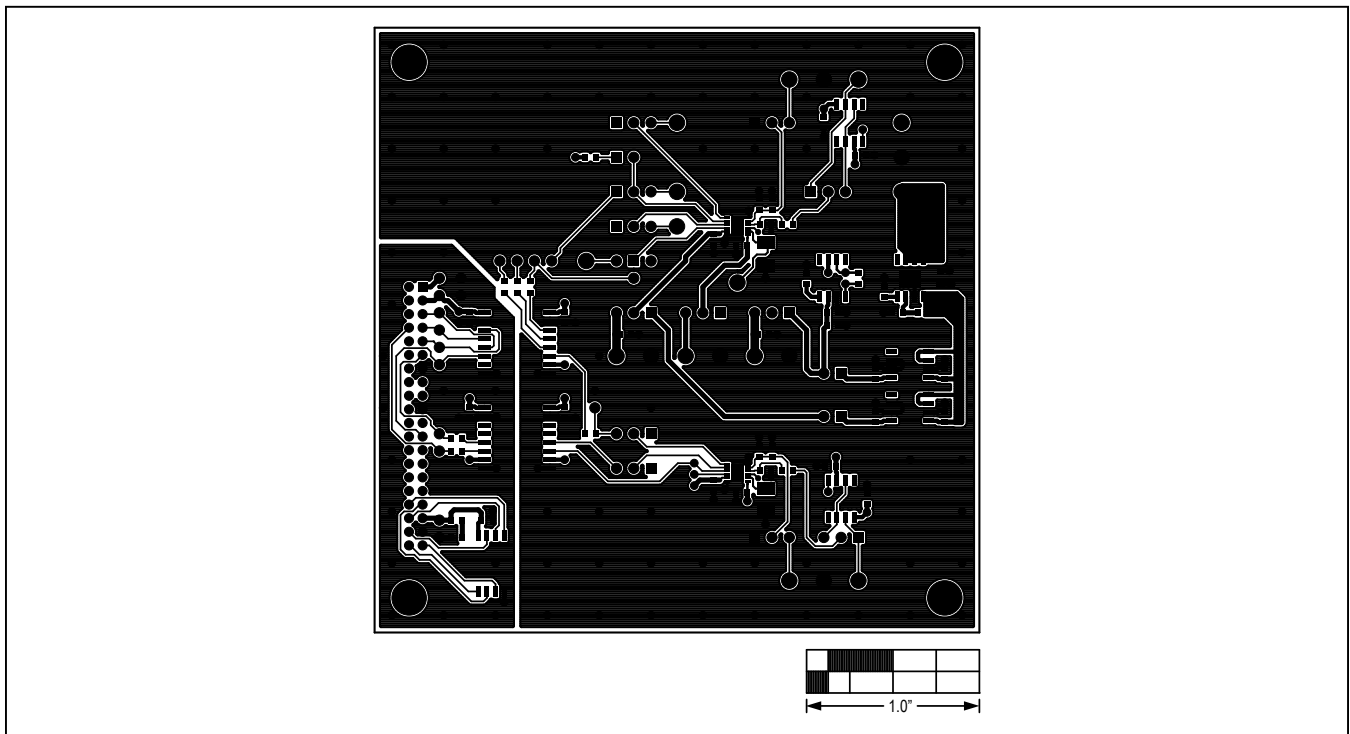

Figure 4. MAX11166 Daughter Board PCB Layout—Component Side

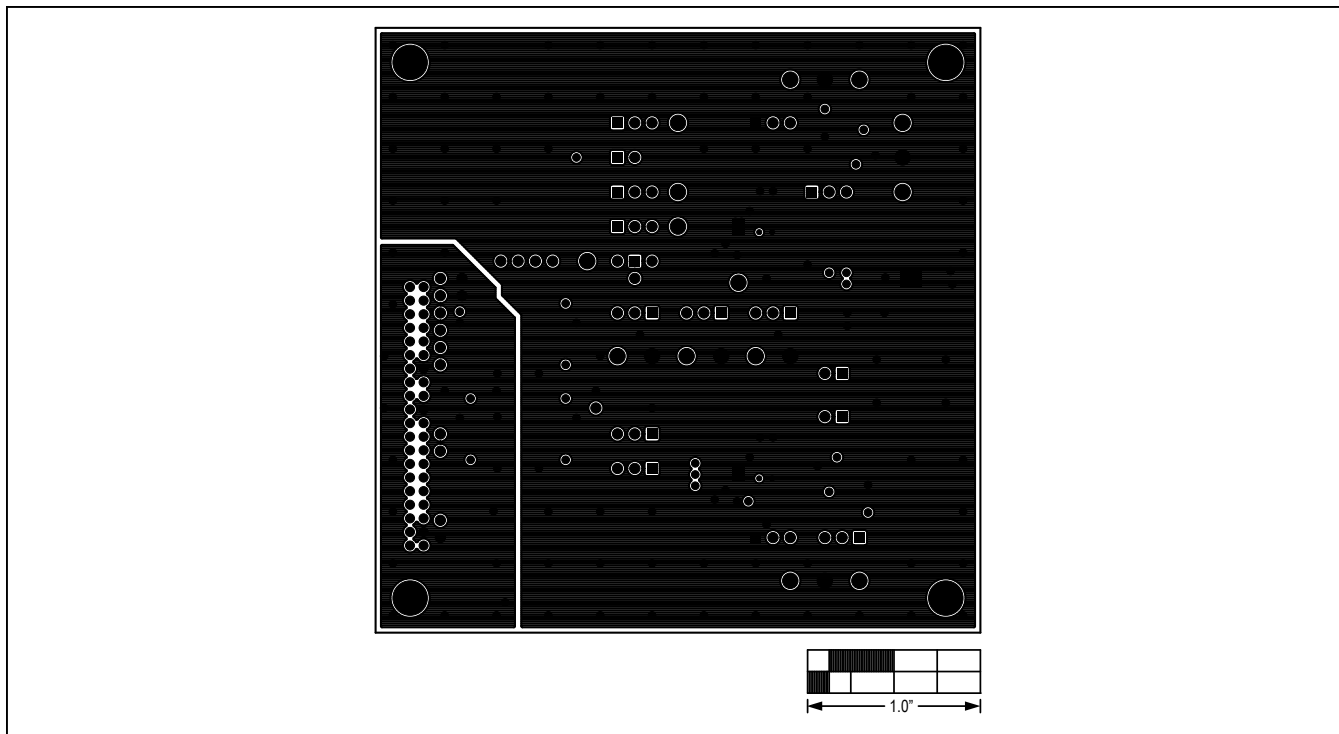

Figure 5. MAX11166 Daughter Board PCB Layout—Ground Layer 2

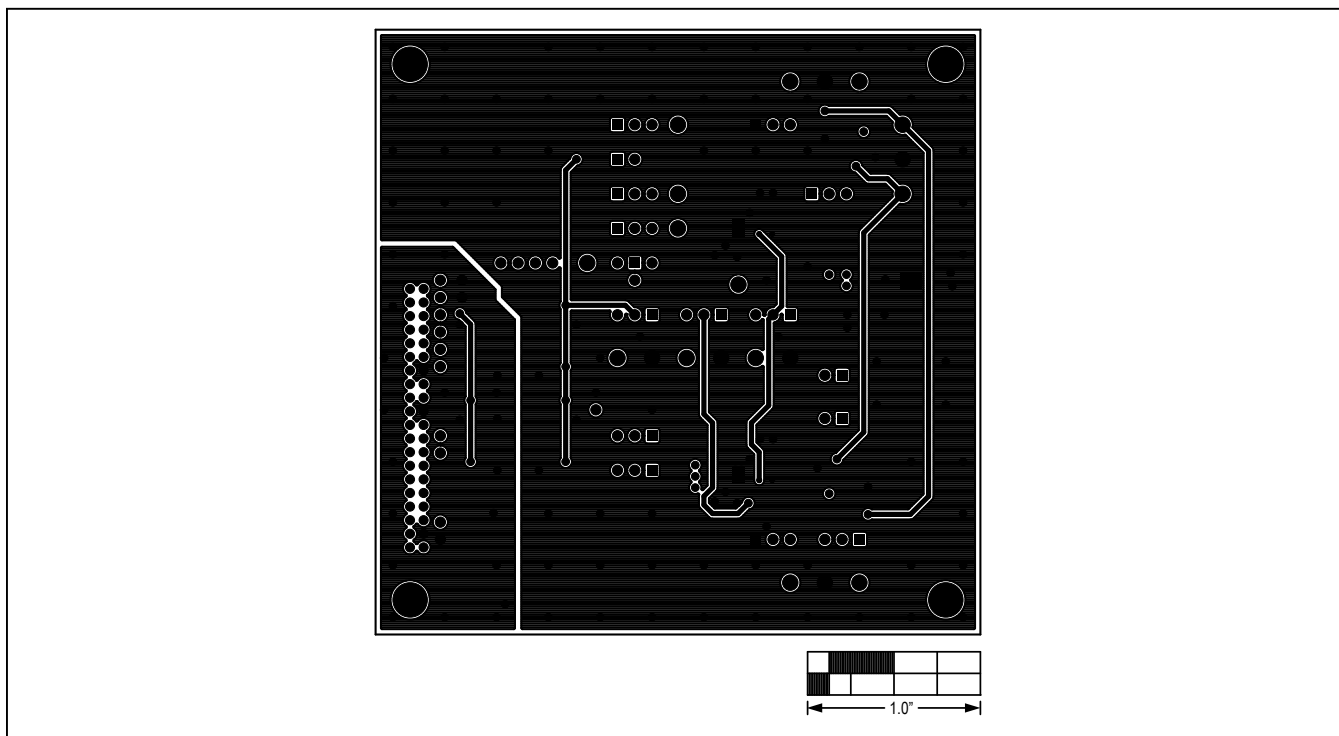

Figure 6. MAX11166 Daughter Board PCB Layout—Power Layer 3

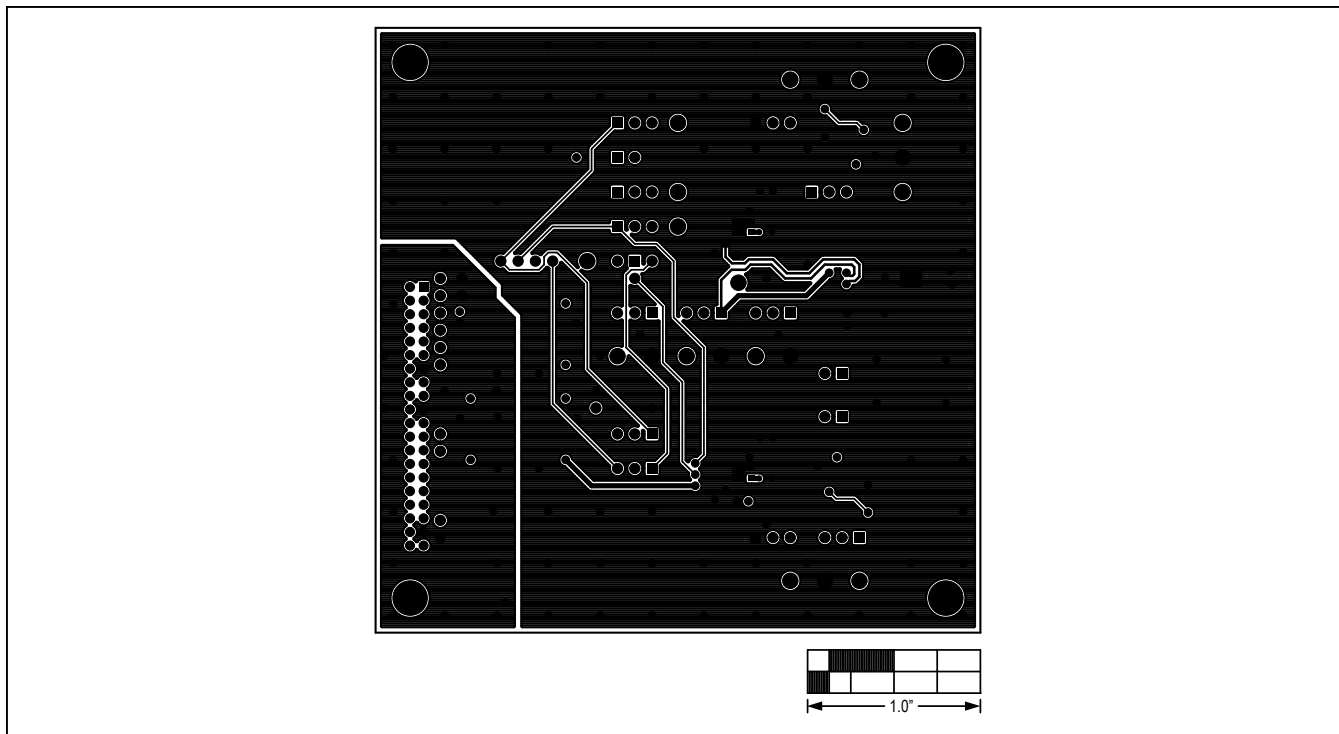

Figure 7. MAX11166 Daughter Board PCB Layout—Solder Side

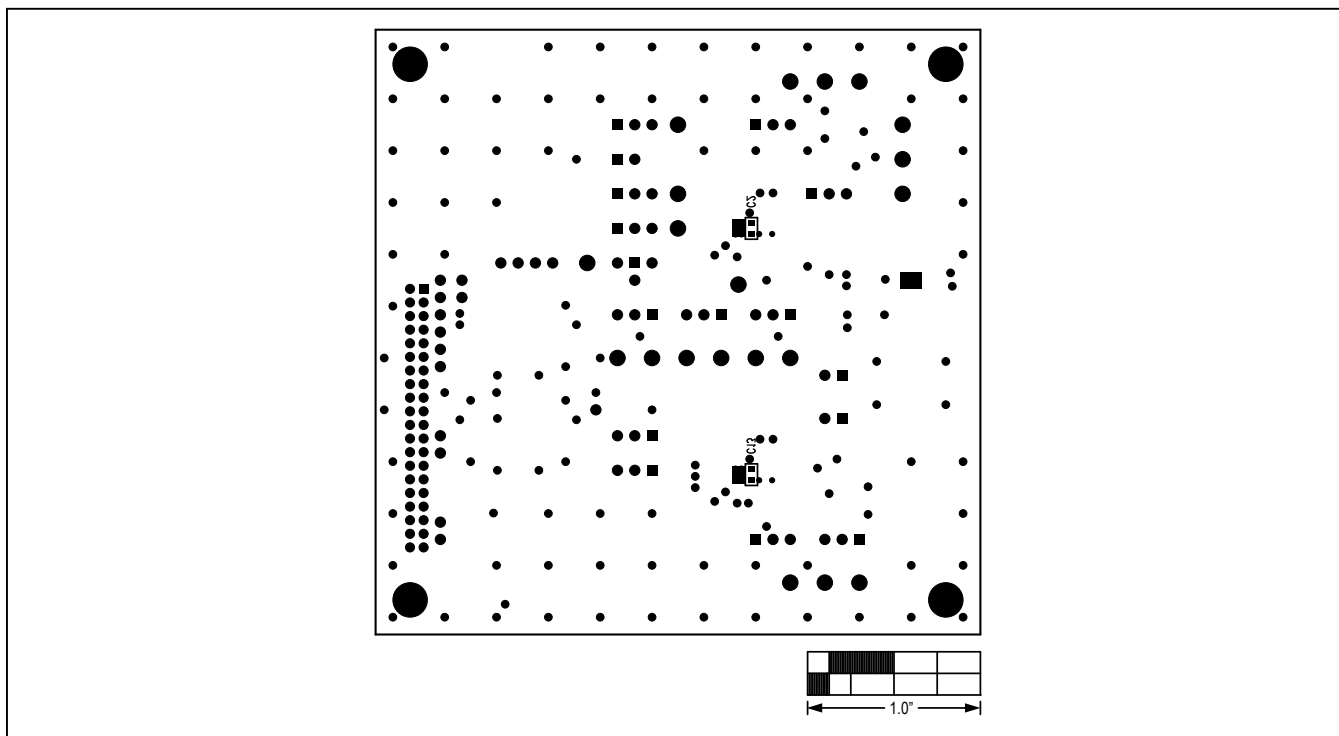

Figure 8. MAX11166 Daughter Board Component Placement Guide—Solder Side



### Ordering Information

PART	TYPE
MAX11166EVSYS#	EV System

*#Denotes RoHS compliant.*

## Revision History

REVISION NUMBER	REVISION DATE	DESCRIPTION	PAGES CHANGED
0	6/13	Initial release	—

For pricing, delivery, and ordering information, please contact Maxim Direct at 1-888-629-4642, or visit Maxim Integrated's website at [www.maximintegrated.com](http://www.maximintegrated.com).

*Maxim Integrated cannot assume responsibility for use of any circuitry other than circuitry entirely embodied in a Maxim Integrated product. No circuit patent licenses are implied. Maxim Integrated reserves the right to change the circuitry and specifications without notice at any time.*



## Стандарт Электрон Связь

Мы молодая и активно развивающаяся компания в области поставок электронных компонентов. Мы поставляем электронные компоненты отечественного и импортного производства напрямую от производителей и с крупнейших складов мира.

Благодаря сотрудничеству с мировыми поставщиками мы осуществляем комплексные и плановые поставки широчайшего спектра электронных компонентов.

Собственная эффективная логистика и склад в обеспечивает надежную поставку продукции в точно указанные сроки по всей России.

Мы осуществляем техническую поддержку нашим клиентам и предпродажную проверку качества продукции. На все поставляемые продукты мы предоставляем гарантию .

Осуществляем поставки продукции под контролем ВП МО РФ на предприятия военно-промышленного комплекса России , а также работаем в рамках 275 ФЗ с открытием отдельных счетов в уполномоченном банке. Система менеджмента качества компании соответствует требованиям ГОСТ ISO 9001.

Минимальные сроки поставки, гибкие цены, неограниченный ассортимент и индивидуальный подход к клиентам являются основой для выстраивания долгосрочного и эффективного сотрудничества с предприятиями радиоэлектронной промышленности, предприятиями ВПК и научно-исследовательскими институтами России.

С нами вы становитесь еще успешнее!

### Наши контакты:

**Телефон:** +7 812 627 14 35

**Электронная почта:** [sales@st-electron.ru](mailto:sales@st-electron.ru)

**Адрес:** 198099, Санкт-Петербург,  
Промышленная ул, дом № 19, литера Н,  
помещение 100-Н Офис 331