

DATA SHEET

SKY12210-478LF: 0.9 to 4.0 GHz, 100 W High Power Silicon PIN Diode SPDT Switch

Applications

- Transmit/receive switching and failsafe switching in TD-SCDMA, WiMAX, and LTE base stations
- Transmit/receive switching in land mobile radios and military communication systems

Features

- High power handling: 100 W CW, 480 W peak
- Low insertion loss: 0.4 dB typical
- High antenna to receive isolation: 44 dB @ 2.6 GHz typical
- Controlled with positive power supply
- Bias driver circuit available on request
- Small, QFN (16-pin, 4 x 4 mm) Pb-free package (MSL1, 260 °C per JEDEC J-STD-020)



Skyworks Green™ products are compliant with all applicable legislation and are halogen-free. For additional information, refer to *Skyworks Definition of Green™*, document number SQ04-0074.

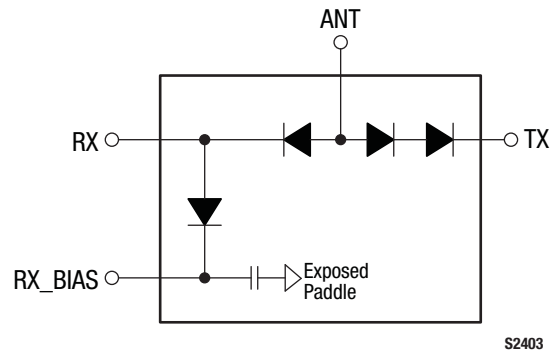

Figure 1. SKY12210-478LF Block Diagram

Description

The SKY12210-478LF is a high power handling, single-pole, double-throw (SPDT) silicon PIN diode switch. The device operates over the 900 MHz to 4 GHz band. It features low insertion loss, excellent power handling, and superb linearity with low DC power consumption.

The SKY12210-478LF is well-suited for use as a high power transmit/receive switch in a variety of telecommunication systems such as WiMAX, TD-SCDMA, or LTE base stations.

The device is provided in a 4 x 4 mm, 16-pin Quad Flat No-Lead (QFN) package. A functional block diagram is shown in Figure 1. The pin configuration and package are shown in Figure 2. Signal pin assignments and functional pin descriptions are provided in Table 1.

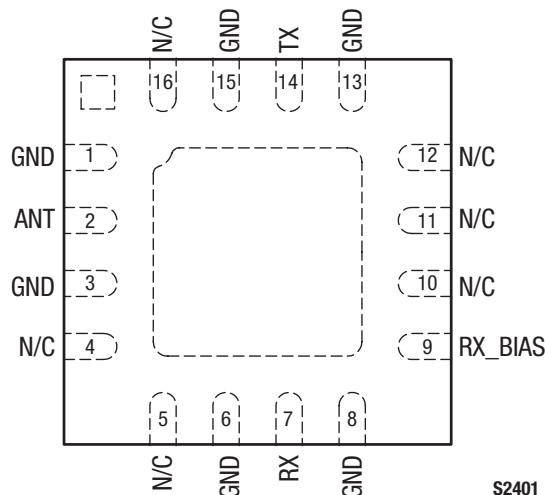

Figure 2. SKY12210-478LF Pinout – 16-Pin QFN (Top View)

Table 1. SKY12210-478LF Signal Descriptions

Pin	Name	Description	Pin	Name	Description
1	GND	Ground. Must be connected to ground using lowest possible impedance.	9	RX_BIAS	RF ground port and DC bias input port
2	ANT	Antenna RF port and DC bias input port	10	N/C	No connection
3	GND	Ground. Must be connected to ground using lowest possible impedance.	11	N/C	No connection
4	N/C	No connection	12	N/C	No connection
5	N/C	No connection	13	GND	Ground. Must be connected to ground using lowest possible impedance.
6	GND	Ground. Must be connected to ground using lowest possible impedance.	14	TX	Transmit RF input port and DC bias input port
7	RX	Receive output port and DC bias input port	15	GND	Ground. Must be connected to ground using lowest possible impedance.
8	GND	Ground. Must be connected to ground using lowest possible impedance.	16	N/C	No connection

Electrical and Mechanical Specifications

The absolute maximum ratings of the SKY12210-478LF are provided in Table 2. Recommended operating conditions are specified in Table 3 and electrical specifications are provided in Table 4.

Typical performance characteristics of the SKY12210-478LF are illustrated in Figures 3 through 9.

The state of the SKY12210-478LF is determined by the logic provided in Table 6. Table 7 provides the logic for use with the SKY12210-478LF Evaluation Board.

Power derating data is plotted against temperature in Figures 10 and 11. Equivalent circuit diagrams for transmit and receive are shown in Figure 12.

Table 2. SKY12210-478LF Absolute Maximum Ratings (Note 1)

Parameter	Symbol	Minimum	Maximum	Units
RF CW input power, TX and ANT ports ($T_{\text{SUBSTRATE}} = 25\text{ }^{\circ}\text{C}$)	P_{IN}		120	W
RF peak input power, TX and ANT ports ($T_{\text{SUBSTRATE}} = 25\text{ }^{\circ}\text{C}$, RF burst width = 10 μs , RF burst repetition rate = 25 kHz)	P_{IN}		480	W
RF CW input power, RX port ($T_{\text{SUBSTRATE}} = 25\text{ }^{\circ}\text{C}$)	P_{IN}		60	W
RF peak input power, RX port ($T_{\text{SUBSTRATE}} = 25\text{ }^{\circ}\text{C}$, RF burst width = 10 μs , RF burst repetition rate = 25 kHz)	P_{IN}		240	W
Control port reverse voltage	V_{CTL}		200	V
Control port forward current	I_{CTL}		200	mA
Operating temperature	T_{OP}	-55	+175	$^{\circ}\text{C}$
Storage temperature	T_{STG}	-55	+200	$^{\circ}\text{C}$
Electrostatic discharge:	ESD			
Charged Device Model (CDM), Class 4			1000	V
Human Body Model (HBM), Class 1C			1500	V
Machine Model (MM), Class B			200	V

Note 1: Exposure to maximum rating conditions for extended periods may reduce device reliability. There is no damage to device with only one parameter set at the limit and all other parameters set at or below their nominal value. Exceeding any of the limits listed here may result in permanent damage to the device.

CAUTION: Although this device is designed to be as robust as possible, electrostatic discharge (ESD) can damage this device. This device must be protected at all times from ESD. Static charges may easily produce potentials of several kilovolts on the human body or equipment, which can discharge without detection. Industry-standard ESD precautions should be used at all times.

Table 3. Recommended Operating Conditions (Per ANT, TX, RX, and RX_BIAS Inputs)

Parameter	Symbol	Min	Typical	Max	Units
Control port reverse voltage	V_{CTL}	5	28	100	V
Control port forward current	I_{CTL}	50	100	100	mA

Table 4. SKY12210-478LF Electrical Specifications (1 of 2) (Note 1)
(T_{OP} = +25 °C, Characteristic Impedance [Z₀] = 50 Ω, EVB Optimized for 2.6 GHz Operation, Unless Otherwise Noted)

Parameter	Symbol	Test Condition	Min	Typical	Max	Units
Insertion loss, TX to ANT ports	IL _{TX-ANT}	V _{PIN_2} = 2 V, I _{PIN_14} = -100 mA, I _{PIN_9} = -100 mA, V _{PIN_7} = 28 V, TX port P _{IN} @ pin 14 = 0 dBm: 900 MHz 1.80 GHz 2.01 GHz 2.60 GHz 3.50 GHz		0.52		dB
				0.33		dB
				0.38		dB
				0.48	0.70	dB
				0.47	0.70	dB
Insertion loss, ANT to RX ports	IL _{ANT-RX}	V _{PIN_2} = 1 V, V _{PIN_14} = 28 V, I _{PIN_7} = -133 mA, V _{PIN_9} = 28 V, ANT port P _{IN} @ pin 2 = 0 dBm: 900 MHz 1.80 GHz 2.01 GHz 2.60 GHz 3.50 GHz		0.56		dB
				0.26		dB
				0.29		dB
				0.34	0.50	dB
				0.36	0.50	dB
Isolation, TX to RX ports	Iso _{TX-RX}	V _{PIN_2} = 1 V, I _{PIN_14} = -100 mA, I _{PIN_9} = -100 mA, V _{PIN_7} = 28 V, TX port P _{IN} @ pin 14 = 0 dBm: 900 MHz 1.80 GHz 2.01 GHz 2.60 GHz 3.50 GHz		34		dB
				37		dB
				39		dB
			40	50		dB
			31	34		dB
Isolation, ANT to TX ports	Iso _{ANT-TX}	V _{PIN_2} = 1 V, V _{PIN_14} = 28 V, I _{PIN_7} = -133 mA, V _{PIN_9} = 28 V, ANT port P _{IN} @ pin 2 = 0 dBm: 900 MHz 1.80 GHz 2.01 GHz 2.60 GHz 3.50 GHz		35		dB
				30		dB
				29		dB
			25	28		dB
			22	25		dB
Isolation, ANT to RX ports	Iso _{ANT-RX}	V _{PIN_2} = 2 V, I _{PIN_14} = -100 mA, I _{PIN_9} = -100 mA, V _{PIN_7} = 28 V, ANT port P _{IN} @ pin 2 = 0 dBm: 900 MHz 1.8 to 2.1 GHz 2.3 to 2.7 GHz 2.6 GHz 3.5 GHz		33		dB
				36	37	dB
				37	43	dB
				40	44	dB
				30	33	dB
Input return loss		1.8 to 3.5 GHz: RX insertion loss state, ANT port (@ pin 2)		25		dB
		TX insertion loss state, TX port (@ pin 14)		20		dB

Table 4. SKY12210-478LF Electrical Specifications (2 of 2) (Note 1)
(TOP = +25 °C, Characteristic Impedance [Z₀] = 50 Ω, EVB Optimized for 2.6 GHz Operation, Unless Otherwise Noted)

Parameter	Symbol	Test Condition	Min	Typical	Max	Units
Transmit 2 nd harmonic	2fo	TX insertion loss state, TX port P _{IN} @ pin 14 = +30 dBm: 900 MHz 1.80 GHz 2.01 GHz 2.60 GHz 3.50 GHz		-88 -85 -95 -95 -89		dBc dBc dBc dBc dBc
Transmit 3 rd harmonic	3fo	TX insertion loss state, TX port P _{IN} @ pin 14 = +30 dBm: 900 MHz 1.80 GHz 2.01 GHz 2.60 GHz 3.50 GHz		-99 -97 -105 -97 -90		dBc dBc dBc dBc dBc
Transmit 3 rd Order Input Intercept Point	IIP3	V _{PIN_2} = 2 V, I _{PIN_14} = -100 mA, I _{PIN_9} = -100 mA, V _{PIN_7} = 28 V, TX port P _{IN} @ pin 14 = +30 dBm/tone, tone spacing = 1 MHz: @ 2.6 GHz		+78		dBm
Transmit 0.1 dB Input Compression Point	IPO.1dB	V _{PIN_2} = 2 V, I _{PIN_14} = -100 mA, I _{PIN_9} = -100 mA, V _{PIN_7} = 28 V: @ 1.8 to 2.6 GHz		+49		dBm
Receive 0.1 dB Input Compression Point	IPO.1dB	V _{PIN_2} = 1 V, V _{PIN_14} = 28 V, I _{PIN_7} = -133 mA, V _{PIN_9} = 28 V: @ 1.8 to 2.6 GHz		+46		dBm
Maximum transmit CW input power	P _{IN_CW}	V _{PIN_2} = 2 V, I _{PIN_14} = -100 mA, I _{PIN_9} = -100 mA, V _{PIN_7} = 28 V: @ 0.9 to 3.5 GHz		100		W
Maximum receive CW input power	P _{IN_CW}	V _{PIN_2} = 1 V, V _{PIN_14} = 28 V, I _{PIN_7} = -133 mA, V _{PIN_9} = 28 V: @ 0.9 to 3.5 GHz		40		W
Transmit RF switching time	t _{sw}	10% to 90% RF on, repetition rate = 0.1 MHz, @ 2.60 GHz		157		ns
Thermal resistance (junction to case)	Θ _{JC}			14		°C/W

Note 1: Performance is guaranteed only under the conditions listed in this table.

Typical Performance Characteristics

($T_{op} = +25\text{ }^{\circ}\text{C}$, Characteristic Impedance $[Z_0] = 50\ \Omega$, EVB Optimized for 2.6 GHz Operation, Bias = 28 V/100 mA, Unless Otherwise Noted)

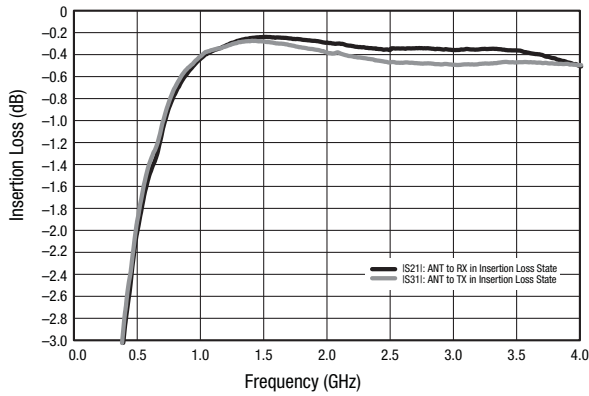

Figure 3. Insertion Loss vs Frequency

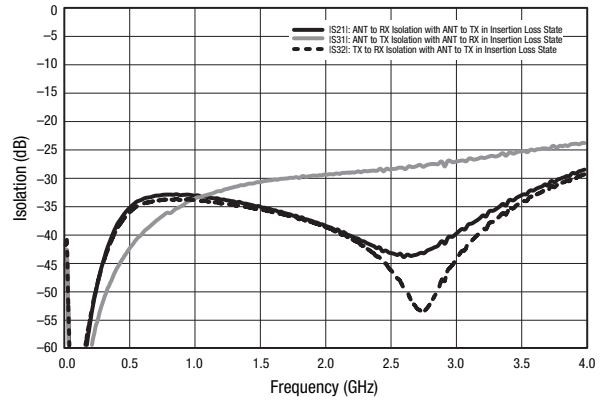

Figure 4. Isolation vs Frequency

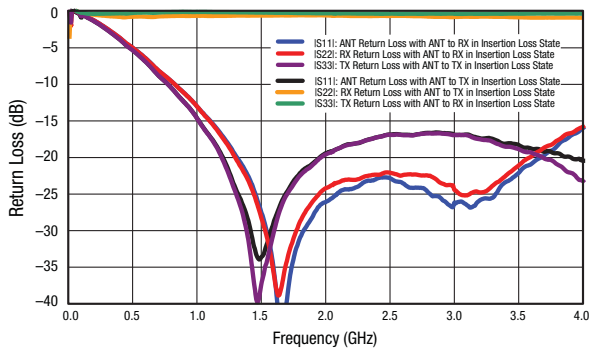

Figure 5. Return Loss vs Frequency

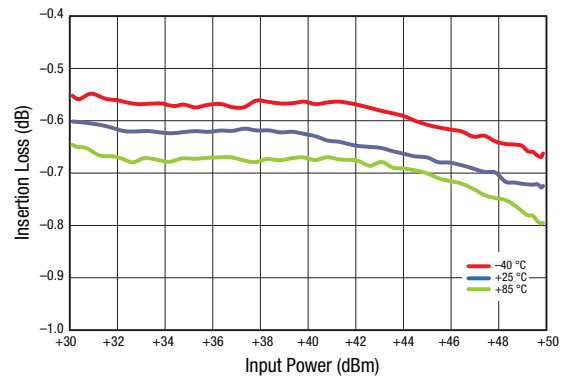

Figure 6. Insertion Loss vs CW Input Power (TX to ANT Port, $f = 2600\text{ MHz}$, 28 V, 100 mA, EVB Loss Included)

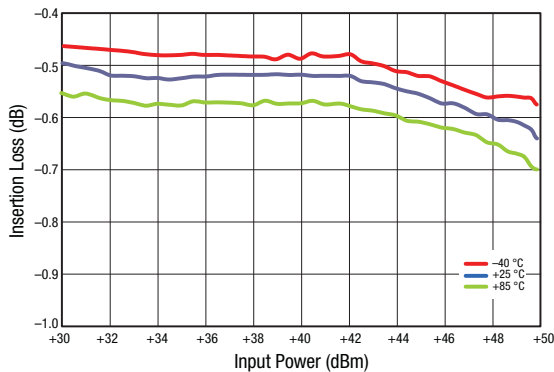

Figure 7. Insertion Loss vs CW Input Power (TX to ANT Port, $f = 2300\text{ MHz}$, 28 V, 100 mA, EVB Loss Included)

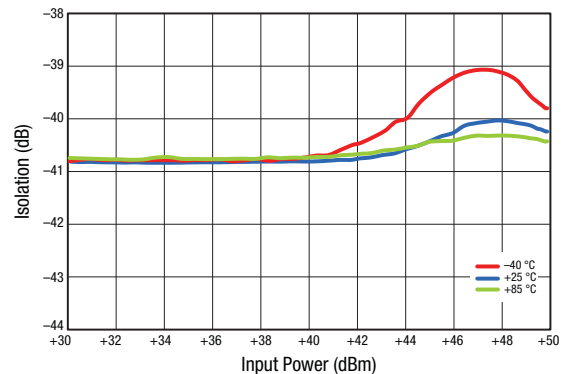

Figure 8. Isolation vs CW Input Power (ANT to RX Port, $f = 2300\text{ MHz}$, 28 V, 100 mA, EVB Loss Included)

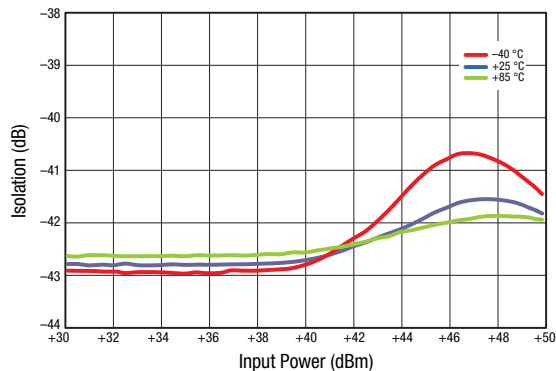

Figure 9. Isolation vs CW Input Power (ANT to RX Port, f = 2600 MHz, 28 V, 100 mA, EVB Loss Included)

Table 5. SKY12210-478LF Truth Table

Switch State	Path		Control Conditions			
	Antenna-to-Receiver Port (Pin 2 to Pin 7)	Transmitter-to-Antenna Port (Pin 14 to Pin 2)	Antenna Port Bias Input (Pin 2)	Nominal Receiver Output Port (Pin 7)	Nominal Transmitter Port Bias Input (Pin 14)	RX_BIAS Input (Pin 9)
Receive (see Figure 12)	Low insertion loss	High isolation	1 V	-133 mA	28 V	28 V
Transmit (see Figure 12)	High isolation	Low insertion loss	2 V	28 V	-100 mA	-100 mA

Table 6. SKY12210-478LF Evaluation Board Truth Table

Switch State	Path		Control Conditions			
	Antenna-to-Receiver Port	Transmitter-to-Antenna Port	Antenna Port Bias Input	Receiver Output Port	Transmitter Port Bias Input	RX_BIAS Input
Receive (see Figure 12)	Low insertion loss	High isolation	5 V	0 V (ground)	28 V	28 V
Transmit (see Figure 12)	High isolation	Low insertion loss	5 V	28 V	0 V (ground)	0 V (ground)

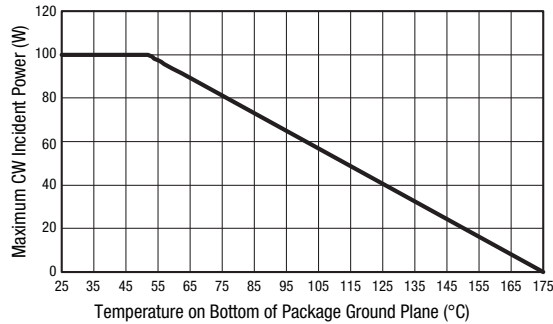

Figure 10. Transmit Power Derating, Maximum CW Incident Power (Frequency = 2.6 GHz) vs Ground Plane Temperature

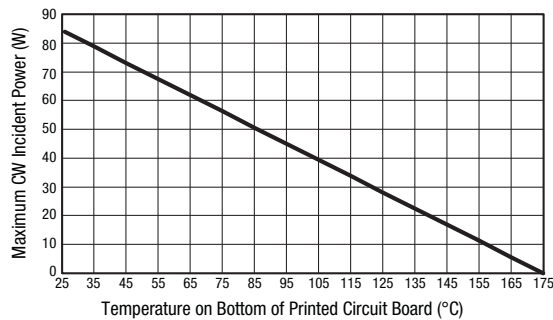

Figure 11. Transmit Power Derating, Maximum CW Incident Power (Frequency = 2.6 GHz) vs Printed Circuit Board Temperature

Evaluation Board Description

The SKY12210-478LF Evaluation Board is used to test the performance of the SKY12210-478LF PIN Diode SPDT switch. An assembly drawing for the Evaluation Board is shown in Figure 13. The layer detail physical characteristics are provided in Figure 14.

The SKY12210-478LF is designed to handle very large signals. Sufficient power may be dissipated by this switch to cause heating of the PIN diodes contained in the switch. It is very important to use a printed circuit board design that provides adequate cooling capability to keep the junction temperature of the PIN diodes below their maximum rated operating temperature.

As indicated in Figure 10, the x-axis temperature is referenced to the bottom of the QFN package. A printed circuit board with a very low thermal resistance and external heat sink design must be used to achieve the results shown in this Figure. The power derating curve with the x-axis temperature referenced to the bottom of the printed circuit board is provided in Figure 11.

The evaluation circuit is designed to facilitate control of the SKY12210-478LF transmit/receive switch with bias signals derived from positive voltages. The state of the PIN diodes within the SKY12210-478LF is controlled with 5 V applied to the ANT port and bias voltages of either 28 V or 0 V applied to the

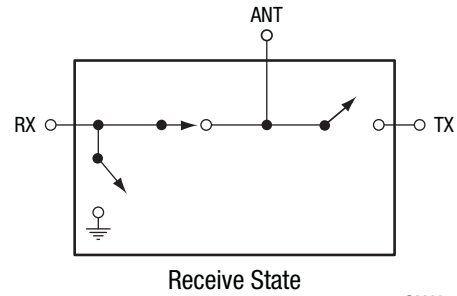
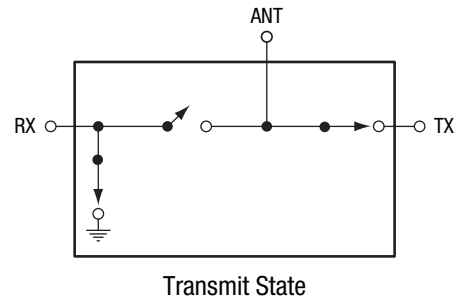

S2398

Figure 12. SKY12210-478LF Equivalent Circuit Diagrams

remaining bias inputs (RX and TX ports). The switch state circuit diagrams are shown in Figure 12.

The value of resistor R1, 31 Ω, is selected to provide 100 mA of forward current through the "on" series diode with 5 V applied to the ANT port bias pin. The R2 resistance value of 262 Ω is selected to produce approximately 100 mA of forward bias current in the RX shunt diode with a source voltage of 28 V.

The magnitudes of the voltages applied to the TX and RX ports determine which of the RX or TX series diodes is biased into forward conduction. For example, to place the SKY12210-478LF into the transmit state, 0 V is applied to the TX port (which forward biases the diode between pins 2 and 14), 28 V is applied to the RX port (which reverse biases the diode between pins 2 and 7), and 0 V is applied to the RX_BIAS port (which applies a forward bias through R2 to the diode connected between pins 7 and 9).

The component values shown in the Evaluation Board circuit diagram (Figure 15) were selected to optimize performance in the 2.0 to 3.5 GHz band.

Refer to Table 7 for the Evaluation Board Bill of Materials. Table 8 provides voltage, current, and resistor values for bias adjustments.

Package Dimensions

The PCB layout footprint for the SKY12210-478LF is shown in Figure 16. Typical case markings are noted in Figure 17. Package dimensions for the 16-pin QFN are shown in Figure 18, and tape and reel dimensions are provided in Figure 19.

Package and Handling Information

Instructions on the shipping container label regarding exposure to moisture after the container seal is broken must be followed. Otherwise, problems related to moisture absorption may occur

when the part is subjected to high temperature during solder assembly.

The SKY12210-478LF is rated to Moisture Sensitivity Level 1 (MSL1) at 260 °C. It can be used for lead or lead-free soldering. For additional information, refer to the Skyworks Application Note, *Solder Reflow Information*, document number 200164.

Care must be taken when attaching this product, whether it is done manually or in a production solder reflow environment. Production quantities of this product are shipped in a standard tape and reel format.

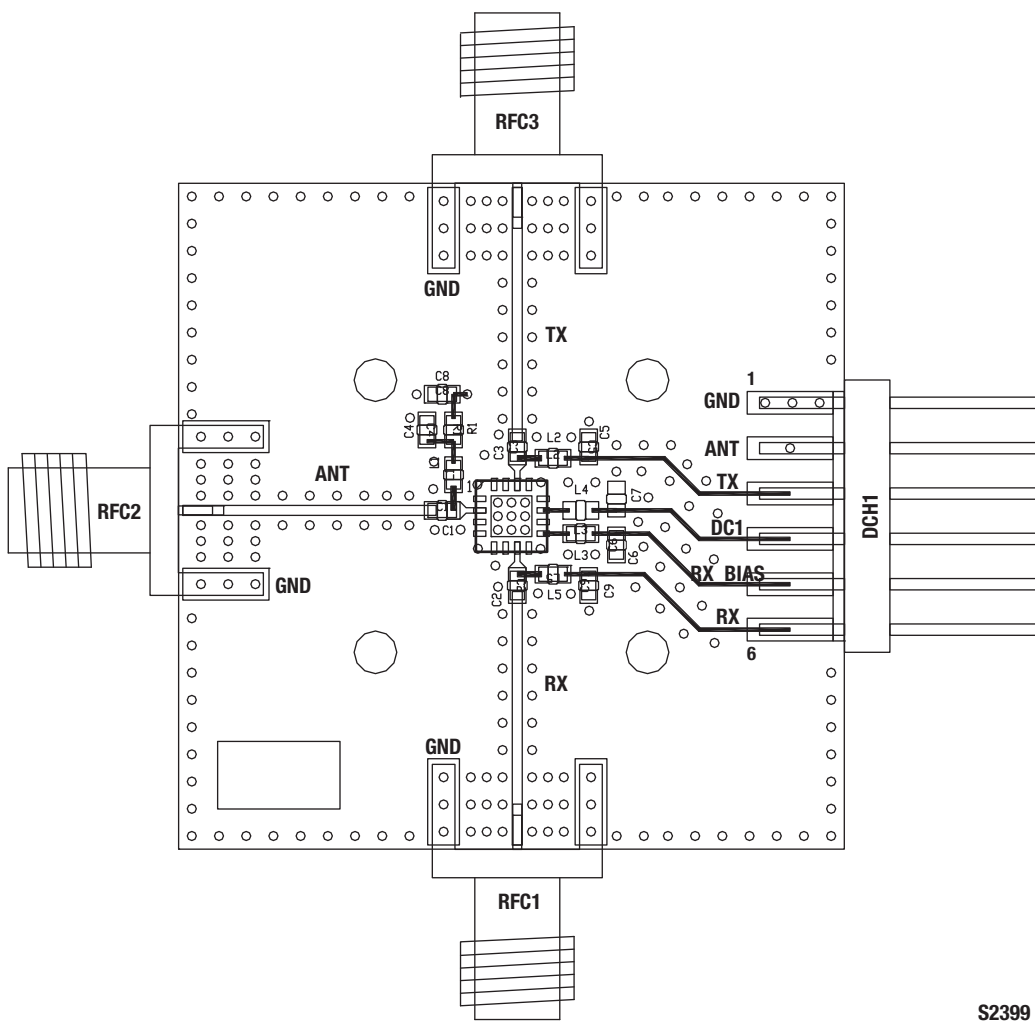

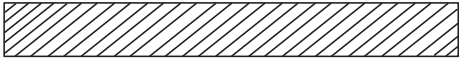



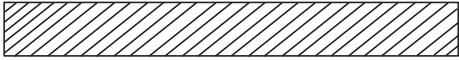



Figure 13. SKY12210-478LF Evaluation Board Assembly Diagram

S2399

Cross Section	Name	Thickness (in)	Material
	Top Soldermask		
	L1	(0.0028)	Cu foil
	Laminate	0.012 ± 0.0006	Rogers R04003C Core
	L2	(0.0014)	Cu foil
	Laminate	(Note 1)	FR4 Prepreg
	L3	(0.0014)	Cu foil
	Laminate	0.010 ± 0.0006	FR4 Core
	L4	(0.0028)	Cu foil
	Bottom Soldermask		

Note 1: Adjust this thickness to meet total thickness goal of 0.062 ± 0.005 inches.

S2531

Figure 14. Layer Detail Physical Characteristics

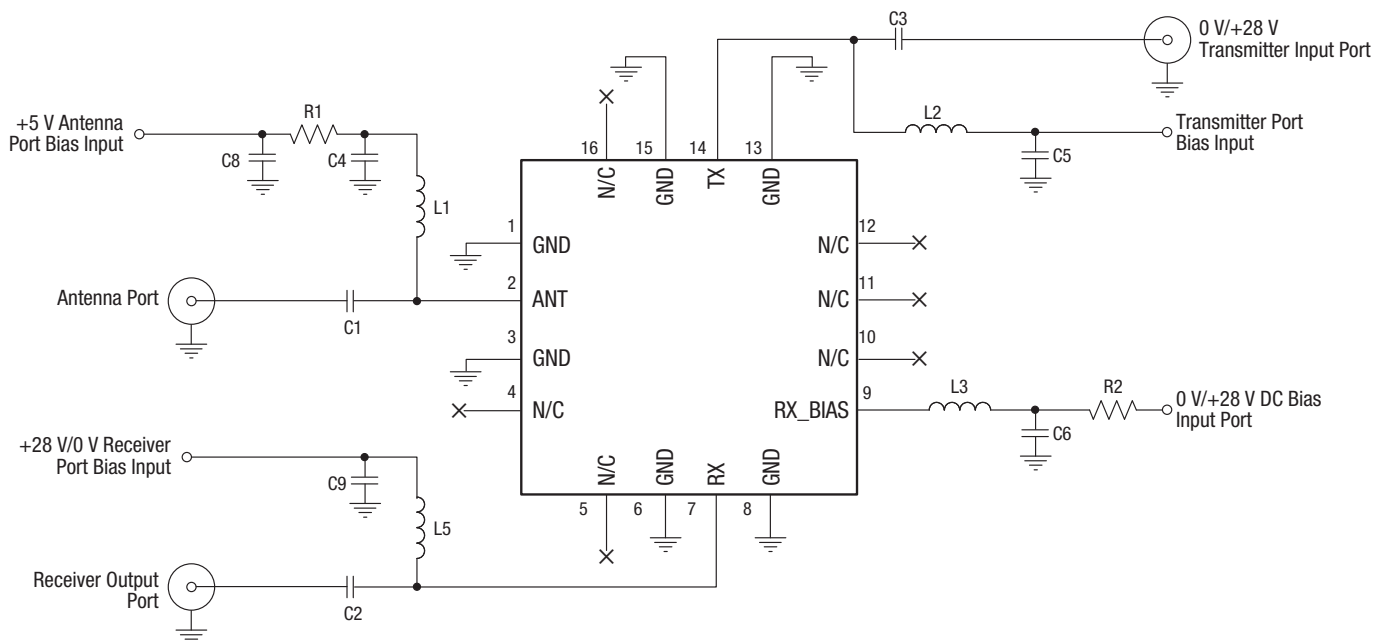

NOTE: The N/C pins (4, 5, 10, 11, 12, and 16) are not internally connected, so they can be left open or grounded.

S2402

Figure 15. Evaluation Board Schematic

Table 7. Evaluation Board Bill of Materials (Note 1)

Component	Value	Size	Manufacturer	Mfr Part Number	Characteristics
C1, C2, C3, C4, C5, C6, C9	1000 pF	0603	TDK	C1608C0G1H102JT	COG, 50 V, ±5%
C8	1 μF	0603	TDK	C2012X7R1H104K	X7R, 50 V, ±10%
L1, L2, L5	22 nH	0603	Taiyo-Yuden	HK160822NJ-T	SRF, 1600 MHz, ±5%
L3	560 nH	0603	Coil Craft	0603LS-561XJLB	SRF, 525 MHz, ±5%
R1 (Note 2)	62 Ω	0603	Panasonic	ERJ-3GEYJ620V	0.2 W, ±5%
R2 (Note 3)	262 Ω	–	–	–	Axial leaded (off board)

Note 1: Component values selected are based on the desired frequency and bias level. Values may be adjusted for a specific response.

Note 2: Two 62 Ω resistors are combined in parallel to achieve a minimum power handling requirement and 31 Ω resistance.

Note 3: Evaluation Board does not include resistor R2. Operating at 28 V and 100 mA requires resistor R2 with a power dissipation greater than 2.7 W.

Table 8. Component Calculation Values

Vs (V)	V _{DIODE} (V)	V _{RES} (V)	Current (A)	Resistance (Ω)	Power Dissipation (W)
28	1	27	0.10	262	2.7
5	2	3	0.10	30	0.3

Notes: Vs = supply voltage; V_{DIODE} = voltage drop across the diode; V_{RES} = voltage drop across the resistor.

R1 and R2 values are calculated by $(V_s - V_{DIODE})/I$, where I is the desired bias current.

The power dissipation in R1 or R2 is calculated by $I \times (V_s - V_{DIODE})$. The resistor selected must be safely rated with a power greater than the dissipated power.

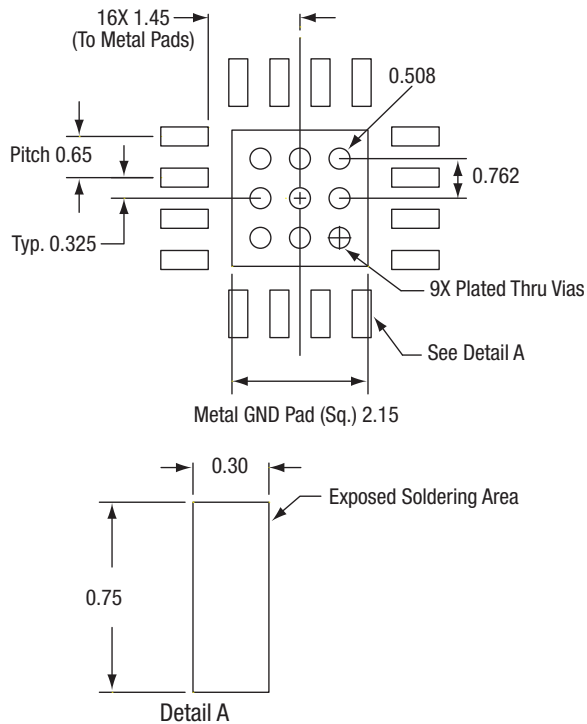

All measurements in millimeters

S2274

Figure 16. SKY12210-478LF PCB Layout Footprint

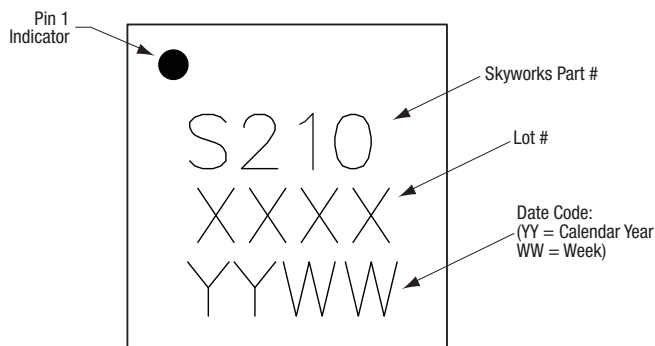
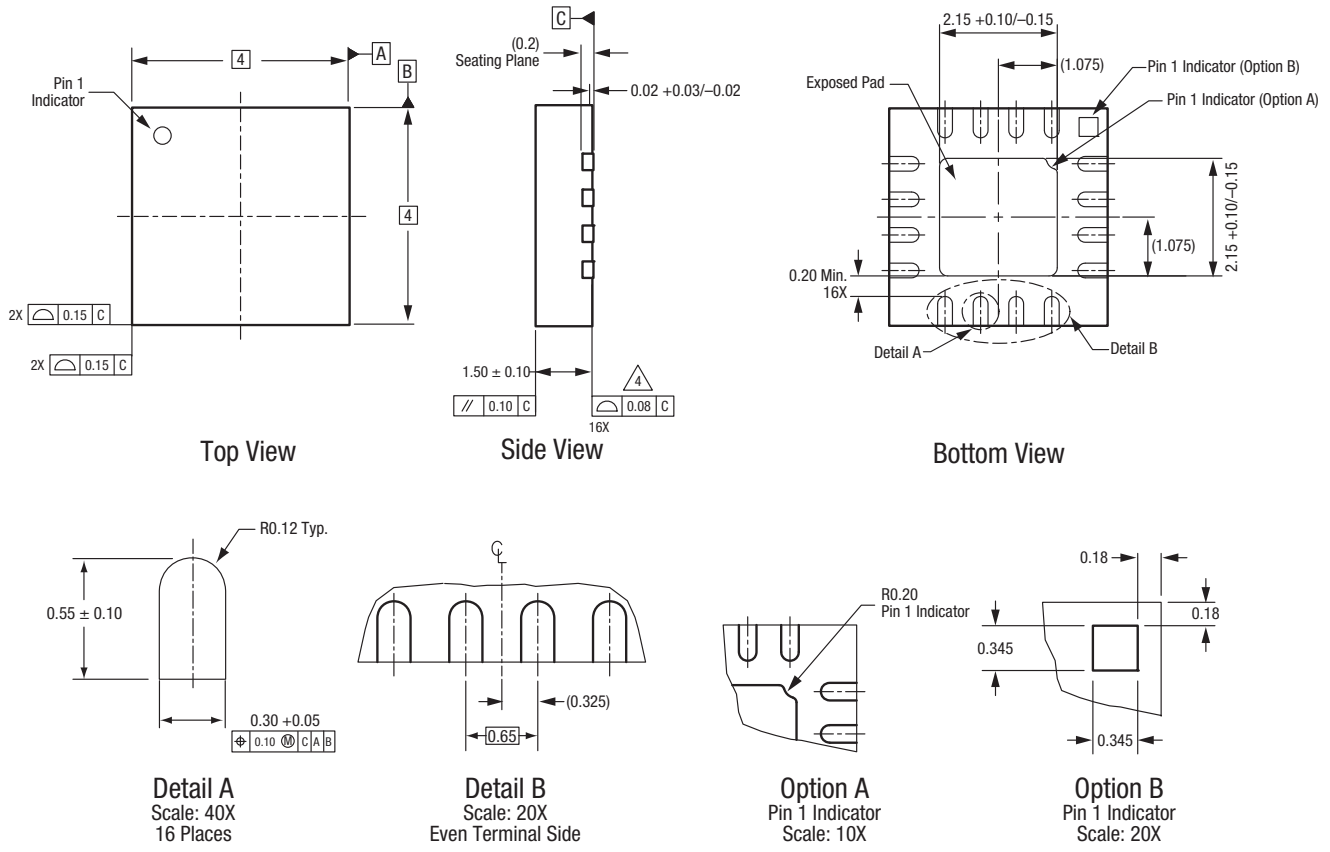

Figure 17. Typical Case Markings



All measurements are in millimeters.
 Dimensioning and tolerancing according to ASME Y14.5M-1994.
 Coplanarity applies to the exposed heat sink slug as well as the terminals.
 Package may have option A or option B pin 1 indicator.

S2400a

Figure 18. SKY12210-478LF 16-Pin QFN Package Dimensions

Ordering Information

Model Name	Manufacturing Part Number	Evaluation Board Part Number
SKY12210-478LF: PIN Diode SPDT Switch	SKY12210-478LF	SKY12210-478LF-EVB

Copyright © 2011-2014 Skyworks Solutions, Inc. All Rights Reserved.

Information in this document is provided in connection with Skyworks Solutions, Inc. (“Skyworks”) products or services. These materials, including the information contained herein, are provided by Skyworks as a service to its customers and may be used for informational purposes only by the customer. Skyworks assumes no responsibility for errors or omissions in these materials or the information contained herein. Skyworks may change its documentation, products, services, specifications or product descriptions at any time, without notice. Skyworks makes no commitment to update the materials or information and shall have no responsibility whatsoever for conflicts, incompatibilities, or other difficulties arising from any future changes.

No license, whether express, implied, by estoppel or otherwise, is granted to any intellectual property rights by this document. Skyworks assumes no liability for any materials, products or information provided hereunder, including the sale, distribution, reproduction or use of Skyworks products, information or materials, except as may be provided in Skyworks Terms and Conditions of Sale.

THE MATERIALS, PRODUCTS AND INFORMATION ARE PROVIDED “AS IS” WITHOUT WARRANTY OF ANY KIND, WHETHER EXPRESS, IMPLIED, STATUTORY, OR OTHERWISE, INCLUDING FITNESS FOR A PARTICULAR PURPOSE OR USE, MERCHANTABILITY, PERFORMANCE, QUALITY OR NON-INFRINGEMENT OF ANY INTELLECTUAL PROPERTY RIGHT; ALL SUCH WARRANTIES ARE HEREBY EXPRESSLY DISCLAIMED. SKYWORKS DOES NOT WARRANT THE ACCURACY OR COMPLETENESS OF THE INFORMATION, TEXT, GRAPHICS OR OTHER ITEMS CONTAINED WITHIN THESE MATERIALS. SKYWORKS SHALL NOT BE LIABLE FOR ANY DAMAGES, INCLUDING BUT NOT LIMITED TO ANY SPECIAL, INDIRECT, INCIDENTAL, STATUTORY, OR CONSEQUENTIAL DAMAGES, INCLUDING WITHOUT LIMITATION, LOST REVENUES OR LOST PROFITS THAT MAY RESULT FROM THE USE OF THE MATERIALS OR INFORMATION, WHETHER OR NOT THE RECIPIENT OF MATERIALS HAS BEEN ADVISED OF THE POSSIBILITY OF SUCH DAMAGE.

Skyworks products are not intended for use in medical, lifesaving or life-sustaining applications, or other equipment in which the failure of the Skyworks products could lead to personal injury, death, physical or environmental damage. Skyworks customers using or selling Skyworks products for use in such applications do so at their own risk and agree to fully indemnify Skyworks for any damages resulting from such improper use or sale.

Customers are responsible for their products and applications using Skyworks products, which may deviate from published specifications as a result of design defects, errors, or operation of products outside of published parameters or design specifications. Customers should include design and operating safeguards to minimize these and other risks. Skyworks assumes no liability for applications assistance, customer product design, or damage to any equipment resulting from the use of Skyworks products outside of stated published specifications or parameters.

Skyworks and the Skyworks symbol are trademarks or registered trademarks of Skyworks Solutions, Inc., in the United States and other countries. Third-party brands and names are for identification purposes only, and are the property of their respective owners. Additional information, including relevant terms and conditions, posted at www.skyworksinc.com, are incorporated by reference.



Стандарт Электрон Связь

Мы молодая и активно развивающаяся компания в области поставок электронных компонентов. Мы поставляем электронные компоненты отечественного и импортного производства напрямую от производителей и с крупнейших складов мира.

Благодаря сотрудничеству с мировыми поставщиками мы осуществляем комплексные и плановые поставки широчайшего спектра электронных компонентов.

Собственная эффективная логистика и склад в обеспечивает надежную поставку продукции в точно указанные сроки по всей России.

Мы осуществляем техническую поддержку нашим клиентам и предпродажную проверку качества продукции. На все поставляемые продукты мы предоставляем гарантию .

Осуществляем поставки продукции под контролем ВП МО РФ на предприятия военно-промышленного комплекса России , а также работаем в рамках 275 ФЗ с открытием отдельных счетов в уполномоченном банке. Система менеджмента качества компании соответствует требованиям ГОСТ ISO 9001.

Минимальные сроки поставки, гибкие цены, неограниченный ассортимент и индивидуальный подход к клиентам являются основой для выстраивания долгосрочного и эффективного сотрудничества с предприятиями радиоэлектронной промышленности, предприятиями ВПК и научно-исследовательскими институтами России.

С нами вы становитесь еще успешнее!

Наши контакты:

Телефон: +7 812 627 14 35

Электронная почта: sales@st-electron.ru

Адрес: 198099, Санкт-Петербург,
Промышленная ул, дом № 19, литера Н,
помещение 100-Н Офис 331