

# FRDM-KL05Z User's Manual

2013-01-29

Rev. 1.0

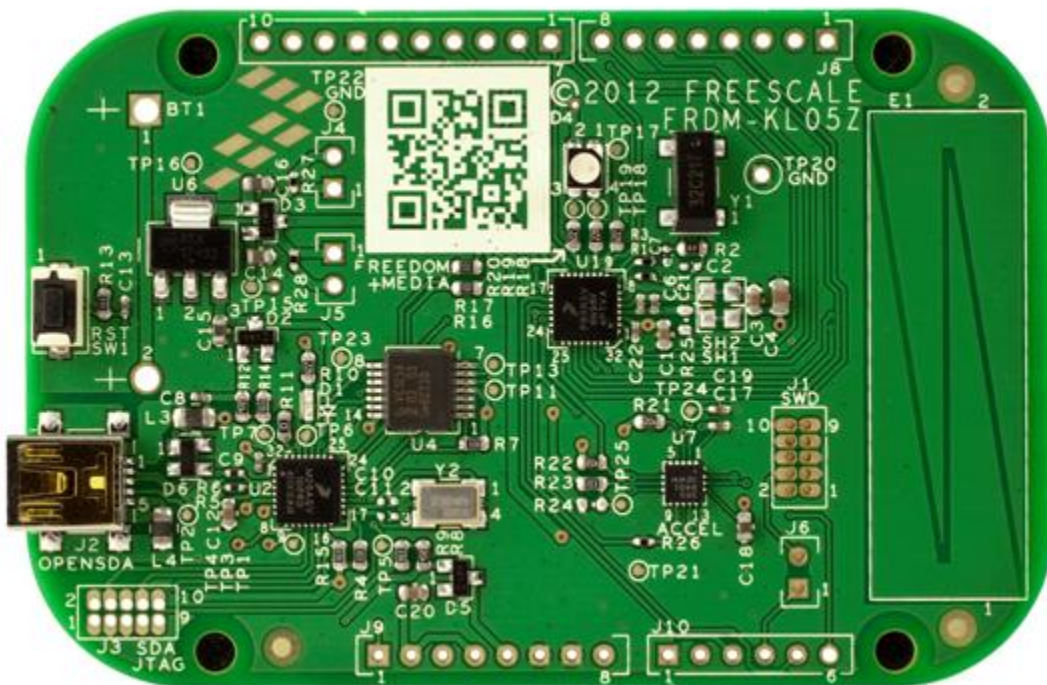

---

# Table of Contents

<b>1 Overview</b> .....	<b>3</b>
<b>2 Reference Documents</b> .....	<b>3</b>
<b>3 Getting Started</b> .....	<b>3</b>
<b>4 FRDM-KL05Z Hardware Overview</b> .....	<b>4</b>
<b>5 FRDM-KL05Z Hardware Description</b> .....	<b>5</b>
5.1 Power Supply.....	5
5.2 Serial and Debug Adapter (OpenSDA) .....	7
5.2.1 Debug Interface.....	7
5.2.2 Virtual Serial Port.....	8
5.3 KL05Z Microcontroller .....	8
5.3.1 Clock Source .....	9
5.3.2 Serial Port.....	9
5.3.3 Reset.....	9
5.3.4 Debug.....	9
5.4 Capacitive Touch Slider.....	10
5.5 3-axis Accelerometer.....	10
5.6 RGB LED.....	10
5.7 Input/Output Connectors.....	11
5.8 Arduino Compatibility .....	12

## 1 Overview

The Freescale Freedom development platform is a set of software and hardware tools for evaluation and development. It is ideal for rapid prototyping of microcontroller-based applications. The Freescale Freedom KL05Z hardware, FRDM-KL05Z, is a simple, yet sophisticated design featuring a Kinetis L series microcontroller, the industry's first microcontroller built on the ARM® Cortex™-M0+ core.

FRDM-KL05Z can be used to evaluate the KL04 and KL05 Kinetis L series devices. It features a MKL05Z32VFM4, a KLO family device boasting a max operating frequency of 48MHz, 32KB of flash, and a multitude of analog and digital peripherals. The FRDM-KL05Z hardware is form-factor compatible with the Arduino™ R3 pin layout, providing a broad range of expansion board options. The on-board interfaces include an RGB LED, a 3-axis digital accelerometer, and a capacitive touch slider.

The FRDM-KL05Z also features the Freescale open standard embedded serial and debug adapter known as OpenSDA. This circuit offers several options for serial communications, flash programming and run-control debugging.

## 2 Reference Documents

The table below provides a list of reference documents for the FRDM-KL05Z hardware. All of these documents are available online at [www.freescale.com/FRDM-KL05Z](http://www.freescale.com/FRDM-KL05Z).

**Table 1. FRDM-KL05Z Reference Documents**

Filename	Description
<i>FRDM-KL05Z Quick Start Package</i>	Quick Start Guide and supporting files for getting started with the FRDM-KL05Z.
<i>FRDM-KL05Z User's Manual</i>	This document—overview and detailed information for the FRDM-KL05Z hardware.
<i>FRDM-KL05Z Pinouts</i>	Spreadsheet of pin connections for all MCU pins. Includes pinout for the I/O headers, Arduino R3 compatibility chart, and OpenSDA MCU pinout.
<i>FRDM-KL05Z Schematics</i>	PDF schematics for the FRDM-KL05Z hardware
<i>FRDM-KL05Z Design Package</i>	Zip file containing all design source files for the FRDM-KL05Z hardware
<i>OpenSDA User's Guide</i>	Overview and instructions for use of the OpenSDA embedded debug circuit

## 3 Getting Started

Refer to the *FRDM-KL05Z Quick Start Package* for step-by-step instructions for getting started with the FRDM-KL05Z. See the **Jump Start Your Design** section on [www.freescale.com/FRDM-KL05Z](http://www.freescale.com/FRDM-KL05Z) for the Quick Start Package and software lab guides.

## 4 FRDM-KL05Z Hardware Overview

The FRDM-KL05Z includes:

- MKL05Z32VFM4 in a 32 QFN package
- Capacitive touch slider
- MMA8451Q accelerometer
- Tri-color (RGB) LED
- Flexible power supply options – USB, coin cell battery, external source
- Battery-ready, power-measurement access points
- Easy access to MCU I/O via Arduino™ R3 compatible I/O connectors
- Programmable OpenSDA debug interface with multiple applications available including:
  - Mass storage device flash programming interface
  - P&E Debug interface, which provides run-control debugging and compatibility with IDE tools
  - CMSIS-DAP interface (new ARM standard for embedded debug interface)
  - Data logging application

Figure 1 shows a block diagram of the FRDM-KL05Z design. The primary components and their placement on the hardware assembly are pointed out in Figure 2.

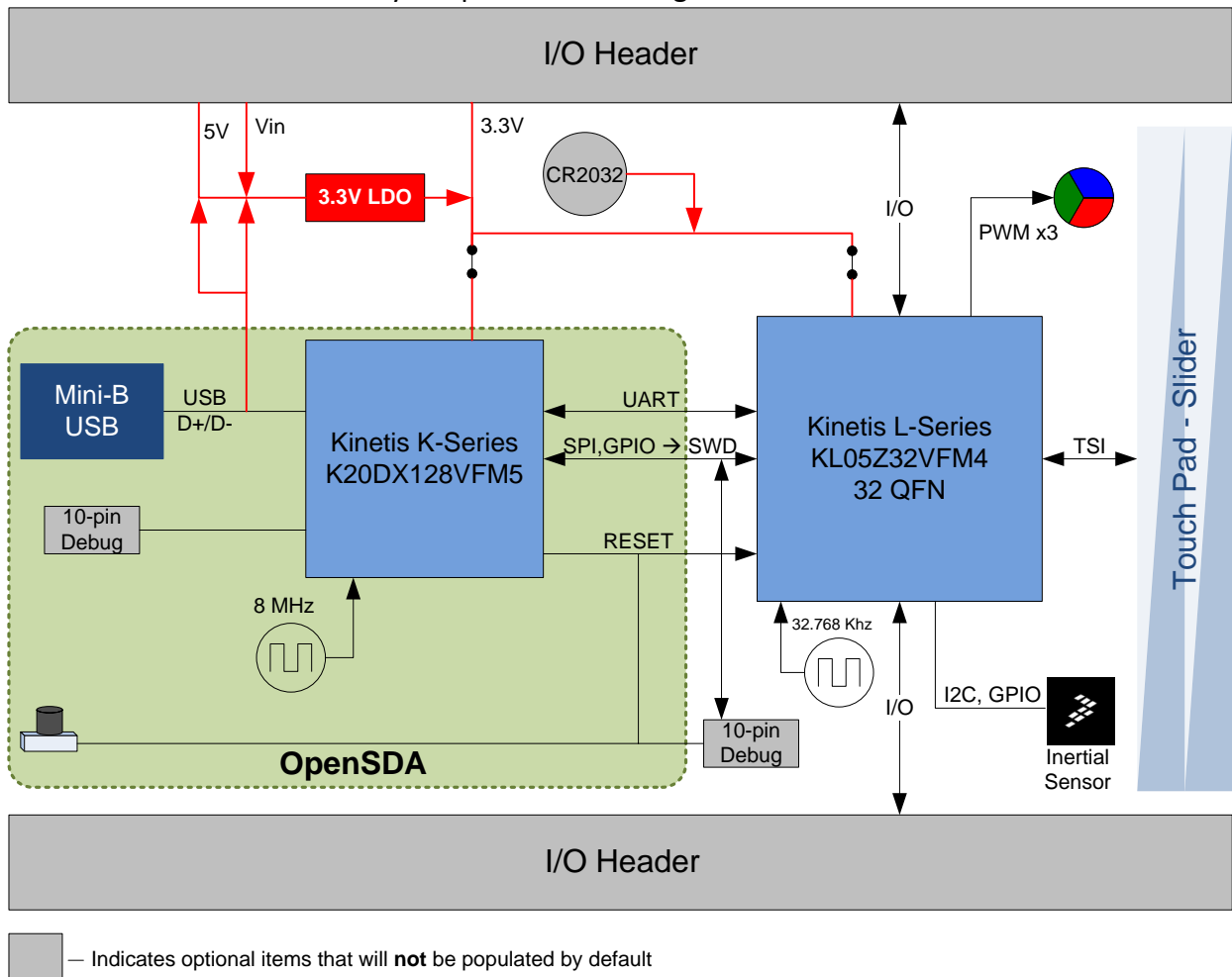

**Figure 1. FRDM-KL05Z Block Diagram**

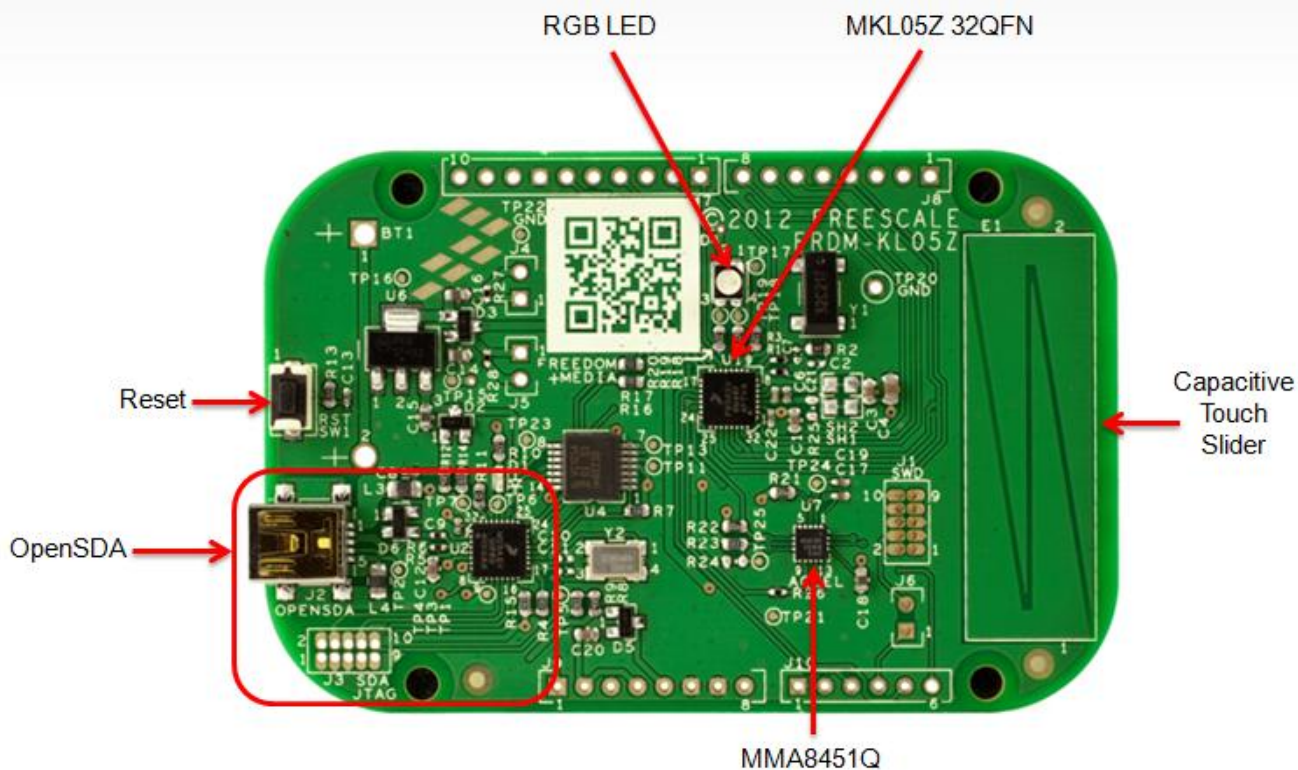

Figure 2. FRDM-KL05Z Feature Call-outs

## 5 FRDM-KL05Z Hardware Description

### 5.1 Power Supply

There are multiple power supply options on the FRDM-KL05Z. It can be powered from the USB connector, the  $V_{IN}$  pin on the I/O header, an on-board coin cell battery, or an off-board 1.71-3.6V supply from the 3.3V pin on the I/O header. The USB and  $V_{IN}$  supplies are regulated on-board using a 3.3V linear regulator to produce the main power supply. The other two sources are not regulated on-board. Table 2 provides the operational details and requirements for the power supplies.

Table 2. Power Supply Requirements

Supply Source	Valid Range	OpenSDA Operational?	Regulated on-board?
OpenSDA USB (J2)	5V	Yes	Yes
$V_{IN}$ Pin	4.3-9V	No	Yes
3.3V Pin	1.71-3.6V	No	No
Coin Cell Battery	1.71-3.6V	No	No

Note that the OpenSDA circuit is only operational when a USB cable is connected and supplying power to J2. However, protection circuitry is in place to allow multiple sources to be powered at once.

Figure 3 shows the schematic drawing for the power supply inputs and the on-board voltage regulator.

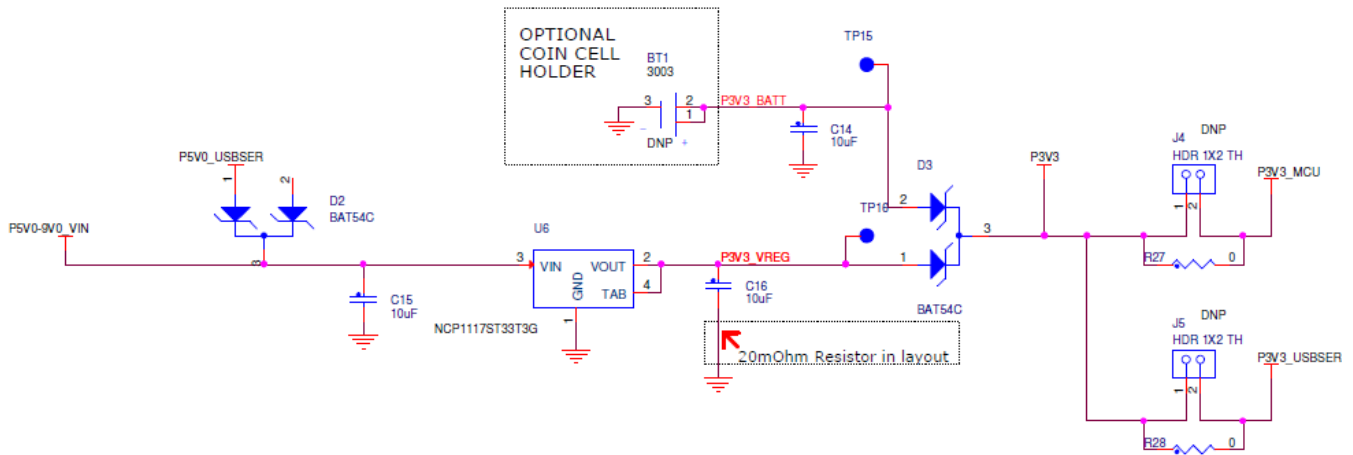

**Figure 3. Power Supply Schematic**

**Table 3. FRDM-KL05Z Power Supplies**

Power Supply Name	Description
P5-9V_VIN	Power supplied from the <b>V<sub>IN</sub></b> pin of the I/O headers (J9 pin 8).
P5V_SDA	Power supplied from the <b>OpenSDA USB</b> connector (J2). A Schottky diode provides back drive protection.
P3V3_VREG	<b>Regulated 3.3V supply.</b> Sources power to the P3V3 supply rail through a back drive protection Schottky diode. <sup>1</sup>
P3V3_BATT	<b>Coin cell battery supply voltage.</b> Sources power to the P3V3 supply rail through a back drive protection Schottky diode.
P3V3	<b>Main supply rail</b> for the FRDM-KL05Z assembly. May be sourced from P3V3_VREG, P3V3_BATT, or directly from the I/O headers (J9 pin 2)
P3V3_MCU	<b>KL05Z MCU supply.</b> Header J4 provides a convenient means for energy consumption measurements. <sup>2</sup>
P3V3_USBSER	<b>OpenSDA circuit supply.</b> Header J5 provides a convenient means for energy consumption measurements. <sup>2</sup>
P5V_USB	Nominal <b>5V supplied to the I/O headers</b> (J9 pin 5). Sourced from P5V_SDA supply through a back drive protection Schottky diode.

**NOTES:**

- 1) By default the linear regulator, U6, is a 3.3V output regulator. However, this is a common footprint that would allow the user to modify the assembly to utilize an alternative device such as a 1.8V or 2.5V regulator. The KL05Z microcontroller has an operating range of 1.71V to 3.6V.
- 2) J4 and J5 are not populated by default. The two pins of these headers are shorted together by a 0ohm resistor on the top layer of the PCB. To measure the energy consumption of either the KL05Z or the OpenSDA MCU, the resistor between these pins must first be removed. A current probe or a shunt resistor and volt meter can then be applied to measure the energy consumption on these rails.



## 5.2 Serial and Debug Adapter (OpenSDA)

OpenSDA is an open-standard serial and debug adapter. It bridges serial and debug communications between a USB host and an embedded target processor as shown in Figure 4. The hardware circuit is based on a Freescale Kinetis K20 family microcontroller (MCU) with 128 KB of embedded flash and an integrated USB controller. OpenSDA features a mass storage device (MSD) bootloader, which provides a quick and easy mechanism for loading different OpenSDA Applications such as flash programmers, run-control debug interfaces, serial-to-USB converters, and more. Refer to the *OpenSDA User's Guide* for more details.

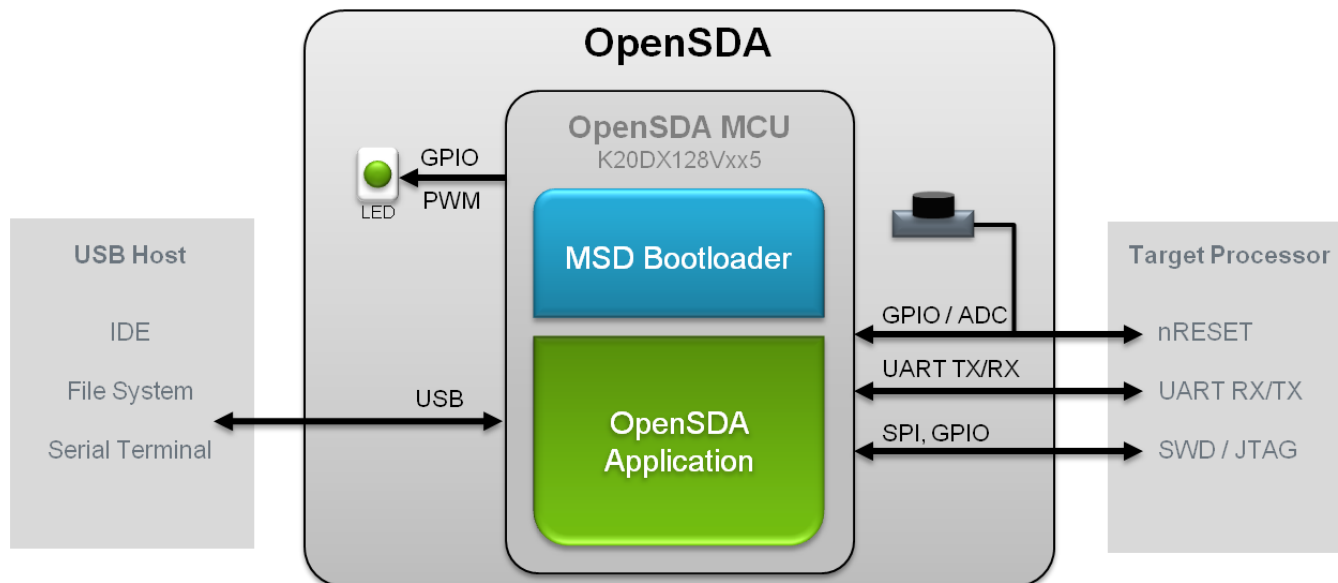

**Figure 4. OpenSDA High-Level Block Diagram**

The OpenSDA circuit includes a status LED (D1) and a pushbutton (SW1). The pushbutton asserts the Reset signal to the KL05Z target MCU. It can also be used to place the OpenSDA circuit into Bootloader mode. SPI and GPIO signals provide an interface to the SWD debug port of the KL05Z. Additionally, signal connections are available to implement a UART serial channel. The OpenSDA circuit receives power when the USB connector, J2, is plugged into a USB host.

### 5.2.1 Debug Interface

Signals with SPI and GPIO capability are used to connect directly to the SWD of the KL05Z. These signals are also brought out to a standard 10-pin (0.05") Cortex Debug connector (J1). It is possible to isolate the KL05Z MCU from the OpenSDA circuit and use J1 to connect to an off-board MCU. To accomplish this, cut the trace on the bottom side of the PCB that connects J6 pin 1 to J6 pin 2. This will disconnect the SWD\_CLK pin to the KL05Z so that it will not interfere with the communications to an off-board MCU connected to J1.

## SWD CONNECTOR

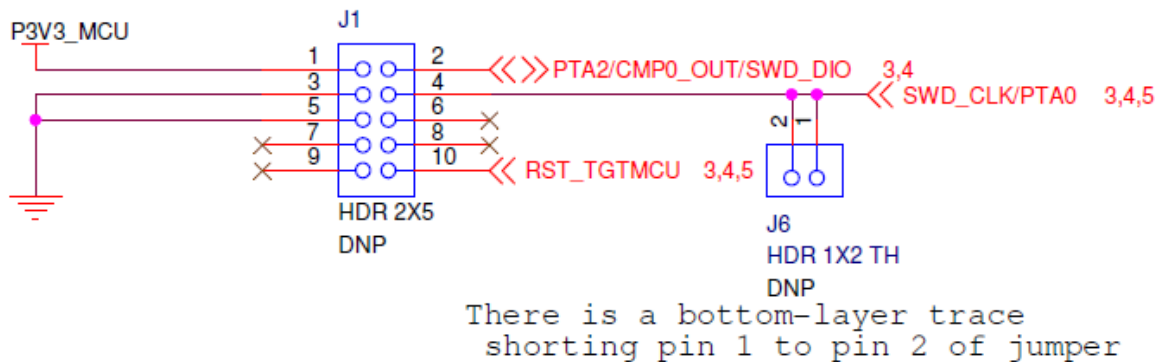

**Figure 5. SWD Debug Connector**

Note that J1 is not-populated by default. A Samtec FTSH-105-02-F-D or compatible connector can be added to the J1 through-hole connector. A mating cable, such as a Samtec FFSD IDC cable, can then be used to connect from the OpenSDA of the FRDM-KL05Z to an off-board SWD connector.

### 5.2.2 Virtual Serial Port

A serial port connection is available between the OpenSDA MCU and the KL05Z through pins PTB1 and PTB2. Several of the default OpenSDA Applications provided by Freescale, including the MSD Flash Programmer and the P&E Debug Application, provide a USB Communications Device Class (CDC) interface that bridges serial communications between the USB host and this serial interface on the KL05Z.

## 5.3 KL05Z Microcontroller

The target microcontroller of the FRDM-KL05Z is the MKL05Z32VFM4, a Kinetis L series device in a 32 QFN package. The KL05Z MCU features include:

- 32-bit ARM Cortex-M0+ core
  - up to 48 MHz operation
  - Single-cycle fast I/O access port
- Memories
  - 32 KB flash
  - 4KB SRAM
- System integration
  - Power management and mode controllers
  - Low-leakage wakeup unit
  - Bit manipulation engine for read-modify-write peripheral operations
  - Direct memory access (DMA) controller
  - Computer operating properly (COP) Watchdog timer
- Clocks
  - Clock generation module with FLL for system and CPU clock generation
  - 4 MHz and 32 kHz internal reference clock



- System oscillator supporting external crystal or resonator
- Low-power 1kHz RC oscillator for RTC and COP watchdog
- Analog peripherals
  - 12-bit SAR ADC w/ DMA support
  - 12-bit DAC w/ DMA support
  - High speed comparator
- Communication peripherals
  - one 8-bit Serial Peripheral Interfaces (SPI)
  - one I<sup>2</sup>C modules
  - One low-power UART
- Timers
  - One 6-channel Timer/PWM module
  - one 2-channel Timer/PWM modules
  - 2-channel Periodic Interrupt Timer (PIT)
  - Real time clock (RTC)
  - Low-power Timer (LPT)
  - System tick timer
- Human-Machine Interfaces (HMI)
  - General purpose input/output controller
  - Capacitive touch sense input interface hardware module

### 5.3.1 Clock Source

The Kinetis KL0 microcontrollers feature an on-chip oscillator compatible with three ranges of input crystal or resonator frequencies: 32-40 kHz (low freq. mode), 3-8 MHz (high freq. mode, low range) and 8-32 MHz (high freq. mode, high range). The KL05Z32 on the FRDM-KL05Z is clocked from a 32.768 kHz crystal.

### 5.3.2 Serial Port

The primary serial port interface signals are PTB1 and PTB2. These signals are connected to both the OpenSDA and to I/O connector J8.

### 5.3.3 Reset

The PTA20/RESET signal on the KL05Z32 is connected to pushbutton, SW1, and to the OpenSDA circuit. The reset button can be used to force an external reset event in the target MCU. The reset button can also be used to force the OpenSDA circuit into bootloader mode. Please refer to section 5.2, Serial and Debug Adapter (OpenSDA), for more details.

### 5.3.4 Debug

The sole debug interface on all Kinetis L Series devices is a Serial Wire Debug (SWD) port. The primary controller of this interface on the FRDM-KL05Z is the onboard OpenSDA circuit (see section 5.2). However, an unpopulated 10-pin (0.05") Cortex Debug connector, J1, provides access to the SWD signals. The Samtec FTSH-105-02-F-D or compatible connectors can be added to the J1 through-hole debug connector to allow for an external debug cable to be connected.

## 5.4 Capacitive Touch Slider

Two Touch Sense Input (TSI) signals, TSI0\_CH8 and TSI0\_CH9, are connected to capacitive electrodes configured as a touch slider. Freescale's Touch Sense Software (TSS) provides a software library for implementing the capacitive touch slider.

## 5.5 3-axis Accelerometer

A Freescale MMA8451Q low-power, three-axis accelerometer is interfaced through an I<sup>2</sup>C bus and two GPIO signals as shown in Table 4 below. By default, the I<sup>2</sup>C address is 0x1D (SA0 pulled high).

**Table 4. Accelerometer Signal Connections**

MMA8451Q	KL05Z32
SCL	PTB3
SDA	PTB4
INT1	NC
INT2	PTA10

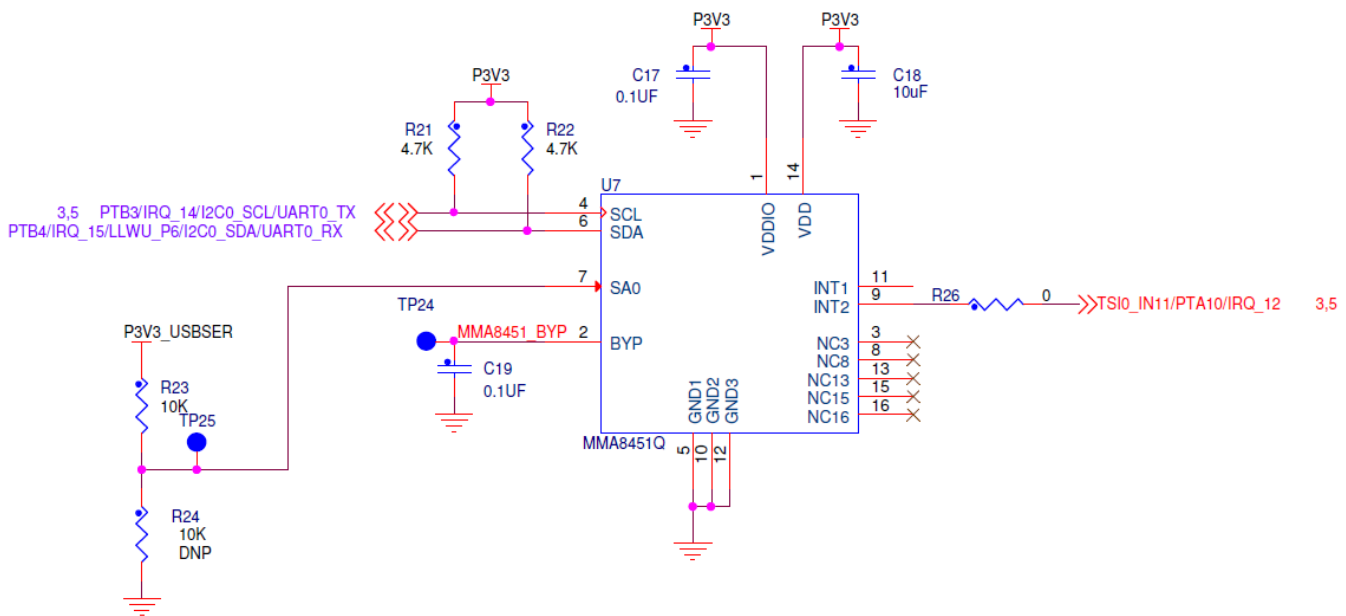

**Figure 6. MMA8451Q Schematic Diagram**

## 5.6 RGB LED

Three PWM-capable signals are connected to a red, green, blue LED, D4. The signal connections are shown in Table 5 below.

**Table 5. RGB LED Signal Connections**

RGB LED	KL05Z32
Red Cathode	PTB8
Green Cathode	PTB9
Blue Cathode	PTB10

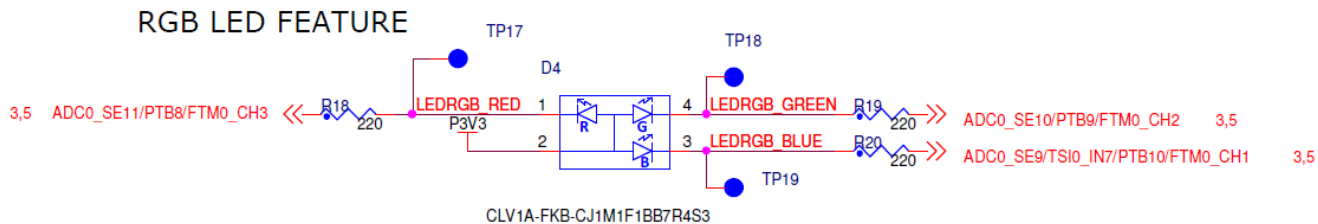
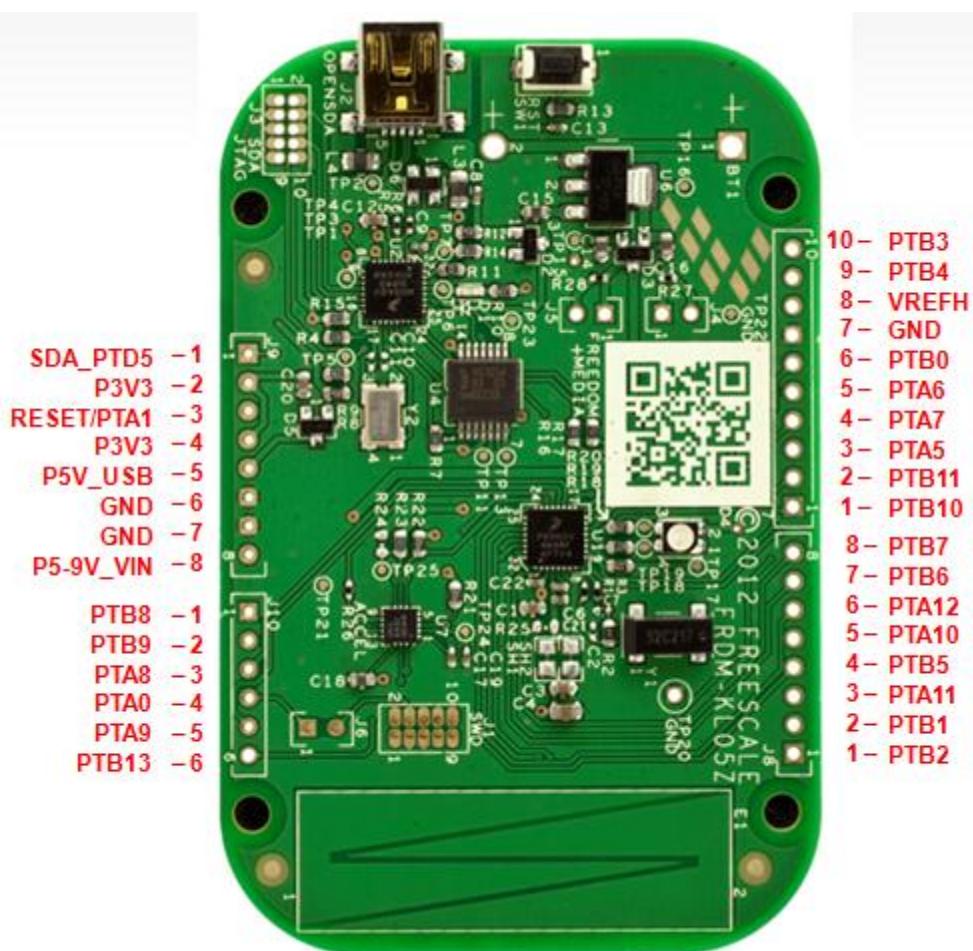

Figure 7. RGB LED Schematic Diagram

## 5.7 Input/Output Connectors

The MKL05Z32VFM4 microcontroller is packaged in a 32-pin QFN. Some pins are utilized in on-board circuitry, but many are directly connected to one of four I/O headers.

The I/O connector pin names are given the same name as the KL05Z GPIO pin name connected to it, where applicable.



Note that all pinout data is available in spreadsheet format in *FRDM-KL05Z Pinouts*. See the Reference Documents section for details.

## 5.8 Arduino Compatibility

The I/O headers on the FRDM-KL05Z are arranged to allow compatibility with peripheral boards (known as shields) that connect to Arduino™ and Arduino-compatible microcontroller boards. The headers share the same mechanical spacing and placement as the I/O headers on the Arduino Revision 3 (R3) standard.

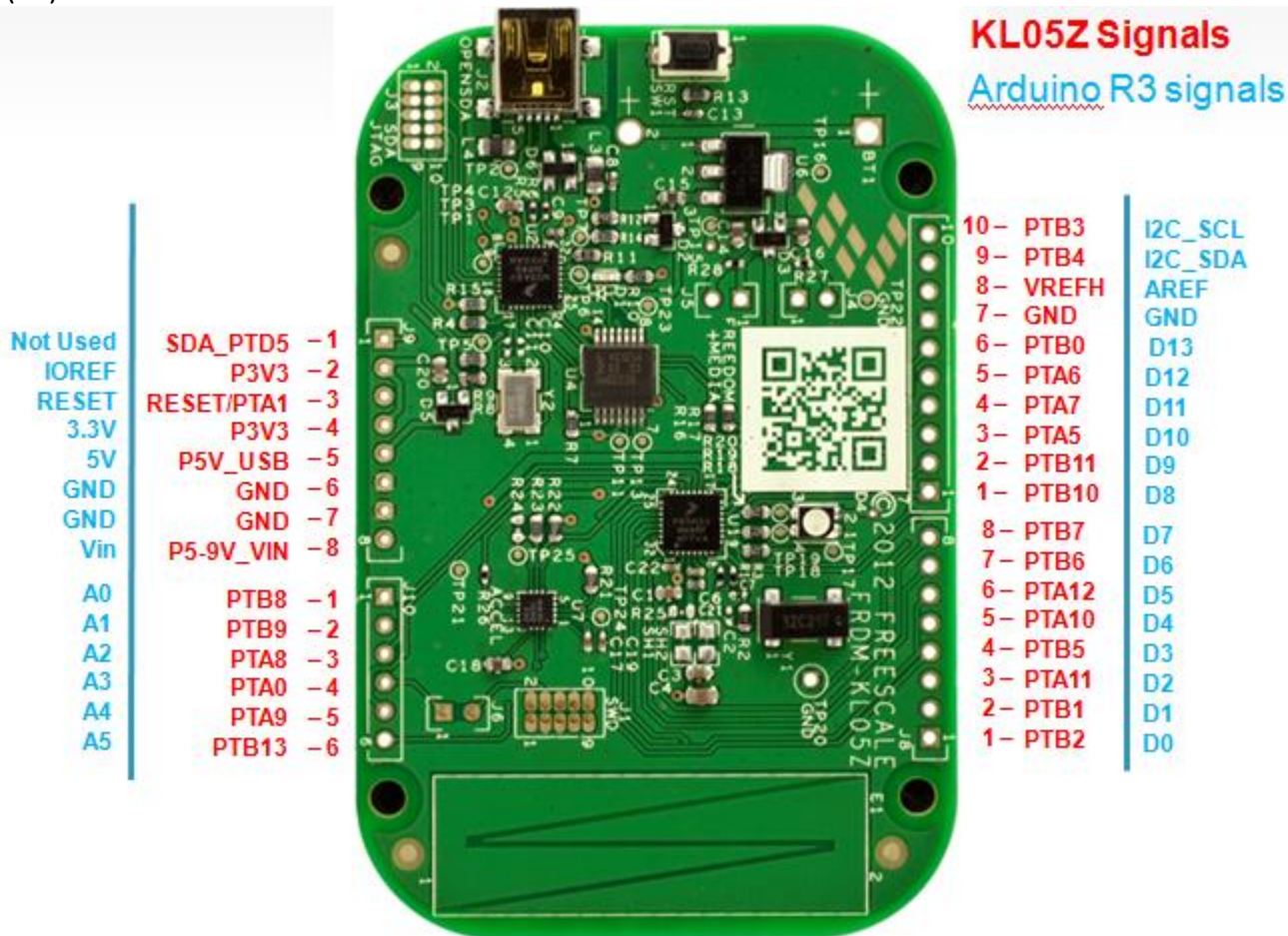

Refer to the *FRDM-KL05Z Pinouts* spreadsheet for a compatibility chart showing how all the functions of the KL05Z signals on the I/O connectors map to the pin functions available on the Arduino Uno R3.

### **How to Reach Us:**

**Home Page:**  
freescale.com

**Web Support:**  
freescale.com/support

Information in this document is provided solely to enable system and software implementers to use Freescale products. There are no express or implied copyright licenses granted hereunder to design or fabricate any integrated circuits or integrated circuits based on the information in this document.

Freescale reserves the right to make changes without further notice to any products herein. Freescale makes no warranty, representation or guarantee regarding the suitability of its products for any particular purpose, nor does Freescale assume any liability arising out of the application or use of any product or circuit, and specifically disclaims any and all liability, including without limitation consequential or incidental damages. "Typical" parameters that may be provided in Freescale data sheets and/or specifications can and do vary in different applications and actual performance may vary over time. All operating parameters, including "Typicals", must be validated for each customer application by customer's technical experts. Freescale does not convey any license under its patent rights nor the rights of others. Freescale sells products pursuant to standard terms and conditions of sale, which can be found at the following address:  
<http://www.reg.net/v2/webservices/Freescale/Docs/TermsandConditions.htm>

Freescale, the Freescale logo, Altivec, C-5, CodeTest, CodeWarrior, ColdFire, C\_Ware, Energy Efficient Solutions logo, Kinetis, mobileGT, PowerQUICC, Processor Expert, QorIQ, Qorriva, StarCore, Symphony, and VortiQa are trademarks of Freescale Semiconductor, Inc., Reg. U.S. Pat. & Tm. Off. Airfast, BeeKit, BeeStack, ColdFire+, CoreNet, Flexis, MadniV, MXC, Platform in a Package, QorIQ Qonverge, QUICC Engine, Ready Play, SafeAssure, SMARTMOS, TurboLink, Vybrid, and Xtrinsic are trademarks of Freescale Semiconductor, Inc. All other product or service names are the property of their respective owners.



© Freescale Semiconductor, Inc. 2012. All rights reserved.

FRDMKL25ZUM  
Rev. 0.90  
2013-01-29





**Стандарт  
Электрон  
Связь**

Мы молодая и активно развивающаяся компания в области поставок электронных компонентов. Мы поставляем электронные компоненты отечественного и импортного производства напрямую от производителей и с крупнейших складов мира.

Благодаря сотрудничеству с мировыми поставщиками мы осуществляем комплексные и плановые поставки широчайшего спектра электронных компонентов.

Собственная эффективная логистика и склад в обеспечивает надежную поставку продукции в точно указанные сроки по всей России.

Мы осуществляем техническую поддержку нашим клиентам и предпродажную проверку качества продукции. На все поставляемые продукты мы предоставляем гарантию .

Осуществляем поставки продукции под контролем ВП МО РФ на предприятия военно-промышленного комплекса России , а также работаем в рамках 275 ФЗ с открытием отдельных счетов в уполномоченном банке. Система менеджмента качества компании соответствует требованиям ГОСТ ISO 9001.

Минимальные сроки поставки, гибкие цены, неограниченный ассортимент и индивидуальный подход к клиентам являются основой для выстраивания долгосрочного и эффективного сотрудничества с предприятиями радиоэлектронной промышленности, предприятиями ВПК и научно-исследовательскими институтами России.

С нами вы становитесь еще успешнее!

**Наши контакты:**

**Телефон:** +7 812 627 14 35

**Электронная почта:** [sales@st-electron.ru](mailto:sales@st-electron.ru)

**Адрес:** 198099, Санкт-Петербург,  
Промышленная ул, дом № 19, литера Н,  
помещение 100-Н Офис 331