

TWR-KL25Z Tower Module

1. TWR-KL25Z

The TWR-KL25Z microcontroller module works either in standalone mode or as part of the NXP Tower System, a modular development platform that enables rapid prototyping and tool re-use through reconfigurable hardware. Take your design to the next level and begin constructing your Tower System today by visiting <http://www.nxp.com/tower> for additional Tower System microcontroller modules and compatible peripherals. For TWR-KL25Z, specific information and updates visit <http://www.nxp.com/TWR-KL25Z48M>.

Contents

1.	TWR-KL25Z	1
2.	Contents	2
3.	TWR-KL25Z Features	2
4.	Get to Know the TWR-KL25Z	3
5.	Reference Documents	4
6.	Hardware Description	4
6.1.	Block diagram	4
6.2.	Microcontroller	5
6.3.	Clocking	5
6.4.	System Power	6
6.5.	Real Time Clock (RTC)	6
6.6.	Debug Interface	6
6.7.	Infrared Port	7
6.8.	Accelerometer	7
6.9.	General Purpose Tower Plug-in (TWRPI) Socket ..	7
6.10.	Potentiometer, Pushbuttons, LEDs	8
6.11.	Touch Interface	8
6.12.	USB	9
7.	TWR-KL25Z Jumper Options	9
8.	Useful Links	11
9.	Revision History	11

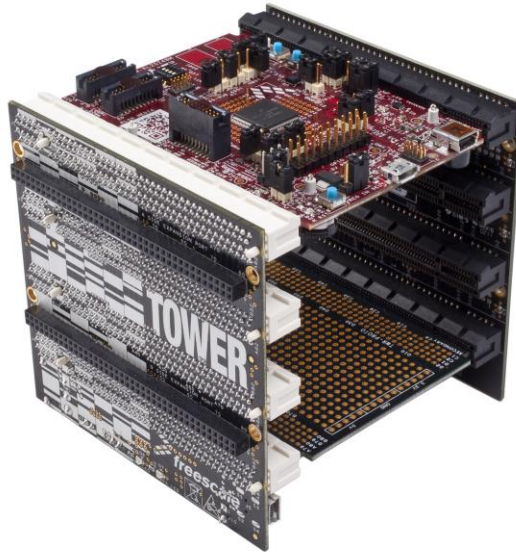

Figure 1. NXP Tower System Overview

2. Contents

The TWR-KL25Z contents include:

- TWR-KL25Z board assembly
- 3ft A to mini-B USB cable for debug interface and power
- Quick Start Guide

3. TWR-KL25Z Features

- Tower compatible microcontroller module
- MKL25Z128VLK4 MCU (48 MHz, 128KB Flash, 16 KB RAM, Low power, 80LQFP package)
- Dual role USB interface with Micro-AB USB connector
- Touch Tower Plug-in Socket
- General purpose Tower Plug-in (TWRPI) socket
- On-board debug circuit MK20 OpenSDA serial debug interface with virtual serial port and mass storage device bootloader
- Three axis accelerometer (MMA8451Q)
- Four (4) user-controllable LEDs
- Two (2) capacitive touch pads
- Two (2) user pushbutton switches

TWR-KL25Z Tower Module, User's Guide, Rev. 1.1, 09/2016

- Infrared transmit and receive
- Potentiometer for ADC measurements
- GPIO header for prototyping

4. Get to Know the TWR-KL25Z

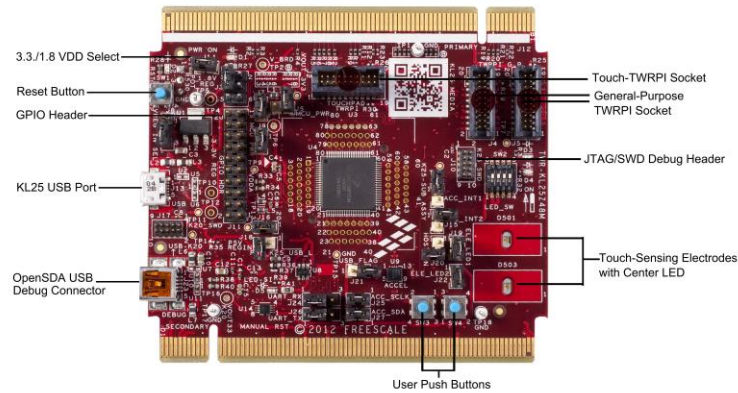

Figure 2. NXP Tower System op Down (Front)



Figure 3. NXP Tower System op Down (Back)

5. Reference Documents

The documents listed below provides more information on the Kinetis family, Tower System, and MCU Modules. The following documents are available here: <http://www.nxp.com/TWR-KL25Z48M> or <http://www.nxp.com/kinetis>.

- TWRKL25ZQSG: Quick Start Guide
- TWR-KL25Z-SCH: Schematics
- TWR-KL25Z-PWA: Design Package
- MKL25Z128VLK4 Reference Manual
- Tower Configuration Tool
- Tower Mechanical Drawing

6. Hardware Description

The TWR-KL25Z is a Tower MCU Module featuring the MKL25Z128VLK4 —a Kinetis microcontroller with USB 2.0 full-speed OTG controllers in an 80 LQFP package. TWR-KL25Z is used in the NXP Tower System but can operate stand-alone. An on-board debug circuit, OpenSDA, provides an SWD interface and a power supply input through a single USB mini-AB connector, as well as a serial to USB, CDC class compliant UART interface.

6.1. Block diagram

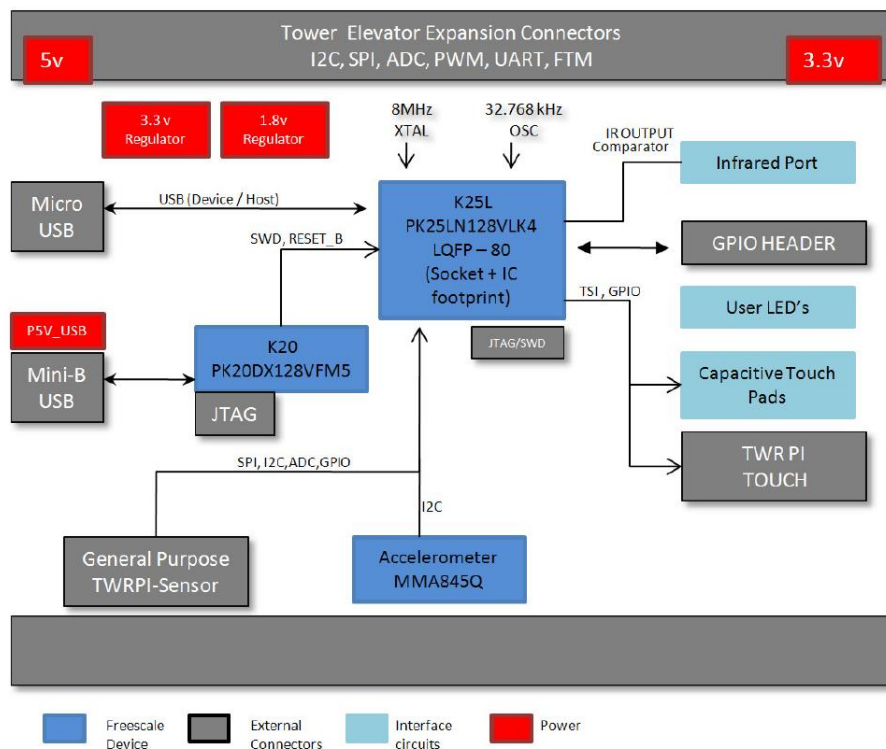

Figure 4. Block diagram of TWR-KL25Z

6.2. Microcontroller

The TWR-KL25Z features the MKL25Z128VLK4. This 48 MHz microcontroller is part of the Kinetis L series and is available in an 80 LQFP package. The following table notes the features of MKL25Z128VLK4.

Table 1. Features of MKL25Z128VLK4

Feature	Description
Ultra-low power	<ul style="list-style-type: none"> • 10 low-power modes with power and clock gating for optimal peripheral activity and recovery times. Stop currents of <150 nA (VLLS0), run currents of <130 uA/MHz, 4 μs wake-up from Stop mode. • Full memory and analog operation down to 1.71V for extended battery life. • Low-leakage wake-up unit with up to eight internal modules and sixteen pins as wake-up. Sources in low-leakage stop (LLS)/very low-leakage stop (VLLS) modes. • Low-power timer for continual system operation in reduced power states.
Flash and SRAM	<ul style="list-style-type: none"> • 32 KB – 128 KB flash featuring fast access times, high reliability, and four levels of security protection. • 4KB - 16 KB of SRAM. • No user or system intervention to complete programming and erase functions and full operation down to 1.71V.
Mixed-signal capability	<ul style="list-style-type: none"> • High-speed 16-bit ADC with configurable resolution. • Single or differential modes for improved noise rejection. • Analog comparator with 6-bit DAC reference. • 12-bit independent DAC.
Performance	<ul style="list-style-type: none"> • 48 MHz ARM Cortex-M0+ core. • Up to four channel DMA for peripheral and memory servicing with reduced CPU loading and faster system throughput. • Cross bar switch enables concurrent multi-master bus accesses, increasing bus bandwidth. • Bit manipulation engine (BME) allows execution of single-instruction atomic bit-modify-write operations on the peripheral address space.
Timing and Control	<ul style="list-style-type: none"> • Low power timers. • Two-channel 32-bit periodic interrupt timer provides time base for RTOS task scheduler or trigger source for ADC conversion.
Human-Machine Interface	<ul style="list-style-type: none"> • Hardware touch-sensing interface (TSI) with up to 16 inputs. • TSI operates in low power modes (minimum current adder when enabled). • TSI hardware implementation avoids software-polling methods. • High sensitivity level allows use of overlay surfaces up to 5 mm thick.
Connectivity and Communications	<ul style="list-style-type: none"> • Full-Speed USB Device/Host/On-The-Go with device charge detect capability. • Optimized charging current/time for portable USB devices, enabling longer battery life. • USB low-voltage regulator supplies up to 120 mA off chip at 3.3 volts to power external components from 5-volt input. • Three UARTs (one low power UART module that retains functionality in stop modes and two UART modules). • One Inter-IC Sound (I2S) serial interface for audio system interfacing. • Two SPI modules and two I2C modules.
Reliability, Safety and Security	<ul style="list-style-type: none"> • Independent-clocked computer operating properly (COP) guards against clock skew or code runaway for fail-safe applications such as the IEC 60730 safety standard for household appliances.

6.3. Clocking

The Kinetis MCUs start up from an internal digitally controlled oscillator (DCO). Software can enable the main external oscillator (EXTAL0/XTAL0) if desired. The external oscillator/resonator can range

from 32.768 KHz up to a 32 MHz. An 8 MHz crystal is the default external source for the MCG oscillator inputs (XTAL/EXTAL).

A 32.768 KHz oscillator connects to the RTC_CLKIN pin by default.

6.4. System Power

When installed into a Tower System, the TWR-KL25Z powers either from an on-board source or from another source in the assembled Tower System.

In stand-alone operation, the main power source (5.0V) for the TWR-KL25Z module derives from either the OpenSDA USB mini-B connector or the MKL25Z128VLK4 USB micro-AB connector (J31). Two low-dropout regulators provide 3.3V and 1.8V supplies from the 5.0V input voltage. Additionally, the 3.3V regulator built into the MKL25Z128VLK4 is selected to power the 3.3V bus. All the user selectable options can be configured using two headers, J3 and J8.

6.5. Real Time Clock (RTC)

Y500 is a 32.768 kHz clock connected to RTC_CLKIN. By enabling the external clock option in the RTC, it is used as a highly precise time reference.

6.6. Debug Interface

There are two debug interface options provided: the on-board OpenSDA circuit and an external ARM SWD connector.

6.6.1. OpenSDA

An on-board MK20-OpenSDA circuit provides an SWD debug interface to the KL25Z128. A standard USB A male to mini-B male cable (provided) is used for debugging via the USB connector, J22. The OpenSDA interface also provides a USB to serial bridge.

6.6.2. Cortex Debug SWD Connector

The Cortex Debug SWD connector is a standard 2x5-pin (0.05") connector providing an external debugger cable with access to the SWD interface of the KL25Z128.

Table 2. Cortex Debug connector

Pin	Function	TWR-KL25Z Connection
1	VTref	3.3V MCU supply (V_BRD)
2	SWDIO	PTA3/TSIO_CH4/I2C1_SCL/FTM0_CH0/SWD_DIO
3	GND	GND
4	SWCLK	PTA0/TSIO_CH1/FTM0_CH5/SWD_CLK
5	GND	GND
6	NC	NC
7	NC	NC

8	NC	NC
9	NC	NC
10	RESET	RESET_b

6.7. Infrared Port

An infrared transmit and receive interface is implemented as shown in [Figure 5](#). The UART2_TX pin directly drives an infrared diode. The receiver uses an infrared phototransistor connected to UART2_RX through a low-pass filter. Internal to the K20D50M device, the output of the analog comparator is routed to a UART module for easier processing of the incoming IrDA data stream.

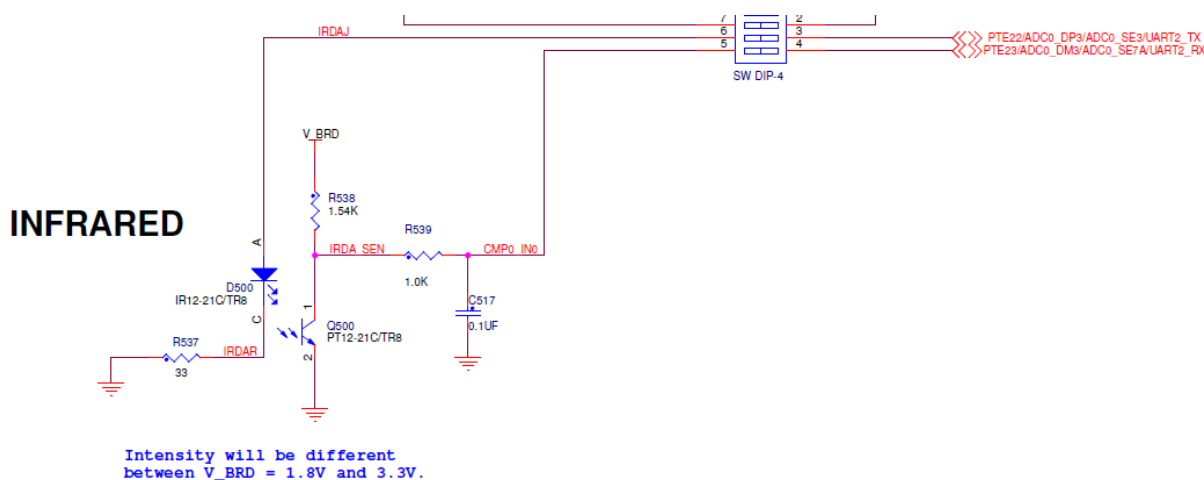

Figure 5. Infrared circuit

6.8. Accelerometer

An MMA8451Q digital accelerometer is connected to the KL25Z128 MCU through I2C module, I2C1, and GPIO/IRQ signals, PTC5 and PTC6. The MMA8451Q is a smart low-power, three-axis capacitive micro machined accelerometer with 14 bits of resolution. The device is configured to generate inertial wake-up interrupt signals from any combination of the configurable embedded functions allowing the MMA8451Q to monitor events and remain in a low-power mode during periods of inactivity. For more information on the MMA8451Q, please visit the [MMA8451Q Product Summary Page](#).

6.9. General Purpose Tower Plug-in (TWRPI) Socket

The TWR-KL25Z features a socket (J4 and J5) that can accept a variety of different Tower Plug-in modules featuring sensors, RF transceivers, and more. The General Purpose TWRPI socket provides access to I2C, SPI, IRQs, GPIOs, timers, analog conversion signals, TWRPI ID signals, reset, and voltage supplies. The pinout for the TWRPI Socket is defined [Table 3](#).

Table 3. General Purpose TWRPI socket pinout

J4		J5	
Pin	Description	Pin	Description
1	5V VCC	1	GND
2	3.3 V VCC	2	GND
3	GND	3	I2C: SCL
4	3.3V VDDA	4	I2C: SDA
5	VSS (Analog GND)	5	GND
6	VSS (Analog GND)	6	GND
7	VSS (Analog GND)	7	GND
8	ADC: Analog 0	8	GND
9	ADC: Analog 1	9	SPI: MISO
10	VSS (Analog GND)	10	SPI: MOSI
11	VSS (Analog GND)	11	SPI: SS
12	ADC: Analog 2	12	SPI: CLK
13	VSS (Analog GND)	13	GND
14	VSS (Analog GND)	14	GND
15	GND	15	GPIO: GPIO0/IRQ
16	GND	16	GPIO: GPIO1/IRQ
17	ADC: TWRPI ID 0	17	UART0_RX / GPIO: GPIO2
18	ADC: TWRPI ID 1	18	GPIO: GPIO3
19	GND	19	GPIO: GPIO4/Timer
20	Reset	20	UART0_TX / GPIO: GPIO5

6.10. Potentiometer, Pushbuttons, LEDs

The TWR-KL25Z features two pushbutton switches connected to GPIO/interrupt signals, one pushbutton connected to the master reset signal, two capacitive touch pad electrodes, four user-controllable LEDs, and a potentiometer connected to an ADC input signal. Refer to [Table 6 “Connectors and Pin Usage”](#) for information about which pins are connected to these features.

6.11. Touch Interface

The touch sensing input (TSI) module of the KL25Z128 MCU provides capacitive touch sensing detection with high sensitivity and enhanced robustness. Each TSI pin implements the capacitive measurement of an electrode.

The TWR-KL25Z provides two methods for evaluating the TSI module. There are two electrodes on-board. Additionally, 12 TSI signals are connected to a Touch Tower Plug-in (TWRPI) socket (J2) that can accept Touch TWRPI daughter cards that may feature keypads, rotary dials, sliders, etc.

Table 4. Touch TWRPI socket pinout

Pin	Description
1	P5V_TRG_USB
2	V_BRD
3	TSI0_CH9
4	3.3V VDDA
5	TSI0_CH10
6	VSS (Analog GND)
7	TSI0_CH11
8	TSI0_CH12
9	TSI0_CH13
10	TSI0_CH0
11	TSI0_CH6
12	TSI0_CH7
13	TSI0_CH8
14	TSI0_CH1
15	TSI0_CH4
16	TSI0_CH3
17	ADC: TWRPI ID 0
18	ADC: TWRPI ID 1
19	GND
20	Reset

6.12. USB

The KL25Z128 features a full-speed/low-speed USB module with OTG/Host/Device capability and built-in transceiver. The TWR-KL25Z routes the USB D+ and D- signals from the KL25Z128 MCU directly to the on-board USB connector (J13)

A power supply switch with an enable input signal and over-current flag output signal is used to supply power to the USB connector when the KL25Z128 is operating in host mode.

7. TWR-KL25Z Jumper Options

The following is a list of all the jumper options. The default installed jumper settings are shown in bold.

NOTE

Default Configuration: vBoard is powered by OpenSDA USB and RTC is powered by V_BRD.

Table 5. Jumper options

Jumper	Jumper designator	Signal	Jumper Option
V_BRD	J7	V_BRD	DEF: 1-2 VBRD to MCU_PWR
	J9	VDDA_HDR	DEF: 1-2 VDDA to MCU_PWR
VREG IN SELECTOR	J8	VREG IN SELECTOR	DEF: 1-2 Regulator powered by OpenSDA USB 2-3 Regulator powered by tower elevator power
BOARD POWER SELECTION	J3	BOARD POWER SELECTION	DEF: 1-3 P3.3V_REG powers V_BRD(MCU_PWR) 3-5 1.8V powers VBRD (MCU & Interface circuit input power)

Table 6. Connectors and Pin Usage

Module	Board Designator	Name	Options	Signal
USB	J6	KL25 VOUT33	DEF: OPEN	MCU_PWR
	J18	KL25 USB VREGIN	DEF: OPEN	P5V_VREGIN_K25
	J20	KL25 USB ENA	DEF: OPEN	PTB11/SPI1_SCK
	J21	KL25 USB FLGA	DEF: OPEN	PTE31/FTM0_CH4
IRDA	SW1 6-3	IRDAJ	OPEN	PTE22/ADC0_DP3/ADC0_SE3/U ART2_TX
	SW1 5-4	CMP0_IN0	OPEN	PTE23/ADC0_DM3/ADC0_SE7A/ UART2_RX
Potentiometer	J1	POT 5K	DEF: 1-2	PTE29/ADC0_SE4B
Accelerometer	J24	SDA Accelerometer Enable	DEF: 1-2	PTC11/I2C1_SDA
	J23	SCL Accelerometer Enable	DEF: 1-2	PTC10/I2C1_SCL
	J14	ACCELEROMETER INT1	DEF: OPEN	PTC5/LLWU_P9/SPI0_SCK/CMP 0_OUT
	J15	ACCELEROMETER INT2	DEF: OPEN	PTC6/LLWU_P10/EXTRG_IN/SPI 0_MISO
GPIO Header	J11-1	PTE20/ADC0_DP0/ADC0_S E0		
	J11-2	PTE21/ADC0_DM0/ADC0_ SE4A		
	J11-3	PTA1/TSIO_CH2/UART0_R X		
	J11-4	GND		
	J11-5	SWD_DIO_TGTMCU		
	J11-6	PTE31/FTM0_CH4		
	J11-7	PTB9		
	J11-8	PTA2/TSIO_CH3/UART0_T X		
	J11-9	PTB11/SPI1_SCK		
	J11-11	PTB10/SPI1_PCS0		
	J11-12	GND		
	J11-13	PTC4/LLWU_P8/UART1_TX /FTM0_CH3		
	J11-14	PTC3/LLWU_P7/UART1_R X/FTM0_CH2/CLKOUT		
	J11-15	PTC12/FTM_CLKIN0		
	J11-16	PTC6/LLWU_P10/EXTRG_I N/SPI0_MISO		
	J11-17	PTC16		
	J11-18	PTC13/FTM_CLKIN1		
	J11-19	GND		

Module	Board Designator	Name	Options	Signal
	J11-20	PTC17		
LEDs	J19	LED orange Enable	DEF: 1-2	PTA5/FTM0_CH2
	J22	LED Yellow Enable	DEF: 1-2	PTA16
	SW1 8-1	LED Green Enable	OPEN	PTA17
	SW1 7-2	LED Red Enable	OPEN	PTB8/EXTRG_IN
Push Buttons	SW3	SW3	PTA4	PTA4
	SW4	SW4	PTC3	PTC3/LLWU_P7/UART1_RX/FTM0_CH2/CLKOUT
TSI Electrodes	Elec1	Electrode1	TSI0_CH9	PTB16/TSI0_CH9/UART0_RX
	Elec2	Electrode2	TSI0_CH10	PTB17/TSI0_CH10
UART	J24	KL25 UART RX (OpenSDA or Elevator)	DEF: 2-3	UART1_RX_TGTMCU
	J26	KL25 UART TX (OpenSDA or Elevator)	DEF: 2-3	UART1_TX_TGTMCU

8. Useful Links

- <http://www.nxp.com/TWR-KL25Z48M>
- www.nxp.com
- www.iar.com/nxp
- www.pemicro.com
- www.nxp.com/codewarrior
 - CodeWarrior MCUv10.3 and above
- www.segger.com
 - <http://www.segger.com/jlink-flash-download.htm>

9. Revision History

Table 7. Sample revision history

Revision number	Date	Substantive changes
1.0	July, 2012	Initial release
1.0.1	September, 2012	First version. Updated to board rev C.
1.1	September 2016	Updated the contents section, web links and general information corrections.



How to Reach Us:

Home Page:

nxp.com

Web Support:

nxp.com/support

Information in this document is provided solely to enable system and software implementers to use NXP products. There are no express or implied copyright licenses granted hereunder to design or fabricate any integrated circuits based on the information in this document. NXP reserves the right to make changes without further notice to any products herein.

NXP makes no warranty, representation, or guarantee regarding the suitability of its products for any particular purpose, nor does NXP assume any liability arising out of the application or use of any product or circuit, and specifically disclaims any and all liability, including without limitation consequential or incidental damages. "Typical" parameters that may be provided in NXP data sheets and/or specifications can and do vary in different applications, and actual performance may vary over time. All operating parameters, including "typicals," must be validated for each customer application by customer's technical experts. NXP does not convey any license under its patent rights nor the rights of others. NXP sells products pursuant to standard terms and conditions of sale, which can be found at the following address:

nxp.com/SalesTermsandConditions.

NXP, the NXP logo, NXP SECURE CONNECTIONS FOR A SMARTER WORLD, Freescale, the Freescale logo, CodeWarrior, Energy Efficient Solutions logo, Kinetis, and Tower are trademarks of NXP B.V. All other product or service names are the property of their respective owners.

ARM, the ARM logo, and Cortex are registered trademarks of ARM Limited (or its subsidiaries) in the EU and/or elsewhere.

© 2016 NXP B.V.

Document Number: TWR-KL25Z-UM

Rev. 1.1

09/2016





**Стандарт
Электрон
Связь**

Мы молодая и активно развивающаяся компания в области поставок электронных компонентов. Мы поставляем электронные компоненты отечественного и импортного производства напрямую от производителей и с крупнейших складов мира.

Благодаря сотрудничеству с мировыми поставщиками мы осуществляем комплексные и плановые поставки широчайшего спектра электронных компонентов.

Собственная эффективная логистика и склад в обеспечивает надежную поставку продукции в точно указанные сроки по всей России.

Мы осуществляем техническую поддержку нашим клиентам и предпродажную проверку качества продукции. На все поставляемые продукты мы предоставляем гарантию .

Осуществляем поставки продукции под контролем ВП МО РФ на предприятия военно-промышленного комплекса России , а также работаем в рамках 275 ФЗ с открытием отдельных счетов в уполномоченном банке. Система менеджмента качества компании соответствует требованиям ГОСТ ISO 9001.

Минимальные сроки поставки, гибкие цены, неограниченный ассортимент и индивидуальный подход к клиентам являются основой для выстраивания долгосрочного и эффективного сотрудничества с предприятиями радиоэлектронной промышленности, предприятиями ВПК и научно-исследовательскими институтами России.

С нами вы становитесь еще успешнее!

Наши контакты:

Телефон: +7 812 627 14 35

Электронная почта: sales@st-electron.ru

Адрес: 198099, Санкт-Петербург,
Промышленная ул, дом № 19, литера Н,
помещение 100-Н Офис 331