

PRODUCT NUMBER  
SEE SHEET 3

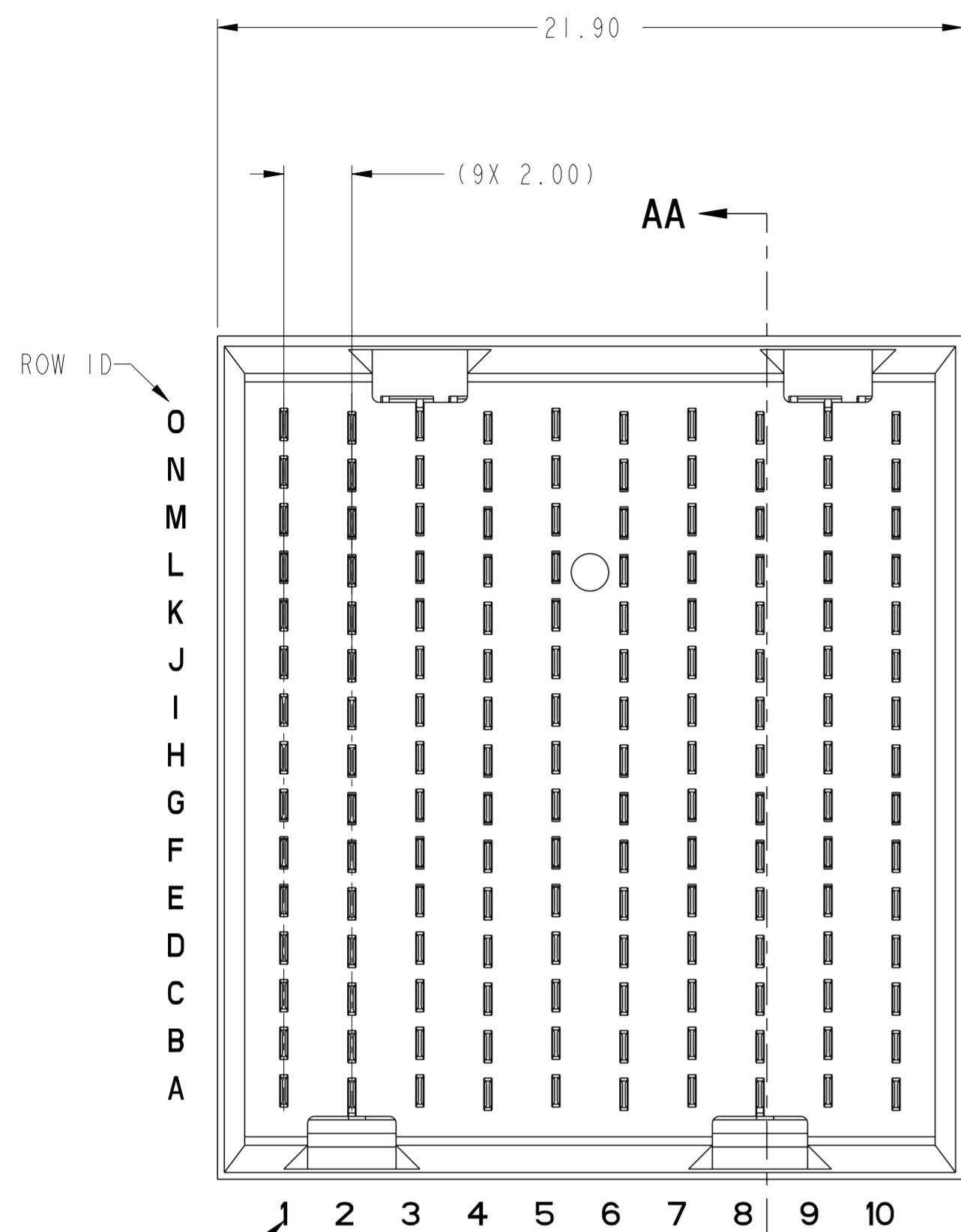

COLUMN ID

ROW ID

2.35  $\phi$  OF EVEN COLUMNS  
2.25  $\phi$  OF ODD COLUMNS

(24.80)

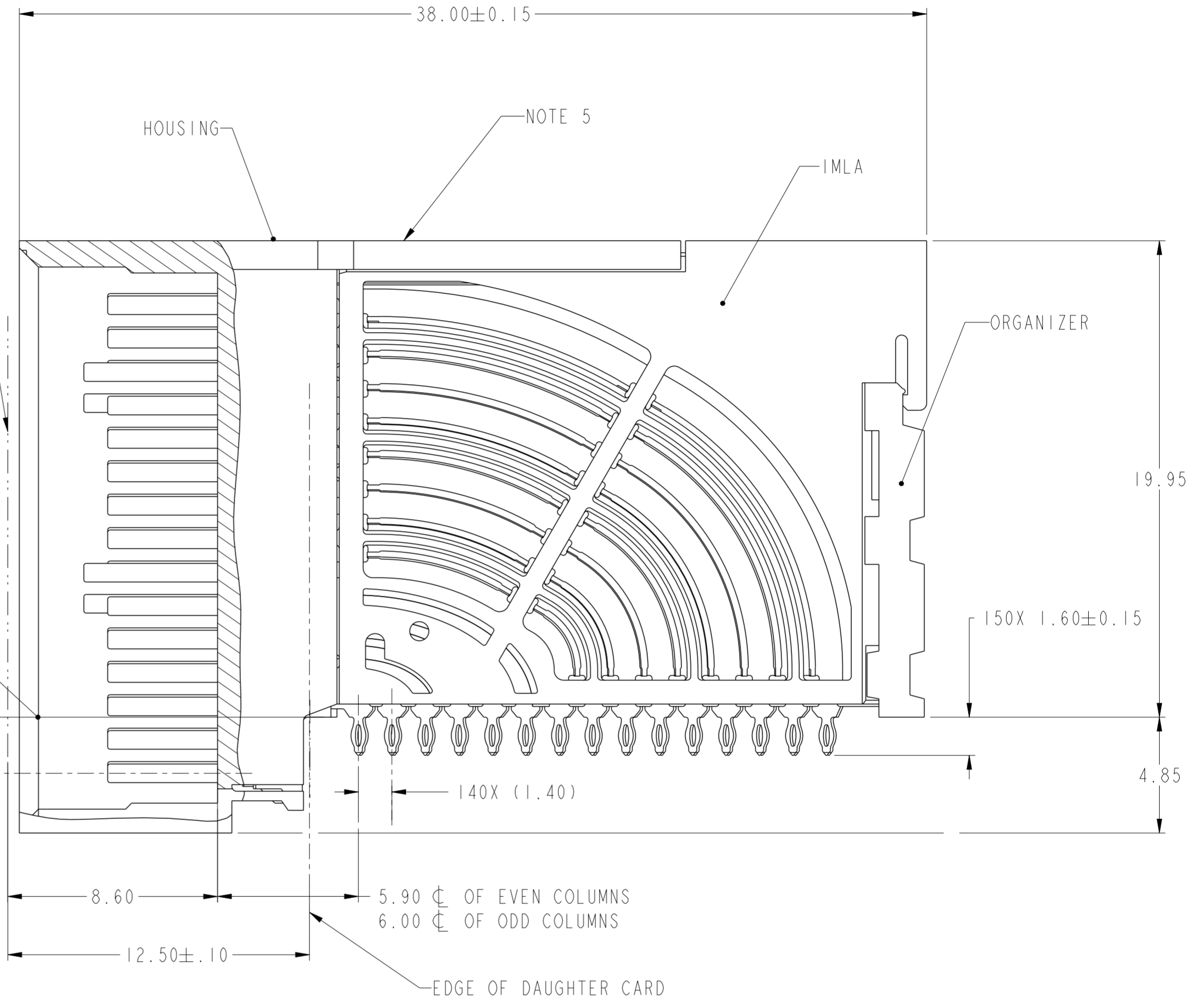

TOP SURFACE OF MOTHER BOARD

TOP SURFACE OF DAUGHTER CARD

EDGE OF DAUGHTER CARD

SECTION AA-AA

spec ref	---	dr	Lin-Sze Ngwe	2012/12/05	projection	MM	size	A2	scale	10:1									
tolerance std	ASME Y14.5M	eng	Art Lin	2016/11/10			ecn no	ELX-DG-2525-1	rel level	Released									
TOLERANCES UNLESS OTHERWISE SPECIFIED		chr	Heaven Cen	2016/11/17															
		appr	Pai-Ming Zheng	2016/11/18															
surface	<table border="1"> <tr> <td>linear</td> <td>0.X</td> <td>±.3</td> </tr> <tr> <td></td> <td>0.XX</td> <td>±.15</td> </tr> <tr> <td></td> <td>0.XXX</td> <td>±.050</td> </tr> <tr> <td>angular</td> <td>0°</td> <td>±2°</td> </tr> </table>	linear	0.X	±.3		0.XX	±.15		0.XXX	±.050	angular	0°	±2°			<b>Product Family</b> AirMax VS2 R.A. HEADER 5 Pair, 150 pos, 2mm, 10 Col		title 10123529	rev D
linear	0.X	±.3																	
	0.XX	±.15																	
	0.XXX	±.050																	
angular	0°	±2°																	
		www.fci.com		cat. no.	Product - Customer Drw		sheet 1 of 3												

PDS: Rev :D

STATUS:Released

Printed: Nov 18, 2016

Amphenol  
FCI

© 2016 APCI

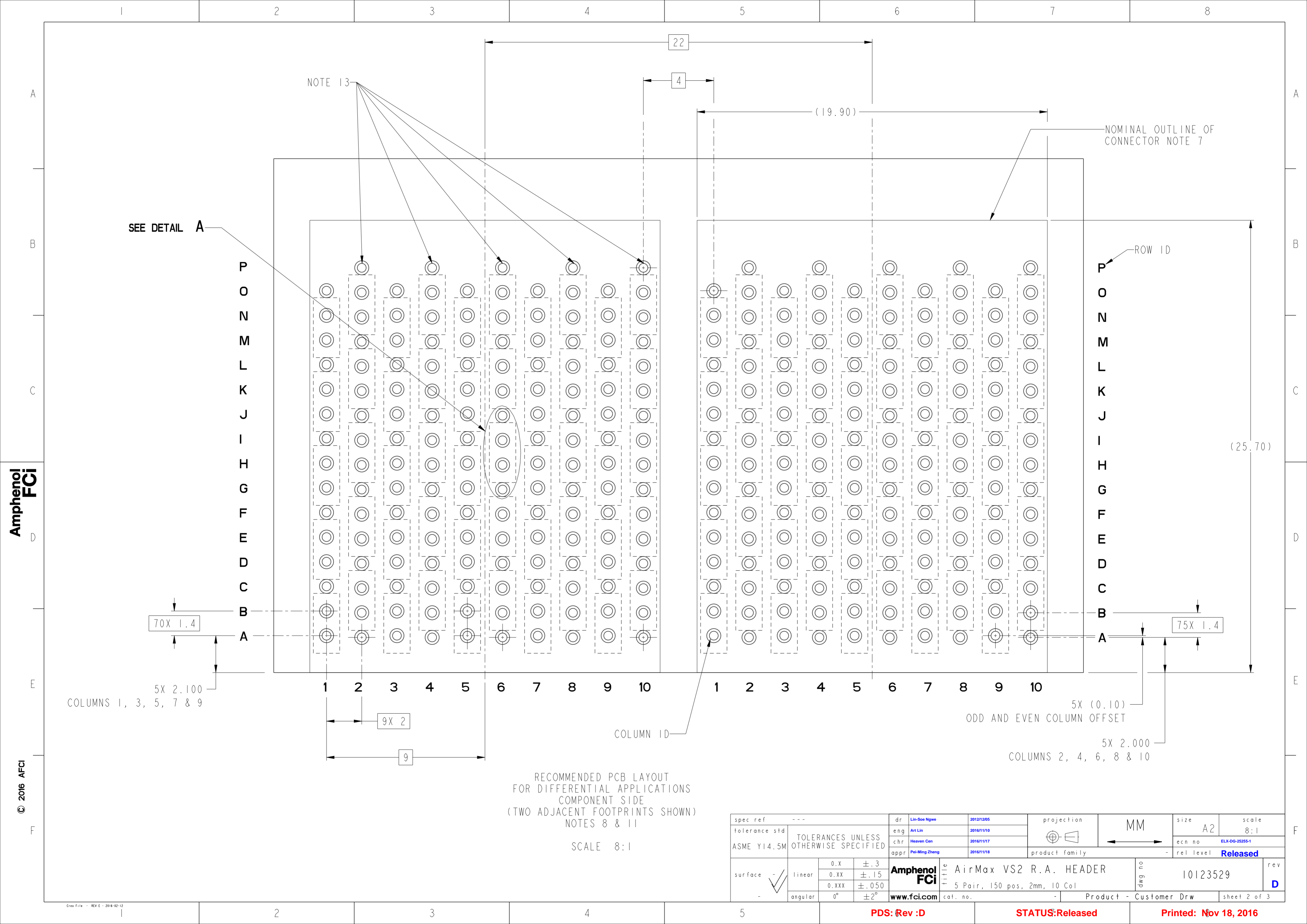

NOTE 13

SEE DETAIL A

NOMINAL OUTLINE OF CONNECTOR NOTE 7

ROW ID

COLUMN ID

RECOMMENDED PCB LAYOUT  
FOR DIFFERENTIAL APPLICATIONS  
COMPONENT SIDE  
(TWO ADJACENT FOOTPRINTS SHOWN)  
NOTES 8 & 11

SCALE 8:1

spec ref	---	dr	Lin-Soe Ngwe	2012/2005	projection	MM	size	A2	scale	8:1								
tolerance std	ASME Y14.5M	eng	Art Lin	2016/11/10			ecn no	ELX-DG-2525-1										
TOLERANCES UNLESS OTHERWISE SPECIFIED		chr	Heaven Cen	2016/11/17			rel level	Released										
		appr	Pai-Ming Zheng	2016/11/18			product family	-										
surface	<table border="1"> <tr> <td>linear</td> <td>0.X</td> <td>±.3</td> </tr> <tr> <td></td> <td>0.XX</td> <td>±.15</td> </tr> <tr> <td></td> <td>0.XXX</td> <td>±.050</td> </tr> <tr> <td>angular</td> <td>0°</td> <td>±2°</td> </tr> </table>	linear	0.X	±.3		0.XX	±.15		0.XXX	±.050	angular	0°	±2°		<b>Amphenol FCI</b> title AirMax VS2 R.A. HEADER 5 Pair, 150 pos, 2mm, 10 Col www.fci.com	cat. no. - Product - Customer Drw	drg no 10123529	rev D
linear	0.X	±.3																
	0.XX	±.15																
	0.XXX	±.050																
angular	0°	±2°																

Amphenol FCI

© 2016 APCI

5X 2.100  
COLUMNS 1, 3, 5, 7 & 9

5X (0.10)  
ODD AND EVEN COLUMN OFFSET

5X 2.000  
COLUMNS 2, 4, 6, 8 & 10

9X 2

9

70X 1.4

75X 1.4

(25.70)

22

4

(19.90)

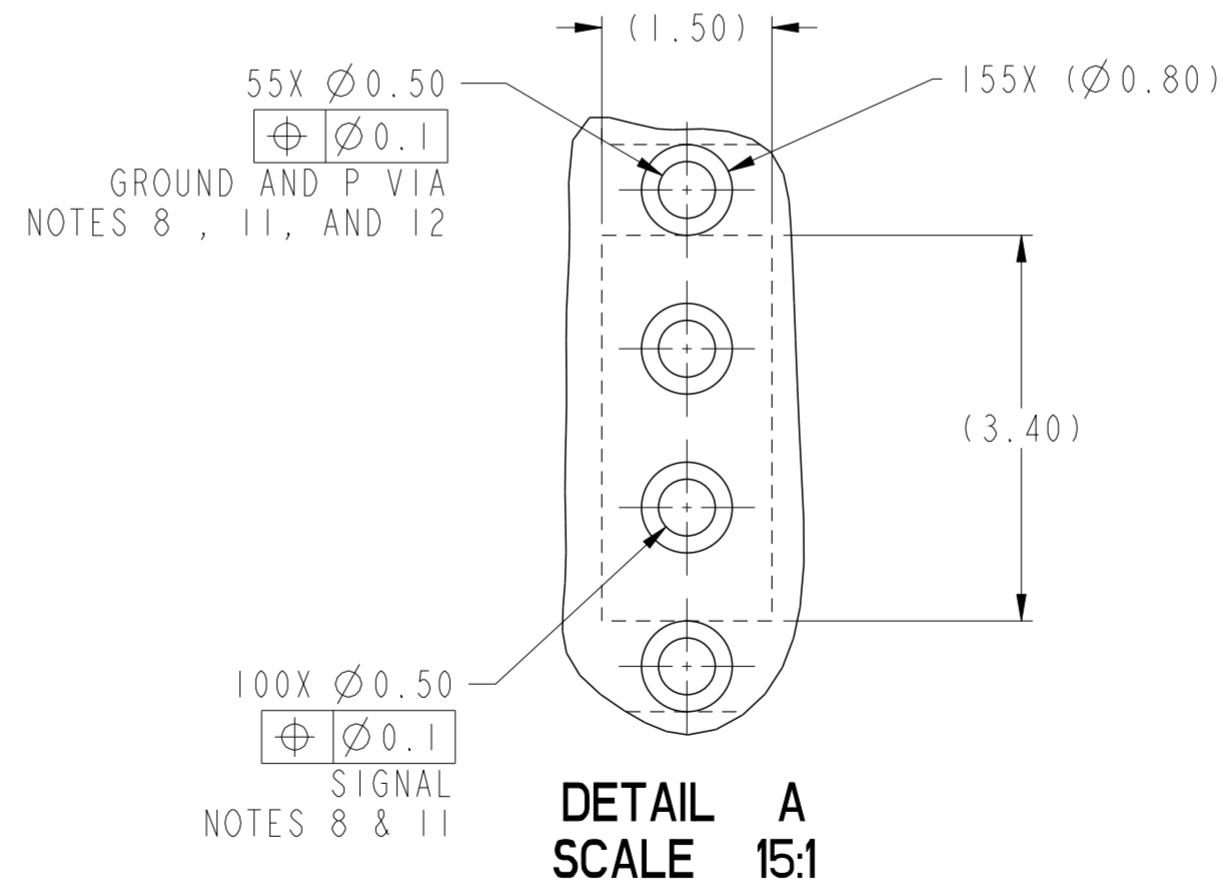
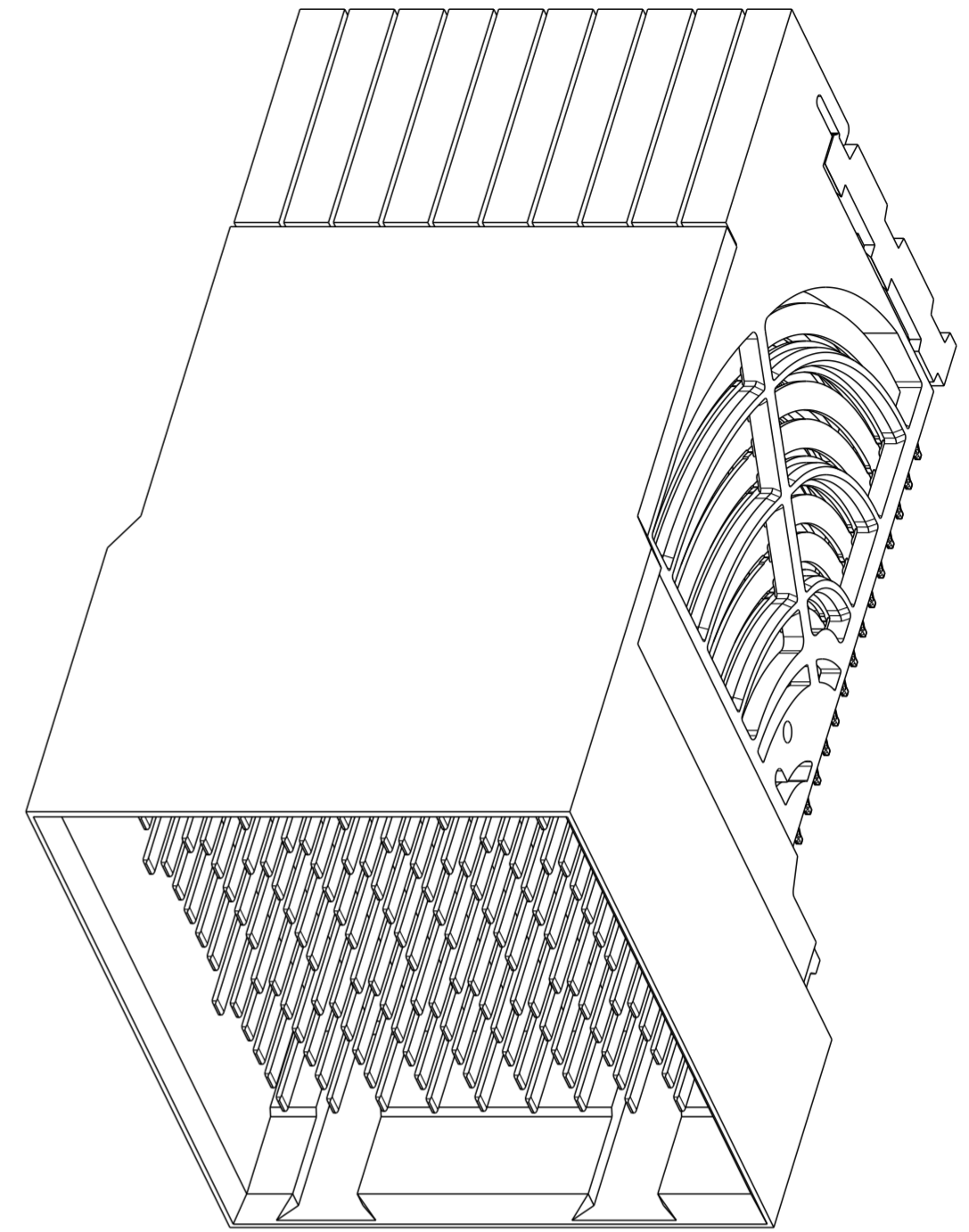

PRODUCT NUMBER	PRESS-FIT TAIL PLATING TYPE	REMARK
10123529-101	TIN/LEAD ALLOY OVER NICKEL	1-SIDE PLATING (CUSTOMER SPECIAL)
10123529-101LF	TIN OVER NICKEL (LEAD FREE)	
10123529-102	TIN/LEAD ALLOY OVER NICKEL	2-SIDE PLATING
10123529-102LF	TIN OVER NICKEL (LEAD FREE)	

- 1 - CONNECTOR MATERIALS:  
HOUSING: HIGH TEMP THERMOPLASTIC, NATURAL, UL94-V0  
IMLA PLASTIC: HIGH TEMP THERMOPLASTIC, BLACK, UL94-V0  
CONTACT: COPPER ALLOY  
ORGANIZER: HIGH TEMP THERMOPLASTIC, NATURAL, UL94-V0
- 2 - CONTACT PLATING:  
SEPARABLE INTERFACE:  
PERFORMANCE-BASED PLATING, QUALIFIED TO MEET THE REQUIREMENTS OF FCI PRODUCT SPECIFICATION GS-12-0956 INCLUDING TELCORDIA GR-1217-CORE (NOVEMBER 1995) CENTRAL OFFICE TEST SEQUENCE
- PRESS-FIT TAILS: SEE TABLE
- 3 - PRODUCT SPECIFICATION: GS-12-0956
- 4 - APPLICATION SPECIFICATION: GS-20-0305
- 5 - PRODUCT MARKING, (PROTOTYPE, PART NUMBER & LOT CODE), ON THIS SURFACE.
- 6 - POSITIONS "F" AND "L" OF ODD NUMBERED COLUMNS AND POSITIONS "G" AND "M" OF EVEN NUMBERED COLUMNS CORRESPOND TO EARLY MATE HEADER PINS.
- 7 - CONNECTOR OUTLINE MAY BE SCREEN PRINTED ONTO CUSTOMER PCB TO BE USED AS A GUIDE FOR CONNECTOR PLACEMENT.
- 8 - REFER TO CUSTOMER DRAWING 10104444 FOR INFORMATION ON PCB HOLE DIAMETERS AND PLATING OPTIONS
- 9 - LEAD FREE PRODUCT MEETS THE EUROPEAN UNION DIRECTIVES & OTHER COUNTRY REGULATIONS AS DESCRIBED IN GS-22-008
- 10 - PACKAGING MEETS GS-14-920 LEAD FREE LABELING SPECIFICATION.
- 11 - GROUND CONTACTS (C, F, I, L, & O IN ODD COLUMNS AND A, D, G, J, & M IN EVEN COLUMNS) REQUIRE (Ø0.50) FINISHED HOLES. SIGNAL LOCATIONS REQUIRE (Ø0.50) FINISHED HOLES
- 12 - THESE OUTER VIAS (P) ARE OPTIONAL. WHILE NO CONNECTOR EONS ARE PRESSED INTO THESE HOLES WE RECCOMMEND (Ø0.500) FINISHED HOLES AT THESE LOCATIONS TO PROVIDE GROUND SYMMETRY THROUGH THE PCB.
- 13 - A  SYMBOL WILL BE NEXT TO ANY DIMENSION, VIEW, OR NOTE, WHICH HAS BEEN MODIFIED WITH THE CURRENT DRAWING REVISION.

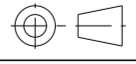

10123529-101 OR -101LF  
10123529-102 OR -102LF

SCALE 4:1

spec ref	---	dr	Lin-Soe Ngwe	2012/2/05	projection	MM	size	A2	scale	10:1											
tolerance std	ASME Y14.5M	eng	Art Lin	2016/11/10			ecn no	ELX-DG-25255-1	rel level	Released											
TOLERANCES UNLESS OTHERWISE SPECIFIED		chr	Heaven Cen	2016/11/17																	
		appr	Pai-Ming Zheng	2016/11/18																	
surface	<table border="1"> <tr> <td>linear</td> <td>0.X</td> <td>±.3</td> </tr> <tr> <td></td> <td>0.XX</td> <td>±.15</td> </tr> <tr> <td></td> <td>0.XXX</td> <td>±.050</td> </tr> <tr> <td>angular</td> <td>0°</td> <td>±2°</td> </tr> </table>	linear	0.X	±.3		0.XX	±.15		0.XXX	±.050	angular	0°	±2°	<b>Amphenol FCI</b> www.fci.com		<b>title</b> AirMax VS2 R.A. HEADER 5 Pair, 150 pos, 2mm, 10 Col		<b>dwg no</b> 10123529	<b>rev</b> D	Product - Customer Drw sheet 3 of 3	
linear	0.X	±.3																			
	0.XX	±.15																			
	0.XXX	±.050																			
angular	0°	±2°																			



**Стандарт  
Электрон  
Связь**

Мы молодая и активно развивающаяся компания в области поставок электронных компонентов. Мы поставляем электронные компоненты отечественного и импортного производства напрямую от производителей и с крупнейших складов мира.

Благодаря сотрудничеству с мировыми поставщиками мы осуществляем комплексные и плановые поставки широчайшего спектра электронных компонентов.

Собственная эффективная логистика и склад в обеспечивает надежную поставку продукции в точно указанные сроки по всей России.

Мы осуществляем техническую поддержку нашим клиентам и предпродажную проверку качества продукции. На все поставляемые продукты мы предоставляем гарантию .

Осуществляем поставки продукции под контролем ВП МО РФ на предприятия военно-промышленного комплекса России , а также работаем в рамках 275 ФЗ с открытием отдельных счетов в уполномоченном банке. Система менеджмента качества компании соответствует требованиям ГОСТ ISO 9001.

Минимальные сроки поставки, гибкие цены, неограниченный ассортимент и индивидуальный подход к клиентам являются основой для выстраивания долгосрочного и эффективного сотрудничества с предприятиями радиоэлектронной промышленности, предприятиями ВПК и научно-исследовательскими институтами России.

С нами вы становитесь еще успешнее!

**Наши контакты:**

**Телефон:** +7 812 627 14 35

**Электронная почта:** [sales@st-electron.ru](mailto:sales@st-electron.ru)

**Адрес:** 198099, Санкт-Петербург,  
Промышленная ул, дом № 19, литера Н,  
помещение 100-Н Офис 331