

## ED Series



- AC output Solid State Relay in an Industry standard EMR plug in package
- Ratings of 1, 3 & 5 Amps
- Load voltage range of 24-280VAC
- Fits standard DIN rail & PCB mountable sockets
- LED input status indicator
- AC or DC control
- cUL Recognized, IEC Rated, CE & RoHS Compliant
- Horsepower Rated, Pilot Duty Rated

### PRODUCT SELECTION

Control Voltage	1 A	3 A	5 A
3-15 VDC Control	ED24D1	ED24D3	ED24D5
18.5-32 VDC Control	ED24C1	ED24C3	ED24C5
48-72 VDC Control		ED24F3	ED24F5
18-36 VAC Control			ED24E5
90-140 VAC Control			ED24B5

### AVAILABLE OPTIONS



### OUTPUT SPECIFICATIONS AC Output <sup>(1)</sup>

Description	1 A	3 A	5 A
Operating Voltage (47-63Hz) [Vrms]	24-280	24-280	24-280
Transient Overvoltage [Vpk]	600	600	600
Maximum Resistive Load Current UL 508/ IEC 62314 LC-A [Arms, FLA] <sup>(2)</sup>	1.5	3	5
Minimum Load Current [Arms]	0.025	0.15	0.15
Maximum Off-State Leakage Current @ Rated Voltage [mArms]	0.1	0.1	0.1
Minimum Off-State dv/dt @ Maximum Rated Voltage [V/μsec] <sup>(3)</sup>	500	500	500
Maximum On-State Voltage Drop @ Rated Current [Vpk]	1.1	1.1	1.1
Maximum Surge Current (50/60 Hz, 1 cycle) [Apk]	38/40	240/250	600/625
Maximum I <sup>2</sup> t for Fusing (50/60 HZ, 1/2 cycle) [A <sup>2</sup> sec]	7/6	285/260	1780/1620
UL 508 HP/IEC 62314 LC-B Rating @ 240V, 40°C [HP/KW]	NA	0.25 / 0.37	0.5 / 0.55
Minimum Power Factor (with Maximum Load)	0.5	0.5	0.5

**INPUT SPECIFICATIONS (1)**

Description	ED24Dx	ED24Cx	ED24Fx	ED24Ex	ED24Bx
Control Voltage Range	3-15 VDC	18.5-32 VDC	48-72 VDC	18-36 VAC	90-140 VAC
Minimum Turn-On Voltage	3 VDC	18.5 VDC	48 VDC	18 VAC	90 VAC
Minimum Turn-Off Voltage	1.9 VDC	10.0 VDC	24 VDC	8 VAC	20 VAC
Maximum Reverse Voltage	6 VDC	6 VDC	6 VDC	N/A	N/A
Minimum Input Current [mA]	3.8	3.8	3.8	3.8	3.2
Maximum Input Current [mA]	33.8	6.9	5.8	8.5	4.9
Nominal Input Impedance [ohms]	500	4.8K	12.5K	4.5K	28K
Maximum Turn-On Time [msec] (4)	8.33	8.33	8.33	20	20
Maximum Turn-Off Time [msec]	8.33	8.33	8.33	30	30

**GENERAL SPECIFICATIONS (1)**

Description	Parameters
Dielectric Strength, Input/Output (50/60Hz)	3750 Vrms
Minimum Insulation Resistance (@ 500 V DC)	10 <sup>9</sup> Ohms
Maximum Capacitance, Input/Output	10 pF
Ambient Operating Temperature Range	-30°C to 80°C
Ambient Storage Temperature Range	-40°C to 125°C
Weight (typical)	1.06 oz. (30 g)
Maximum Humidity	85% non-condensing
Housing Material	Polyamide Class V0 (UL94)
Terminals Material	Copper w/Sulfamet Nickel finish

**GENERAL NOTES**

- 1) All parameters at 25°C unless otherwise specified.
- 2) Based on 17mm (5A model) and 13mm (3A model) spacing minimum between parts.
- 3) Off-State dv/dt test method per EIA/NARM standard RS-443, paragraph 13.11.1
- 4) Turn-On time for Random turn-on versions is 0.1ms for DC control and 5ms for AC control.

**MECHANICAL SPECIFICATIONS**

Tolerances: ±0.02 in / 0.5 mm  
All dimensions are in: inches [millimeters]

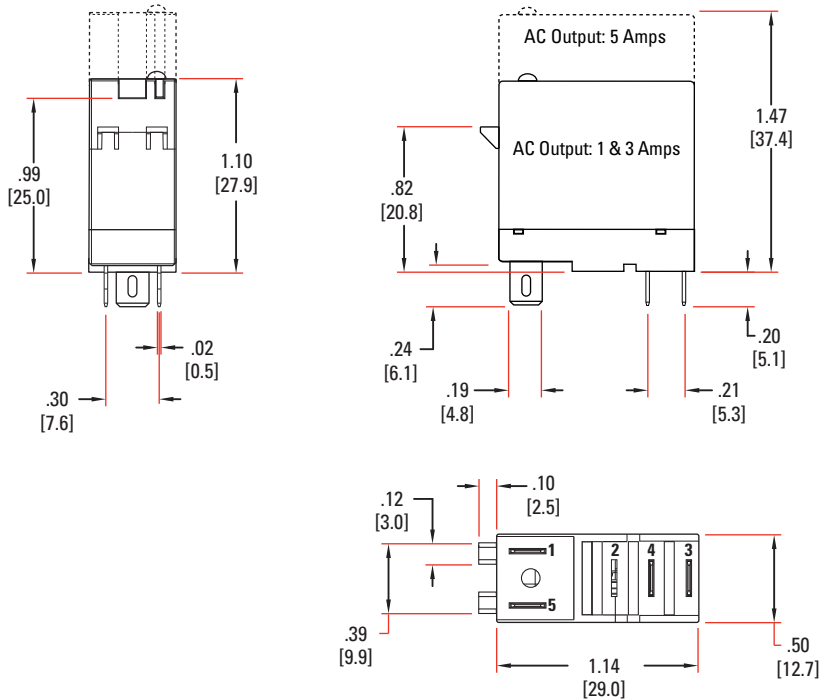

**WIRING DIAGRAM**



LOAD CAN BE WIRED IN POSITION A or B

**THERMAL DERATE INFORMATION**

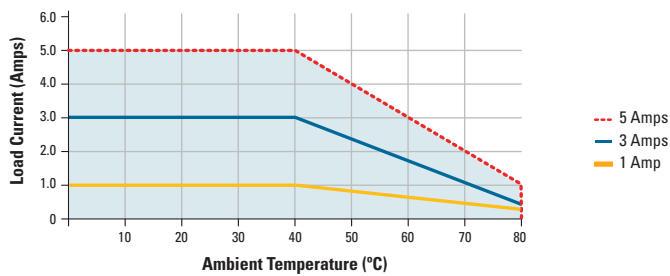

Above curve is based on a minimum spacing between parts of 17mm for ED24X5 and 13mm for ED24x3. Maximum current @ 0mm spacing is 2.7A for ED24x5 and 2.3A for ED24x3 @ 40°C.

Derating Value: ED24x5 = 0.135A per mm  
ED24x3 = 0.054A per mm

Derating based on Relay air gap:

Example: 10mm spacing with a ED24D5 SSR

- 1.- Subtract spacing from the minimum required spacing of the part (17mm) to get the correction value.  
 $17-10=7$
- 2.- Multiply air gap derating value found above with correction value  
 $0.135 \times 7 = 0.945A$

Now using this final number we can figure out what the maximum current the relay can carry with 10mm spacing @ 60°C Ambient.

- 3.- using the Ambient Derating Curve above find the current for the 5A model @ 60°C. In this case that value is 3A.
- 4.- Subtract the value above (0.945A) from 3A.  
 $3-0.945 = 2.055A$

The maximum current you can switch with the ED24D5 with a 10mm air gap between relays @ 60°C ambient is 2.055A

## AGENCY APPROVALS

Designed in accordance with the requirements of IEC 62314  
Pilot Duty Rated C300

IEC 61000-4-2 : Electrostatic Discharge Level 3 – Criteria A

IEC 61000-4-4 : Electrically Fast Transients Level 3 – Criteria B

IEC 61000-4-5 : Electrical Surges Level 3 – Criteria A



## ACCESSORIES

### ED Series Accessories

DRSED



#### **DIN Rail Mountable Socket**

Part no.: DRSED

Fingersafe IP10 DIN rail mountable socket to mount ED series relays onto standard 35 mm DIN rail. Rated at 250 V AC/DC, 12 Amps. The DRSED includes M3 Combo screws.

PCBSED



#### **PC Board Mountable Socket**

Part no.: PCBSED

PC Board mountable socket for ED series relays. Rated at 250 V AC/DC, 12 Amps. Suggested Pin-out hole diameter: 1.0 mm

**⚠ DANGER / PELIGRO / DANGER /GEFAHR / PERICOLO / 危险**

<p><b>HAZARD OF ELECTRIC SHOCK, EXPLOSION, OR ARC FLASH.</b></p> <ul style="list-style-type: none"> <li>• Disconnect all power before installing or working with this equipment.</li> <li>• Verify all connections and replace all covers before turning on power.</li> </ul> <p><b>Failure to follow these instructions will result in death or serious injury.</b></p>	<p><b>RIESGO DE DESCARGA ELECTRICA O EXPLOSION.</b></p> <ul style="list-style-type: none"> <li>• Desconectar todos los suministros de energia a este equipo antes de trabajar con este equipo.</li> <li>• Verificar todas las conexiones y colocar todas las tapas antes de energizar el equipo.</li> </ul> <p><b>El incumplimiento de estas instrucciones puede provocar la muerte o lesiones serias.</b></p>	<p><b>RISQUE DE DESCARGE ELECTRIQUE OU EXPLOSION</b></p> <ul style="list-style-type: none"> <li>• Eteindre toutes les sources d'énergie de cet appareil avant de travailler dessus de cet appareil</li> <li>• Vérifier tous connections, et remettre tous couverts en place avant de mettre sous</li> </ul> <p><b>De non-suivi de ces instructions provoquera la mort ou des lésions sérieuses.</b></p>	<p><b>GEFAHR EINES ELEKTRISCHE N SCHLAGES ODER EINER EXPLOSION.</b></p> <ul style="list-style-type: none"> <li>• Stellen Sie jeglichen Strom ab, der dieses Gerät versorgt, bevor Sie an dem Gerät Arbeiten durchführen</li> <li>• Vor dem Drehen auf Energie alle Anschlüsse überprüfen und alle Abdeckungen ersetzen.</li> </ul> <p><b>Unterlassung dieser Anweisungen können zum Tode oder zu schweren Verletzungen führen.</b></p>	<p><b>RISCHIO DI SCOSSA ELETTRICA O DELL'ESPLOSIONE.</b></p> <ul style="list-style-type: none"> <li>• Spenga tutta l'alimentazione che fornisce questa apparecchiatura prima di lavorare a questa apparecchiatura</li> <li>• Verificare tutti i collegamenti e sostituire tutte le coperture prima dell'accensione</li> </ul> <p><b>L'omissione di queste istruzioni provocherà la morte o lesioni serie</b></p>	<p><b>存在电击、爆炸或电弧闪烁危险</b></p> <ul style="list-style-type: none"> <li>• 在操作此设备之前请先关闭电源。</li> </ul> <p><b>若不遵守这些说明,可能会导致严重的人身伤害甚至死亡。</b></p>
--	--	---	--	--	---

**⚠ WARNING / AVERTISSEMENT / WARNUNG /ADVERTENCIA / AVVERTENZA / 警告**

<p><b>RISK OF MATERIAL DAMAGE AND HOT ENCLOSURE</b></p> <ul style="list-style-type: none"> <li>• The product's side panels may be hot, allow the product to cool before touching.</li> <li>• Follow proper mounting instructions including torque values.</li> <li>• Do not allow liquids or foreign objects to enter this product.</li> </ul> <p><b>Failure to follow these instructions can result in serious injury, or equipment damage.</b></p>	<p><b>RISQUE DE DOMMAGE MATERIEL ET DE SURCHAUFFE DU BOITIER</b></p> <ul style="list-style-type: none"> <li>• Les panneaux latéraux du produit peuvent être chauds. Laisser le produit refroidir avant de le toucher.</li> <li>• Respecter les consignes de montage, et notamment les couples de serrage.</li> <li>• Ne pas laisser pénétrer de liquide ni de corps étrangers à l'intérieur du produit.</li> </ul> <p><b>Le non-respect de cette directive peut entraîner, des lésions corporelles graves ou des dommages matériels.</b></p>	<p><b>GEFAHR VON MATERIALSCHÄDEN UND GEHÄUSEERHITZUNG</b></p> <ul style="list-style-type: none"> <li>• Die Seitenwände können heiß sein. Lassen Sie das Produkt abkühlen, bevor Sie es berühren.</li> <li>• Beachten Sie die Montageanweisungen,</li> <li>• Führen Sie keine Flüssigkeiten oder Fremdkörper in das Produkt ein.</li> </ul> <p><b>Die Nichtbeachtung dieser Anweisung kann Körperverletzung oder Materialschäden zur Folge haben.</b></p>
<p><b>RIESGO DE DAÑOS MATERIALES Y DE SOBRECALENTAMIENTO DE LA UNIDAD</b></p> <ul style="list-style-type: none"> <li>• Los paneles laterales del producto pueden estar calientes. Esperar que el producto se enfríe antes de tocarlo.</li> <li>• Respetar las instrucciones de montaje, y en particular los pares de apretado.</li> <li>• No dejar que penetren líquidos o cuerpos extraños en el producto.</li> </ul> <p><b>Si no se respetan estas precauciones pueden producirse graves lesiones, daños materiales.</b></p>	<p><b>RISCHIO DI DANNI MATERIALI E D'INVOLUCRO CALDO</b></p> <ul style="list-style-type: none"> <li>• I pannelli laterali dell'apparecchio possono scottare; lasciar quindi raffreddare il prodotto prima di toccarlo.</li> <li>• Seguire le istruzioni di montaggio corrette.</li> <li>• Non far entrare liquidi o oggetti estranei in questo apparecchio.</li> </ul> <p><b>La mancata osservanza di questa precauzione può causare gravi rischi per l'incolumità personale o danni alle apparecchiature.</b></p>	<p><b>材料损坏和高温外壳的危险性</b></p> <ul style="list-style-type: none"> <li>• 产品的一侧面板可能很热, 在其冷却前请不要触碰。</li> <li>• 遵照正确的安装说明, 包括扭矩值。</li> <li>• 请勿让液体及其他异物进入本产品。</li> </ul> <p><b>如不能正确执行这些操作说明, 极有可能造成严重人体伤害或者设备的损坏。</b></p>

**ANNEX - ENVIRONMENTAL INFORMATION**

The environmental information disclosed in this annex including the EIP Pollution logo are in compliance with People’s Republic of China Electronic Industry Standard SJ/T11364 – 2006, Marking for Control of Pollution Caused by Electronic Information Products.

Part Name	Toxic or hazardous Substance and Elements					
	Lead (Pb)	Mercury (Hg)	Cadmium (Cd)	Hexavalent Chromium (Cr (VI))	Polybrominated biphenyls (PBB)	Polybrominated diphenyl ethers (PBDE)
Semiconductor die	X	○	○	○	○	○
Solder	X	○	○	○	○	○

附件 – 环保信息

此附件所标示的包括电子信息产品污染图标的环保信息符合中华人民共和国电子行业标准 SJ/T11364 - 2006, 电子信息产品污染控制标识要求。

部件名称	有毒有害物质或元素					
	铅 (Pb)	汞 (Hg)	镉 (Cd)	六价铬 (Cr (VI))	多溴联苯 (PBB)	多溴二苯醚 (PBDE)
半导体芯片	X	○	○	○	○	○
焊接点	X	○	○	○	○	○





**Стандарт  
Электрон  
Связь**

Мы молодая и активно развивающаяся компания в области поставок электронных компонентов. Мы поставляем электронные компоненты отечественного и импортного производства напрямую от производителей и с крупнейших складов мира.

Благодаря сотрудничеству с мировыми поставщиками мы осуществляем комплексные и плановые поставки широчайшего спектра электронных компонентов.

Собственная эффективная логистика и склад в обеспечивает надежную поставку продукции в точно указанные сроки по всей России.

Мы осуществляем техническую поддержку нашим клиентам и предпродажную проверку качества продукции. На все поставляемые продукты мы предоставляем гарантию .

Осуществляем поставки продукции под контролем ВП МО РФ на предприятия военно-промышленного комплекса России , а также работаем в рамках 275 ФЗ с открытием отдельных счетов в уполномоченном банке. Система менеджмента качества компании соответствует требованиям ГОСТ ISO 9001.

Минимальные сроки поставки, гибкие цены, неограниченный ассортимент и индивидуальный подход к клиентам являются основой для выстраивания долгосрочного и эффективного сотрудничества с предприятиями радиоэлектронной промышленности, предприятиями ВПК и научно-исследовательскими институтами России.

С нами вы становитесь еще успешнее!

**Наши контакты:**

**Телефон:** +7 812 627 14 35

**Электронная почта:** [sales@st-electron.ru](mailto:sales@st-electron.ru)

**Адрес:** 198099, Санкт-Петербург,  
Промышленная ул, дом № 19, литера Н,  
помещение 100-Н Офис 331