



MAX9921 Evaluation Kit

General Description

The MAX9921 evaluation kit (EV kit) is a fully assembled and tested PCB that demonstrates the capabilities of the MAX9921 dual 2-wire Hall-effect sensor interface with diagnostics capability. The EV kit comes with the MAX9921AUB+ installed.

Features

- ◆ 6V to 18V Operating Voltage Range, Survives 60V
- ◆ Two 2-Wire Hall-Effect Sensors on the Board
- ◆ Three Output Status LED Indicators
- ◆ Proven PCB Layout
- ◆ Fully Assembled and Tested

Ordering Information

PART	TYPE
MAX9921EVKIT+	EV Kit

+Denotes lead-free and RoHS compliant.

Component List

DESIGNATION	QTY	DESCRIPTION
C1, C3	2	0.01 μ F \pm 10%, 100V X7R ceramic capacitors (0603) TDK C1608X7R2A103K
C2, C4	0	Not installed, capacitors
C5, C6, C7	3	0.1 μ F \pm 10%, 100V X7R ceramic capacitors (0805) TDK C2012X7R2A104K
C8	1	1 μ F \pm 10%, 25V X5R ceramic capacitor (0805) TDK C2012X5R1E105K
C9	1	2.2 μ F \pm 10%, 100V X5R ceramic capacitor (1812) TDK C4532X7R2A225K
D1	1	100V, 200mA diode (SOD123) Central CMHD4448
D2, D3	2	Green LEDs (0603)
D4	1	Red LED (0603)
J1	0	Not installed

DESIGNATION	QTY	DESCRIPTION
JU1, JU2	2	5-pin, 4-way headers
JU3–JU7	5	2-pin headers
R1	1	63.4k Ω \pm 1% resistor (0603)
R2–R5	4	100k Ω \pm 5% resistors (0603)
R6, R7, R8	3	240 Ω \pm 5% resistors (0603)
S1, S2	2	Hall-effect switches Allegro A1140EUA
S3, S4	0	Not installed, switches
U1	1	Automotive Hall-effect interface (10 μ MAX [®]) Maxim MAX9921AUB+
U2	1	Automotive micropower linear regulator (6 TDFN) Maxim MAX6765TTLD2+
U3	1	Triple-buffer gate (8 TSSOP)
—	7	Shunts
—	1	PCB: MAX9921 Evaluation Kit+

Component Suppliers

SUPPLIER	PHONE	WEBSITE
Central Semiconductor Corp.	631-435-1110	www.centralsemi.com
TDK Corp.	847-803-6100	www.component.tdk.com

Note: Indicate that you are using the MAX9921 when contacting these component suppliers.

μ MAX is a registered trademark of Maxim Integrated Products, Inc.



Maxim Integrated Products 1

For pricing, delivery, and ordering information, please contact Maxim Direct at 1-888-629-4642, or visit Maxim's website at www.maxim-ic.com.

Evaluates: MAX9921

MAX9921 Evaluation Kit

Quick Start

Recommended Equipment

Before beginning, the following equipment is needed:

- MAX9921 EV kit
- One 6V to 18V DC power supply
- A magnet

Procedure

The MAX9921 EV kit is fully assembled and tested. Follow the steps below to verify board operation.

Caution: Do not turn on the power supply until all connections are made.

- 1) Verify that all jumpers are in the default positions, as shown in Table 1.
- 2) Connect the DC power supply between the MAX9921 EV kit's VBAT and GND pads.
- 3) Turn on the DC power supply.
- 4) Move the magnet in front of S1 and S2. Observe the light change of the OUT1 and OUT2 LEDs on the EV kit board.

Detailed Description of Hardware

The MAX9921 EV kit board provides a proven layout for evaluating the MAX9921. The EV kit comes with MAX9921AUB+ installed.

External Power Supply

The MAX9921 is powered by a user-supplied 6V to 18V DC power supply connecting between VBAT and GND. The MAX9921 EV kit board is not **reverse-battery** protected.

During the emulation of the Hall input shorted to GND, the MAX9921 will draw substantial shorting current until the MAX9921 turns off the shorted input. The shorting current can reach a peak of 60mA to 70mA and the entire event may last 0.5 μ s. Many common regulated-lab power supplies will overshoot in response to a large, short-term current pulse. When evaluating the short-to-GND fault, an unregulated supply is recommended, such as a wet-cell battery.

Hall-Effect Sensors and Related Jumpers

The MAX9921 EV kit has two Hall-effect sensors (A1140EUA). JU1 and JU2 provide a convenient way to evaluate the MAX9921 with different Hall-effect sensors and emulate different failure conditions, as shown in Table 1.

Table 1. MAX9921 EV KIT Jumper Descriptions (JU1-JU7)

JUMPER	POSITION	DESCRIPTION
JU1, JU2	1-2	Emulates Hall input shorted to battery
	1-3*	Demonstrates normal operation with on-board Hall sensor
	1-4	Emulates Hall input shorted to GND
	1-5	Evaluates other Hall sensors
	Open	Emulates the open-circuit failure
JU3	1-2*	Outputs enabled
	Open	Outputs disabled
JU4	1-2	Outputs reflect diagnostic information
	Open*	Outputs reflect Hall sensor information
JU5	1-2*	OUT1 with 100k Ω pullup
	Open	OUT1 without pullup
JU6	1-2*	OUT2 with 100k Ω pullup
	Open	OUT2 without pullup
JU7	1-2*	$\overline{\text{ERR}}$ with 100k Ω pullup
	Open	$\overline{\text{ERR}}$ without pullup

*Default position.

DIAG and OE Configuration

The MAX9921 EV kit uses JU3 and JU4 to configure the MAX9921 DIAG and OE inputs, as shown in Table 1. Refer to the MAX9921 IC data sheet for a detailed description of the MAX9921 diagnostic information.

Outputs, Related LEDs, and Jumpers

The MAX9921 EV kit has three outputs: OUT1, OUT2, and $\overline{\text{ERR}}$. Each output has an LED to indicate its current status. All three outputs can be individually pulled up with a 100k Ω resistor, as shown in Table 1. Refer to the MAX9921 IC data sheet for a detailed description of OUT1, OUT2, and $\overline{\text{ERR}}$ outputs.

MAX9921 Evaluation Kit

Evaluates: MAX9921

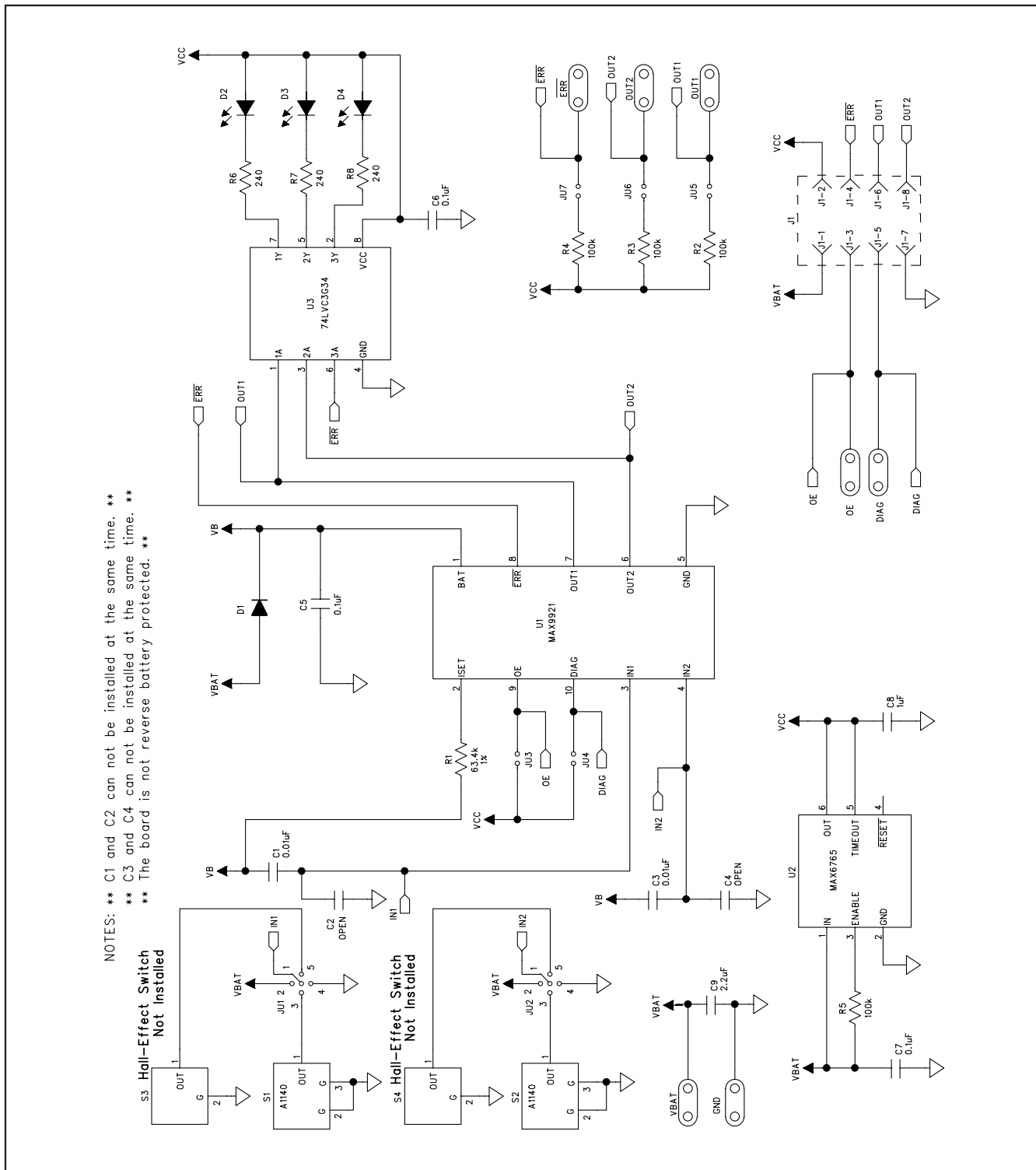

NOTES: ** C1 and C2 can not be installed at the same time. **
 ** C3 and C4 can not be installed at the same time. **
 ** The board is not reverse battery protected. **

Figure 1. MAX9921 EV Kit Schematic

MAX9921 Evaluation Kit

Evaluates: MAX9921

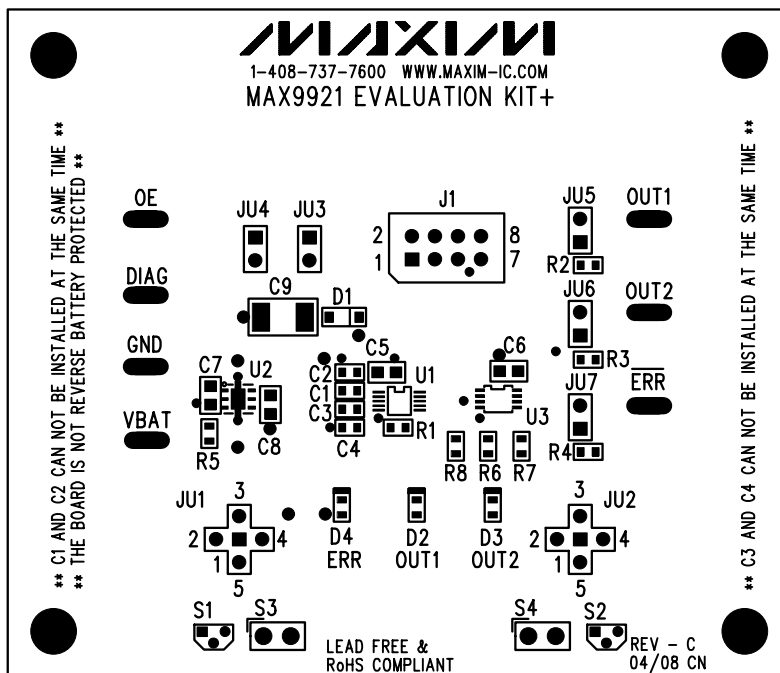

Figure 2. MAX9921 EV Kit Component Placement Guide—Component Side

MAX9921 Evaluation Kit

Evaluates: MAX9921

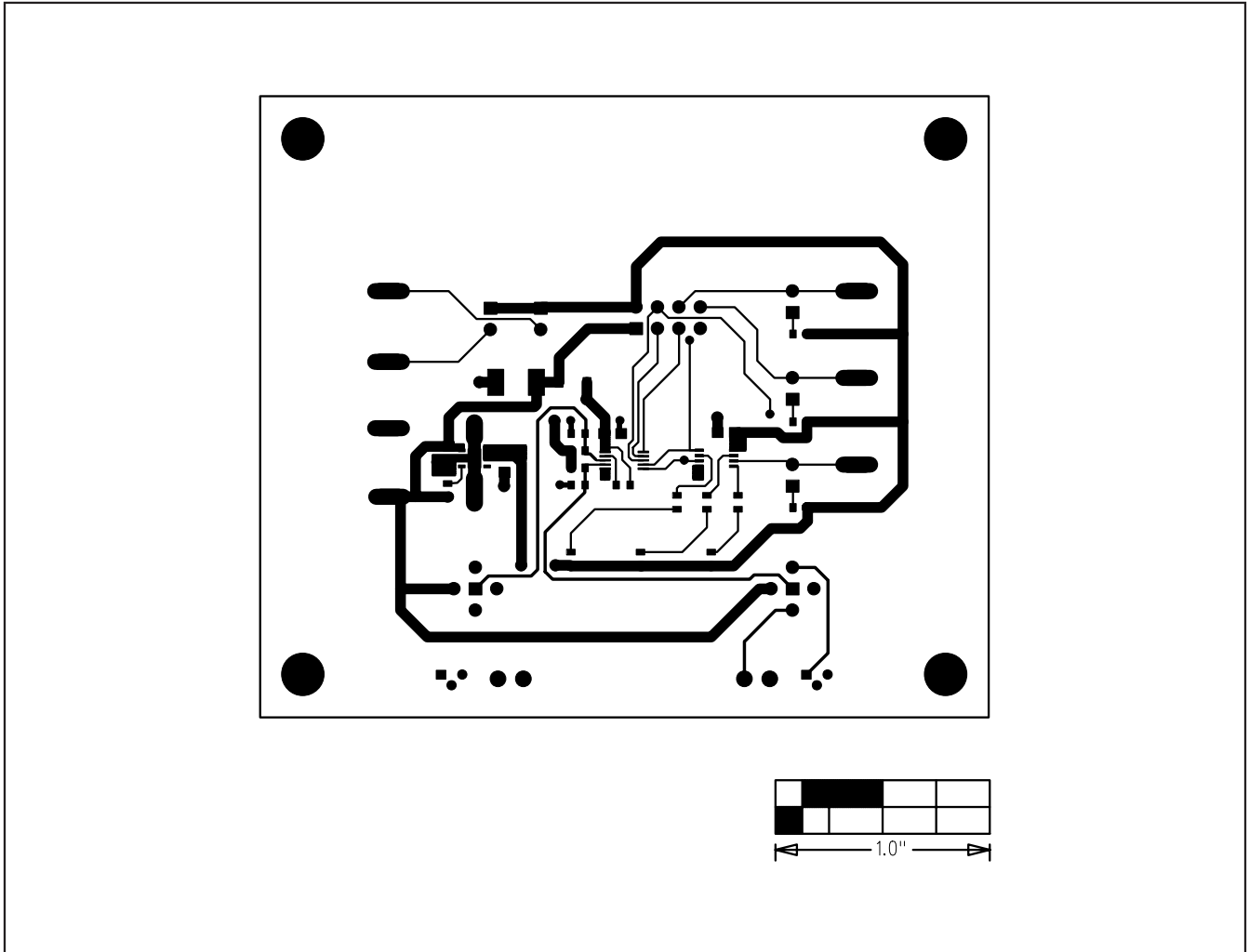

Figure 3. MAX9921 EV Kit PCB Layout—Component Side

MAX9921 Evaluation Kit

Evaluates: MAX9921

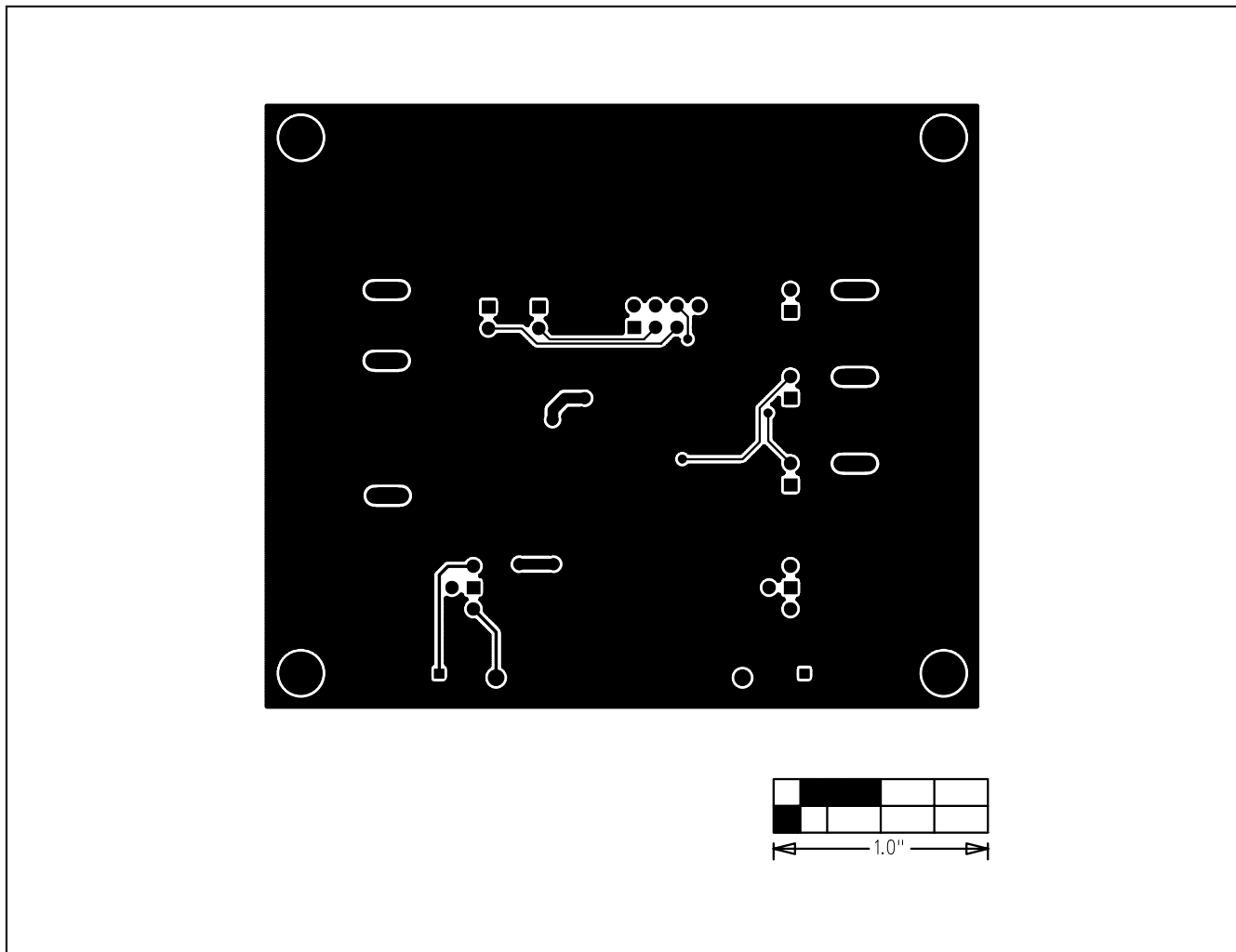

Figure 4. MAX9921 EV Kit PCB Layout—Solder Side

Maxim cannot assume responsibility for use of any circuitry other than circuitry entirely embodied in a Maxim product. No circuit patent licenses are implied. Maxim reserves the right to change the circuitry and specifications without notice at any time.

6 **Maxim Integrated Products, 120 San Gabriel Drive, Sunnyvale, CA 94086 408-737-7600**

© 2008 Maxim Integrated Products

MAXIM is a registered trademark of Maxim Integrated Products, Inc.



**Стандарт
Электрон
Связь**

Мы молодая и активно развивающаяся компания в области поставок электронных компонентов. Мы поставляем электронные компоненты отечественного и импортного производства напрямую от производителей и с крупнейших складов мира.

Благодаря сотрудничеству с мировыми поставщиками мы осуществляем комплексные и плановые поставки широчайшего спектра электронных компонентов.

Собственная эффективная логистика и склад в обеспечивает надежную поставку продукции в точно указанные сроки по всей России.

Мы осуществляем техническую поддержку нашим клиентам и предпродажную проверку качества продукции. На все поставляемые продукты мы предоставляем гарантию .

Осуществляем поставки продукции под контролем ВП МО РФ на предприятия военно-промышленного комплекса России , а также работаем в рамках 275 ФЗ с открытием отдельных счетов в уполномоченном банке. Система менеджмента качества компании соответствует требованиям ГОСТ ISO 9001.

Минимальные сроки поставки, гибкие цены, неограниченный ассортимент и индивидуальный подход к клиентам являются основой для выстраивания долгосрочного и эффективного сотрудничества с предприятиями радиоэлектронной промышленности, предприятиями ВПК и научно-исследовательскими институтами России.

С нами вы становитесь еще успешнее!

Наши контакты:

Телефон: +7 812 627 14 35

Электронная почта: sales@st-electron.ru

Адрес: 198099, Санкт-Петербург,
Промышленная ул, дом № 19, литера Н,
помещение 100-Н Офис 331