



MCP6XXX Amplifier Evaluation Board 4 User's Guide

Note the following details of the code protection feature on Microchip devices:

- Microchip products meet the specification contained in their particular Microchip Data Sheet.
- Microchip believes that its family of products is one of the most secure families of its kind on the market today, when used in the intended manner and under normal conditions.
- There are dishonest and possibly illegal methods used to breach the code protection feature. All of these methods, to our knowledge, require using the Microchip products in a manner outside the operating specifications contained in Microchip's Data Sheets. Most likely, the person doing so is engaged in theft of intellectual property.
- Microchip is willing to work with the customer who is concerned about the integrity of their code.
- Neither Microchip nor any other semiconductor manufacturer can guarantee the security of their code. Code protection does not mean that we are guaranteeing the product as "unbreakable."

Code protection is constantly evolving. We at Microchip are committed to continuously improving the code protection features of our products. Attempts to break Microchip's code protection feature may be a violation of the Digital Millennium Copyright Act. If such acts allow unauthorized access to your software or other copyrighted work, you may have a right to sue for relief under that Act.

Information contained in this publication regarding device applications and the like is provided only for your convenience and may be superseded by updates. It is your responsibility to ensure that your application meets with your specifications. MICROCHIP MAKES NO REPRESENTATIONS OR WARRANTIES OF ANY KIND WHETHER EXPRESS OR IMPLIED, WRITTEN OR ORAL, STATUTORY OR OTHERWISE, RELATED TO THE INFORMATION, INCLUDING BUT NOT LIMITED TO ITS CONDITION, QUALITY, PERFORMANCE, MERCHANTABILITY OR FITNESS FOR PURPOSE. Microchip disclaims all liability arising from this information and its use. Use of Microchip devices in life support and/or safety applications is entirely at the buyer's risk, and the buyer agrees to defend, indemnify and hold harmless Microchip from any and all damages, claims, suits, or expenses resulting from such use. No licenses are conveyed, implicitly or otherwise, under any Microchip intellectual property rights.

Trademarks

The Microchip name and logo, the Microchip logo, Accuron, dsPIC, KEELOQ, KEELOQ logo, microID, MPLAB, PIC, PICmicro, PICSTART, PRO MATE, rPIC and SmartShunt are registered trademarks of Microchip Technology Incorporated in the U.S.A. and other countries.

AmpLab, FilterLab, Linear Active Thermistor, Migratable Memory, MXDEV, MXLAB, SEEVAL, SmartSensor and The Embedded Control Solutions Company are registered trademarks of Microchip Technology Incorporated in the U.S.A.

Analog-for-the-Digital Age, Application Maestro, CodeGuard, dsPICDEM, dsPICDEM.net, dsPICworks, dsSPEAK, ECAN, ECONOMONITOR, FanSense, FlexROM, fuzzyLAB, In-Circuit Serial Programming, ICSP, ICEPIC, Mindi, MiWi, MPASM, MPLAB Certified logo, MPLIB, MPLINK, PCKit, PICDEM, PICDEM.net, PICLAB, PICTail, PowerCal, PowerInfo, PowerMate, PowerTool, REAL ICE, rLAB, Select Mode, Smart Serial, SmartTel, Total Endurance, UNI/O, WiperLock and ZENA are trademarks of Microchip Technology Incorporated in the U.S.A. and other countries.

SQTP is a service mark of Microchip Technology Incorporated in the U.S.A.

All other trademarks mentioned herein are property of their respective companies.

© 2007, Microchip Technology Incorporated, Printed in the U.S.A., All Rights Reserved.

 Printed on recycled paper.

**QUALITY MANAGEMENT SYSTEM
CERTIFIED BY DNV
== ISO/TS 16949:2002 ==**

Microchip received ISO/TS-16949:2002 certification for its worldwide headquarters, design and wafer fabrication facilities in Chandler and Tempe, Arizona; Gresham, Oregon and design centers in California and India. The Company's quality system processes and procedures are for its PIC® MCUs and dsPIC® DSCs, KEELOQ® code hopping devices, Serial EEPROMs, microperipherals, nonvolatile memory and analog products. In addition, Microchip's quality system for the design and manufacture of development systems is ISO 9001:2000 certified.



MCP6XXX AMPLIFIER EVALUATION BOARD 4 USER'S GUIDE

Table of Contents

Preface	1
Introduction.....	1
Document Layout	1
Conventions Used in this Guide	2
Recommended Reading.....	3
The Microchip Web Site	3
Customer Support	3
Document Revision History	3
Chapter 1. Product Overview	5
1.1 Introduction	5
1.2 MCP6XXX Amplifier Evaluation Board 4 Kit Contents	5
1.3 MCP6XXX Amplifier Evaluation Board 4 Description	6
Chapter 2. Installation and Operation	7
2.1 Introduction	7
2.2 Required Tools	7
2.3 MCP6XXX Amplifier Evaluation Board 4 Set-up	7
2.4 MCP6XXX Amplifier Evaluation Board 4 Operation	11
Appendix A. Schematic and Layouts	17
A.1 Introduction	17
A.2 Board - Schematic	18
A.3 Board - Top Silk and Metal Layers	19
A.4 Board - Top Metal Layer	20
A.5 Board - Bottom Metal Layer	21
Appendix B. Bill of Materials (BOM)	23
B.1 MCP6XXX Amplifier Evaluation Board 4 BOM	23
Worldwide Sales and Service	27

MCP6XXX Amplifier Evaluation Board 4 User's Guide

NOTES:



MCP6XXX AMPLIFIER EVALUATION BOARD 4 USER'S GUIDE

Preface

NOTICE TO CUSTOMERS

All documentation becomes dated, and this manual is no exception. Microchip tools and documentation are constantly evolving to meet customer needs, so some actual dialogs and/or tool descriptions may differ from those in this document. Please refer to our web site (www.microchip.com) to obtain the latest documentation available.

Documents are identified with a "DS" number. This number is located on the bottom of each page, in front of the page number. The numbering convention for the DS number is "DSXXXXA", where "XXXX" is the document number and "A" is the revision level of the document.

For the most up-to-date information on development tools, see the MPLAB® IDE on-line help. Select the Help menu, and then Topics to open a list of available on-line help files.

INTRODUCTION

This chapter contains general information that will be useful to know before using the MCP6XXX Amplifier Evaluation Board 4. Items discussed in this chapter include:

- Document Layout
- Conventions Used in this Guide
- Recommended Reading
- The Microchip Web Site
- Customer Support
- Document Revision History

DOCUMENT LAYOUT

This document describes how to use the MCP6XXX Amplifier Evaluation Board 4. The manual layout is as follows:

- **Chapter 1. "Product Overview"** - Provides the important information about the MCP6XXX Amplifier Evaluation Board 4.
- **Chapter 2. "Installation and Operation"** – Covers the installation and operation of the MCP6XXX Amplifier Evaluation Board 4. It lists the required tools, shows how to set up the board, and demonstrates how to verify the amplifier operation.
- **Appendix A. "Schematic and Layouts"** – Shows the schematic and board layouts for the MCP6XXX Amplifier Evaluation Board 4.
- **Appendix B. "Bill of Materials (BOM)"** – Lists the parts used to build the MCP6XXX Amplifier Evaluation Board 4.

MCP6XXX Amplifier Evaluation Board 4 User's Guide

CONVENTIONS USED IN THIS GUIDE

This manual uses the following documentation conventions:

DOCUMENTATION CONVENTIONS

Description	Represents	Examples
Arial font:		
Italic characters	Referenced books	<i>MPLAB® IDE User's Guide</i>
	Emphasized text	...is the <i>only</i> compiler...
Initial caps	A window	the Output window
	A dialog	the Settings dialog
	A menu selection	select Enable Programmer
Quotes	A field name in a window or dialog	"Save project before build"
Underlined, italic text with right angle bracket	A menu path	<u><i>File>Save</i></u>
Bold characters	A dialog button	Click OK
	A tab	Click the Power tab
N'Rnnnn	A number in verilog format, where N is the total number of digits, R is the radix and n is a digit.	4'b0010, 2'hF1
Text in angle brackets < >	A key on the keyboard	Press <Enter>, <F1>
Courier New font:		
Plain Courier New	Sample source code	#define START
	Filenames	autoexec.bat
	File paths	c:\mcc18\h
	Keywords	_asm, _endasm, static
	Command-line options	-Opa+, -Opa-
	Bit values	0, 1
	Constants	0xFF, 'A'
Italic Courier New	A variable argument	<i>file.o</i> , where <i>file</i> can be any valid filename
Square brackets []	Optional arguments	mcc18 [options] <i>file</i> [options]
Curly brackets and pipe character: { }	Choice of mutually exclusive arguments; an OR selection	errorlevel {0 1}
Ellipses...	Replaces repeated text	var_name [, var_name...]
	Represents code supplied by user	void main (void) { ... }

RECOMMENDED READING

This user's guide describes how to use MCP6XXX Amplifier Evaluation Board 4. Other useful documents are listed below. The following Microchip documents are available and recommended as supplemental reference resources.

MCP6021/2/3/4 Data Sheet, “Rail-to-Rail Input/Output, 10 MHz Op Amps” (DS21685)

This data sheet provides detailed information regarding the MCP602X product family.

THE MICROCHIP WEB SITE

Microchip provides online support via our web site at www.microchip.com. This web site is used as a means to make files and information easily available to customers. Accessible by using your favorite Internet browser, the web site contains the following information:

- **Product Support** – Data sheets and errata, application notes and sample programs, design resources, user's guides and hardware support documents, latest software releases and archived software
- **General Technical Support** – Frequently Asked Questions (FAQs), technical support requests, online discussion groups, Microchip consultant program member listing
- **Business of Microchip** – Product selector and ordering guides, latest Microchip press releases, listing of seminars and events, listings of Microchip sales offices, distributors and factory representatives

CUSTOMER SUPPORT

Users of Microchip products can receive assistance through several channels:

- Distributor or Representative
- Local Sales Office
- Field Application Engineer (FAE)
- Technical Support
- Development Systems Information Line

Customers should contact their distributor, representative or field application engineer for support. Local sales offices are also available to help customers. A listing of sales offices and locations is included in the back of this document.

Technical support is available through the web site at: <http://support.microchip.com>

DOCUMENT REVISION HISTORY

Revision A (August 2007)

- Initial Release of this Document.

MCP6XXX Amplifier Evaluation Board 4 User's Guide

NOTES:

Chapter 1. Product Overview

1.1 INTRODUCTION

The MCP6XXX Amplifier Evaluation Board 4 is described by the following:

- Assembly # : 114-00154
- Order # : MCP6XXXEV-AMP4
- Name: MCP6XXX Amplifier Evaluation Board 4

Items discussed in this chapter include:

- **Section 1.2 “MCP6XXX Amplifier Evaluation Board 4 Kit Contents”**
- **Section 1.3 “MCP6XXX Amplifier Evaluation Board 4 Description”**

1.2 MCP6XXX AMPLIFIER EVALUATION BOARD 4 KIT CONTENTS

- MCP6XXX Amplifier Evaluation Board 4 - One partially assembled board
- Important Information “Read First”
- Accessory Bag - Contains loose parts for populating sockets on board
- Analog and Interface Products Demonstration Boards CD-ROM (DS21912)
 - MCP6XXX Amplifier Evaluation Board 4 User's Guide (DS51681)



FIGURE 1-1: MCP6XXX Amplifier Evaluation Board 4 Kit.

MCP6XXX Amplifier Evaluation Board 4 User's Guide

1.3 MCP6XXX AMPLIFIER EVALUATION BOARD 4 DESCRIPTION

MCP6XXX Amplifier Evaluation Board 4 is intended to support the inverting integrator circuit.

The MCP6XXX Amplifier Evaluation Board 4 has the following features:

- All amplifier resistors and capacitors are socketed
- Supports all Microchip single op amps
 - PDIP-8 package (e.g., MCP6021) are socketed
 - SOIC-8 package can be accommodated; see **Section 2.4.3 “Amplifier Modifications Using 8-Pin SOIC Op Amps”**
- Test points for connecting lab equipment
- Single supply configuration

Figure 1-2 shows the block diagram of the MCP6XXX Amplifier Evaluation Board 4. Lab equipment can be attached (via test points) to measure the amplifier response.

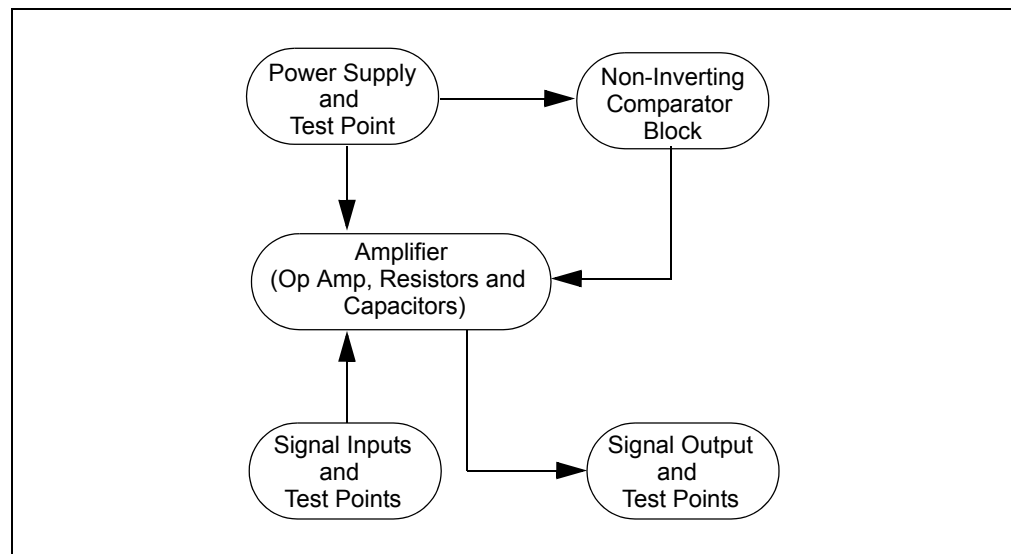

FIGURE 1-2: MCP6XXX Amplifier Evaluation Board 4 Block Diagram.

Chapter 2. Installation and Operation

2.1 INTRODUCTION

This chapter shows how to set up the MCP6XXX Amplifier Evaluation Board 4 and verify its operation. This chapter includes the following topics:

- Required Tools
- MCP6XXX Amplifier Evaluation Board 4 Set-Up
- MCP6XXX Amplifier Evaluation Board 4 Operation

2.2 REQUIRED TOOLS

- Lab power supply
- Lab signal source (e.g., function generator)
- Lab measurement equipment (e.g., oscilloscope)

2.3 MCP6XXX AMPLIFIER EVALUATION BOARD 4 SET-UP

The MCP6XXX Amplifier Evaluation Board 4 is designed to demonstrate an inverting integrator using one op amp and supporting circuitry. This section details the conversion of the topology to the MCP6XXX Amplifier Evaluation Board 4. Figure 2-1 shows the circuit diagram for the board.

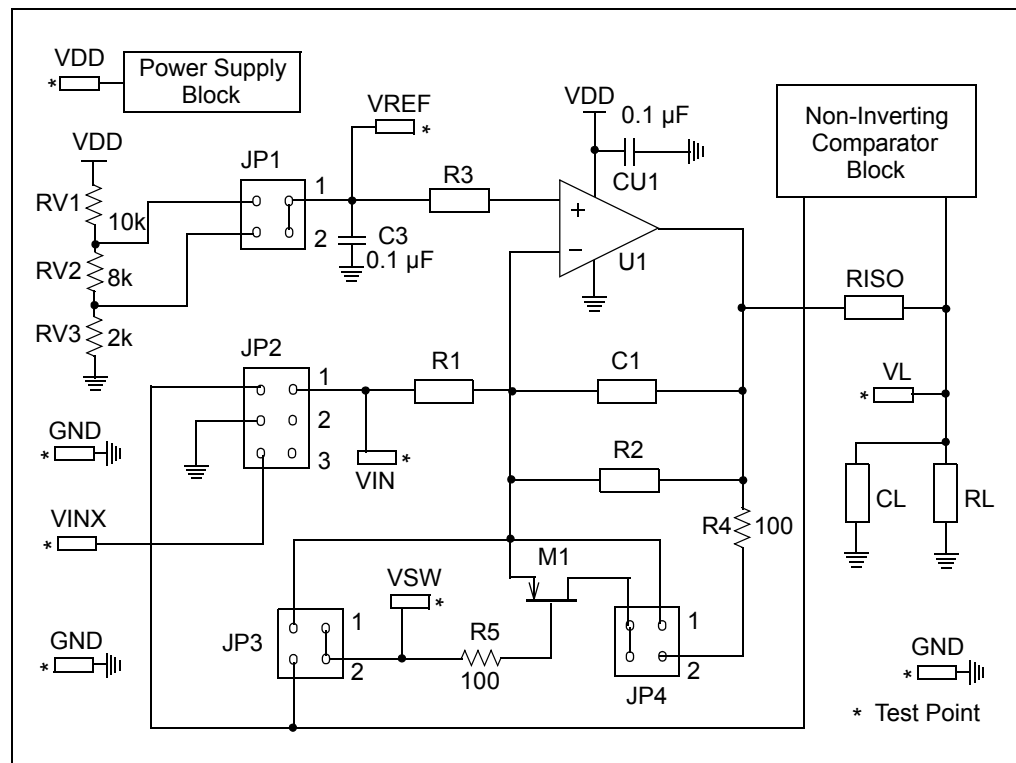

FIGURE 2-1: MCP6XXX Amplifier Evaluation Board 4 Circuit Diagram.

MCP6XXX Amplifier Evaluation Board 4 User's Guide

The power supply voltage needs to be in the allowed range for the installed operational amplifiers. Any of Microchip's op amps that operate below 5.5V can be used. Moreover, the power supply is protected by a zener diode with nominal voltage 6.2V and bypassed by a 1.0 μF capacitor. (See **Figure 2-3: "Power Supply Block."**)

The output load consists of a capacitor (C_L) and two resistors (R_L , R_{ISO}). R_{ISO} is used to stabilize the amplifier when it drives a large capacitive load. R_{ISO} is a short circuit (0Ω) when C_L is small.

The non-inverting comparator provides two trip points which are at $0.8V_{DD}$ and $0.2V_{DD}$. (See **Section Figure 2-4: "Non-Inverting Comparator Block."**)

The resistors that are part of an amplifier are placed in pin sockets which are labeled. The op amps are bypassed by 0.1 μF capacitors and the single op amp U1 can have either a PDIP-8 or SOIC-8 package.

- PDIP-8 packages are inserted into the DIP-8 socket to the right of the U1 label.
- SOIC-8 packages can be accommodated; see **Section 2.4.3 "Amplifier Modifications Using 8-Pin SOIC Op Amps"**.

The (surface mount) test points for power supply, ground, input signal and output signal allow lab equipment to be connected to the board. The MCP6XXX Amplifier Evaluation Board 4 top view is shown in Figure 2-2.

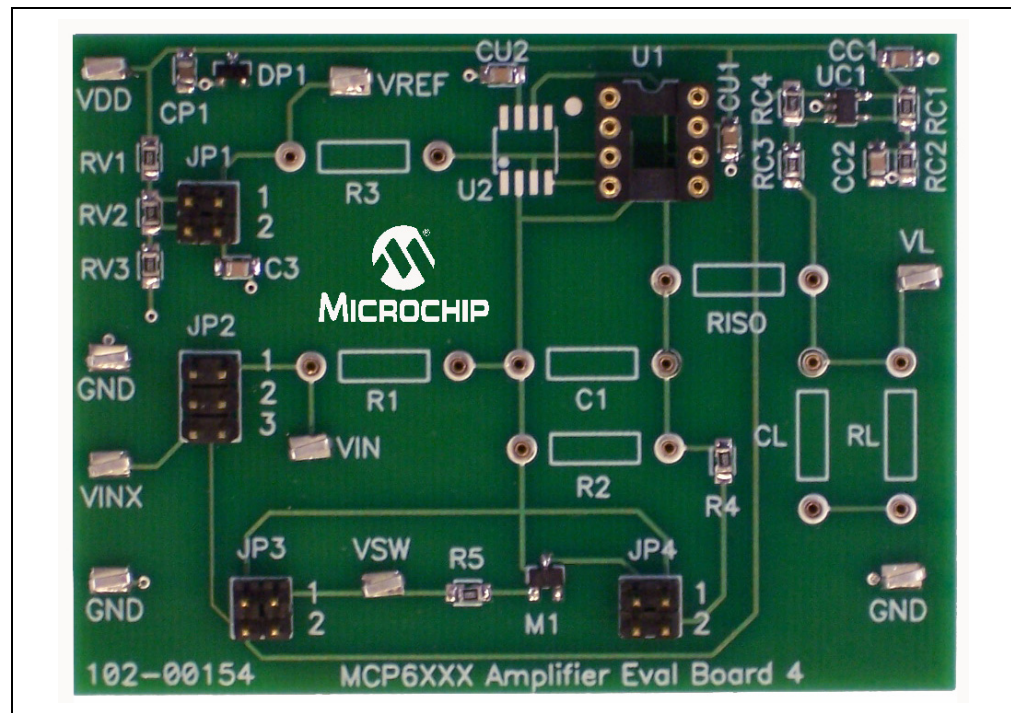

FIGURE 2-2: MCP6XXX Amplifier Evaluation Board 4 Top View.

2.3.1 Top Level Amplifier Circuit Diagrams

2.3.1.1 POWER SUPPLY BLOCK

The power supply is protected by a zener diode and bypassed by a capacitor. Figure 2-3 shows the circuit diagram for the power supply. $C_{P1} = 1.0 \mu\text{F}$.

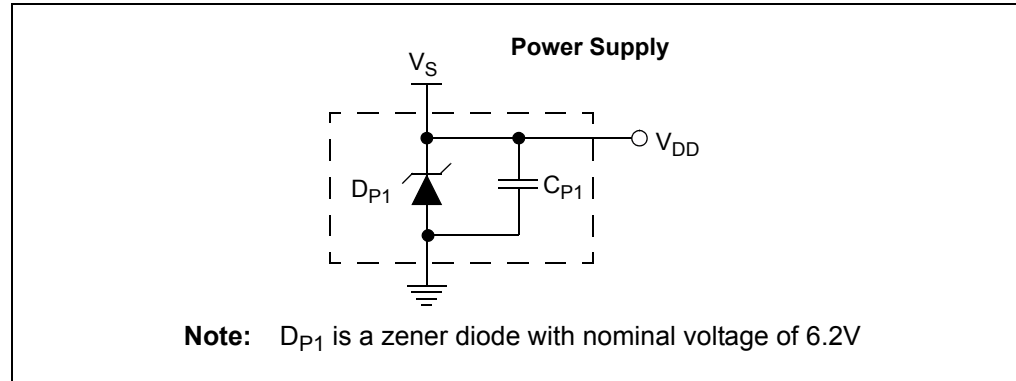

FIGURE 2-3: Power Supply Block.

2.3.1.2 NON-INVERTING COMPARATOR

Figure 2-4 shows the circuit diagram for the non-inverting comparator block. The non-inverting comparator's trip points are $0.8V_{DD}$ and $0.2V_{DD}$.

$R_{C1} = R_{C2} = 10.0 \text{ k}\Omega$, $R_{C3} = 30.0 \text{ k}\Omega$, $R_{C4} = 50.0 \text{ k}\Omega$, $C_{C1} = C_{C2} = 0.1 \mu\text{F}$.

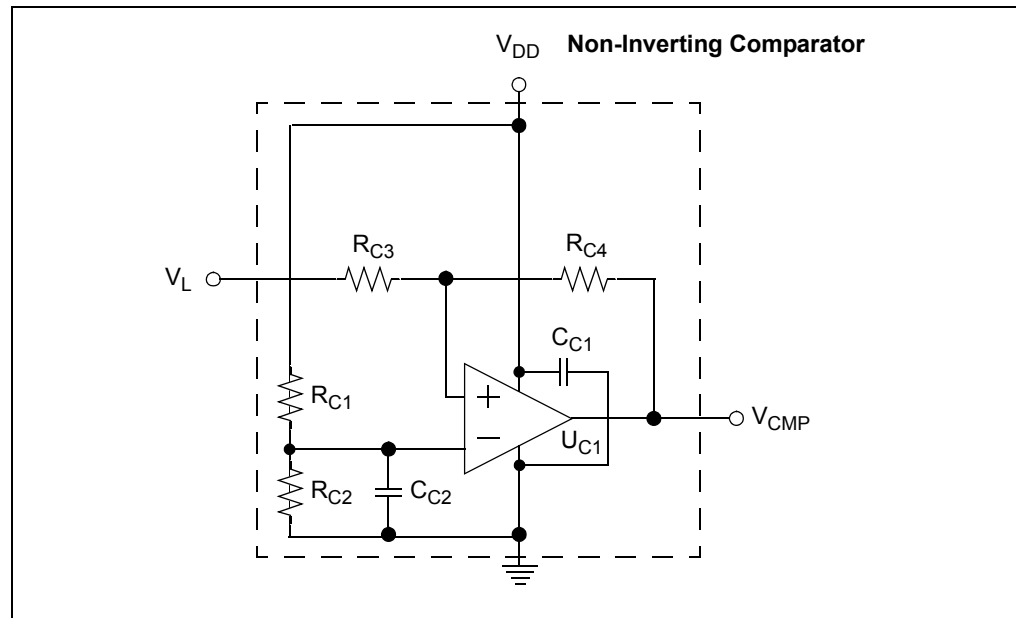

FIGURE 2-4: Non-Inverting Comparator Block.

MCP6XXX Amplifier Evaluation Board 4 User's Guide

2.3.2 Inverting Integrator

- It integrates and inverts a voltage with an integrating frequency $\omega = 1/R_1C_1$ (rad/s). Additional components control output clipping (wind-up) and initialization of the integrating capacitor (C_1). Refer to Figure 2-1.
- Figure 2-5 shows the circuit diagram for the inverting integrator block.
 $C_{U1} = 0.1 \mu\text{F}$, $R_4 = R_5 = 100.0\Omega$, M_1 is N-MOSFET, $R_3 = R_1//R_2$

- Note 1:** Adding R_2 to avoid the integrator output clipping at DC.
2: Adding R_3 to minimize the output error due to the input bias current

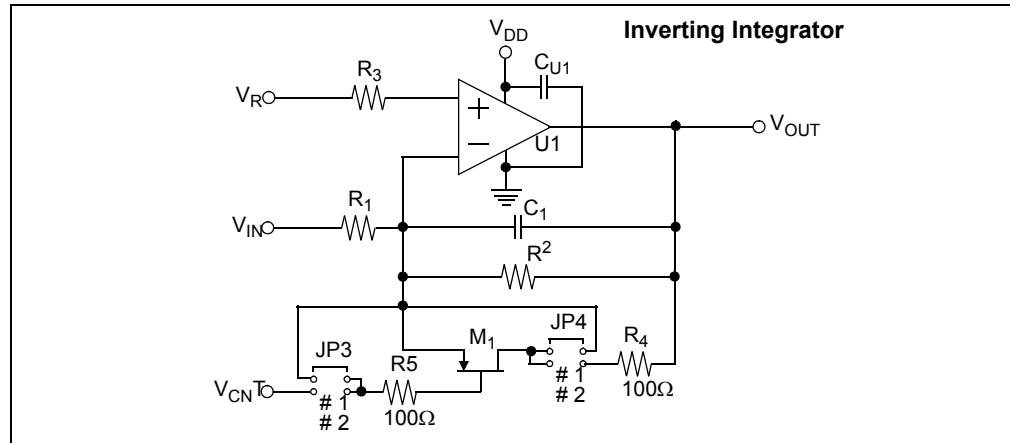

FIGURE 2-5: Inverting Integrator Block.

Table 2-1 shows the jumper positions and the corresponding effects

TABLE 2-1: JUMPER POSITIONS AND EFFECTS

Jumper	Position	Effect
JP ₁	1	Set the Input Reference (V_{REF}) to $0.5V_{DD}$
	2	Set the Input Reference (V_{REF}) to $0.1V_{DD}$
JP ₂	1	Drive Integrator with Comparator
	2	Ground Integrator's Resistor (constant input current)
	3	Drive Integrator with External Source
JP ₃ , JP ₄	1	Ground (de-activate) Integrator's Reset Switch (M_1)
	2	Drive Integrator's Reset Switch (M_1) with Comparator

Table 2-2 shows the integrator control strategies

TABLE 2-2: INTEGRATOR CONTROL STRATEGY

Integrator Control Strategy	Jumper Positions				Integrator's Input Voltage	R2 (Integrator)
	JP1	JP2	JP3	JP4		
Feedback Loop ⁽¹⁾	1	1	1	1	VCMP (internal)	open
	2	1	1	1		
Reset Switch ⁽²⁾	2	2	2	2	GND (internal)	open
Stand Alone	1	3	1	1	VINX	>> R1
	2	3	1	1		

- Note 1:** The circuit shown uses a non-inverting comparator to close the feedback loop.
2: The reset switch (MOSFET) in the circuit is controlled by a non-inverting comparator.

2.4 MCP6XXX AMPLIFIER EVALUATION BOARD 4 OPERATION

Items discussed in this section include:

- Building the Amplifier
- Testing the Amplifier
- Amplifier Modification: Using 8-Pin SOIC Op Amps

2.4.1 Building the Amplifier

This inverting integrator is described as follows:

- Power Supply V_{DD} is 5.0V
- Load Capacitance C_L is 56 pF
- Load Resistance R_L is 1.6 k Ω
- $R_1 = 8.06$ k Ω , R_2 is open, $R_3 = 8.06$ k Ω , $C_1 = 1$ μ F, $R_{ISO} = 0\Omega$
- Input Reference $V_{REF} = 0.5V_{DD}$
- Integrator Control Strategy: Feedback Loop (JP1: Position 1, JP2: Position 1, JP3: Position 1, JP4: Position 1)
- The fully assembled inverting integrator is shown in Figure 2-6.

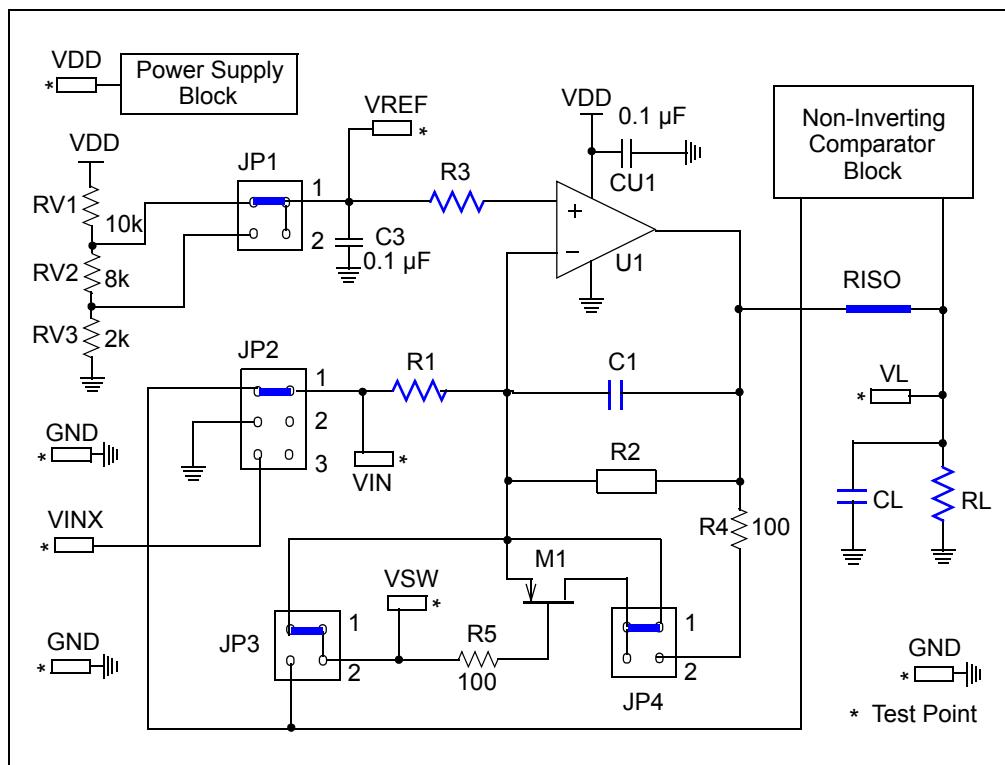

FIGURE 2-6: Inverting Integrator Example Supported by the MCP6XXX Amplifier Evaluation Board 4.

MCP6XXX Amplifier Evaluation Board 4 User's Guide

The fully assembled MCP6XXX Amplifier Evaluation Board 4 top view is shown in Figure 2-7 (without any user selected components).

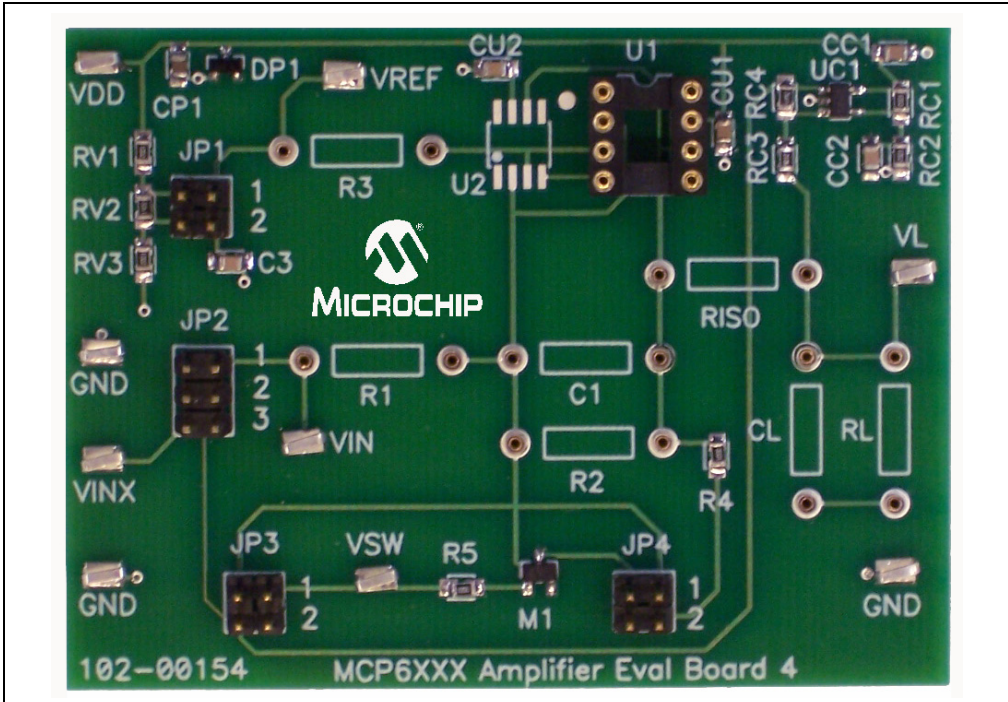

FIGURE 2-7: Picture of the Inverting Integrator Supported by the MCP6XXX Amplifier Evaluation Board 4.

2.4.2 Testing the Amplifier

2.4.2.1 CHECKING THE TEST POINTS

The (surface mount) test points for power supply, ground, input signal and output signal allow lab equipment to be connected to the board. Figure 2-8 shows the test points to check.

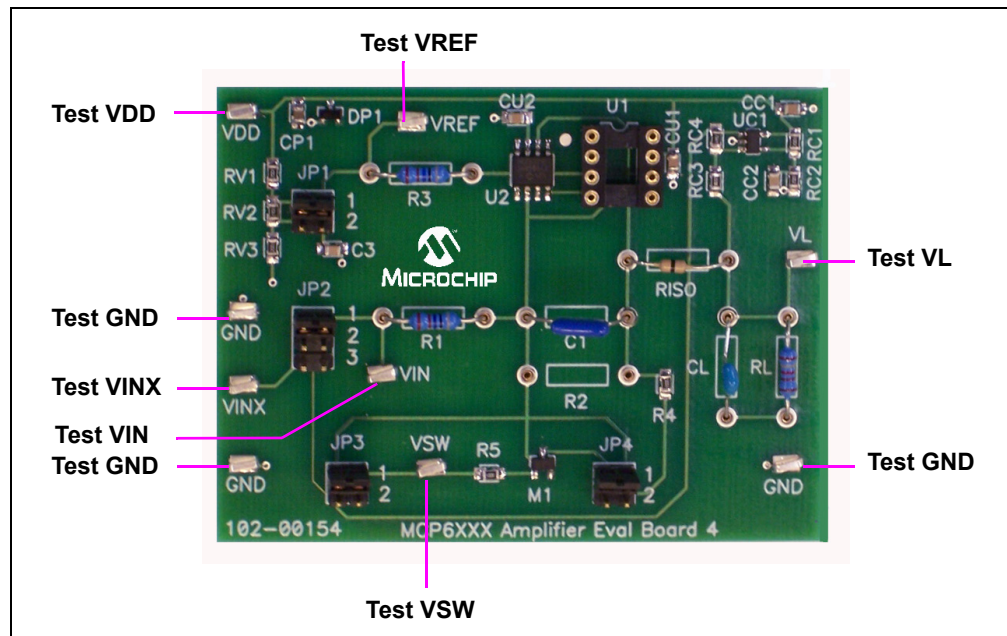

FIGURE 2-8: Checking the Test Points.

2.4.2.2 INVERTING INTEGRATOR RESPONSE

The MCP6021 op amp, 1% resistors, and 5% capacitors were used to build an inverting integrator circuit. The measured response with feedback control strategy is shown in Figure 2-9.

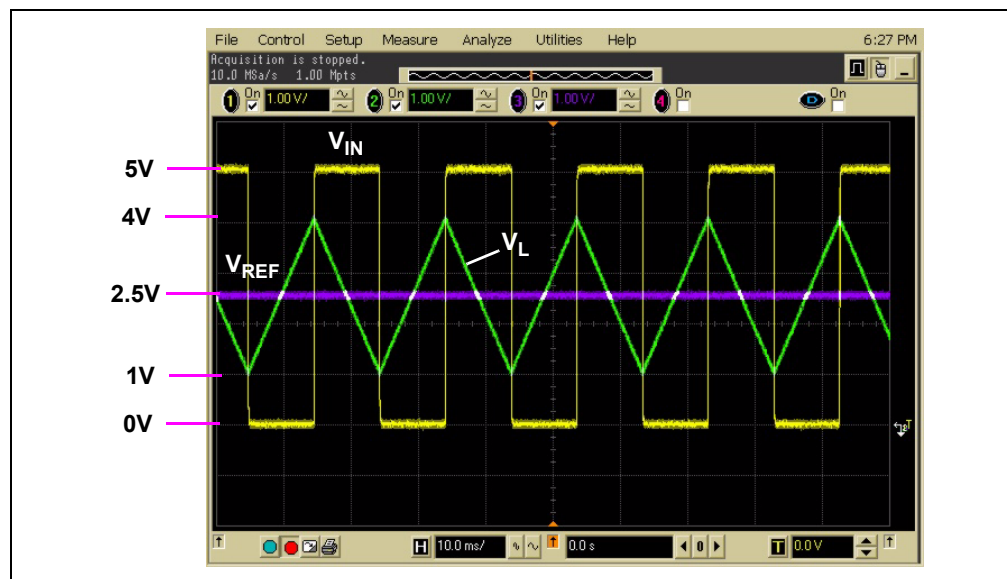

FIGURE 2-9: Measured Output Response.

MCP6XXX Amplifier Evaluation Board 4 User's Guide

2.4.3 Amplifier Modifications Using 8-Pin SOIC Op Amps

There are two options available when using single op amps in SOIC-8 packages (150 mil wide):

- Soldering onto the MCP6XXX Amplifier Evaluation Board 4, or
- Soldering it onto a separate board which is connected to the DIP-8 socket

Note: The DIP-8 socket must be empty; only one op amp can be used at a time.

Figure 2-10 shows a SOIC-8 op amp soldered onto the MCP6XXX Amplifier Evaluation Board 4.

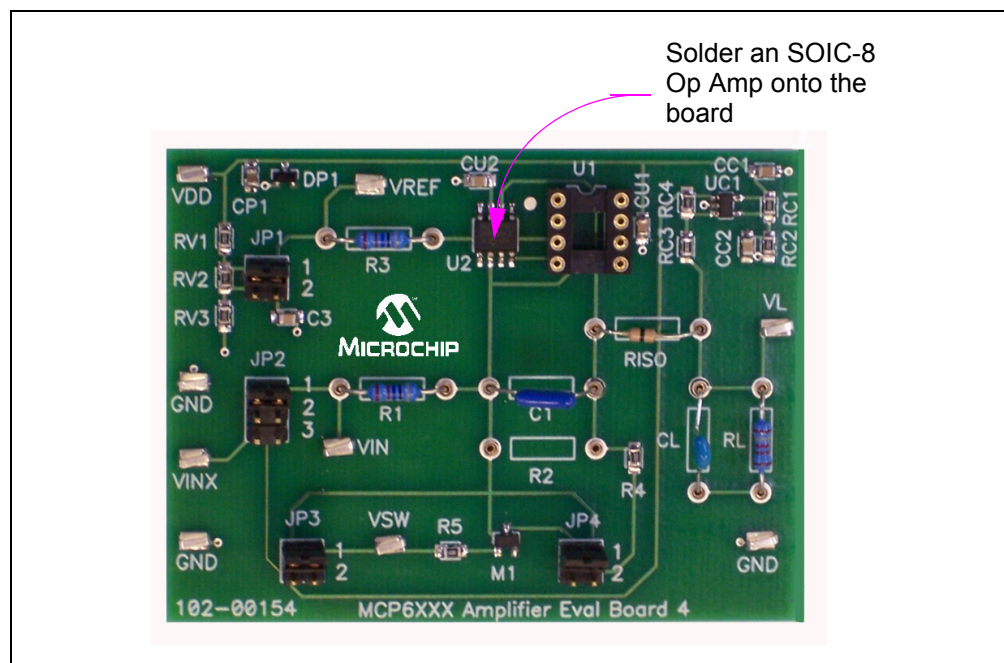

FIGURE 2-10: Op Amp in SOIC-8 package soldered onto MCP6XXX Amplifier Evaluation Board 4.

Figure 2-11 shows a SOIC-8 op amp and a DIP-8 socket, soldered onto the 8-Pin SOIC/MSOP/TSSOP/DIP Evaluation Board available from Microchip Technology Inc. (order # SOIC8EV). The two interconnect strips on the bottom are Samtec part # BBS-14-T-B or equivalent and are soldered into the through holes for the DIP-8 socket. Figure 2-12 shows this board plugged into the MCP6XXX Amplifier Evaluation Board 4.

Note: Insert the interconnect strips into the DIP-8 socket on the MCP6XXX Amplifier Evaluation Board 4. Place the SOIC8EV board on the top of the interconnect strips with the same pin orientation. Now solder the strips to the top board; this procedure ensures correct alignment of the strips. Clip the pins flush with the top surface of the SOIC8EV board, then solder the SOIC-8 op amp on the top.

Installation and Operation

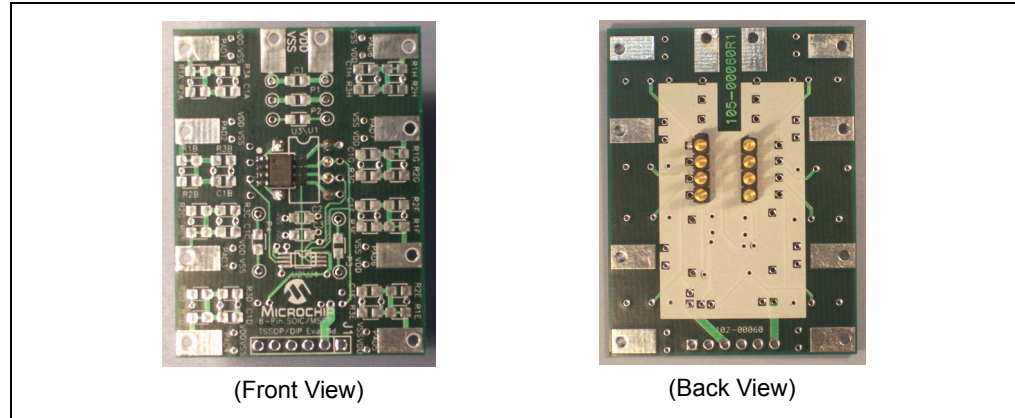

FIGURE 2-11: Op Amp in SOIC-8 package soldered to a separate board.

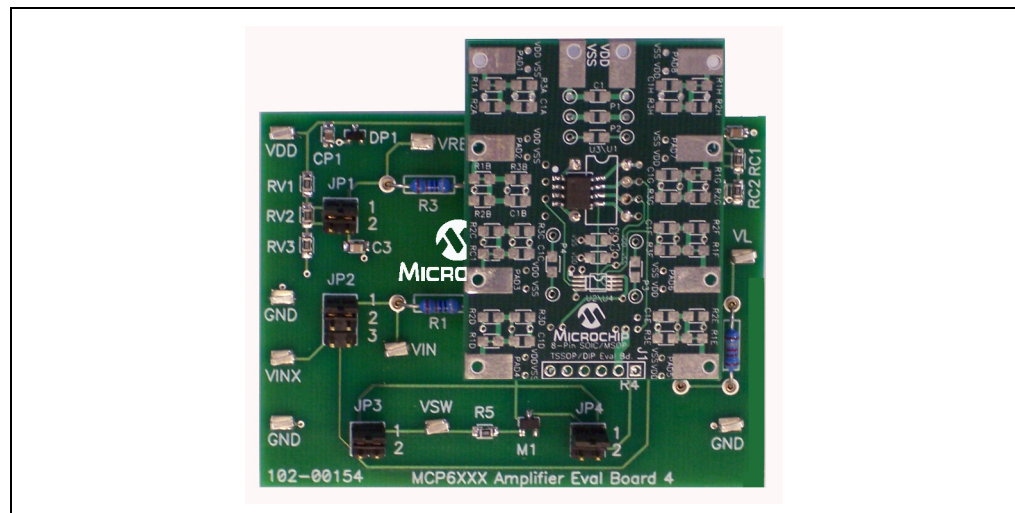

FIGURE 2-12: Connecting Adaptor Board onto MCP6XXX Amplifier Evaluation Board 4.

MCP6XXX Amplifier Evaluation Board 4 User's Guide

NOTES:



MCP6XXX AMPLIFIER EVALUATION BOARD 4 USER'S GUIDE

Appendix A. Schematic and Layouts

A.1 INTRODUCTION

This appendix contains the following schematics and layouts for the MCP6XXX Amplifier Evaluation Board 4:

- Board – Schematic
- Board – Top Silk and Metal Layers
- Board – Top Metal Layer
- Board – Bottom Metal Layer

MCP6XXX Amplifier Evaluation Board 4 User's Guide

A.2 BOARD - SCHEMATIC

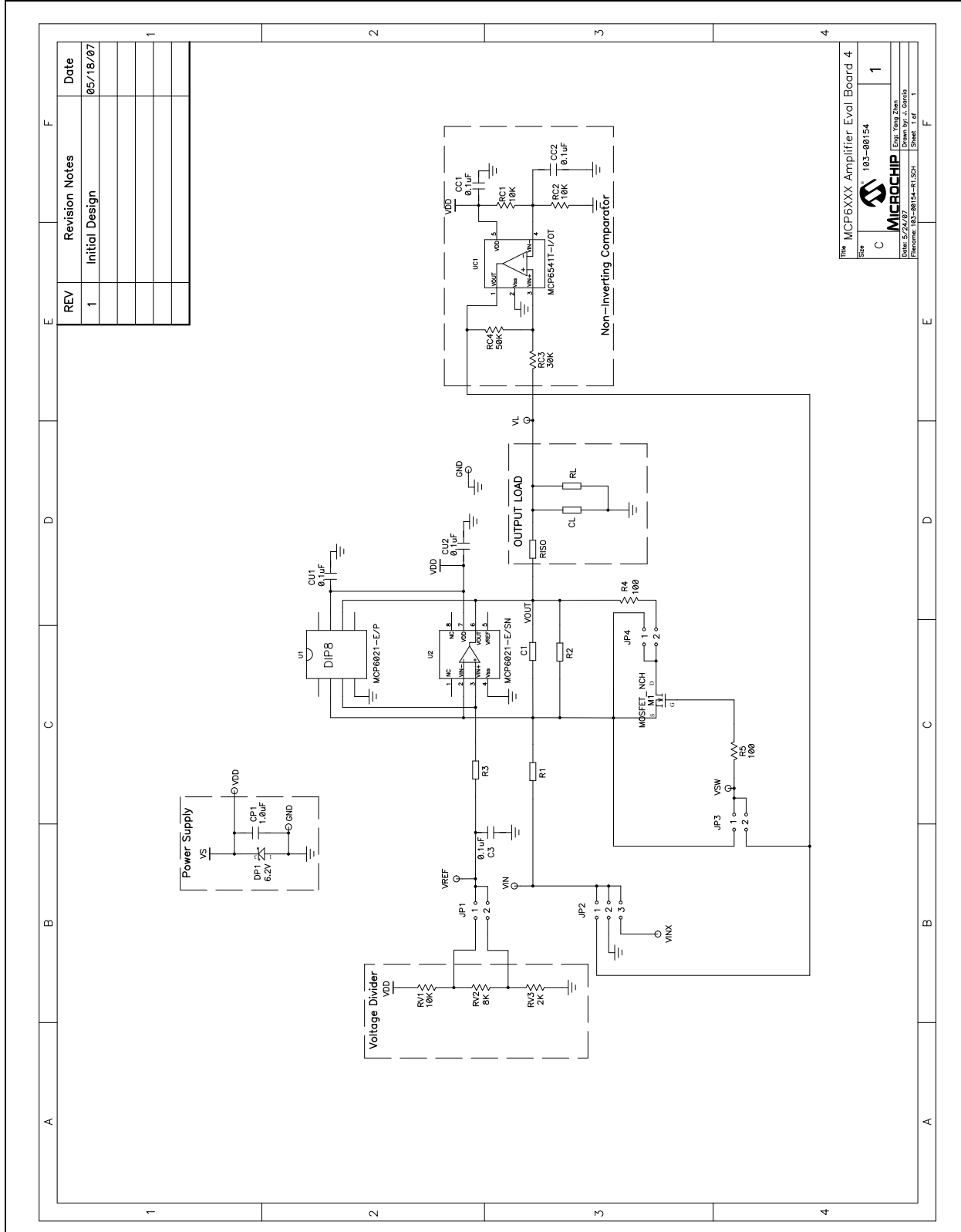

A.3 BOARD - TOP SILK AND METAL LAYERS

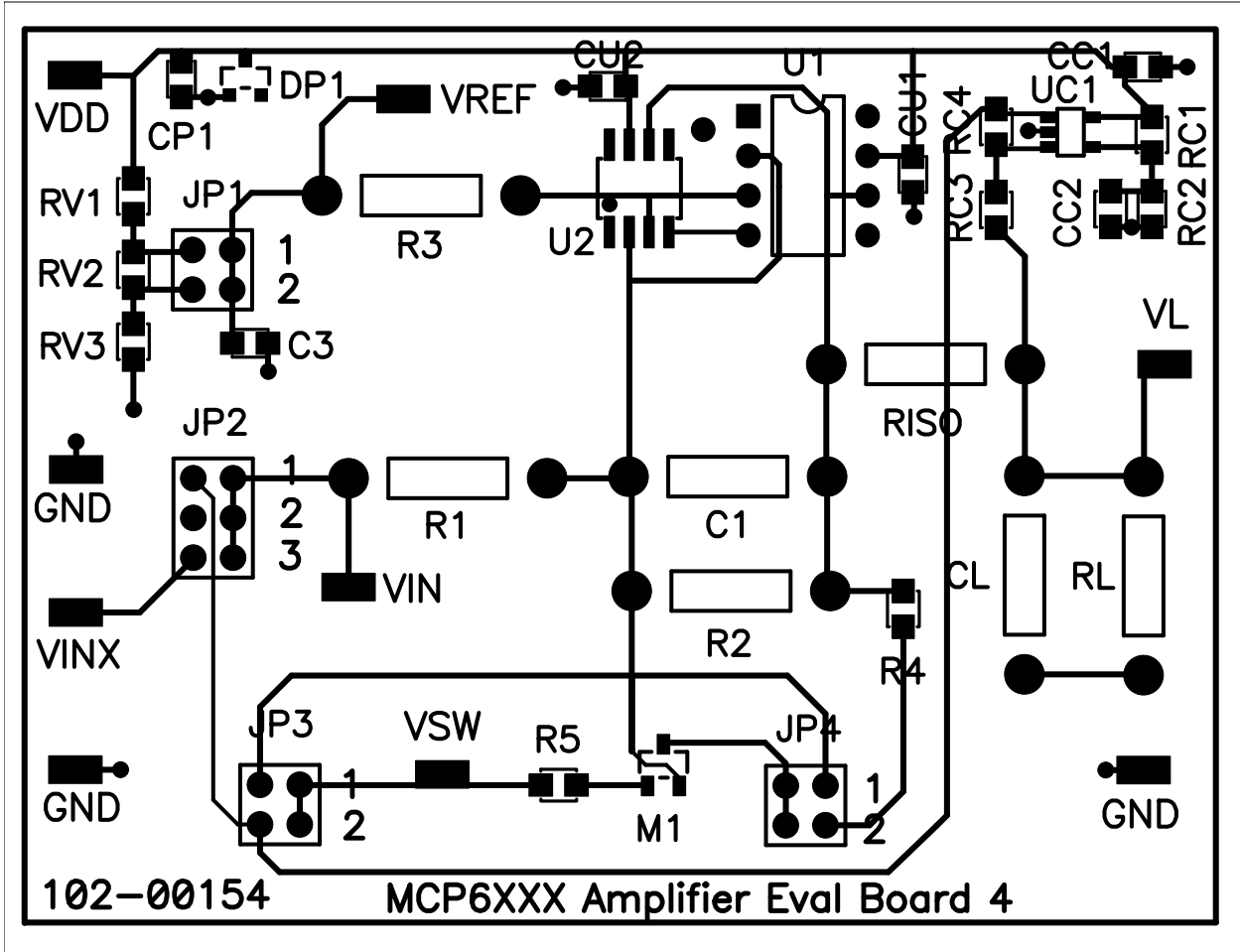

MCP6XXX Amplifier Evaluation Board 4 User's Guide

A.4 BOARD - TOP METAL LAYER

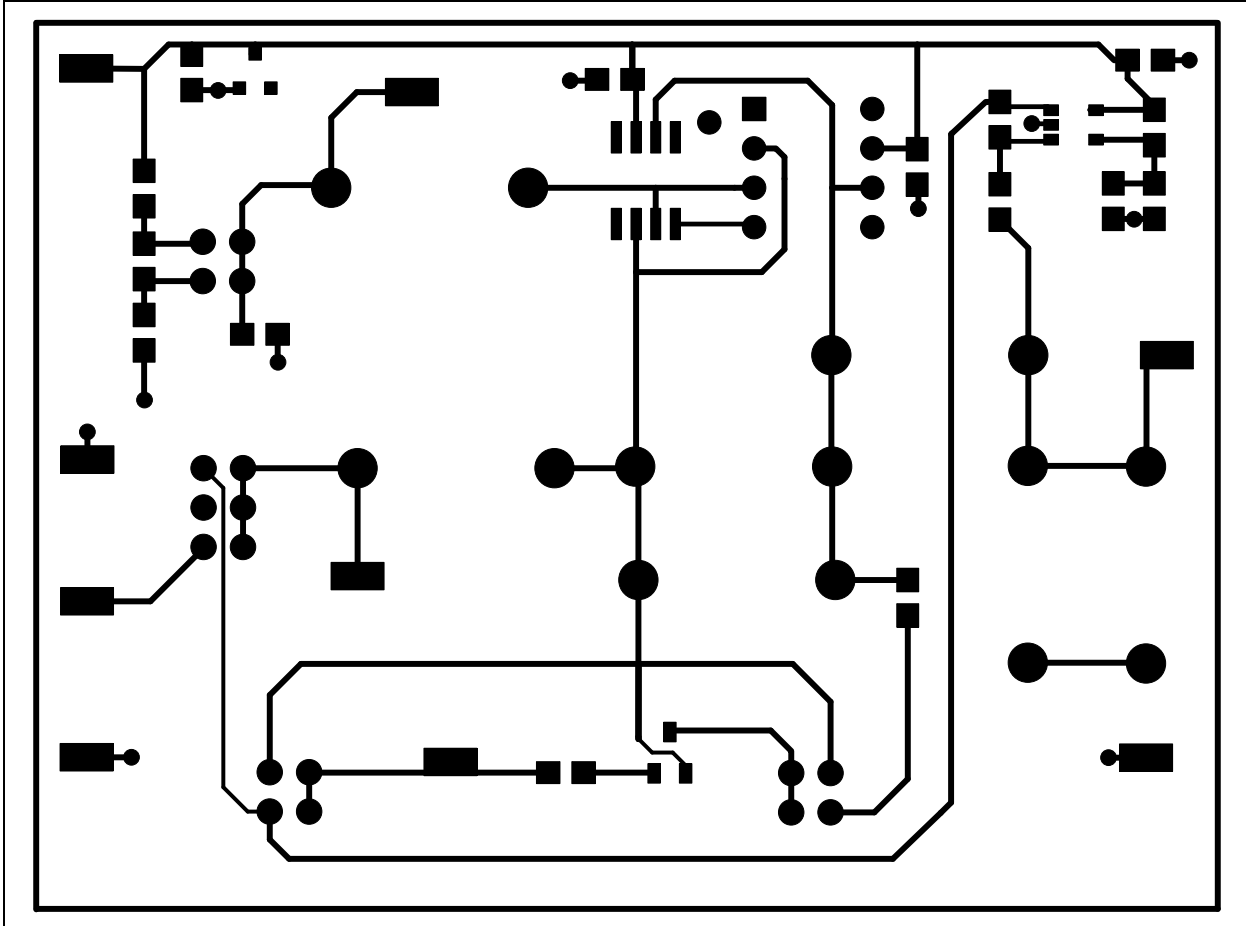

A.5 BOARD - BOTTOM METAL LAYER

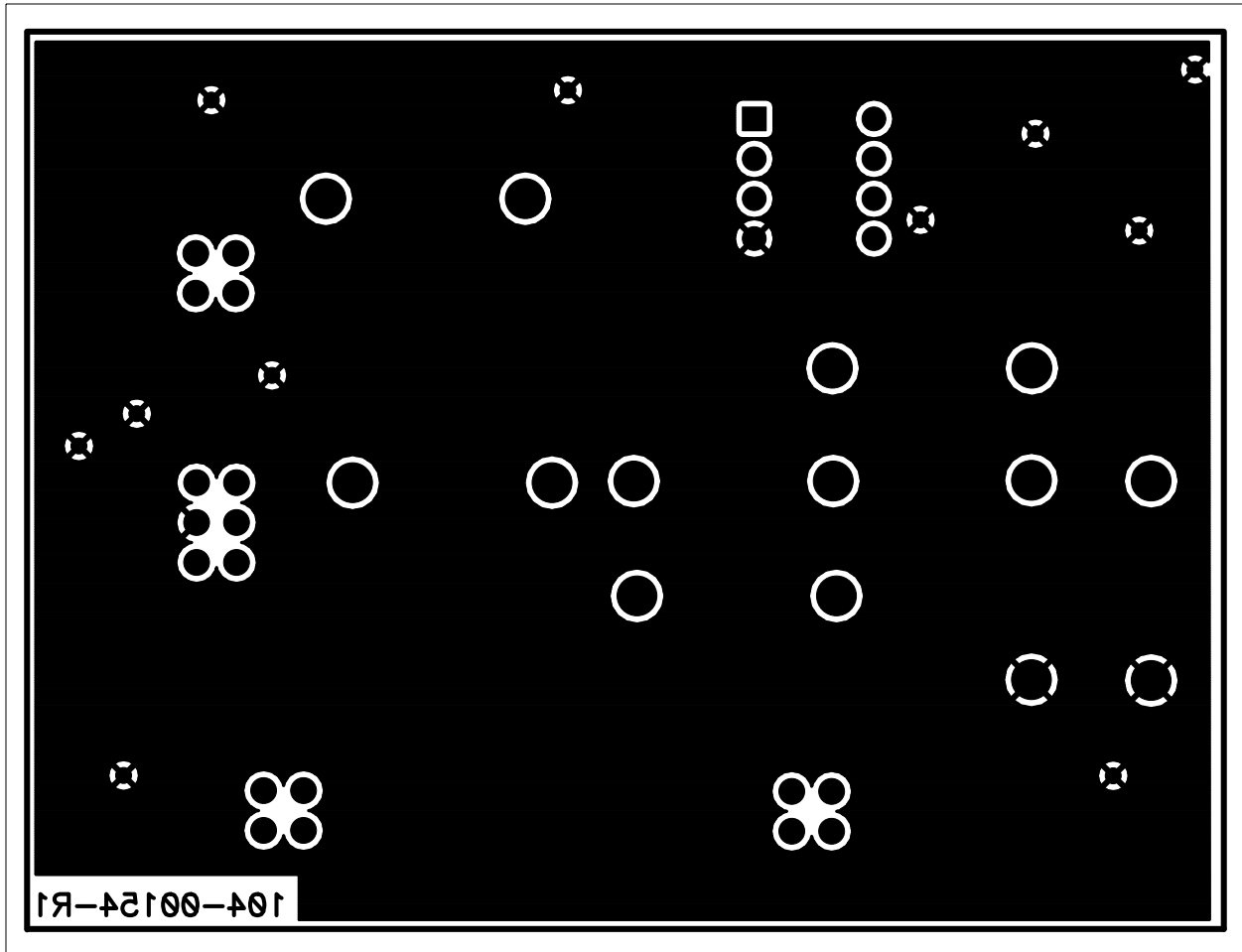

MCP6XXX Amplifier Evaluation Board 4 User's Guide

NOTES:

Appendix B. Bill of Materials (BOM)

B.1 MCP6XXX AMPLIFIER EVALUATION BOARD 4 BOM

The Bill of Materials (BOM) in Table B-1 corresponds to Figure 2-1 and Figure 2-2. Unpopulated parts are in Table B-2.

TABLE B-1: BILL OF MATERIALS (102-00154R1) (NOTE 1)

Qty	Reference	Description	Manufacturer	Part Number
1	CP1	CAP CERAMIC 1UF 10% 25V X5R 0805	Panasonic® - ECG	ECJ-2FB1E105K
5	CC1, CC2, C3, CU1, CU2	CAP CERAMIC .1UF 10% 25V X7R 0805	Panasonic - ECG	ECJ-2VB1E104K
1	DP1	DIODE ZENER 6.2V 350MW SOT-23	Fairchild Semiconductor®	BZX84C6V2
4	EA Corner	BUMPER CLEAR .375 x .15" DOME	Richco Plastic Co	RBS-12
2	JP1, JP3	CONN HEADR BRKWAY .100 04POS STR	Tyco® Electronics/Amp	9-146258-0-02
1	JP2	CONN HEADR BRKWAY .100 06POS STR	Tyco Electronics/Amp	4-103327-0-06
1	M1	MOSFET N-CH 30V 500MA SOT-346	Rohm	RJK005N03T146
1	PCB	RoHS Compliant Bare PCB, MCP6XXX Amplifier Eval Board #4	—	104-00154
14	Pin Socket	PIN RECPT .015/.025 DIA 0667 SER	Mill-Max®	0667-0-15-01-30-27-10-0
3	RC1, RC2, RV1	RES 10.0K OHM 1/8W 1% 0805 SMD	Panasonic - ECG	ERJ-6ENF1002V
1	RC3	RES 30.1K OHM 1/8W 1% 0805 SMD	Panasonic - ECG	ERJ-6ENF3012V
1	RC4	RES 49.9K OHM 1/8W 1% 0805 SMD	Panasonic - ECG	ERJ-6ENF4992V
1	RV2	RES 8.06K OHM 1/8W 1% 0805 SMD	Panasonic - ECG	ERJ-6ENF8061V
1	RV3	RES 2.0K OHM 1/8W 1% 0805 SMD	Panasonic - ECG	ERJ-6ENF2001V
2	R4,R5	RES 100 OHM 1/8W 1% 0805 SMD	Panasonic - ECG	ERJ-6ENF1000V
3	Shunt for JP1, JP2, JP3	SOCKET,SHORT BLKS W TAB BLK	Jameco Value-Pro	2012JH-R
9	Test Points	PC TEST POINT COMPACT SMT	Keystone Electronics®	5016
1	UC1	MCP6541 SOT-23-5 Single Op Amp	Microchip Technology Inc.	MCP6541T-I/OT
1	For U1	CONN IC SOCKET 8POS DIP TIN	Tyco Electronics/Amp	2-641260-1

Note 1: The components listed in this Bill of Materials are representative of the PCB assembly. The released BOM used in manufacturing uses all RoHS-compliant components.

MCP6XXX Amplifier Evaluation Board 4 User's Guide

TABLE B-2: BILL OF MATERIALS – UNPOPULATED PARTS (102-00154R1)

Qty	Reference	Description	Manufacturer	Part Number
1	U1	MCP6021 PDIP-8, Single Op Amp	Microchip Technology Inc	MCP6021-E/P
7	R1-R3, C1, RISO, RL, CL	Not Populated when shipped to customer	—	—

Note 1: The components listed in this Bill of Materials are representative of the PCB assembly. The released BOM used in manufacturing uses all RoHS-compliant components.

The BOM in Table B-3 corresponds to the collection of resistors, capacitors, jumpers and MCP6021 op amps that come in the Accessory Bag which is shipped in the MCP6XXX Amplifier Evaluation Board 4 Kit. These components are placed in an separate ESD bag. They support the circuit in **Section 2.4.1 “Building the Amplifier”**. Customers need to provide the resistors and capacitors for more amplifier circuits.

TABLE B-3: BILL OF MATERIALS – ACCESSORY BAG PARTS (102-00148R1)

Qty	Reference	Description	Manufacturer	Part Number
1	Accessory Bag	CAP CER 56PF 50V C0G RADIAL	Murata Electronics®	RPE5C1H560J2P1Z03B
1	Accessory Bag	CAP CER 1UF 25V X7R RAD	TDK® Corporation	FK24X7R1E105K
1	Accessory Bag	JUMPER ZERO OHM 1/8W	Yageo® Corporation	ZOR-12-B-52
2	Accessory Bag	RES 8.06K OHM 1/4W 1% METAL FILM	Yageo Corporation	MFR-25FBF-8K06
1	Accessory Bag	RES 1.58K OHM 1/4W 1% METAL FILM	Yageo Corporation	MFR-25FBF-1K58

Note 1: The components listed in this Bill of Materials are representative of the PCB assembly. The released BOM used in manufacturing uses all RoHS-compliant components.

NOTES:



WORLDWIDE SALES AND SERVICE

AMERICAS

Corporate Office
2355 West Chandler Blvd.
Chandler, AZ 85224-6199
Tel: 480-792-7200
Fax: 480-792-7277
Technical Support:
<http://support.microchip.com>
Web Address:
www.microchip.com

Atlanta

Duluth, GA
Tel: 678-957-9614
Fax: 678-957-1455

Boston

Westborough, MA
Tel: 774-760-0087
Fax: 774-760-0088

Chicago

Itasca, IL
Tel: 630-285-0071
Fax: 630-285-0075

Dallas

Addison, TX
Tel: 972-818-7423
Fax: 972-818-2924

Detroit

Farmington Hills, MI
Tel: 248-538-2250
Fax: 248-538-2260

Kokomo

Kokomo, IN
Tel: 765-864-8360
Fax: 765-864-8387

Los Angeles

Mission Viejo, CA
Tel: 949-462-9523
Fax: 949-462-9608

Santa Clara

Santa Clara, CA
Tel: 408-961-6444
Fax: 408-961-6445

Toronto

Mississauga, Ontario,
Canada
Tel: 905-673-0699
Fax: 905-673-6509

ASIA/PACIFIC

Asia Pacific Office
Suites 3707-14, 37th Floor
Tower 6, The Gateway
Harbour City, Kowloon
Hong Kong
Tel: 852-2401-1200
Fax: 852-2401-3431

Australia - Sydney
Tel: 61-2-9868-6733
Fax: 61-2-9868-6755

China - Beijing
Tel: 86-10-8528-2100
Fax: 86-10-8528-2104

China - Chengdu
Tel: 86-28-8665-5511
Fax: 86-28-8665-7889

China - Fuzhou
Tel: 86-591-8750-3506
Fax: 86-591-8750-3521

China - Hong Kong SAR
Tel: 852-2401-1200
Fax: 852-2401-3431

China - Qingdao
Tel: 86-532-8502-7355
Fax: 86-532-8502-7205

China - Shanghai
Tel: 86-21-5407-5533
Fax: 86-21-5407-5066

China - Shenyang
Tel: 86-24-2334-2829
Fax: 86-24-2334-2393

China - Shenzhen
Tel: 86-755-8203-2660
Fax: 86-755-8203-1760

China - Shunde
Tel: 86-757-2839-5507
Fax: 86-757-2839-5571

China - Wuhan
Tel: 86-27-5980-5300
Fax: 86-27-5980-5118

China - Xian
Tel: 86-29-8833-7252
Fax: 86-29-8833-7256

ASIA/PACIFIC

India - Bangalore
Tel: 91-80-4182-8400
Fax: 91-80-4182-8422

India - New Delhi
Tel: 91-11-4160-8631
Fax: 91-11-4160-8632

India - Pune
Tel: 91-20-2566-1512
Fax: 91-20-2566-1513

Japan - Yokohama
Tel: 81-45-471- 6166
Fax: 81-45-471-6122

Korea - Daegu
Tel: 82-53-744-4301
Fax: 82-53-744-4302

Korea - Seoul
Tel: 82-2-554-7200
Fax: 82-2-558-5932 or
82-2-558-5934

Malaysia - Penang
Tel: 60-4-646-8870
Fax: 60-4-646-5086

Philippines - Manila
Tel: 63-2-634-9065
Fax: 63-2-634-9069

Singapore
Tel: 65-6334-8870
Fax: 65-6334-8850

Taiwan - Hsin Chu
Tel: 886-3-572-9526
Fax: 886-3-572-6459

Taiwan - Kaohsiung
Tel: 886-7-536-4818
Fax: 886-7-536-4803

Taiwan - Taipei
Tel: 886-2-2500-6610
Fax: 886-2-2508-0102

Thailand - Bangkok
Tel: 66-2-694-1351
Fax: 66-2-694-1350

EUROPE

Austria - Wels
Tel: 43-7242-2244-39
Fax: 43-7242-2244-393

Denmark - Copenhagen
Tel: 45-4450-2828
Fax: 45-4485-2829

France - Paris
Tel: 33-1-69-53-63-20
Fax: 33-1-69-30-90-79

Germany - Munich
Tel: 49-89-627-144-0
Fax: 49-89-627-144-44

Italy - Milan
Tel: 39-0331-742611
Fax: 39-0331-466781

Netherlands - Drunen
Tel: 31-416-690399
Fax: 31-416-690340

Spain - Madrid
Tel: 34-91-708-08-90
Fax: 34-91-708-08-91

UK - Wokingham
Tel: 44-118-921-5869
Fax: 44-118-921-5820

06/25/07



Стандарт Электрон Связь

Мы молодая и активно развивающаяся компания в области поставок электронных компонентов. Мы поставляем электронные компоненты отечественного и импортного производства напрямую от производителей и с крупнейших складов мира.

Благодаря сотрудничеству с мировыми поставщиками мы осуществляем комплексные и плановые поставки широчайшего спектра электронных компонентов.

Собственная эффективная логистика и склад в обеспечивает надежную поставку продукции в точно указанные сроки по всей России.

Мы осуществляем техническую поддержку нашим клиентам и предпродажную проверку качества продукции. На все поставляемые продукты мы предоставляем гарантию .

Осуществляем поставки продукции под контролем ВП МО РФ на предприятия военно-промышленного комплекса России , а также работаем в рамках 275 ФЗ с открытием отдельных счетов в уполномоченном банке. Система менеджмента качества компании соответствует требованиям ГОСТ ISO 9001.

Минимальные сроки поставки, гибкие цены, неограниченный ассортимент и индивидуальный подход к клиентам являются основой для выстраивания долгосрочного и эффективного сотрудничества с предприятиями радиоэлектронной промышленности, предприятиями ВПК и научно-исследовательскими институтами России.

С нами вы становитесь еще успешнее!

Наши контакты:

Телефон: +7 812 627 14 35

Электронная почта: sales@st-electron.ru

Адрес: 198099, Санкт-Петербург,
Промышленная ул, дом № 19, литера Н,
помещение 100-Н Офис 331