

## FEATURES

- **Accurate Linear Gain Control:**  $\pm 1\%$  Typ,  $\pm 3\%$  Max
- **Constant Gain with Temperature**
- **Wide Bandwidth:** 40MHz
- **High Slew Rate:** 300V/ $\mu$ s
- **Fast Control Path:** 10MHz
- **Low Control Feedthrough:** 2.5mV
- **High Output Current:** 40mA
- **Low Output Noise**  
 $45\text{nV}/\sqrt{\text{Hz}}$  at  $A_V = 1$   
 $270\text{nV}/\sqrt{\text{Hz}}$  at  $A_V = 100$
- **Low Distortion:** 0.01%
- **Wide Supply Range:**  $\pm 2.5\text{V}$  to  $\pm 15\text{V}$
- **Low Supply Current:** 13mA
- **Low Differential Gain and Phase:** 0.02%, 0.02°

## APPLICATIONS

- Composite Video Gain Control
- RGB, YUV Video Gain Control
- Video Faders, Keysers
- Gamma Correction Amplifiers
- Audio Gain Control, Faders
- Multipliers, Modulators
- Electronically Tunable Filters

LT, LTC and LT are registered trademarks of Linear Technology Corporation.

## DESCRIPTION

The LT<sup>®</sup>1251/LT1256 are 2-input, 1-output, 40MHz current feedback amplifiers with a linear control circuit that sets the amount each input contributes to the output. These parts make excellent electronically controlled variable gain amplifiers, filters, mixers and faders. The only external components required are the power supply bypass capacitors and the feedback resistors. Both parts operate on supplies from  $\pm 2.5\text{V}$  (or single 5V) to  $\pm 15\text{V}$  (or single 30V).

Absolute gain accuracy is trimmed at wafer sort to minimize part-to-part variations. The circuit is completely temperature compensated.

The LT1251 includes circuitry that eliminates the need for accurate control signals around zero and full scale. For control signals of less than 2% or greater than 98%, the LT1251 sets one input completely off and the other completely on. This is ideal for fader applications because it eliminates off-channel feedthrough due to offset or gain errors in the control signals.

The LT1256 does not have this on/off feature and operates linearly over the complete control range. The LT1256 is recommended for applications requiring more than 20dB of linear control range.

## TYPICAL APPLICATION

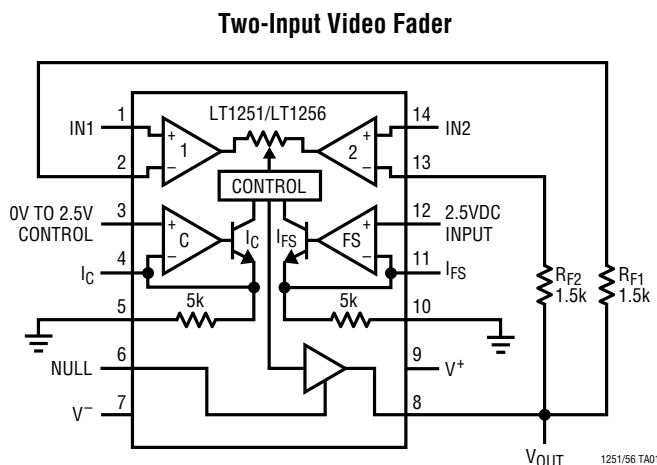

**LT1256**  
**Gain Accuracy vs Control Voltage**

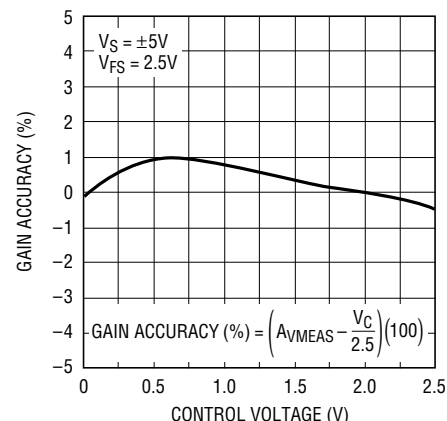

## ABSOLUTE MAXIMUM RATINGS

Total Supply Voltage ( $V^+$ to $V^-$ ) .....	36V
Input Current .....	$\pm 15\text{mA}$
Input Voltage on Pins 3,4,5,10,11,12 .....	$V^-$ to $V^+$
Output Short-Circuit Duration (Note 1) .....	Continuous
Specified Temperature Range (Note 2) .....	$0^\circ\text{C}$ to $70^\circ\text{C}$
Operating Temperature Range .....	$-40^\circ\text{C}$ to $85^\circ\text{C}$
Storage Temperature Range .....	$-65^\circ\text{C}$ to $150^\circ\text{C}$
Junction Temperature (Note 3) .....	$150^\circ\text{C}$
Lead Temperature (Soldering, 10 sec) .....	$300^\circ\text{C}$

## PACKAGE/ORDER INFORMATION

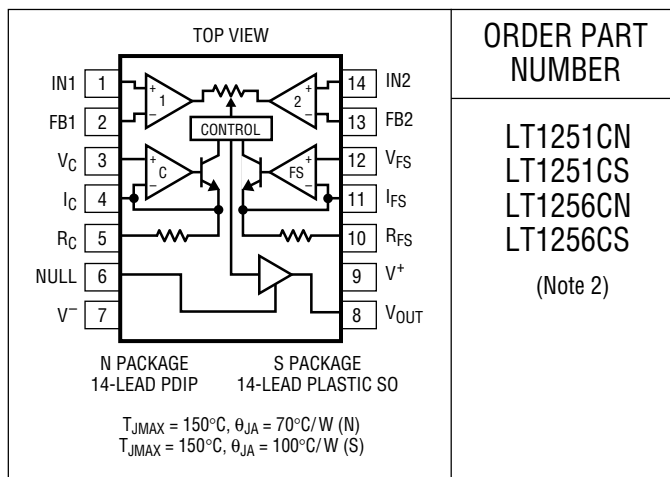

ORDER PART NUMBER

LT1251CN  
 LT1251CS  
 LT1256CN  
 LT1256CS

(Note 2)

Consult factory for Industrial and Military grade parts.

## SIGNAL AMPLIFIER AC CHARACTERISTICS

$0^\circ\text{C} \leq T_A \leq 70^\circ\text{C}$ ,  $V_S = \pm 5\text{V}$ ,  $V_{IN} = 1V_{RMS}$ ,  $f = 1\text{kHz}$ ,  $A_{VMAX} = 1$ ,  $R_{F1} = R_{F2} = 1.5\text{k}$ ,  $V_{FS} = 2.5\text{V}$ ,  $I_C = I_{FS} = \text{NULL} = \text{Open}$ , Pins 5, 10 = GND, unless otherwise noted.

SYMBOL	PARAMETER	CONDITIONS	MIN	TYP	MAX	UNITS	
2%IN1	2% Input 1 Gain	$V_C$ (Pin 3) = 0.05V	LT1251	●	0	0.1	%
			LT1256	●	0.1	5.0	%
10%IN1	10% Input 1 Gain	$V_C$ (Pin 3) = 0.25V		●	7	13	%
20%IN1	20% Input 1 Gain	$V_C$ (Pin 3) = 0.50V		●	17	23	%
30%IN1	30% Input 1 Gain	$V_C$ (Pin 3) = 0.75V		●	27	33	%
40%IN1	40% Input 1 Gain	$V_C$ (Pin 3) = 1.00V		●	37	43	%
50%IN1	50% Input 1 Gain	$V_C$ (Pin 3) = 1.25V		●	47	53	%
60%IN1	60% Input 1 Gain	$V_C$ (Pin 3) = 1.50V		●	57	63	%
70%IN1	70% Input 1 Gain	$V_C$ (Pin 3) = 1.75V		●	67	73	%
80%IN1	80% Input 1 Gain	$V_C$ (Pin 3) = 2.00V		●	77	83	%
90%IN1	90% Input 1 Gain	$V_C$ (Pin 3) = 2.25V		●	87	93	%
98%IN1	98% Input 1 Gain	$V_C$ (Pin 3) = 2.45V	LT1251	●	99.9	100.0	%
			LT1256	●	95.0	99.9	%
2%IN2	2% Input 2 Gain	$V_C$ (Pin 3) = 2.45V	LT1251	●	0	0.1	%
			LT1256	●	0.1	5.0	%
10%IN2	10% Input 2 Gain	$V_C$ (Pin 3) = 2.25V		●	7	13	%
20%IN2	20% Input 2 Gain	$V_C$ (Pin 3) = 2.00V		●	17	23	%
30%IN2	30% Input 2 Gain	$V_C$ (Pin 3) = 1.75V		●	27	33	%
40%IN2	40% Input 2 Gain	$V_C$ (Pin 3) = 1.50V		●	37	43	%
50%IN2	50% Input 2 Gain	$V_C$ (Pin 3) = 1.25V		●	47	53	%
60%IN2	60% Input 2 Gain	$V_C$ (Pin 3) = 1.00V		●	57	63	%
70%IN2	70% Input 2 Gain	$V_C$ (Pin 3) = 0.75V		●	67	73	%
80%IN2	80% Input 2 Gain	$V_C$ (Pin 3) = 0.50V		●	77	83	%
90%IN2	90% Input 2 Gain	$V_C$ (Pin 3) = 0.25V		●	87	93	%
98%IN2	98% Input 2 Gain	$V_C$ (Pin 3) = 0.05V	LT1251	●	99.9	100.0	%
			LT1256	●	95.0	99.9	%
	Gain Drift with Temperature (Worst Case at 30% Gain)	$V_C$ (Pin 3) = 0.75V	N Package		50		ppm/ $^\circ\text{C}$
$V_C$ (Pin 3) = 0.75V		S Package		400		ppm/ $^\circ\text{C}$	

## SIGNAL AMPLIFIER AC CHARACTERISTICS

0°C ≤ T<sub>A</sub> ≤ 70°C, V<sub>S</sub> = ±5V, V<sub>IN</sub> = 1V<sub>RMS</sub>, f = 1kHz, A<sub>VMAX</sub> = 1, R<sub>F1</sub> = R<sub>F2</sub> = 1.5k, V<sub>FS</sub> = 2.5V, I<sub>C</sub> = I<sub>FS</sub> = NULL = Open, Pins 5,10 = GND, unless otherwise noted.

SYMBOL	PARAMETER	CONDITIONS	MIN	TYP	MAX	UNITS
	Gain Supply Rejection	V <sub>C</sub> = 1.25V, V <sub>S</sub> = ±5V to ±15V	●	0.03	0.10	%/V
	External Resistor Gain 50% Input 1	Pins 5,10 = Open, External 5k Resistors from Pins 4,11 to Ground, V <sub>C</sub> = 1.25V	●	45	55	%
SR	Slew Rate	V <sub>IN</sub> = ±2.5V, V <sub>O</sub> at ±2V, R <sub>L</sub> = 150Ω	●	150	300	V/μs
	Control Feedthrough	V <sub>C</sub> = 1.25VDC + 2.5V <sub>P-P</sub> at 1kHz		2.5		mV <sub>P-P</sub>
	Full Power Bandwidth	V <sub>O</sub> = 1V <sub>RMS</sub>		20		MHz
BW	Small-Signal Bandwidth	V <sub>S</sub> = ±5V V <sub>S</sub> = ±15V		30 40		MHz MHz
	Differential Gain (Notes 4,5)	Control = 0% or 100% Control = 25% or 75%		0.02 0.90		% %
	Differential Phase (Notes 4,5)	Control = 0% or 100% Control = 25% or 75%		0.02 0.55		DEG DEG
THD	Total Harmonic Distortion	Gain = 100% Gain = 50% Gain = 10%		0.002 0.015 0.4		% % %
t <sub>r</sub> , t <sub>f</sub>	Rise Time, Fall Time	10% to 90%, V <sub>O</sub> = 100mV		11		ns
OS	Overshoot	V <sub>O</sub> = 100mV		3		%
t <sub>PD</sub>	Propagation Delay	V <sub>O</sub> = 100mV		10		ns
t <sub>S</sub>	Settling Time	0.1%, ΔV <sub>O</sub> = 2V		65		ns

## SIGNAL AMPLIFIER DC CHARACTERISTICS

0°C ≤ T<sub>A</sub> ≤ 70°C, V<sub>S</sub> = ±5V, V<sub>CM</sub> = 0V, V<sub>FS</sub> = 2.5V, I<sub>C</sub> = I<sub>FS</sub> = NULL = Open, Pins 5,10 = GND, unless otherwise noted.

SYMBOL	PARAMETER	CONDITIONS	MIN	TYP	MAX	UNITS	
V <sub>OS</sub>	Input Offset Voltage	Either Input Difference Between Inputs	● ●	2 1	5 3	mV mV	
	Input Offset Voltage Drift			10		μV/°C	
I <sub>IN</sub> <sup>+</sup>	Noninverting Input Bias Current	Either Input	●	-2.5	0.5	2.5	μA
I <sub>IN</sub> <sup>-</sup>	Inverting Input Bias Current	Either Input Difference Between Inputs	● ●	-30 -1	10 0.5	30 1	μA μA
	Inverting Input Bias Current Null Change	Null (Pin 6) Open to V <sup>-</sup>	●	-280	-170	-60	μA
e <sub>n</sub>	Input Noise Voltage Density	f = 1kHz		2.7		nV/√Hz	
+i <sub>n</sub>	Noninverting Input Noise Current Density	f = 1kHz		1.5		pA/√Hz	
-i <sub>n</sub>	Inverting Input Noise Current Density	f = 1kHz		29		pA/√Hz	
R <sub>IN</sub>	Input Resistance	Either Noninverting Input	●	5	17	MΩ	
C <sub>IN</sub>	Input Capacitance	Either Noninverting Input	●	1.5		pF	
	Input Voltage Range	V <sub>S</sub> = ±5V V <sub>S</sub> = 5V	● ● ●	±3 2	±3.2 3	V V	
CMRR	Common Mode Rejection Ratio	V <sub>CM</sub> = -3V to 3V V <sub>S</sub> = 5V, V <sub>CM</sub> = 2V to 3V, V <sub>O</sub> = 2.5V	● ●	55 50	61 57	dB dB	
	Inverting Input Current Common Mode Rejection	V <sub>CM</sub> = -3V to 3V V <sub>S</sub> = 5V, V <sub>CM</sub> = 2V to 3V, V <sub>O</sub> = 2.5V	● ●	0.07 0.17	0.25 0.70	μA/V μA/V	
PSRR	Power Supply Rejection Ratio	V <sub>S</sub> = ±5V to ±15V	●	70	76	dB	
	Noninverting Input Current Power Supply Rejection	V <sub>S</sub> = ±5V to ±15V	●	30	100	nA/V	
	Inverting Input Current Power Supply Rejection	V <sub>S</sub> = ±5V to ±15V	●	30	200	nA/V	

## SIGNAL AMPLIFIER DC CHARACTERISTICS

0°C ≤ T<sub>A</sub> ≤ 70°C, V<sub>S</sub> = ±5V, V<sub>CM</sub> = 0V, V<sub>FS</sub> = 2.5V, I<sub>C</sub> = I<sub>FS</sub> = NULL = Open, Pins 5,10 = GND, unless otherwise noted.

SYMBOL	PARAMETER	CONDITIONS	MIN	TYP	MAX	UNITS	
A <sub>VOL</sub>	Large-Signal Voltage Gain	V <sub>O</sub> = -3V to 3V, R <sub>L</sub> = 150Ω		83	93	dB	
		V <sub>O</sub> = -2.75V to 2.75V, R <sub>L</sub> = 150Ω	●	83		dB	
R <sub>OL</sub>	Transresistance, ΔV <sub>OUT</sub> /ΔI <sub>IN</sub> <sup>-</sup>	V <sub>O</sub> = -3V to 3V, R <sub>L</sub> = 150Ω		0.75	1.8	MΩ	
		V <sub>O</sub> = -2.75V to 2.75V, R <sub>L</sub> = 150Ω	●	0.75		MΩ	
V <sub>OUT</sub>	Maximum Output Voltage Swing	No Load	●	±4.0	±4.2	V	
		R <sub>L</sub> = 150Ω	●	±3.0	±3.5	V	
			●	±2.75		V	
		V <sub>S</sub> = ±15V, No Load	●	±14.0	±14.2	V	
		V <sub>S</sub> = 5V, V <sub>CM</sub> = 2.5V, (Note 6)	●	1.2		3.8	V
I <sub>O</sub>	Maximum Output Current	V <sub>S</sub> = ±5V	●	±30	±40	mA	
		V <sub>S</sub> = 5V, V <sub>CM</sub> = V <sub>O</sub> = 2.5V	●	±20	±30	mA	
I <sub>S</sub>	Supply Current	V <sub>C</sub> = V <sub>FS</sub> = 2.5V	●		13.5	17.0	mA
		V <sub>C</sub> = V <sub>FS</sub> = 1.25V	●		7.5	9.5	mA
		V <sub>C</sub> = V <sub>FS</sub> = 0V	●		1.3	1.8	mA
		V <sub>C</sub> = V <sub>FS</sub> = 2.5V, V <sub>S</sub> = ±15V	●		14.5	18.5	mA
		V <sub>C</sub> = V <sub>FS</sub> = 0V, V <sub>S</sub> = ±15V	●		1.4	2.0	mA

## CONTROL AND FULL SCALE AMPLIFIER CHARACTERISTICS

0°C ≤ T<sub>A</sub> ≤ 70°C, V<sub>S</sub> = ±5V, V<sub>FS</sub> = 2.5V, I<sub>C</sub> = I<sub>FS</sub> = NULL = Open, Pins 5,10 = GND, unless otherwise noted.

SYMBOL	PARAMETER	CONDITIONS	MIN	TYP	MAX	UNITS	
	Control Amplifier Input Offset Voltage	Pin 4 to Pin 3	●	5	15	mV	
	Full-Scale Amplifier Input Offset Voltage	Pin 11 to Pin 12	●	5	15	mV	
	Control Amplifier Input Resistance		●	25	100	MΩ	
	Full-Scale Amplifier Input Resistance		●	25	100	MΩ	
	Control Amplifier Input Bias Current		●	-750	-300	nA	
	Full-Scale Amplifier Input Bias Current		●	-750	-300	nA	
R <sub>C</sub>	Internal Control Resistor	T <sub>A</sub> = 25°C		3.75	5	6.25	kΩ
R <sub>FS</sub>	Internal Full-Scale Resistor	T <sub>A</sub> = 25°C		4	5	6	kΩ
	Resistor Temperature Coefficient				0.2		%/°C
	Control Path Bandwidth	Small Signal, V <sub>C</sub> = 100mV, (Note 7)		10		MHz	
	Control Path Rise and Fall Time	Small Signal, V <sub>C</sub> = 100mV, (Note 7)		35		ns	
	Control Path Transition Time	0% to 100%		150		ns	
	Control Path Propagation Delay	Small Signal, ΔV <sub>C</sub> = 100mV		50		ns	
		V <sub>C</sub> from 0% or 100%		90		ns	

The ● denotes specifications which apply over the specified operating temperature range.

**Note 1:** A heat sink may be required depending on the power supply voltage.

**Note 2:** Commercial grade parts are designed to operate over the temperature range of -40°C to 85°C but are neither tested nor guaranteed beyond 0°C to 70°C. Industrial grade parts specified and tested over -40°C to 85°C are available on special request. Consult factory.

**Note 3:** T<sub>J</sub> is calculated from the ambient temperature T<sub>A</sub> and the power dissipation P<sub>D</sub> according to the following formulas:

$$\begin{aligned} \text{LT1251CN/LT1256CN: } T_J &= T_A + (P_D \cdot 70^\circ\text{C/W}) \\ \text{LT1251CS/LT1256CS: } T_J &= T_A + (P_D \cdot 100^\circ\text{C/W}) \end{aligned}$$

**Note 4:** Differential gain and phase are measured using a Tektronix TSG120YC/NTSC signal generator and a Tektronix 1780R Video Measurement Set. The resolution of this equipment is 0.1% and 0.1°. Five identical amplifier stages were cascaded giving an effective resolution of 0.02% and 0.02°.

**Note 5:** Differential gain and phase are best when the control is set at 0% or 100%. See the Typical Performance Characteristics curves.

**Note 6:** Tested with R<sub>L</sub> = 150Ω to 2.5V to simulate an AC coupled load.

**Note 7:** Small-signal control path response is measured driving R<sub>C</sub> (Pin 5) to eliminate peaking caused by stray capacitance on Pin 4.

# TYPICAL PERFORMANCE CHARACTERISTICS

**LT1251**  
Gain vs Control Voltage

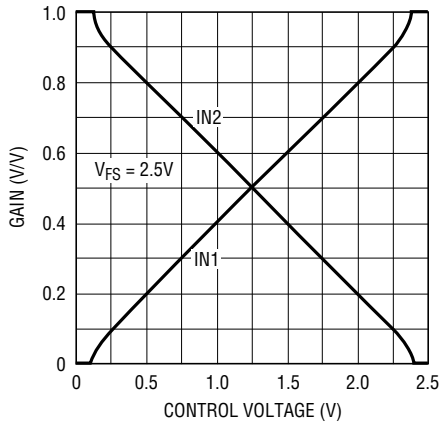

1251/56 G01

**LT1256**  
Gain vs Control Voltage

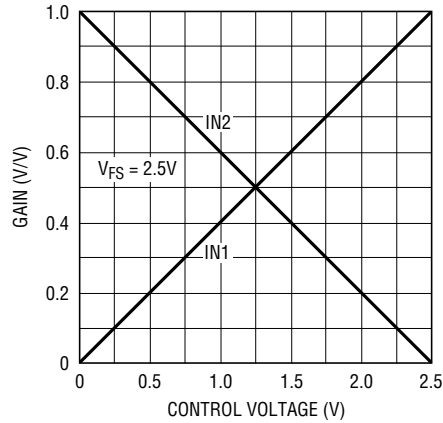

1251/56 G02

Spot Input Noise Voltage and Current vs Frequency

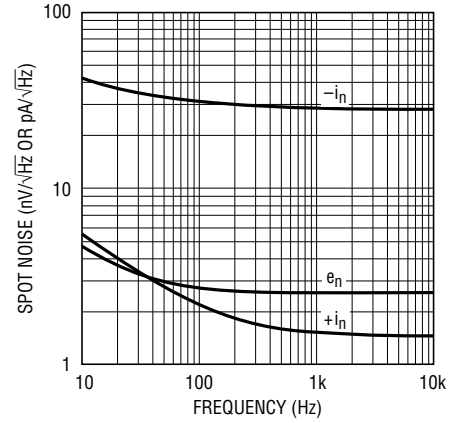

1251/56 G06

**LT1251/LT1256**  
Control Path Bandwidth

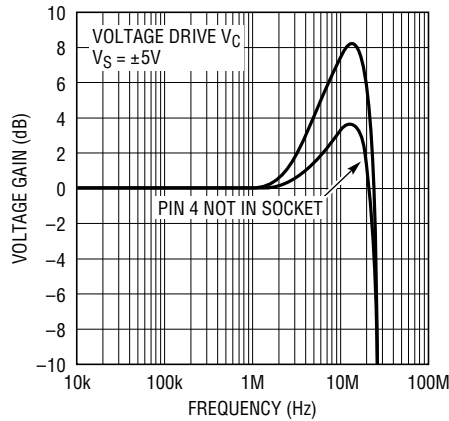

1251/56 G04

**LT1251/LT1256**  
Control Path Bandwidth

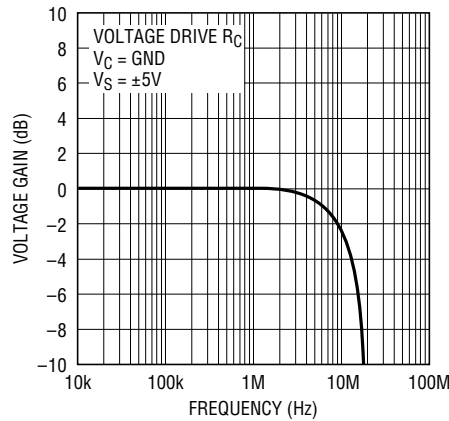

1251/56 G05

Undistorted Output Voltage vs Frequency

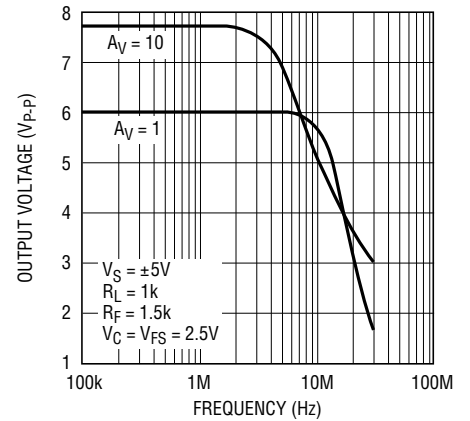

1251/56 G07

THD Plus Noise vs Frequency

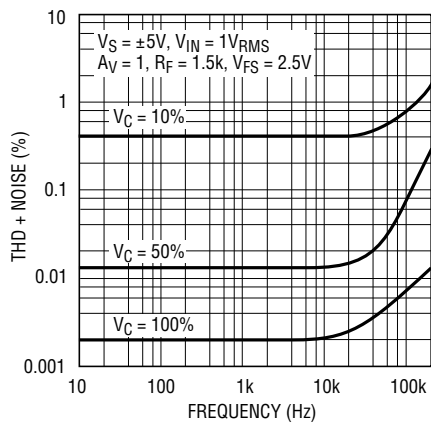

1251/56 G08

2nd and 3rd Harmonic Distortion vs Frequency

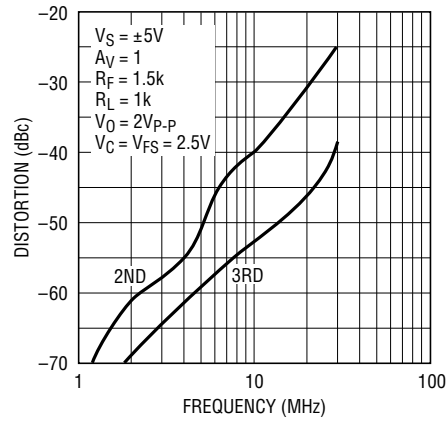

1251/56 G09

3rd Order Intercept vs Frequency

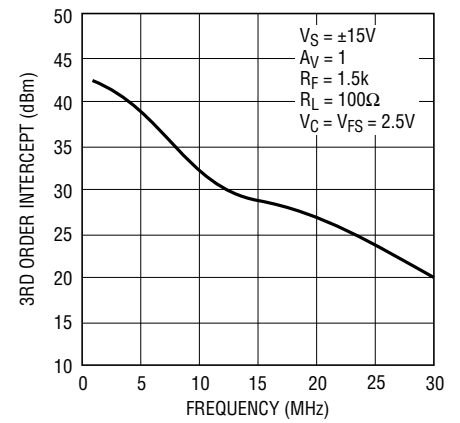

1251/56 G10

TYPICAL PERFORMANCE CHARACTERISTICS

**Bandwidth vs Feedback Resistance,  $A_V = 1$ ,  $R_L = 100\Omega$**

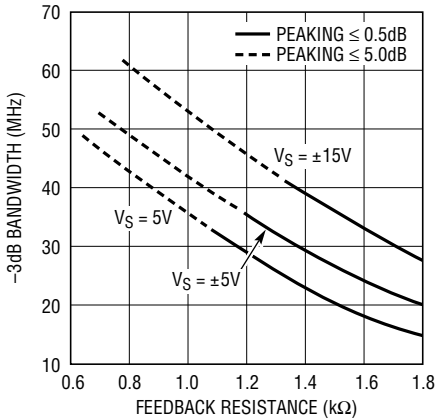

1251/56 G11

**Bandwidth vs Feedback Resistance,  $A_V = 1$ ,  $R_L = 1k$**

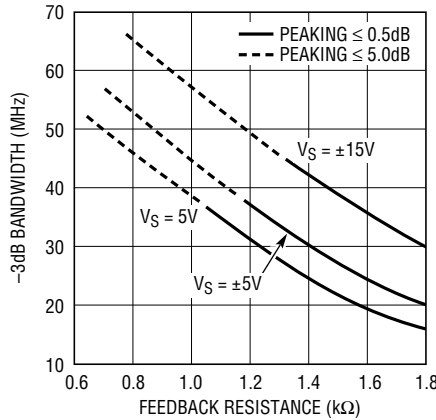

1251/56 G12

**Voltage Gain and Phase vs Frequency**

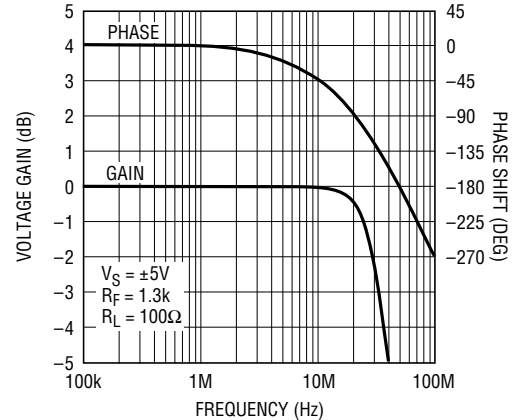

1251/56 G13

**Bandwidth vs Feedback Resistance,  $A_V = 10$ ,  $R_L = 100\Omega$**

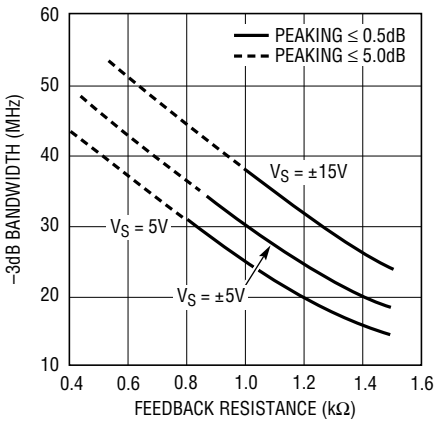

1251/56 G14

**Bandwidth vs Feedback Resistance,  $A_V = 10$ ,  $R_L = 1k$**

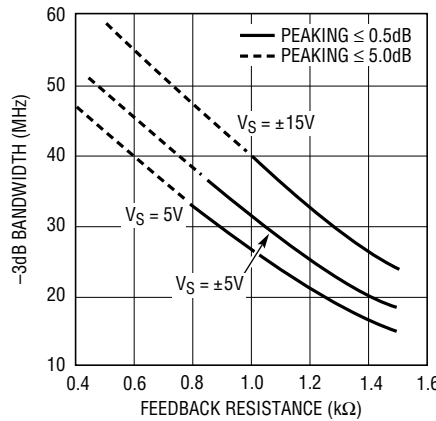

1251/56 G15

**Off-Channel Isolation vs Frequency**

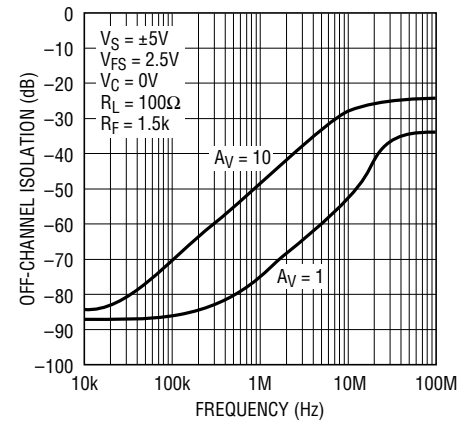

1251/56 G16

**Bandwidth vs Feedback Resistance,  $A_V = 100$ ,  $R_L = 100\Omega$**

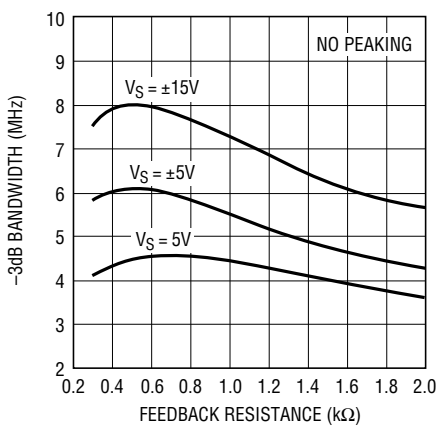

1251/56 G17

**Bandwidth vs Feedback Resistance,  $A_V = 100$ ,  $R_L = 1k$**

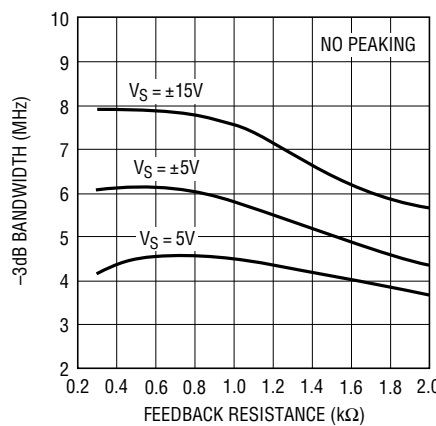

1251/56 G18

**-3dB Bandwidth vs Control Voltage**

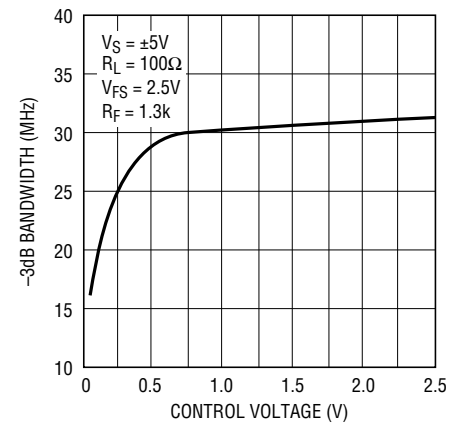

1251/56 G19

# TYPICAL PERFORMANCE CHARACTERISTICS

**Supply Current vs Full-Scale Voltage**

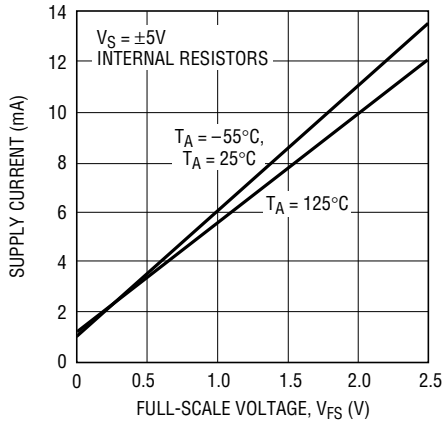

1251/56 G20

**Supply Current vs Full-Scale Current**

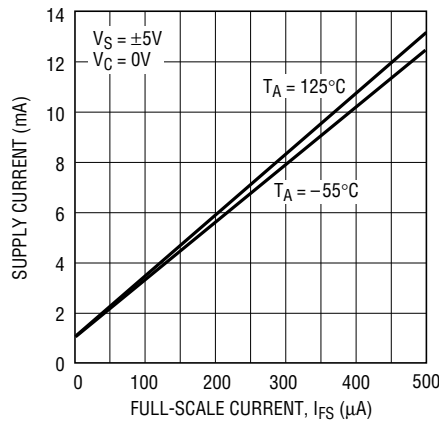

1251/56 G21

**Input Common Mode Range vs Temperature**

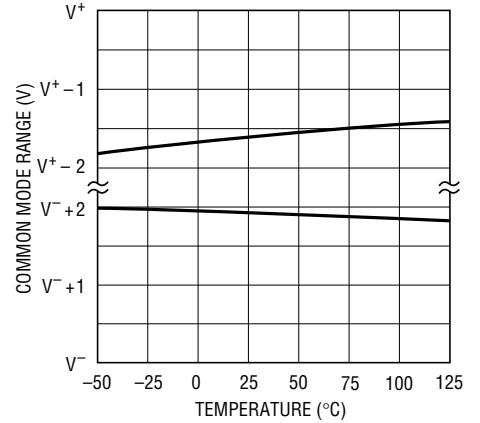

1251/56 G22

**Inverting Input Bias Current vs Null Voltage**

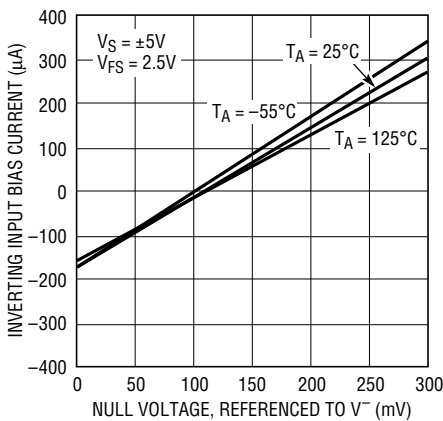

1251/56 G23

**Inverting Input Bias Current vs Null Voltage**

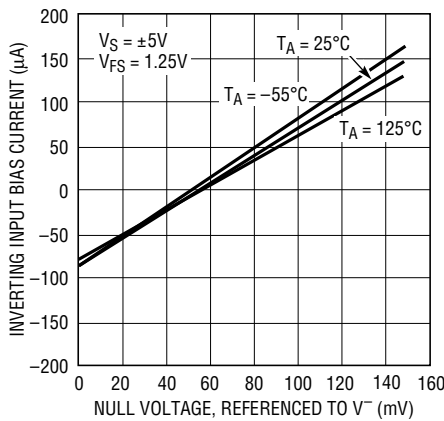

1251/56 G24

**Control and Full-Scale Amp Input Bias Current vs Input Voltage**

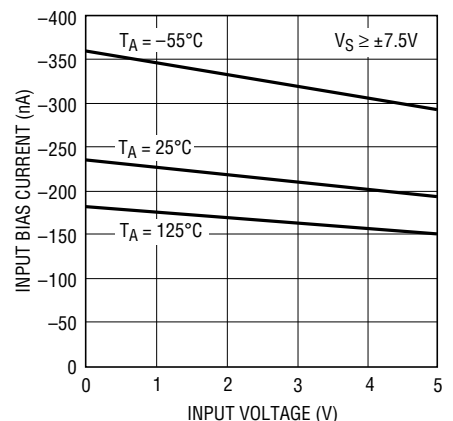

1251/56 G25

**Positive Output Saturation Voltage vs Load Current**

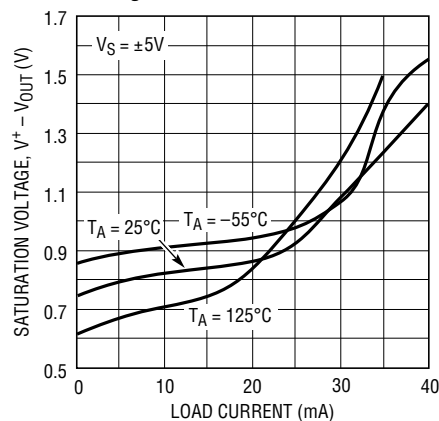

1251/56 G26

**Negative Output Saturation Voltage vs Load Current**

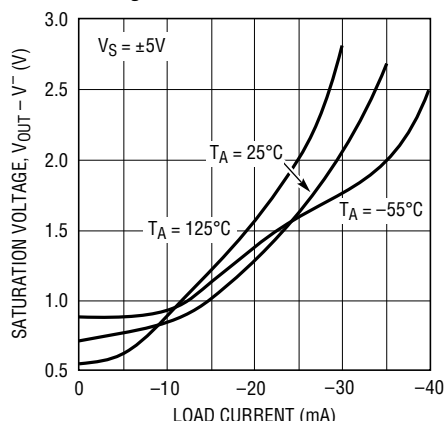

1251/56 G27

**Output Short-Circuit Current vs Temperature**

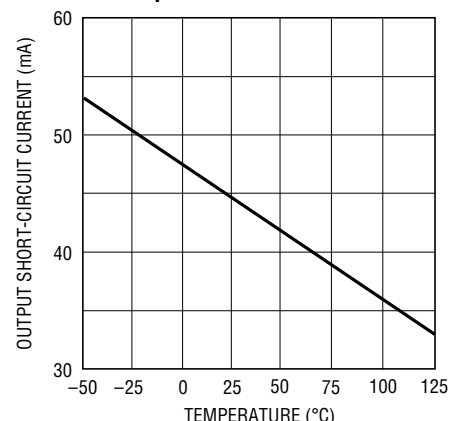

1251/56 G28

## TYPICAL PERFORMANCE CHARACTERISTICS

### Slew Rate vs Full-Scale Reference Voltage

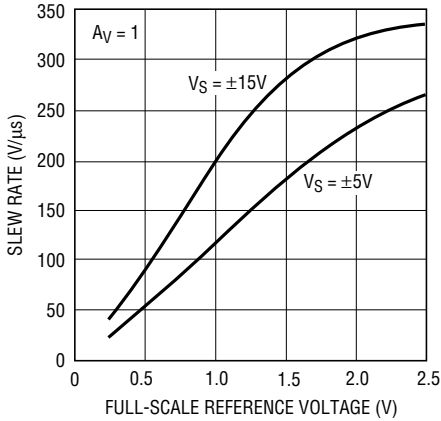

1251/56 G29

### Slew Rate vs Temperature

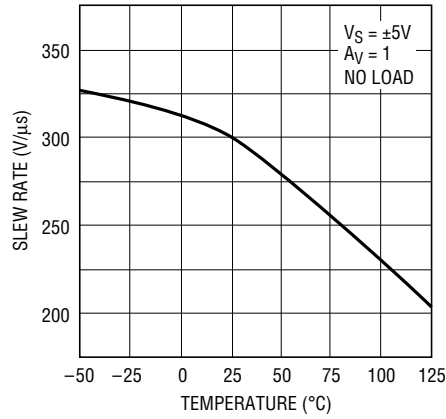

1251/56 G30

### Power Supply Rejection Ratio vs Frequency

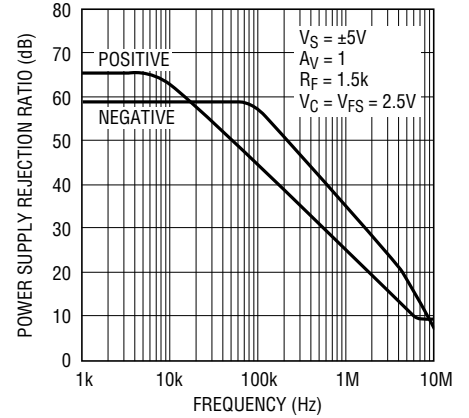

1251/56 G31

### Settling Time to 10mV vs Output Step

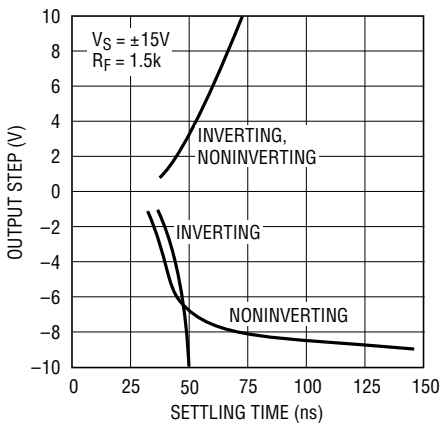

1251/56 G32

### Settling Time to 1mV vs Output Step

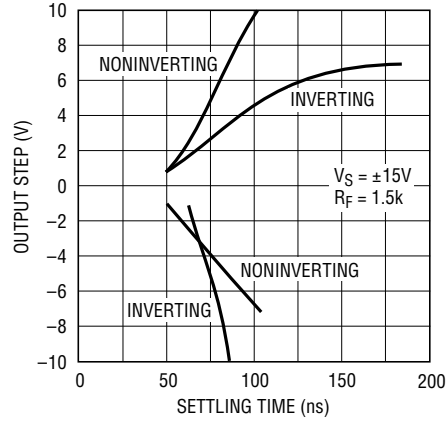

1251/56 G33

### Output Impedance vs Frequency

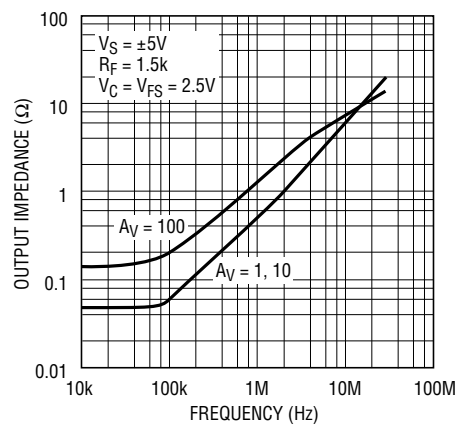

1251/56 G34

### Differential Gain vs Controlled Gain

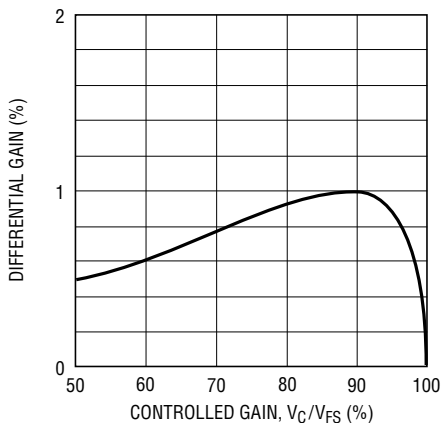

1251/56 G35

### Differential Phase vs Controlled Gain

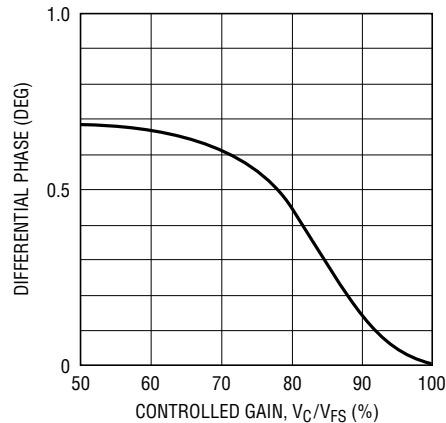

1251/56 G36

### LT1251 Switching Transient (Glitch)

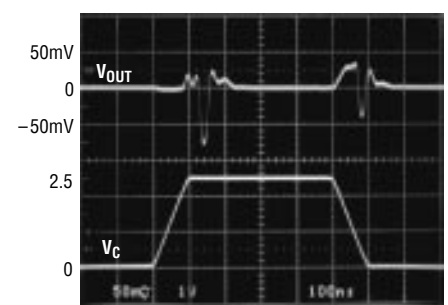

$V_{FS} = 2.5V$   
 $R_{F1} = R_{F2} = 1.5k$   
 $V_S = \pm 5V$

1251/56 G37



**SIMPLIFIED SCHEMATIC**

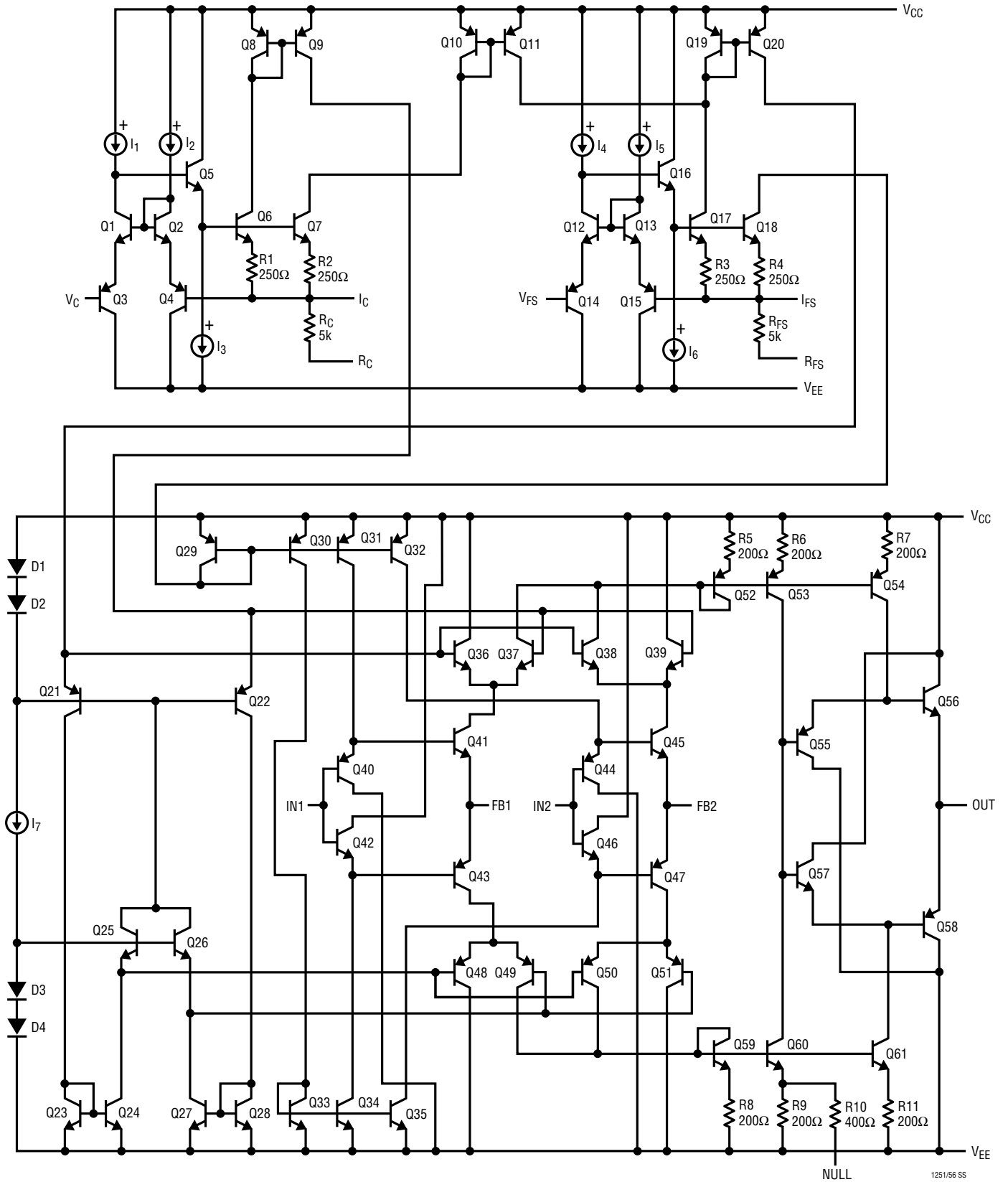

1251/56 SS

## APPLICATIONS INFORMATION

### Supply Voltage

The LT1251/LT1256 are high speed amplifiers. To prevent problems, use a ground plane with point-to-point wiring and small bypass capacitors (0.01 $\mu$ F to 0.1 $\mu$ F) at each supply pin. For good settling characteristics, especially driving heavy loads, a 4.7 $\mu$ F tantalum within an inch or two of each supply pin is recommended.

The LT1251/LT1256 can be operated on single or split supplies. The minimum total supply is 4V (Pins 7 to 9). However, the input common mode range is only guaranteed to within 2V of each supply. On a 4V supply the parts must be operated in the inverting mode with the noninverting input biased half way between Pin 7 and Pin 9. See the Typical Applications section for the proper biasing for single supply operation.

The op amps in the control section operate from  $V^-$  (Pin 7) to within 2V of  $V^+$  (Pin 9). For this reason the positive supply should be 4.5V or greater in order to use 2.5V control and full-scale voltages.

### Inputs

The noninverting inputs (Pins 1 and 14) are easy to drive since they look like a 17M resistor in parallel with a 1.5pF capacitor at most frequencies. However, the input stage can oscillate at very high frequencies (100MHz to 200MHz) if the source impedance is inductive (like an unterminated cable). Several inches of wire look inductive at these high frequencies and can cause oscillations. Check for oscillations at the inverting inputs (Pins 2 and 13) with a 10 $\times$  probe and a 200MHz oscilloscope. A small capacitor (10pF to 50pF) from the input to ground or a small resistor (100 $\Omega$  to 300 $\Omega$ ) in series with the input will stop these parasitic oscillations, even when the source is inductive. These components must be within an inch of the IC in order to be effective.

All of the inputs to the LT1251/LT1256 have ESD protection circuits. During normal operation these circuits have no effect. If the voltage between the noninverting and inverting inputs exceeds 6V, the protection circuits will trigger and attempt to short the inputs together. This condition will continue until the voltage drops to less than

500mV or the current to less than 10mA. If a very fast edge is used to measure settling time with an input step of more than 6V, the protection circuits will cause the 1mV settling time to become hundreds of microseconds.

### Feedback Resistor Selection

The feedback resistor value determines the bandwidth of the LT1251/LT1256 as in other current feedback amplifiers. The curves in the Typical Performance Characteristics show the effect of the feedback resistor on small-signal bandwidth for various loads, gains and supply voltages. The bandwidth is limited at high gains by the 500MHz to 800MHz gain-bandwidth product as shown in the curves. Capacitance on the inverting input will cause peaking and increase the bandwidth. Take care to minimize the stray capacitance on Pins 2 and 13 during printed circuit board layout for flat response.

If the two input stages are not operating with equal gain, the gain versus control voltage characteristic will be nonlinear. This is true even if  $R_{F1}$  equals  $R_{F2}$ . This is because the open-loop characteristic of a current feedback amplifier is dependent on the Thevenin impedance at the inverting input. For linear control of the gain, the loop gain of the two stages must be equal. For an extreme example, let's take a gain of 101 on input 1,  $R_{F1} = 1.5k$  and  $R_{G1} = 15\Omega$ , and unity-gain on input 2,  $R_{F2} = 1.5k$ . The curve in Figure 1 shows about 25% error at midscale. To eliminate this nonlinearity we must change the value of  $R_{F2}$ . The correct value is the Thevenin impedance at inverting input 1 (including the internal resistance of 27 $\Omega$ ) times the gain set at input 1. For a linear gain versus control voltage characteristic when input 2 is operating at unity-gain, the formula is:

$$R_{F2} = (A_{V1})(R_{F1} \parallel R_{G1} + 27)$$

$$R_{F2} = (101)(14.85 + 27) = 4227$$

Because the feedback resistor of the unity-gain input is increased, the bandwidth will be lower and the output noise will be higher. We can improve this situation by reducing the values of  $R_{F1}$  and  $R_{G1}$ , but at high gains the internal 27 $\Omega$  dominates.

## APPLICATIONS INFORMATION

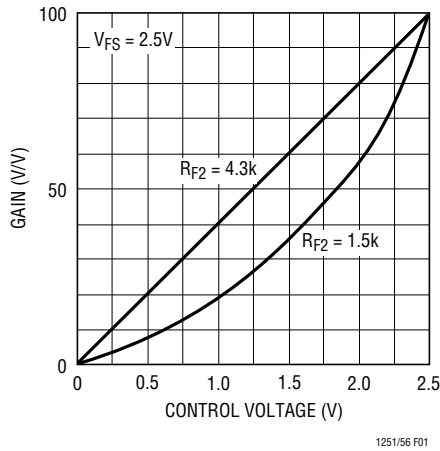

Figure 1. Linear Gain Control from 0 to 101

### Capacitive Loads

Increasing the value of the feedback resistor reduces the bandwidth and open-loop gain of the LT1251/LT1256; therefore, the pole introduced by a capacitive load can be overcome. If there is little or no resistive load in parallel with the load capacitance, the output stage will resonate, peak and possibly oscillate. With a resistive load of  $150\Omega$ , any capacitive load can be accommodated by increasing the feedback resistor. If the capacitive load cannot be paralleled with a DC load of  $150\Omega$ , a network of  $200pF$  in series with  $100\Omega$  should be placed from the output to ground. Then the feedback resistor should be selected for best response.

### The Null Pin

Pin 6 can be used to adjust the gain of an internal current mirror to change the output offset. The open circuit voltage at Pin 6 is set by the full scale current  $I_{FS}$  flowing through  $200\Omega$  to the negative supply. Therefore, the NULL pin sits  $100mV$  above the negative supply with  $V_{FS}$  equal to  $2.5V$ . Any op amp whose output swings within a few

millivolts of the negative supply can drive the NULL pin. The AM modulator application shows an LT1077 driving the NULL pin to eliminate the output DC offset voltage.

### Crosstalk

The amount of signal from the off input that appears at the output is a function of frequency and the circuit topology. The nature of a current feedback input stage is to force the voltage at the inverting input to be equal to the voltage at the noninverting input. This is independent of feedback and forced by a buffer amplifier between the inputs. When the LT1251/LT1256 are operating noninverting, the off input signal is present at the inverting input. Since one end of the feedback resistor is connected to this input, the off signal is only a feedback resistor away from the output. The amount of unwanted signal at the output is determined by the size of the feedback resistor and the output impedance of the LT1251/LT1256. The output impedance rises with increasing frequency resulting in more crosstalk at higher frequencies. Additionally, the current that flows in the inverting input is diverted to the supplies within the chip and some of this signal will also show up at the output. With a  $1.5k$  feedback resistor, the crosstalk is down about  $86dB$  at low frequencies and rises to  $-78dB$  at  $1MHz$  and on to  $-60dB$  at  $6MHz$ . The curves show the details.

### Distortion

When only one input is contributing to the output ( $V_C = 0\%$  or  $100\%$ ) the LT1251/LT1256 have very low distortion. As the control reduces the output, the distortion will increase. The amount of increase is a function of the current that flows in the inverting input. Larger input signals generate more distortion. Using a larger feedback resistor will reduce the distortion at the expense of higher output noise.

## APPLICATIONS INFORMATION

### Signal Path Description

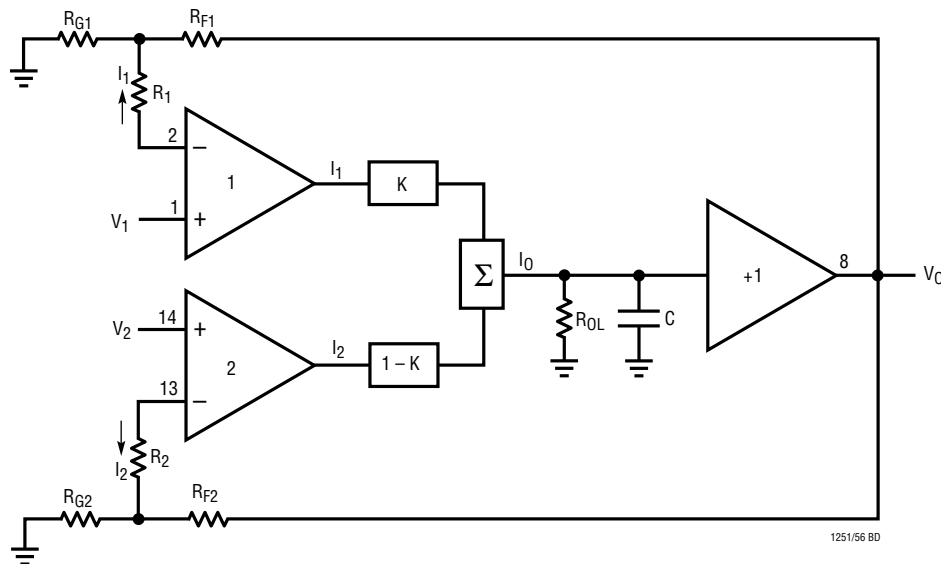

Figure 2. Signal Path Block Diagram

Figure 2 is the basic block diagram of the LT1251/LT1256 signal path with external resistors  $R_{G1}$ ,  $R_{F1}$ ,  $R_{G2}$  and  $R_{F2}$ . Both input stages are operating as noninverting amplifiers with two input signals  $V_1$  and  $V_2$ .

Each input stage has a unity-gain buffer from the noninverting input to the inverting input. Therefore, the inverting input is at the same voltage as the noninverting input.  $R_1$  and  $R_2$  represent the internal output resistances of these buffers, approximately  $27\Omega$ .

$K$  is a constant determined by the control circuit and can be any value between 0 and 1. The control circuit is described in a later section.

By inspection of the diagram:

$$I_1 = \frac{V_1}{R_1 + \frac{(R_{G1})(R_{F1})}{R_{G1} + R_{F1}}} - \frac{V_0}{R_{F1} + R_1 \left( \frac{R_{F1}}{R_{G1}} + 1 \right)}$$

$$I_2 = \frac{V_2}{R_2 + \frac{(R_{G2})(R_{F2})}{R_{G2} + R_{F2}}} - \frac{V_0}{R_{F2} + R_2 \left( \frac{R_{F2}}{R_{G2}} + 1 \right)}$$

$$I_0 = KI_1 + (1-K)I_2$$

$$V_0 = I_0 \left( \frac{R_{OL}}{1 + sR_{OL}C} \right)$$

Substituting and rearranging gives:

$$V_0 = \frac{\frac{KV_1}{R_1 + \frac{(R_{G1})(R_{F1})}{R_{G1} + R_{F1}}} + \frac{(1-K)V_2}{R_2 + \frac{(R_{G2})(R_{F2})}{R_{G2} + R_{F2}}}}{\frac{1 + sR_{OL}C}{R_{OL}} + \frac{K}{R_{F1} + R_1 \left( \frac{R_{F1}}{R_{G1}} + 1 \right)} + \frac{(1-K)}{R_{F2} + R_2 \left( \frac{R_{F2}}{R_{G2}} + 1 \right)}}$$

General Equation for the Noninverting Amplifier Case

## APPLICATIONS INFORMATION

In low gain applications,  $R_1$  and  $R_2$  are small compared to the feedback resistors and therefore we can simplify the equation to:

$$V_0 = \frac{\frac{KV_1}{(R_{G1})(R_{F1})} + \frac{(1-K)V_2}{(R_{G2})(R_{F2})}}{\frac{R_{G1} + R_{F1}}{1 + sR_{OL}C} + \frac{K}{R_{F1}} + \frac{(1-K)}{R_{F2}}}$$

Note that the denominator causes a gain error due to the open-loop gain (typically 0.1% for frequencies below 20kHz) and for mismatches in  $R_{F1}$  and  $R_{F2}$ . A 1% mismatch in the feedback resistors results in a 0.25% error at  $K = 0.5$ .

If we set  $R_{F1} = R_{F2}$  and assume  $R_{OL} \gg R_{F1}$  (a 0.1% error at low frequencies) the above equation simplifies to:

$$V_0 = KV_1A_{V1} + (1-K)V_2A_{V2}$$

where  $A_{V1} = 1 + \frac{R_{F1}}{R_{G1}}$  and  $A_{V2} = 1 + \frac{R_{F2}}{R_{G2}}$

This shows that the output fades linearly from input 2, times its gain, to input 1, times its gain, as  $K$  goes from 0 to 1.

If only one input is used (for example,  $V_1$ ) and Pin 14 is grounded, then the gain is proportional to  $K$ .

$$\frac{V_0}{V_1} = KA_{V1}$$

Similarly for the inverting case where the noninverting inputs are grounded and the input voltages  $V_1$  and  $V_2$  drive the normally grounded ends of  $R_{G1}$  and  $R_{G2}$ , we get:

$$V_0 = -\frac{\frac{KV_1}{R_{G1} + R_1\left(\frac{R_{G1}}{R_{F1}} + 1\right)} + \frac{(1-K)V_2}{R_{G2} + R_2\left(\frac{R_{G2}}{R_{F2}} + 1\right)}}{\frac{1 + sR_{OL}C}{R_{OL}} + \frac{K}{R_{F1} + R_1\left(\frac{R_{F1}}{R_{G1}} + 1\right)} + \frac{(1-K)}{R_{F2} + R_2\left(\frac{R_{F2}}{R_{G2}} + 1\right)}}$$

### General Equation for the Inverting Amplifier Case

Note that the denominator is the same as the noninverting case. In low gain applications,  $R_1$  and  $R_2$  are small compared to the feedback resistors and therefore we can simplify the equation to:

$$V_0 = -\frac{\frac{KV_1}{R_{G1}} + \frac{(1-K)V_2}{R_{G2}}}{\frac{1 + sR_{OL}C}{R_{OL}} + \frac{K}{R_{F1}} + \frac{(1-K)}{R_{F2}}}$$

Again, if we set  $R_{F1} = R_{F2}$  and assume  $R_{OL} \gg R_{F1}$  (a 0.1% error at low frequencies) the above equation simplifies to:

$$V_0 = -[KV_1A_{V1} + (1-K)V_2A_{V2}]$$

where  $A_{V1} = \frac{R_{F1}}{R_{G1}}$  and  $A_{V2} = \frac{R_{F2}}{R_{G2}}$

The 4-resistor difference amplifier yields the same result as the inverting amplifier case, and the common mode rejection is independent of  $K$ .

## APPLICATIONS INFORMATION

### Control Circuit Description

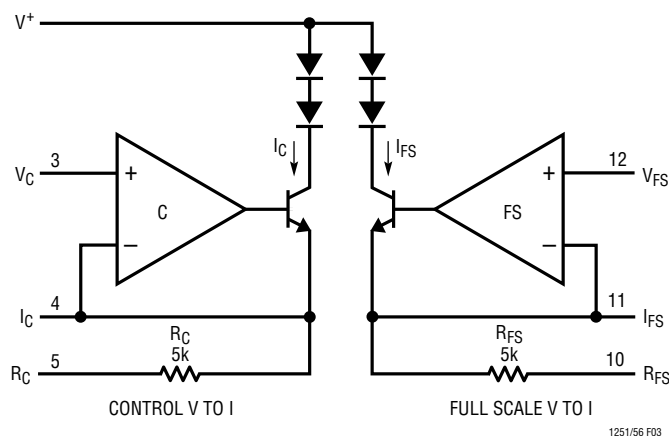

Figure 3. Control Circuit Block Diagram

The control section of the LT1251/LT1256 consists of two identical voltage-to-current converters (V-to-I); each V-to-I contains an op amp, an NPN transistor and a resistor. The converter on the right generates a *full-scale* current  $I_{FS}$  and the one on the left generates a *control* current  $I_C$ . The ratio  $I_C/I_{FS}$  is called  $K$ .  $K$  goes from a minimum of zero (when  $I_C$  is zero) to a maximum of one (when  $I_C$  is equal to, or greater than,  $I_{FS}$ ).  $K$  determines the gain from each signal input to the output.

The op amp in each V-to-I drives the transistor until the voltage at the inverting input is the same as the voltage at the noninverting input. If the open end of the resistor (Pin 5 or 10) is grounded, the voltage across the resistor is the same as the voltage at the noninverting input. The emitter current is therefore equal to the input voltage  $V_C$  divided by the resistor value  $R_C$ . The collector current is essentially the same as the emitter current and it is the ratio of the two collector currents that sets the gain.

The LT1251/LT1256 are tested with Pins 5 and 10 grounded and a full-scale voltage of 2.5V applied to  $V_{FS}$  (Pin 12). This sets  $I_{FS}$  at approximately 500 $\mu$ A; the control voltage  $V_C$  is applied to Pin 3. When the control voltage is negative or zero,  $I_C$  is zero and  $K$  is zero. When  $V_C$  is 2.5V or greater,  $I_C$  is equal to or greater than  $I_{FS}$  and  $K$  is one. The gain of channel one goes from 0% to 100% as  $V_C$  goes from zero to 2.5V. The gain of channel two goes the opposite way, from 100% down to 0%. The worst-case error in  $K$  (the

gain) is  $\pm 3\%$  as detailed in the electrical tables. By using a 2.5V full-scale voltage and the internal resistors, no additional errors need be accounted for.

In the LT1256,  $K$  changes linearly with  $I_C$ . To insure that  $K$  is zero,  $V_C$  must be negative 15mV or more to overcome the worst-case control op amp offset. Similarly to insure that  $K$  is 100%,  $V_C$  must be 3% larger than  $V_{FS}$  based on the guaranteed gain accuracy.

To eliminate the overdrive requirement, the LT1251 has internal circuitry that senses when the control current is at about 5% and sets  $K$  to 0%. Similarly, at about 95% it sets  $K$  to 100%. The LT1251 guarantees that a 2% (50mV) input gives zero and 98% (2.45V) gives 100%.

The operating currents of the LT1251/LT1256 are derived from  $I_{FS}$  and therefore the quiescent current is a function of  $V_{FS}$  and  $R_{FS}$ . The electrical tables show the supply current for three values of  $V_{FS}$  including zero. An approximate formula for the supply current is:

$$I_S = 1\text{mA} + (24)(I_{FS}) + (V_S/20\text{k})$$

where  $V_S$  is the total supply voltage between Pins 9 and 7. By reducing  $I_{FS}$  the supply current can be reduced, however, the slew rate and bandwidth will also be reduced as indicated in the characteristic curves. Using the internal resistors (5k) with  $V_{FS}$  equal to 2.5V results in  $I_{FS}$  equal to 500 $\mu$ A; there is no reason to use a larger value of  $I_{FS}$ .

The inverting inputs of the V-to-I converters are available so that external resistors can be used instead of the internal ones. For example, if a 10V full-scale voltage is desired, an external pair of 20k resistors should be used to set  $I_{FS}$  to 500 $\mu$ A. The positive supply voltage must be 2.5V greater than the maximum  $V_C$  and/or  $V_{FS}$  to keep the transistors from saturating. Do not use the internal resistors with external resistors because the internal resistors have a large positive temperature coefficient (0.2%/°C) that will cause gain errors.

If the control voltage is applied to the free end of resistor  $R_C$  (Pin 5) and the  $V_C$  input (Pin 3) is grounded, the polarity of the control voltage must be inverted. Therefore,  $K$  will be 0% for zero input and 100% for  $-2.5$ V input, assuming  $V_{FS}$  equals 2.5V. With Pin 3 grounded, Pin 4 is a virtual ground; this is convenient for summing several negative going control signals.

# TYPICAL APPLICATIONS

### AM Modulator with DC Output Nulling Circuit

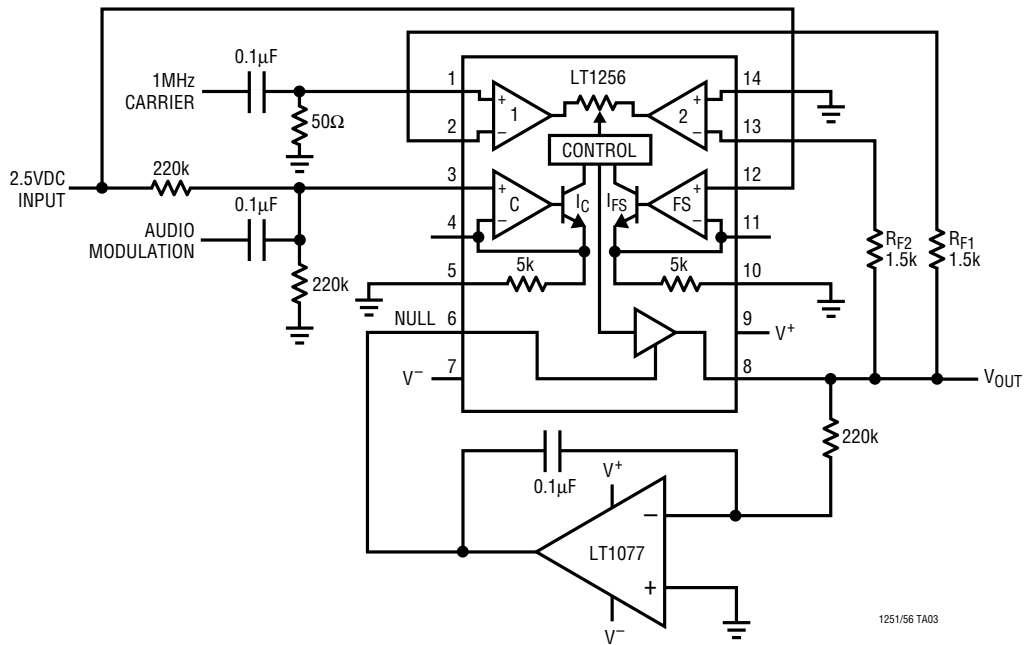

### Single Supply Inverting AC Amplifier

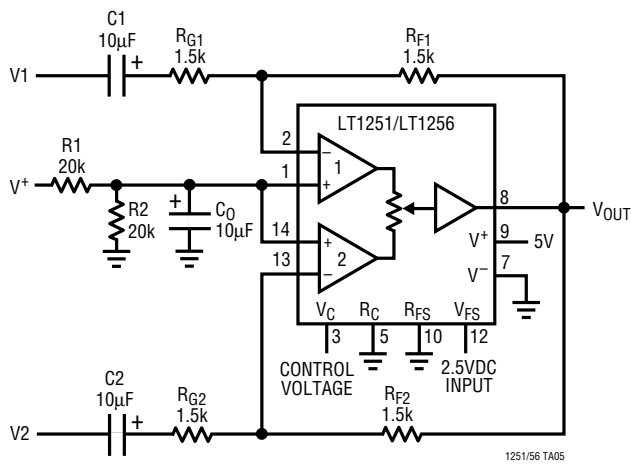

### Single Supply Noninverting AC Amplifier with Digital Gain Control

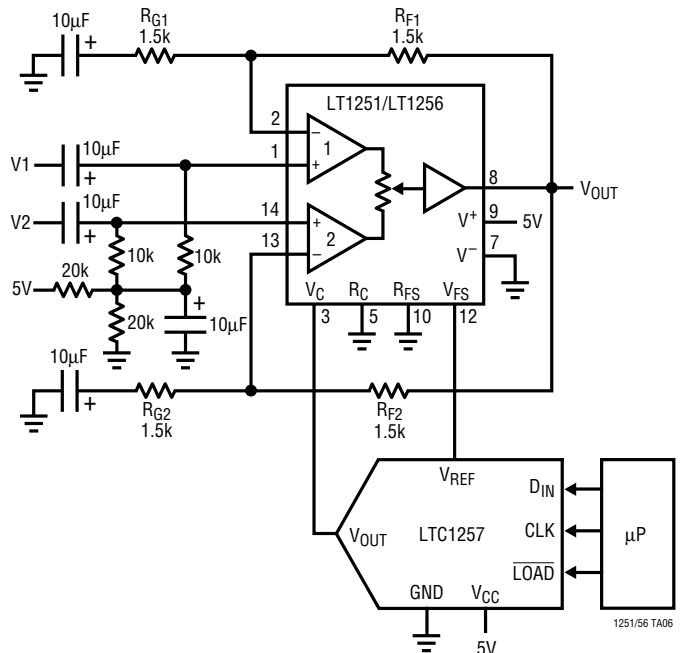

**TYPICAL APPLICATIONS**

**Controlled Gain, Voltage-to-Current Converter  
(Current Source)**

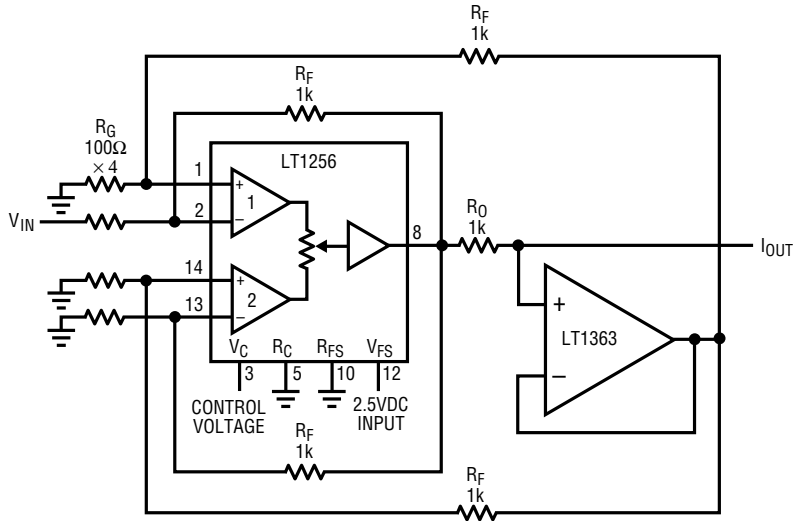

$$I_{OUT} = \frac{V_{IN}}{R_0} \left( \frac{R_F}{R_G} \right) \frac{V_C}{V_{FS}}$$

OUTPUT RESISTANCE DEPENDS ON MATCHING OF RESISTORS

1251/56 TA09

**Variable Lowpass, Highpass and Allpass Filter**

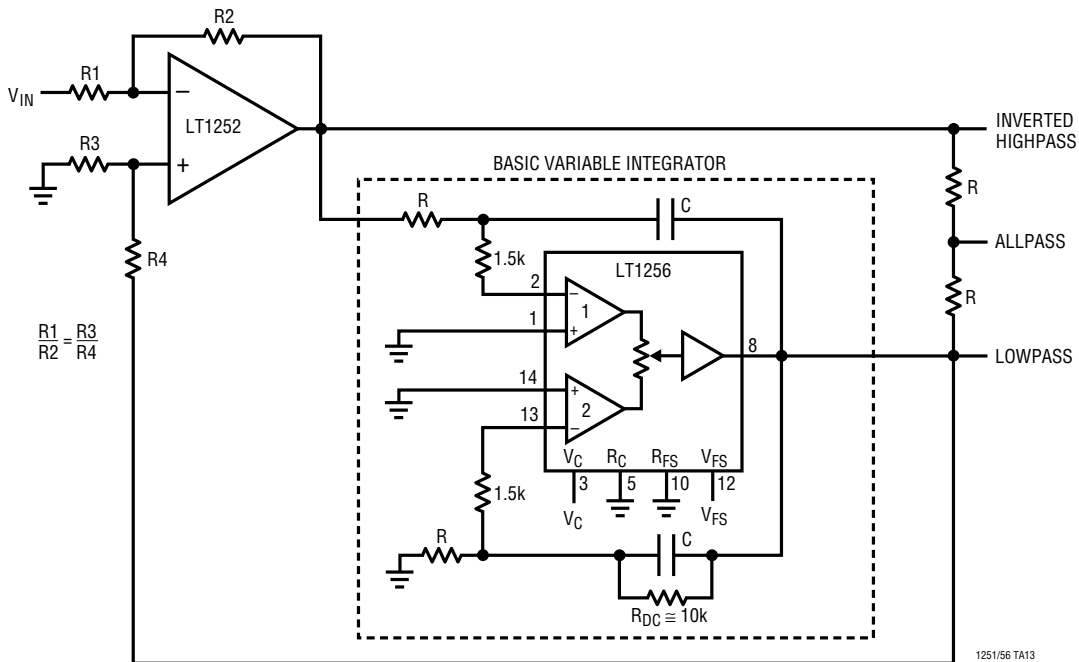

1251/56 TA13



# TYPICAL APPLICATIONS

Logarithmic Gain Control (Noninverting)

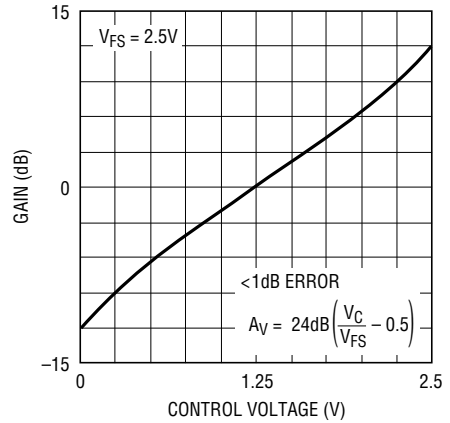
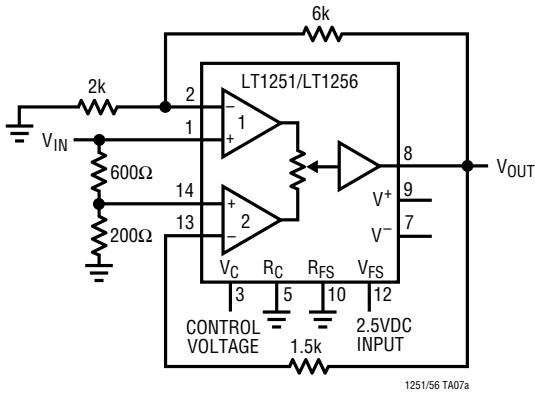

Logarithmic Gain Control (Inverting)

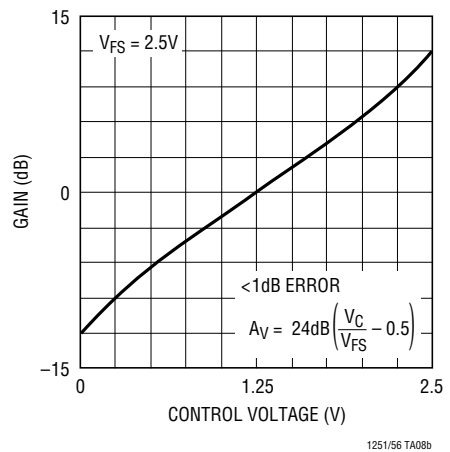
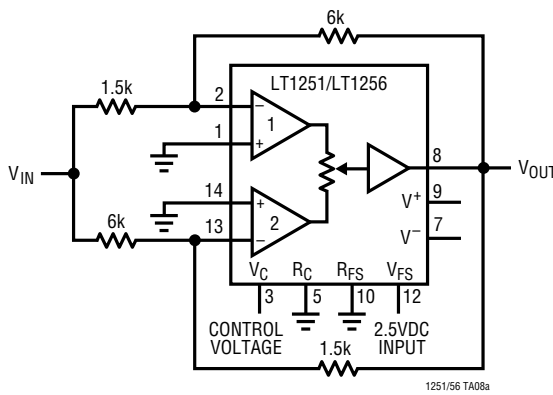

1MHz Wien Bridge Oscillator

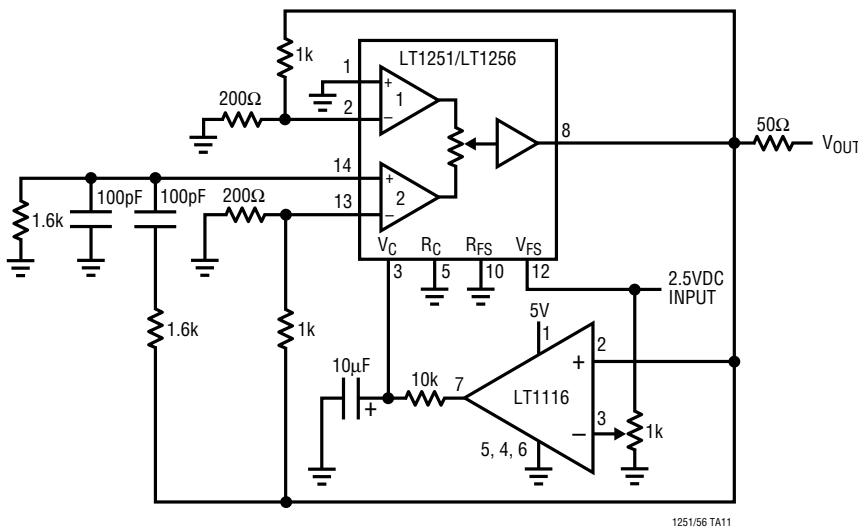

Basic Variable Integrator

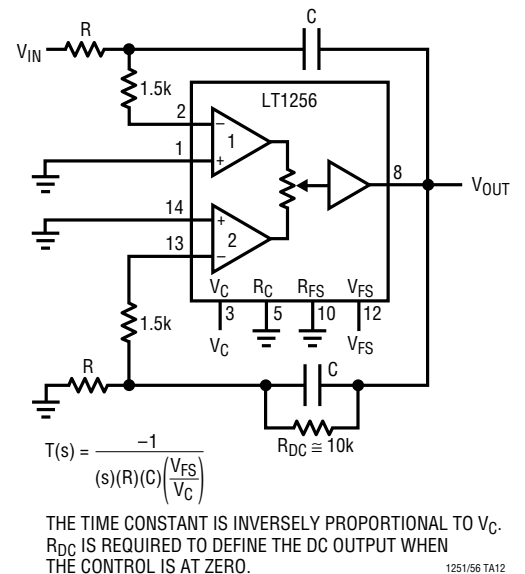

TYPICAL APPLICATIONS

3.58MHz Phase Shifter

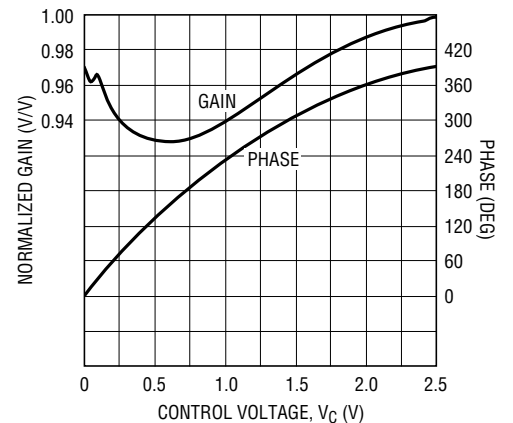
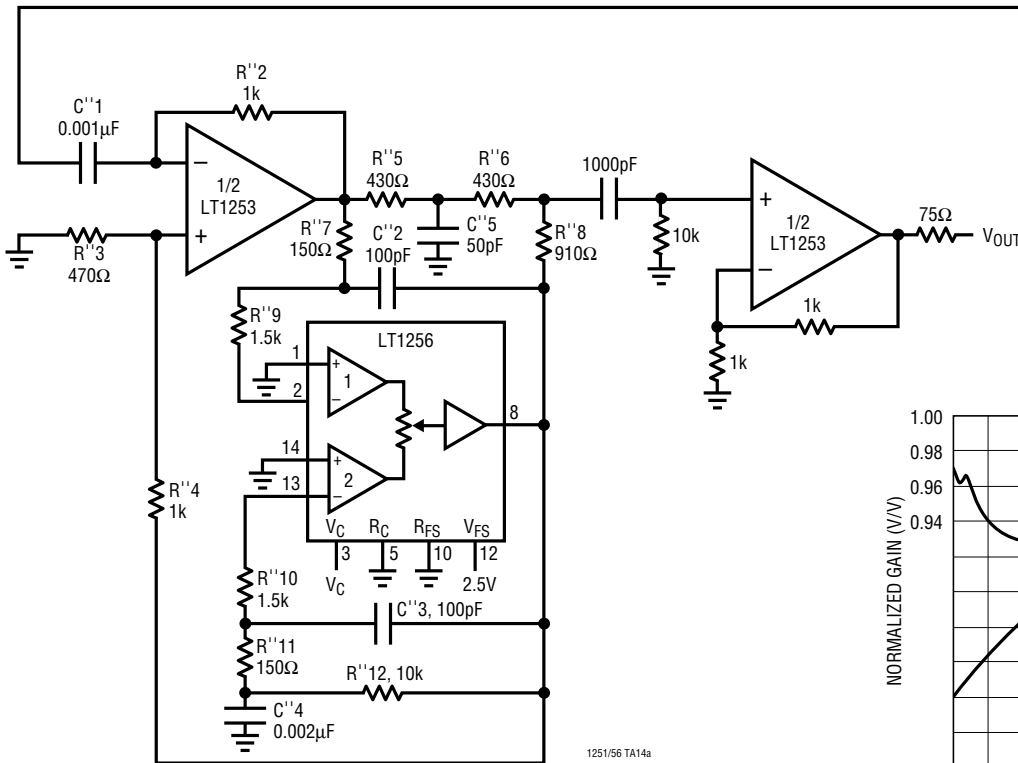
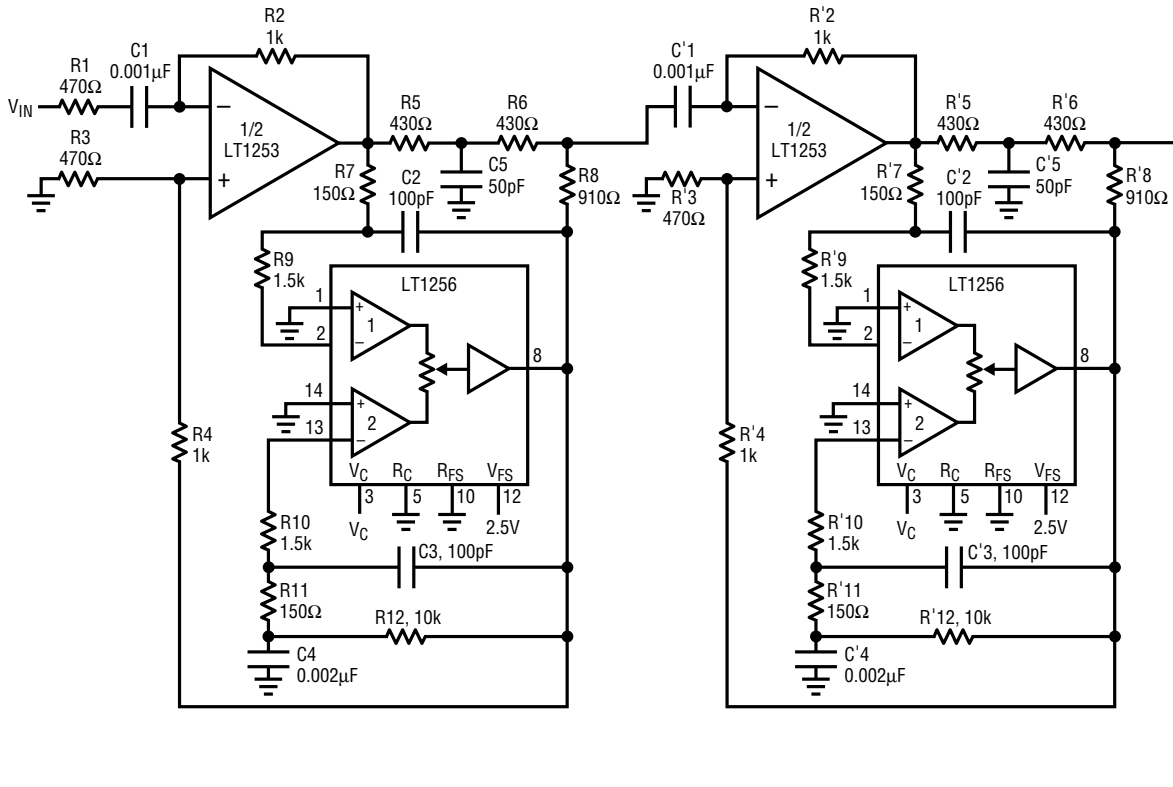

1251/56 TA14a

1251/56 TA14b

# TYPICAL APPLICATIONS

## State Variable Filter with Adjustable Frequency and Q

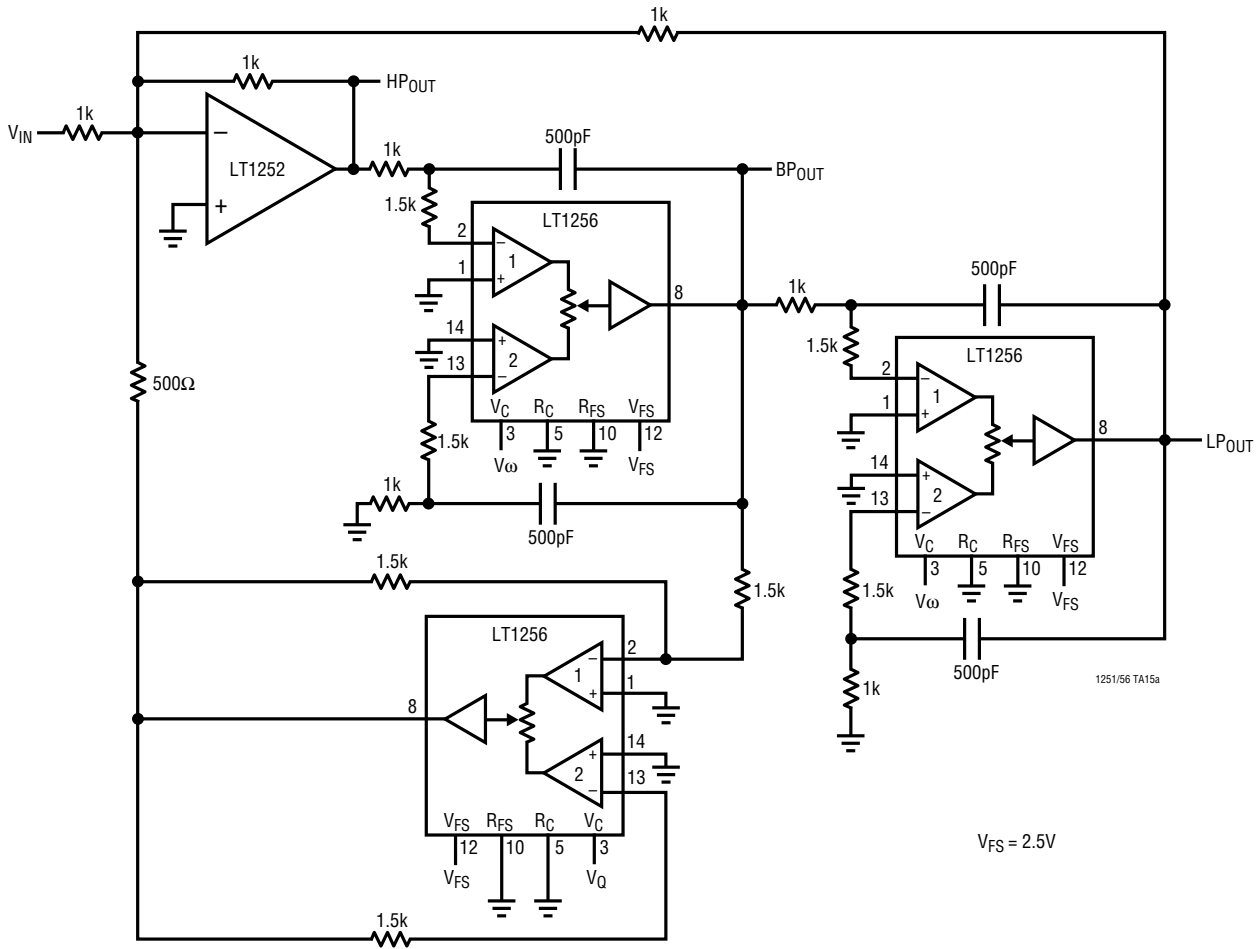

$V_{FS} = 2.5V$

Center Frequency vs Control Voltage  $V_{\omega}$

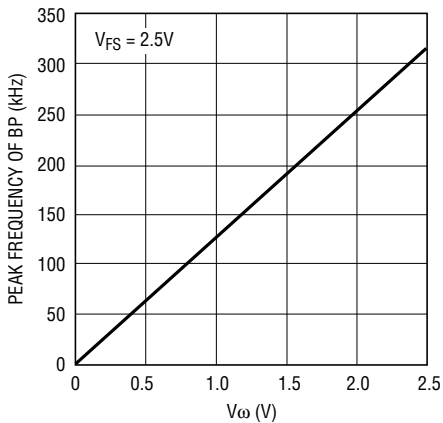

1251/56 TA15b

Q vs Control Voltage  $V_Q$

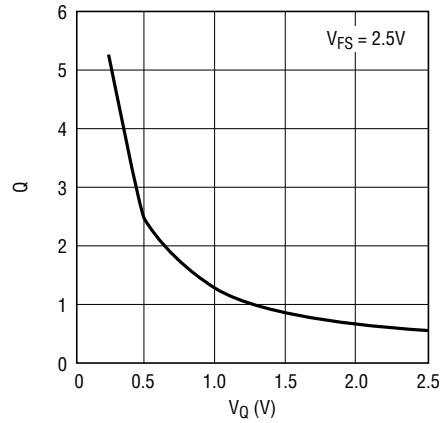

1251/56 TA15c

# LT1251/LT1256

---

## MACROMODEL

### For PSpice™

```
*
* Linear Technology LT1251/LT1256 VIDEO FADER MACROMODEL
* Written: 3-11-1994 BY WILLIAM H. GROSS.
* Corrected: 7-15-1996
* Connections: as per datasheet pinout
*1=first noninverting input
*2=first inverting input
*3=control voltage input
*4=control current input
*5=control resistor, RC
*6=null input
*7=negative supply
*8=output
*9=positive supply
*10=full scale resistor, RFS
*11=full scale current input
*12=full scale voltage input
*13=second inverting input
*14=second noninverting input
*
.SUBCKT LT1251 1 2 3 4 5 6 7 8 9 10 11 12 13 14
*
*first input stage
IB1      1      0      500NA
RI1      1      0      17MEG
C1       1      0      1.5PF
E1       2A     0      VALUE={LIMIT (V(1), V(8N)+0.4, V(8P)-0.4)+V(EN)/30}
VOS1     2A     2B     2.5MV
R1       2B     2      27
C2       2      0      1PF
*
*second input stage
IB2      14     0      450NA
RI2      14     0      17MEG
C14     14     0      1.5PF
E2       13A    0      VALUE={LIMIT (V(14), V(8N)+0.4, V(8P)-0.4)+V(EN)/30}
VOS2     13A    13B    1.5MV
R2       13B    13     27
C13     13     0      1PF
*
*control amp
IBC      3      0      -300NA
RIC      3      0      100MEG
C3       3      0      1PF
R3       3      3A     1600
CBWC     3A     0      10PF
EC       3B     0      3A      0      1.0
VOSC     3B     4      5MV
C4       4      0      1PF
RC       4      5      5K
C5       5      0      1PF
*
```

---

PSpice is a trademark of MicroSim Corporation

**MACROMODEL**

```

*full scale amp
IBFS  12    0    -300NA
RIFS  12    0    100MEG
C12   12    0    1PF
R12   12    12A  1600
CBWFS 12A   0    10PF
EFS   12B   0    12A   0    1.0
VOSFS 12B   11   -5MV
C11   11    0    1PF
RFS   11    10   5K
C10   10    0    1PF
*
*generating K
*** the next two lines are for the LT1251
EK K 0 TABLE {I(VOSC)/I(VOSFS)}= (-100,0) (0.04,0) (0.1,0.11)
+ (0.9,0.907) (0.95,1.0) (100,1.0)
*** the next two lines are for the LT1256
*EK K 0 TABLE {I(VOSC)/I(VOSFS)}= (-100,0) (0,0) (0.2,0.21)
*+ (0.9,0.9) (1.0,1.0) (100,1.0)
RDUMMY K 0 1MEG
RNOISE1 EN 0 200K
RNOISE2 EN 0 200K
*generates 40.7nV/rtHz
*
*null circuit
GNULL 7 6A VALUE={I(VOSFS)}
RN1 6A 7 200
VNULL 6A 6B 0.0V
RN2 6B 6 400
C6 6 7 1PF
*
*output stage
E6 8A 0
+VALUE={1.8MEG*(I(VOS1)*V(K)+I(VOS2)*(1-V(K))-I(VNULL)+0.10UA+0.0007*V(EN))}
RG 8A 8B 1.8MEG
CG 8B 0 3.4PF
E8 8C 0 8B 0 1.0
V8 8C 8D 0.0V
R8 8D 8 11
*
*output swing and current limit
DP 8B 8P D1
VDP 8P 9 -1.4V
DN 8N 8B D1
VDN 8N 7 1.4V
.MODEL D1 D
GCL 8B 0 TABLE {I(V8)}=(-1,-1)(-0.04,0)(0.04,0)(1,1)
*
*supply current
GQ 9 7 VALUE={1MA+24*I(VOSFS)+(V(7)-V(9))/20K}
GCC 9 0 TABLE {I(V8)}=(-1,0)(0,0)(1,1)
GEE 7 0 TABLE {I(V8)}=(-1,-1)(0,0)(1,0)
*
.ENDS LT1251

```

## MACROMODEL

### LT1251/LT1256 Macro Model for PSpice

PIN # IN  NODE # IN

#### FIRST INPUT STAGE

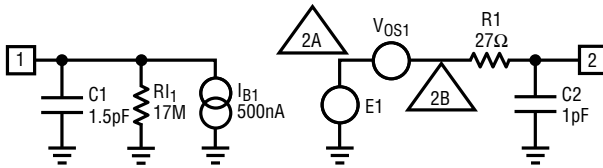

#### K GENERATOR

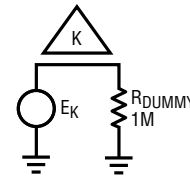

#### NOISE GENERATOR

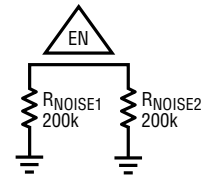

#### SECOND INPUT STAGE

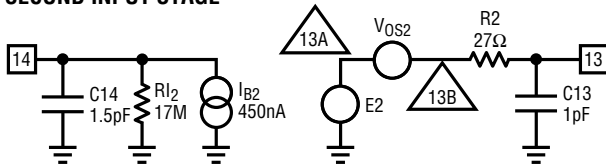

#### NULL CIRCUIT

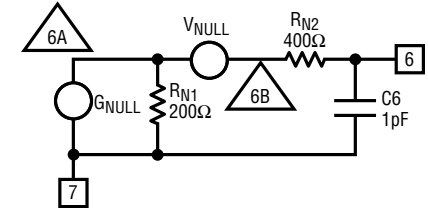

#### CONTROL AMP

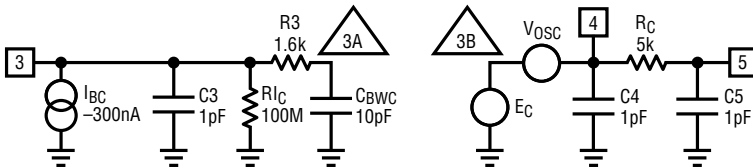

#### SUPPLY CURRENTS

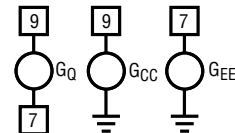

1251/56 MM

#### FULL SCALE AMP

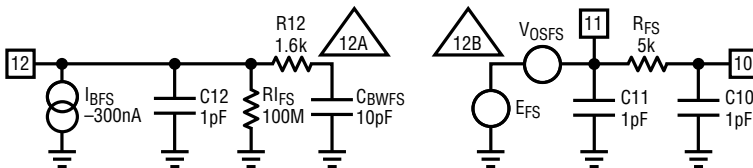

#### OUTPUT STAGE AND VOLTAGE SWING/CURRENT LIMIT

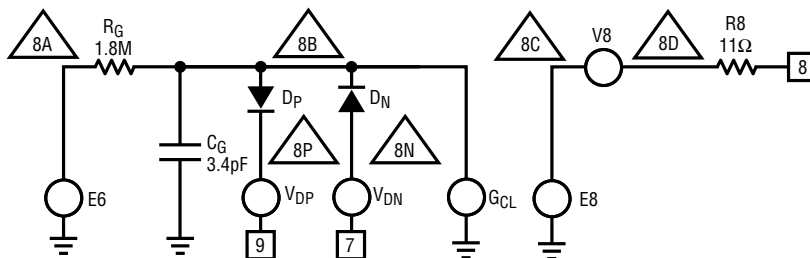

**PACKAGE DESCRIPTION**

Dimensions in inches (millimeters) unless otherwise noted.

**N Package**  
**14-Lead PDIP (Narrow 0.300)**  
 (LTC DWG # 05-08-1510)

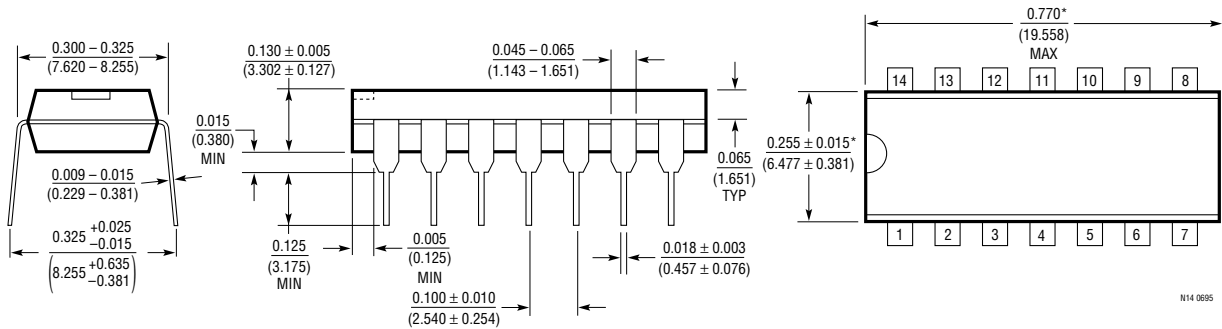

\*THESE DIMENSIONS DO NOT INCLUDE MOLD FLASH OR PROTRUSIONS.  
 MOLD FLASH OR PROTRUSIONS SHALL NOT EXCEED 0.010 INCH (0.254mm)

**S Package**  
**14-Lead Plastic Small Outline (Narrow 0.150)**  
 (LTC DWG # 05-08-1610)

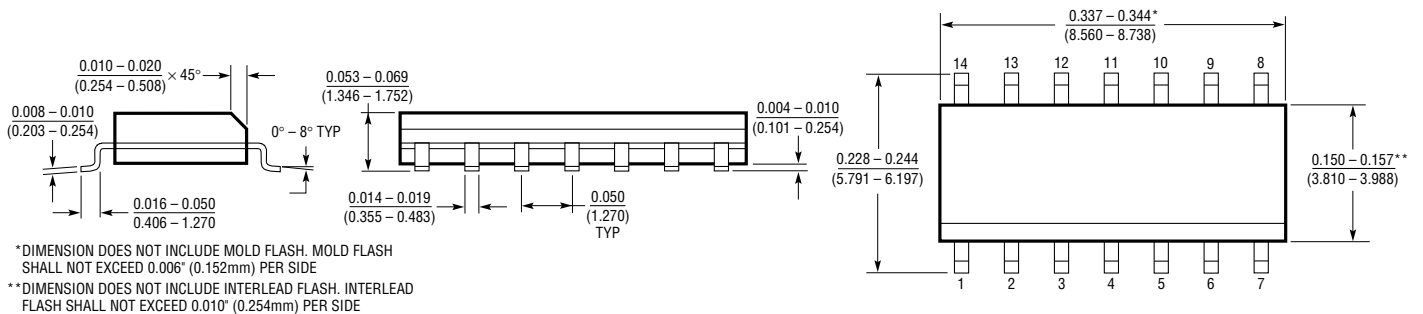

\*DIMENSION DOES NOT INCLUDE MOLD FLASH. MOLD FLASH SHALL NOT EXCEED 0.006" (0.152mm) PER SIDE

\*\*DIMENSION DOES NOT INCLUDE INTERLEAD FLASH. INTERLEAD FLASH SHALL NOT EXCEED 0.010" (0.254mm) PER SIDE

## TYPICAL APPLICATIONS

### 4-Quadrant Multiplier as a Double-Sideband Suppressed-Carrier Modulator

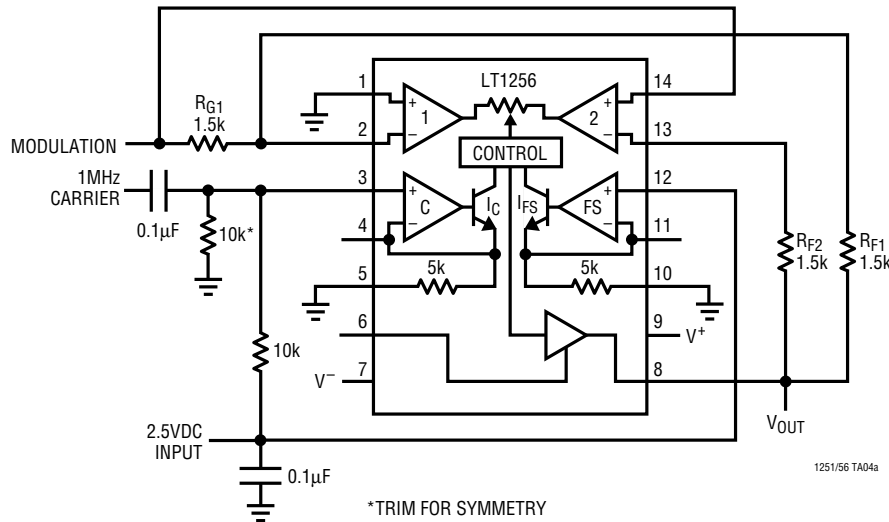

### Modulation Gain vs Control Voltage

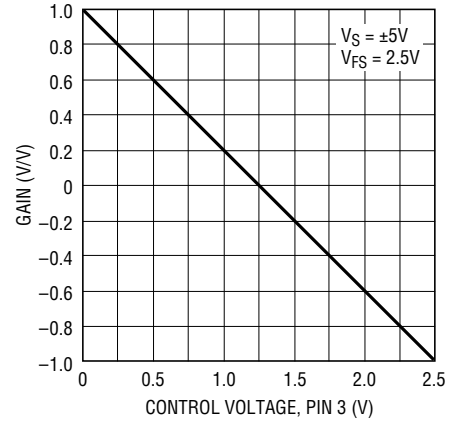

### Soft Clipper

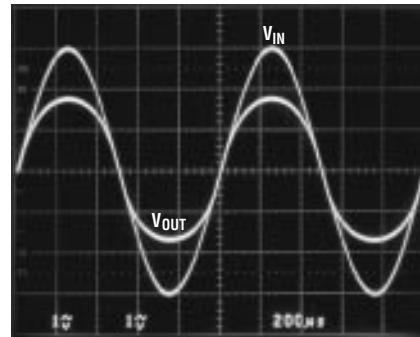
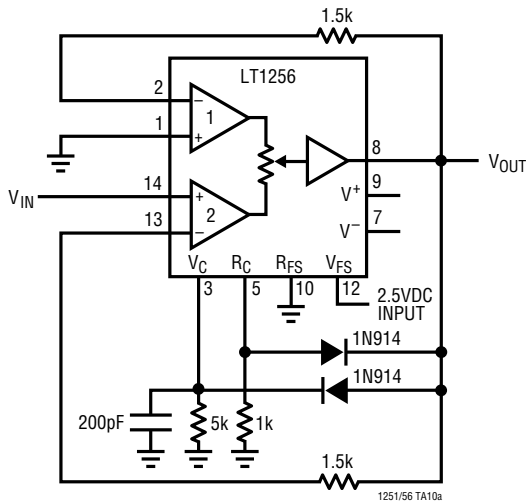

$V_{FS} = 2.5V$   
 $V_S = \pm 5V$   
 $f = 1kHz$

## RELATED PARTS

PART NUMBER	DESCRIPTION	COMMENTS
LT1228	100MHz Current Feedback Amplifier with DC Gain Control	Includes a 75MHz Transconductance Amplifier
LT1252	Low Cost Video Amplifier	100MHz Bandwidth
LT1253/LT1254	Low Cost Dual and Quad Video Amplifiers	90 MHz Bandwidth
LT1259/LT1260	Low Cost Dual and Triple 130MHz Current Feedback Amplifiers with Shutdown	Makes Fast Video MUX





## Стандарт Электрон Связь

Мы молодая и активно развивающаяся компания в области поставок электронных компонентов. Мы поставляем электронные компоненты отечественного и импортного производства напрямую от производителей и с крупнейших складов мира.

Благодаря сотрудничеству с мировыми поставщиками мы осуществляем комплексные и плановые поставки широчайшего спектра электронных компонентов.

Собственная эффективная логистика и склад в обеспечивает надежную поставку продукции в точно указанные сроки по всей России.

Мы осуществляем техническую поддержку нашим клиентам и предпродажную проверку качества продукции. На все поставляемые продукты мы предоставляем гарантию .

Осуществляем поставки продукции под контролем ВП МО РФ на предприятия военно-промышленного комплекса России , а также работаем в рамках 275 ФЗ с открытием отдельных счетов в уполномоченном банке. Система менеджмента качества компании соответствует требованиям ГОСТ ISO 9001.

Минимальные сроки поставки, гибкие цены, неограниченный ассортимент и индивидуальный подход к клиентам являются основой для выстраивания долгосрочного и эффективного сотрудничества с предприятиями радиоэлектронной промышленности, предприятиями ВПК и научно-исследовательскими институтами России.

С нами вы становитесь еще успешнее!

### Наши контакты:

**Телефон:** +7 812 627 14 35

**Электронная почта:** [sales@st-electron.ru](mailto:sales@st-electron.ru)

**Адрес:** 198099, Санкт-Петербург,  
Промышленная ул, дом № 19, литера Н,  
помещение 100-Н Офис 331