

CGHV60170D

170 W, 6.0 GHz, 50V GaN HEMT Die

Cree's CGHV60170D is a gallium nitride (GaN) High Electron Mobility Transistor (HEMT). GaN has superior properties compared to silicon or gallium arsenide, including higher breakdown voltage, higher saturated electron drift velocity, and higher thermal conductivity. GaN HEMTs offer greater power density and wider bandwidths compared to Si and GaAs transistors.

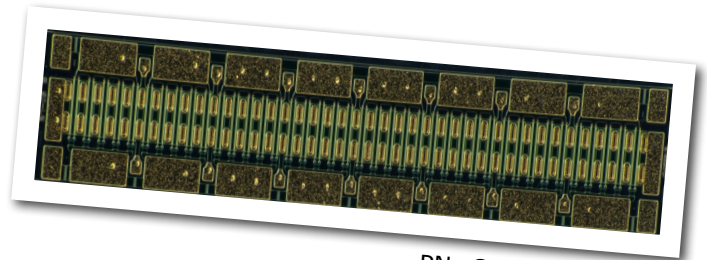

PN: CGHV60170D

FEATURES

- 18 dB Typical Small Signal Gain at 4 GHz
- 17 dB Typical Small Signal Gain at 6 GHz
- 65% Typical Power Added Efficiency
- 170 W Typical P_{SAT}
- 50 V Operation
- High Breakdown Voltage
- Up to 6 GHz Operation

APPLICATIONS

- Broadband amplifiers
- Tactical communications
- Satellite communications
- Industrial, Scientific, and Medical amplifiers
- Class AB, Linear amplifiers suitable for OFDM, W-CDMA, LTE, EDGE, CDMA waveforms

Packaging Information

- Bare die are shipped on tape or in Gel-Pak® containers.
- Non-adhesive tacky membrane immobilizes die during shipment.

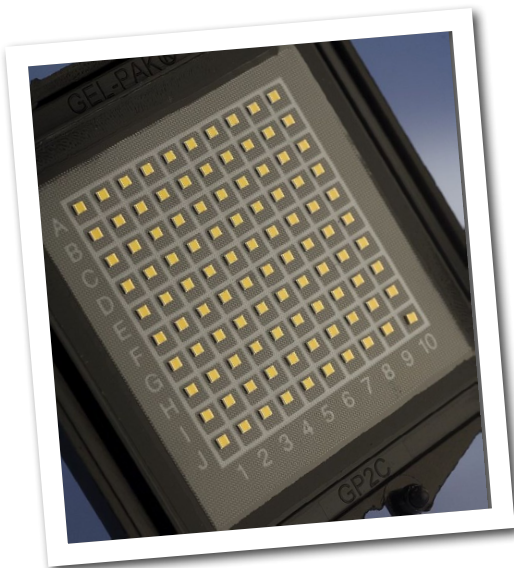

Absolute Maximum Ratings (not simultaneous)

Parameter	Symbol	Rating	Units	Conditions
Drain-source Voltage	V_{DSS}	150	V_{DC}	25 °C
Gate-source Voltage	V_{GS}	-10, +2	V_{DC}	25 °C
Storage Temperature	T_{STG}	-65, +150	°C	
Operating Junction Temperature	T_J	225	°C	
Maximum Drain Current ¹	I_{MAX}	12.6	A	25 °C
Maximum Forward Gate Current	I_{GMAX}	20.8	mA	25 °C
Thermal Resistance, Junction to Case (packaged) ²	$R_{\theta JC}$	1.36	°C/W	85 °C, 83.2W Dissipation
Thermal Resistance, Junction to Case (die only)	$R_{\theta JC}$	0.83	°C/W	85 °C, 83.2W Dissipation
Mounting Temperature	T_S	320	°C	30 seconds

Note¹ Current limit for long term reliable operation.

Note² Eutectic die attach using 80/20 AuSn mounted to a 10 mil thick Cu15Mo85 carrier.

Electrical Characteristics (Frequency = 6 GHz unless otherwise stated; $T_C = 25^\circ C$)

Characteristics	Symbol	Min.	Typ.	Max.	Units	Conditions
DC Characteristics						
Gate Pinch-Off Voltage	V_P	-3.8	-3.0	-2.3	V	$V_{DS} = 10 V, I_D = 20.8 mA$
Drain Current ¹	I_{DSS}	16.8	20.8	-	A	$V_{DS} = 6 V, V_{GS} = 2.0 V$
Drain-Source Breakdown Voltage	V_{BD}	150	-	-	V	$V_{GS} = -8 V, I_D = 20.8 mA$
On Resistance	R_{ON}	-	0.14	-	Ω	$V_{DS} = 0.1 V$
Gate Forward Voltage	V_{G-ON}	-	1.9	-	V	$I_{GS} = 20.8 mA$
RF Characteristics						
Small Signal Gain	G_{SS}	-	17	-	dB	$V_{DD} = 50 V, I_{DQ} = 260 mA$
Saturated Power Output ^{2,3}	P_{SAT}	-	170	-	W	$V_{DD} = 50 V, I_{DQ} = 260 mA$
Drain Efficiency ⁴	η	-	65	-	%	$V_{DD} = 50 V, I_{DQ} = 260 mA, P_{SAT} = 170 W$
Intermodulation Distortion	IM3	-	-30	-	dBc	$V_{DD} = 50 V, I_{DQ} = 260 mA, P_{OUT} = 170 W PEP$
Output Mismatch Stress	VSWR	-	-	10 : 1	Ψ	No damage at all phase angles, $V_{DD} = 50 V, I_{DQ} = 260 mA$ $P_{OUT} = 170 W CW$
Dynamic Characteristics						
Input Capacitance	C_{GS}	-	28.3	-	pF	$V_{DS} = 50 V, V_{GS} = -8 V, f = 1 MHz$
Output Capacitance	C_{DS}	-	6.35	-	pF	$V_{DS} = 50 V, V_{GS} = -8 V, f = 1 MHz$
Feedback Capacitance	C_{GD}	-	0.6	-	pF	$V_{DS} = 50 V, V_{GS} = -8 V, f = 1 MHz$

Notes:

¹ Scaled from PCM data

² P_{SAT} is defined as $I_G = 2.0 mA$.

³ Pulsed 100 μsec , 10%

⁴ Drain Efficiency = P_{OUT} / P_{DC}

DIE Dimensions (units in microns)

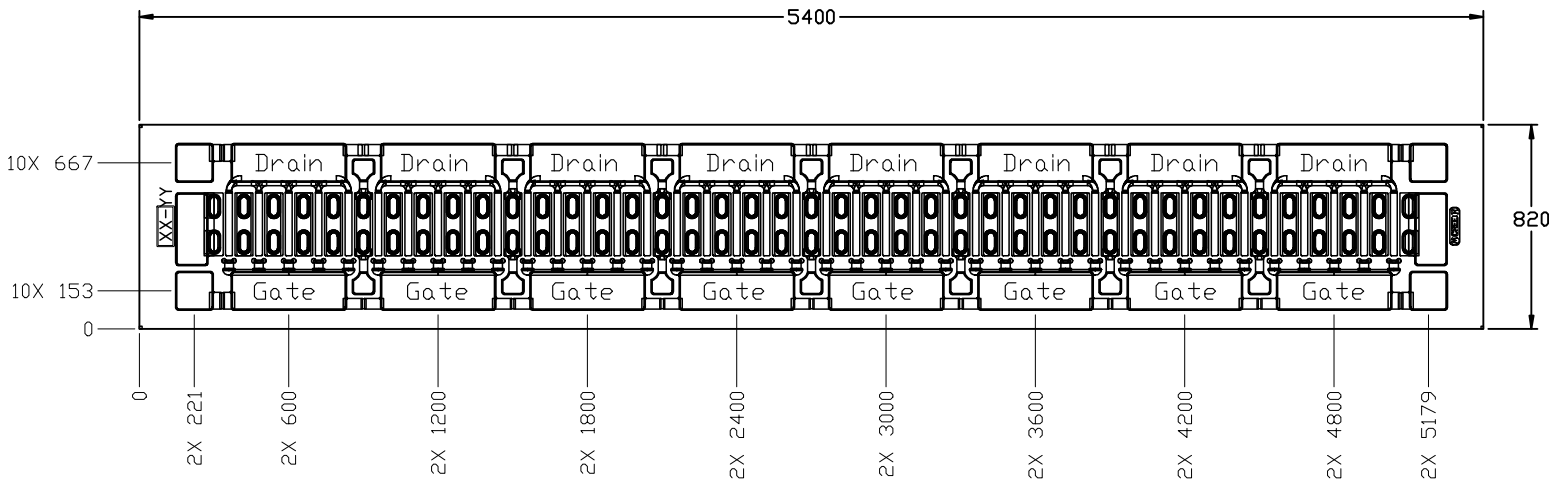

Overall die size 820 x 5400 (+0/-50) microns, die thickness 100 microns.
All Gate and Drain pads must be wire bonded for electrical connection.

Assembly Notes:

- Recommended solder is AuSn (80/20) solder. Refer to Cree's website for the Eutectic Die Bond Procedure application note at www.cree.com/RF.
- Vacuum collet is the preferred method of pick-up.
- The backside of the die is the Source (ground) contact.
- Die back side gold plating is 5 microns thick minimum.
- Thermosonic ball or wedge bonding are the preferred connection methods.
- Gold wire must be used for connections.
- Use the die label (XX-YY) for correct orientation.

Electrostatic Discharge (ESD) Classifications

Parameter	Symbol	Class	Test Methodology
Human Body Model	HBM	1A (> 250 V)	JEDEC JESD22 A114-D
Charge Device Model	CDM	2 (125 V to 250 V)	JEDEC JESD22 C101-C

Typical Performance

Figure 1. - CGHV60170D Output Power, Gain and Efficiency vs. Input Power at Tcase = 25°C
 $V_{DD} = 50\text{ V}$, $I_{DQ} = 260\text{ mA}$, Frequency = 2.7 GHz

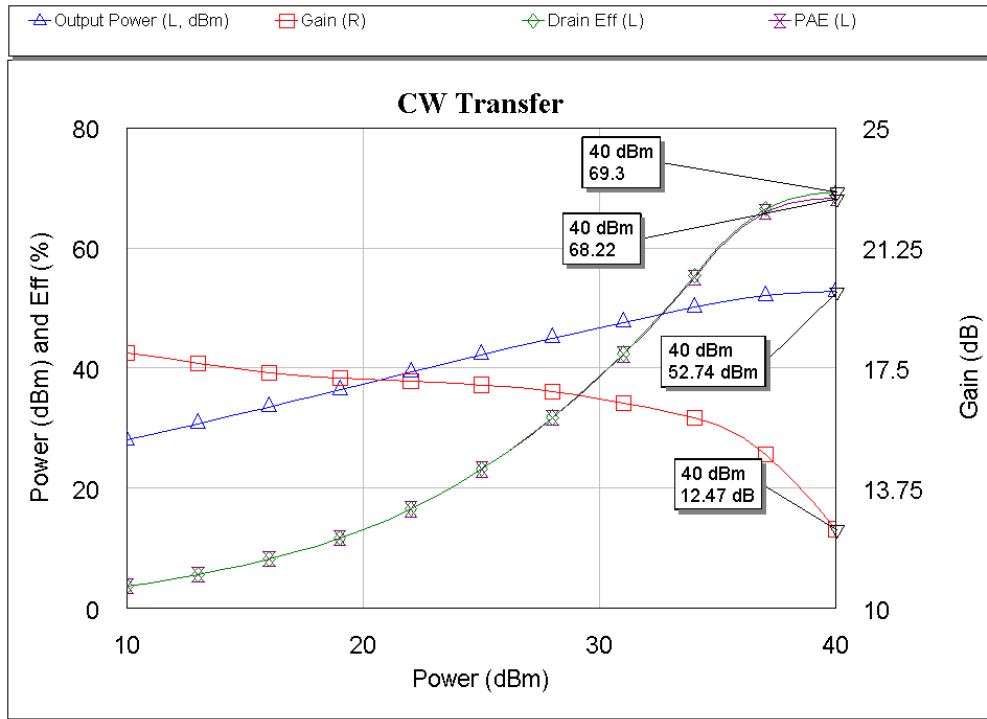
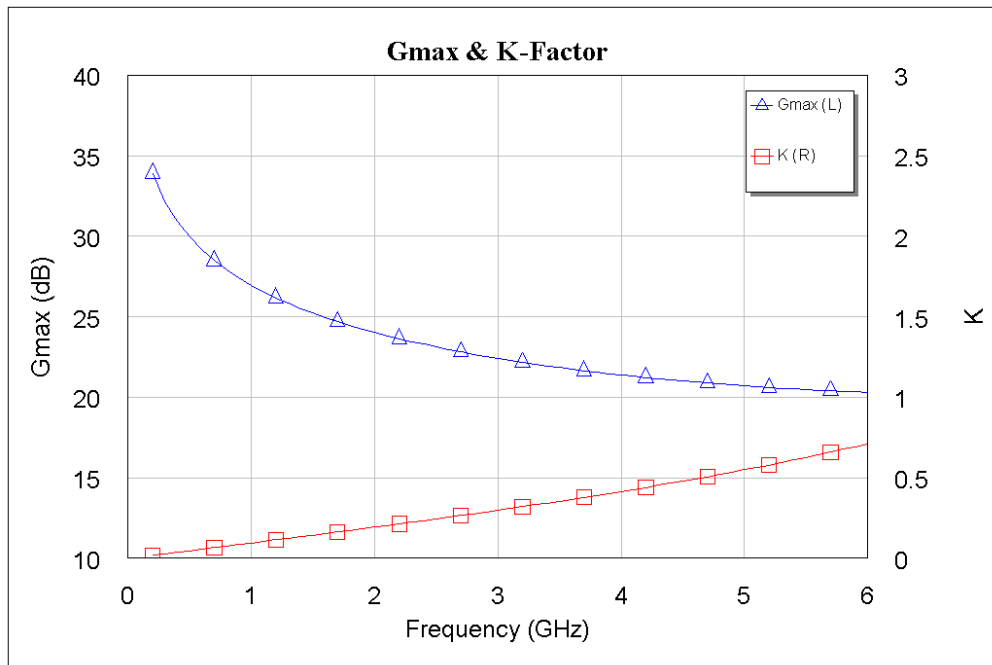

Figure 2. - CGHV60170D G_{MAX} and K Factor vs. Frequency at Tcase = 25°C
 $V_{DD} = 50\text{ V}$, $I_{DQ} = 260\text{ mA}$



Typical Die S-Parameters (Small Signal, $V_{DS} = 50\text{ V}$, $I_{DQ} = 260\text{ mA}$, magnitude / angle)

Frequency	Mag S11	Ang S11	Mag S21	Ang S21	Mag S12	Ang S12	Mag S22	Ang S22
0.5	0.943	-168.72	9.039	75.28	0.009	-13.64	0.544	-156.15
0.6	0.946	-170.27	7.375	70.86	0.009	-17.83	0.571	-155.58
0.7	0.948	-171.36	6.170	66.84	0.009	-21.63	0.600	-155.23
0.8	0.951	-172.18	5.255	63.13	0.009	-25.12	0.627	-155.11
0.9	0.953	-172.81	4.538	59.69	0.008	-28.34	0.654	-155.19
1	0.956	-173.33	3.961	56.48	0.008	-31.32	0.680	-155.45
1.1	0.959	-173.76	3.488	53.50	0.008	-34.08	0.704	-155.84
1.2	0.961	-174.13	3.095	50.72	0.008	-36.64	0.726	-156.32
1.3	0.963	-174.45	2.764	48.12	0.007	-39.02	0.747	-156.87
1.4	0.966	-174.73	2.482	45.69	0.007	-41.22	0.766	-157.45
1.5	0.968	-174.99	2.239	43.42	0.007	-43.27	0.783	-158.07
1.6	0.970	-175.23	2.030	41.30	0.007	-45.17	0.799	-158.69
1.7	0.971	-175.44	1.848	39.31	0.006	-46.94	0.814	-159.31
1.8	0.973	-175.64	1.688	37.44	0.006	-48.59	0.827	-159.93
1.9	0.974	-175.83	1.548	35.68	0.006	-50.12	0.839	-160.53
2	0.976	-176.00	1.424	34.02	0.006	-51.55	0.850	-161.11
2.1	0.977	-176.17	1.314	32.47	0.005	-52.88	0.860	-161.68
2.2	0.978	-176.32	1.216	31.00	0.005	-54.13	0.869	-162.23
2.3	0.979	-176.46	1.128	29.60	0.005	-55.30	0.877	-162.76
2.4	0.980	-176.60	1.049	28.29	0.005	-56.39	0.885	-163.27
2.5	0.981	-176.73	0.977	27.04	0.005	-57.41	0.892	-163.75
2.6	0.982	-176.85	0.913	25.85	0.005	-58.37	0.898	-164.22
2.7	0.983	-176.97	0.855	24.72	0.004	-59.27	0.904	-164.67
2.8	0.984	-177.08	0.802	23.65	0.004	-60.11	0.909	-165.09
2.9	0.984	-177.18	0.753	22.63	0.004	-60.91	0.914	-165.50
3	0.985	-177.29	0.709	21.65	0.004	-61.66	0.919	-165.90
3.2	0.986	-177.47	0.631	19.82	0.004	-63.03	0.927	-166.63
3.4	0.987	-177.65	0.566	18.13	0.004	-64.25	0.934	-167.31
3.6	0.988	-177.81	0.510	16.57	0.003	-65.34	0.940	-167.93
3.8	0.989	-177.95	0.462	15.12	0.003	-66.31	0.945	-168.50
4	0.989	-178.09	0.420	13.78	0.003	-67.19	0.950	-169.02
4.2	0.990	-178.22	0.384	12.51	0.003	-67.97	0.954	-169.51
4.4	0.991	-178.34	0.352	11.32	0.003	-68.67	0.958	-169.96
4.6	0.991	-178.45	0.324	10.20	0.003	-69.30	0.961	-170.38
4.8	0.991	-178.56	0.299	9.14	0.002	-69.86	0.964	-170.77
5	0.992	-178.66	0.277	8.13	0.002	-70.36	0.966	-171.14
5.2	0.992	-178.76	0.258	7.18	0.002	-70.81	0.968	-171.48
5.4	0.992	-178.85	0.240	6.26	0.002	-71.20	0.970	-171.80
5.6	0.993	-178.94	0.224	5.38	0.002	-71.55	0.972	-172.10
5.8	0.993	-179.02	0.210	4.54	0.002	-71.85	0.974	-172.38
6	0.993	-179.10	0.197	3.73	0.002	-72.10	0.975	-172.65

To download the s-parameters in s2p format, go to the [CGHV60170D Product Page](#) and click the documentation tab.

Part Number System

CGHV60170D

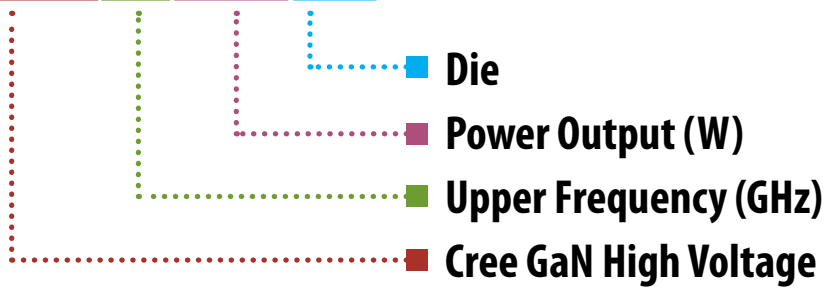

Parameter	Value	Units
Upper Frequency ¹	6.0	GHz
Power Output	170	W
Package	Bare Die	-

Table 1.

Note¹: Alpha characters used in frequency code indicate a value greater than 9.9 GHz. See Table 2 for value.

Character Code	Code Value
A	0
B	1
C	2
D	3
E	4
F	5
G	6
H	7
J	8
K	9
Examples:	1A = 10.0 GHz 2H = 27.0 GHz

Table 2.



Disclaimer

Specifications are subject to change without notice. Cree, Inc. believes the information contained within this data sheet to be accurate and reliable. However, no responsibility is assumed by Cree for its use or for any infringement of patents or other rights of third parties which may result from its use. No license is granted by implication or otherwise under any patent or patent rights of Cree. Cree makes no warranty, representation or guarantee regarding the suitability of its products for any particular purpose. "Typical" parameters are the average values expected by Cree in large quantities and are provided for information purposes only. These values can and do vary in different applications, and actual performance can vary over time. All operating parameters should be validated by customer's technical experts for each application. Cree products are not designed, intended, or authorized for use as components in applications intended for surgical implant into the body or to support or sustain life, in applications in which the failure of the Cree product could result in personal injury or death, or in applications for the planning, construction, maintenance or direct operation of a nuclear facility. CREE and the CREE logo are registered trademarks of Cree, Inc.

For more information, please contact:

Cree, Inc.
4600 Silicon Drive
Durham, NC 27703
www.cree.com/rf

Sarah Miller
Cree, Marketing & Export, RF Components
1.919.407.5302

Ryan Baker
Cree, Marketing, RF Components
1.919.407.7816

Tom Dekker
Cree, Sales Director, RF Components
1.919.407.5639



Стандарт Электрон Связь

Мы молодая и активно развивающаяся компания в области поставок электронных компонентов. Мы поставляем электронные компоненты отечественного и импортного производства напрямую от производителей и с крупнейших складов мира.

Благодаря сотрудничеству с мировыми поставщиками мы осуществляем комплексные и плановые поставки широчайшего спектра электронных компонентов.

Собственная эффективная логистика и склад в обеспечивает надежную поставку продукции в точно указанные сроки по всей России.

Мы осуществляем техническую поддержку нашим клиентам и предпродажную проверку качества продукции. На все поставляемые продукты мы предоставляем гарантию .

Осуществляем поставки продукции под контролем ВП МО РФ на предприятия военно-промышленного комплекса России , а также работаем в рамках 275 ФЗ с открытием отдельных счетов в уполномоченном банке. Система менеджмента качества компании соответствует требованиям ГОСТ ISO 9001.

Минимальные сроки поставки, гибкие цены, неограниченный ассортимент и индивидуальный подход к клиентам являются основой для выстраивания долгосрочного и эффективного сотрудничества с предприятиями радиоэлектронной промышленности, предприятиями ВПК и научно-исследовательскими институтами России.

С нами вы становитесь еще успешнее!

Наши контакты:

Телефон: +7 812 627 14 35

Электронная почта: sales@st-electron.ru

Адрес: 198099, Санкт-Петербург,
Промышленная ул, дом № 19, литера Н,
помещение 100-Н Офис 331