



# 3.3V, 3.2Gbps DIFFERENTIAL 4:1 LVDS MULTIPLEXER with INTERNAL INPUT TERMINATION

Precision Edge®  
SY89545L

## FEATURES

- Selects among four differential inputs
- Guaranteed AC performance over temp and voltage:
  - DC-to > 3.2Gbps data rate throughput
  - < 600ps In-to-Out  $t_{pd}$
  - < 150ps  $t_r/t_f$
- Ultra-low jitter design:
  - < 1ps<sub>RMS</sub> random jitter
  - < 10ps<sub>PP</sub> deterministic jitter
  - < 10ps<sub>PP</sub> total jitter (clock)
  - < 0.7ps<sub>RMS</sub> crosstalk-induced jitter
- Unique input isolation design minimizes crosstalk
- Internal input termination
- Unique input termination and  $V_T$  pin accepts DC-coupled and AC-coupled inputs (LVDS, LVPECL, CML)
- 350mV LVDS output swing
- CMOS/TTL compatible MUX select
- Power supply 3.3V +10%
- -40°C to +85°C temperature range
- Available in 32-pin (5mm x 5mm) MLF® package



Precision Edge®

## DESCRIPTION

The SY89545L is a fast, low jitter 4:1 differential MUX with an LVDS (350mV) compatible output with guaranteed data rate throughput of 3.2Gbps over temperature and voltage.

The SY89545L differential inputs include a unique, 3-pin internal termination that allows access to the termination network through a  $V_T$  pin. This feature allows the device to easily interface to different logic standards, both AC- and DC-coupled without external resistor-bias and termination networks. The result is a clean, stub-free, low jitter interface solution.

The SY89545L operates from a single 3.3V supply, and is guaranteed over the full industrial temperature range (-40°C to +85°C). For applications that require a 2.5V supply, consider the SY89544U. For applications that require two differential outputs, consider the SY89546U or SY89545L. The SY89545L is part of a Micrel's Precision Edge® product family. All support documentation can be found on Micrel's web site at [www.micrel.com](http://www.micrel.com).

## APPLICATIONS

- SONET/SDH channel select applications
- Fiber Channel multi-channel select applications
- Gigabit Ethernet multi-channel select

## TYPICAL PERFORMANCE

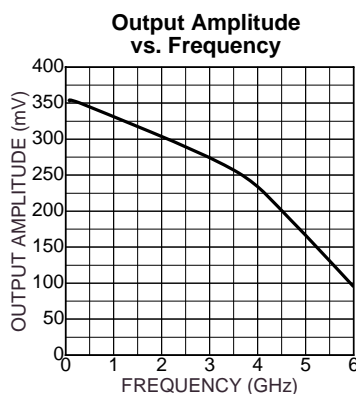

## FUNCTIONAL BLOCK DIAGRAM

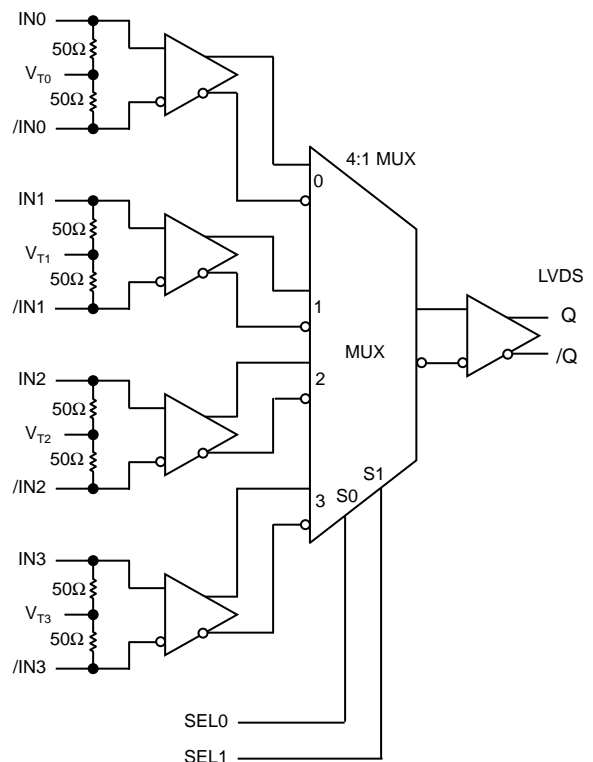

Precision Edge is a registered trademark of Micrel, Inc.  
MicroLeadFrame and MLF are registered trademarks of Amkor Technology, Inc.

**PACKAGE/ORDERING INFORMATION**

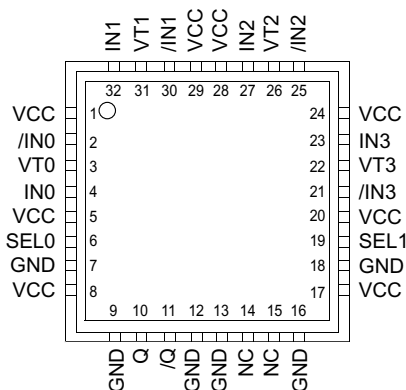

**32-Pin MLF®**

**Ordering Information<sup>(1)</sup>**

Part Number	Package Type	Operating Range	Package Marking	Lead Finish
SY89545LMI	MLF-32	Industrial	SY89545L	Sn-Pb
SY89545LMITR <sup>(2)</sup>	MLF-32	Industrial	SY89545L	Sn-Pb
SY89545LMG <sup>(3)</sup>	MLF-32	Industrial	SY89545L with Pb-Free bar-line indicator	Pb-Free NiPdAu
SY89545LMGTR <sup>(2, 3)</sup>	MLF-32	Industrial	SY89545L with Pb-Free bar-line indicator	Pb-Free NiPdAu

**Notes:**

1. Contact factory for die availability. Dice are guaranteed at  $T_A = 25^\circ\text{C}$ , DC electricals only.
2. Tape and Reel.
3. Recommended for new designs.

**PIN DESCRIPTION**

Pin Number	Pin Name	Pin Function
4, 2, 32, 30, 27, 25, 23, 21	IN0, /IN0, IN1, /IN1, IN2, /IN2, IN3, /IN3	Differential Inputs: These input pairs are the differential signal inputs to the device. Inputs accept AC- or DC-coupled signals as small as 100mV. Each pin of a pair internally terminates to a $V_T$ pin through $50\Omega$ . Note that these inputs will default to an indeterminate state if left open. Unused differential input pairs can be terminated by connecting one input to $V_{CC}$ and the complementary input to GND through a $1k\Omega$ resistor. The $V_T$ pin is to be left open in this configuration. Please refer to the "Input Interface Applications" section for more details.
3, 31, 26, 22	VT0, VT1, VT2, VT3	Input Termination Center-Tap: Each side of the differential input pair, terminates to a $V_T$ pin. The $V_{T0}$ , $V_{T1}$ , $V_{T2}$ , $V_{T3}$ pins provide a center-tap to a termination network for maximum interface flexibility. See "Input Interface Applications" section for more details.
6, 19	SEL0, SEL1	These single-ended TTL/CMOS compatible inputs select the inputs to the multiplexers. Note that these inputs are internally connected to a $25k\Omega$ pull-up resistor and will default to a logic HIGH state if left open.
1, 5, 8, 17, 20, 24, 28, 29	VCC	Positive Power Supply: Bypass with $0.1\mu\text{F}    0.01\mu\text{F}$ low ESR capacitors. The $0.01\mu\text{F}$ capacitor should be as close to $V_{CC}$ pin as possible.
10, 11	Q, /Q	Differential Outputs: This LVDS output pair is the output of the device. It is a logic function of the IN0, IN1, IN0, IN1 and SEL0 inputs. Please refer to the "Truth Table" for details.
7, 9, 12, 13, 16, 18	GND, Exposed pad	Ground: Ground pin and exposed pad must be connected to the same ground plane.
14, 15	NC	No connect. (Unused pins).

### Absolute Maximum Ratings<sup>(1)</sup>

Supply Voltage ( $V_{CC}$ ) .....	- 0.5V to + 4.0V
Input Voltage ( $V_{IN}$ ) .....	-0.5V to $V_{CC}$
Termination Current <sup>(3)</sup>	
Source or sink current on $V_T$ .....	$\pm 100$ mA
Input Current	
Source or sink current on IN, /IN .....	$\pm 50$ mA
Lead Temperature (soldering, 20 sec.) .....	+260°C
Storage Temperature (TS) .....	-65°C to +150°C

### Operating Ratings<sup>(2)</sup>

Supply Voltage ( $V_{CC}$ ) .....	3.0V to 3.6V
Ambient Temperature ( $T_A$ ) .....	-40°C to +85°C
Package Thermal Resistance <sup>(4)</sup>	
MLF® ( $\theta_{JA}$ )	
Still-Air .....	35°C/W
500lfpm .....	28°C/W
MLF® ( $\Psi_{JB}$ )	
Junction-to-Board .....	20°C/W

## DC ELECTRICAL CHARACTERISTICS<sup>(5)</sup>

$T_A = -40^\circ\text{C}$  to  $+85^\circ\text{C}$ ; Unless otherwise stated.

Symbol	Parameter	Condition	Min	Typ	Max	Units
$V_{CC}$	Power Supply		3.0	3.3	3.6	V
$I_{CC}$	Power Supply Current	No Load, Max. $V_{CC}$ <sup>(6)</sup>		44	60	mA
$R_{DIFF\_IN}$	Differential Input Resistance (IN-to-/IN)		80	100	120	$\Omega$
$R_{IN}$	Input Resistance (IN-to- $V_T$ , /IN-to- $V_T$ )		40	50	60	$\Omega$
$V_{IH}$	Input High Voltage (IN, /IN)		1.2		$V_{CC}$	V
$V_{IL}$	Input Low Voltage (IN, /IN)		0		$V_{IH}-0.1$	V
$V_{IN}$	Input Voltage Swing (IN, /IN)	<b>Notes 7</b>	0.1		$V_{CC}$	V
$V_{DIFF\_IN}$	Differential Input Voltage Swing   IN - /IN	<b>Notes 7</b>	0.2			V
IN-to- $V_T$	Voltage from Input to $V_T$				1.8	V

**Notes:**

1. Permanent device damage may occur if "Absolute Maximum Ratings" are exceeded. This is a stress rating only and functional operation is not implied at conditions other than those detailed in the operational sections of this data sheet. Exposure to "Absolute Maximum Ratings" conditions for extended periods may affect device reliability.
2. The data sheet limits are not guaranteed if the device is operated beyond the operating ratings.
3. Due to the limited drive capability use for input of the same package only.
4. Package thermal resistance assumes exposed pad is soldered (or equivalent) to the device's most negative potential on the PCB.  $\Psi_{JB}$  uses 4-layer  $\theta_{JA}$  in still air unless otherwise stated.
5. The circuit is designed to meet the DC specifications shown in the above table after thermal equilibrium has been established.
6. Includes current through internal 50 $\Omega$  pull-ups.
7. See "Operating Characteristics" section for  $V_{IN}$  and  $V_{DIFF\_IN}$  definition.

**LVDS OUTPUTS DC ELECTRICAL CHARACTERISTICS<sup>(9)</sup>**

$V_{CC} = 3.3V \pm 10\%$ ;  $T_A = -40^\circ\text{C}$  to  $+85^\circ\text{C}$ ;  $R_L = 100\Omega$  across Q and /Q, unless otherwise stated.

Symbol	Parameter	Condition	Min	Typ	Max	Units
$V_{OH}$	Output HIGH Voltage (Q, /Q)	See Figure 5a			1.475	V
$V_{OL}$	Output LOW Voltage (Q, /Q)	See Figure 5a	0.925			V
$V_{OUT}$	Output Voltage Swing (Q, /Q)	See Figures 1a, 5a	250	350		mV
$V_{DIFF-OUT}$	Differential Output Voltage Swing   Q - /Q	See Figure 1b	500	700		mV
$V_{OCM}$	Output Common Mode Voltage (Q, /Q)	See Figure 5b	1.125		1.275	V
$\Delta V_{OCM}$	Change in Common Mode Voltage (Q, /Q)	See Figure 5b	-50		+50	mV

**LVTTTL/CMOS DC ELECTRICAL CHARACTERISTICS<sup>(9)</sup>**

$V_{CC} = 3.3V \pm 10\%$ ;  $T_A = -40^\circ\text{C}$  to  $+85^\circ\text{C}$ ; unless otherwise stated.

Symbol	Parameter	Condition	Min	Typ	Max	Units
$V_{IH}$	Input HIGH Voltage		2.0		$V_{CC}$	V
$V_{IL}$	Input LOW Voltage				0.8	V
$I_{IH}$	Input HIGH Current				40	$\mu\text{A}$
$I_{IL}$	Input LOW Current				-300	$\mu\text{A}$

**Note:**

9. The circuit is designed to meet the DC specifications shown in the above table after thermal equilibrium has been established.

**AC ELECTRICAL CHARACTERISTICS<sup>(10)</sup>**

V<sub>CC</sub> = 3.3V ±10%; T<sub>A</sub> = -40°C to +85°C; R<sub>L</sub> = 100Ω across Q and /Q, unless otherwise stated.

Symbol	Parameter	Condition	Min	Typ	Max	Units
f <sub>MAX</sub>	Maximum Operating Frequency	NRZ Data	3.2			Gbps
		V <sub>OUT</sub> ≥ 200mV Clock		3		GHz
t <sub>pd</sub>	Differential Propagation Delay	IN-to-Q	400	500	600	ps
		SEL-to-Q	230	500	750	ps
t <sub>SKEW</sub>	Input-to-Input Skew	<b>Note 11</b>			25	ps
	Part-to-Part Skew	<b>Note 12</b>			200	ps
t <sub>JITTER</sub>	Data Random Jitter (RJ)	<b>Note 13</b>			1	ps <sub>RMS</sub>
	Deterministic Jitter (DJ)	<b>Note 14</b>			10	ps <sub>PP</sub>
	Clock Total Jitter (TJ)	<b>Note 15</b>			10	ps <sub>PP</sub>
	Cycle-to-Cycle Jitter	<b>Note 16</b>			1	ps <sub>RMS</sub>
	Crosstalk-Induced Jitter Adjacent Channel	<b>Note 17</b>			0.7	ps <sub>RMS</sub>
t <sub>R</sub> , t <sub>F</sub>	Output Rise / Fall Time (20% to 80%)	At full output swing	40	80	150	ps

**Notes:**

- 10. Measured with 100mV input swing. See "Timing Diagrams" section for definition of parameters. High frequency AC-parameters are guaranteed by design and characterization.
- 11. Input-to-input skew is the difference in propagation delay between any two inputs to the output under identical conditions.
- 12. Part-to-part skew is defined for two parts with identical power supply voltages at the same temperature and with no skew of the edges at the respective inputs.
- 13. RJ is measured with a K28.7 comma detect character pattern, measured at 1.25Gbps and 3.2Gbps.
- 14. DJ is measured at 1.25Gbps and 3.2Gbps, with both K28.5 and 2<sup>23</sup>-1 PRBS pattern.
- 15. Total jitter definition: with an ideal clock input of frequency ≤f<sub>MAX</sub>, no more than one output edge in 10<sup>12</sup> output edges will deviate by more than the specified peak-to-peak jitter value.
- 16. Cycle-to-cycle jitter definition: the variation of periods between adjacent cycles, T<sub>n</sub>-T<sub>n-1</sub> where T is the time between rising edges of the output signal.
- 17. Crosstalk is measured at the output while applying two similar frequencies to adjacent inputs that are asynchronous with respect to each other at the inputs.

**SINGLE-ENDED AND DIFFERENTIAL SWINGS**

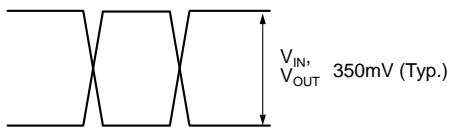

Figure 1a. Single-Ended Voltage Swing

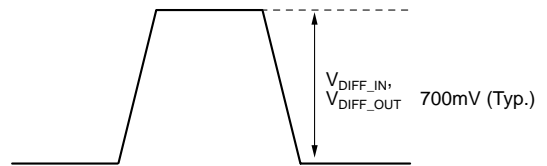

Figure 1b. Differential Voltage Swing

**TIMING DIAGRAM**

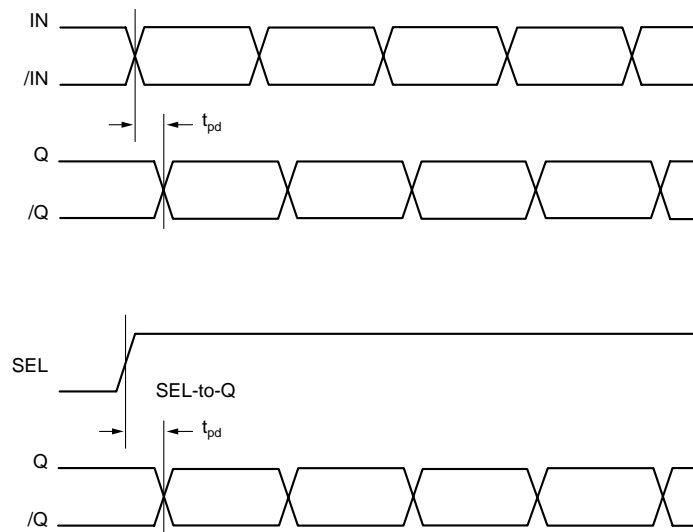

Figure 2. Timing Diagram

**TRUTH TABLE**

IN0	IN1	IN2	IN3	SEL0	SEL1	Q	/Q
0	X	X	X	0	0	0	1
1	X	X	X	0	0	1	0
X	0	X	X	1	0	0	1
X	1	X	X	1	0	1	0
X	X	0	X	0	1	0	1
X	X	1	X	0	1	1	0
X	X	X	0	1	1	0	1
X	X	X	1	1	1	1	0

**FUNCTIONAL CHARACTERISTICS**

**200MHz Output**

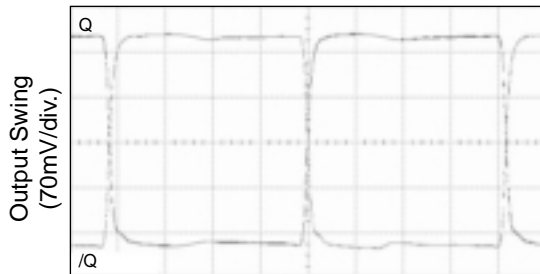

TIME (600ps/div.)

**1.6GHz Output**

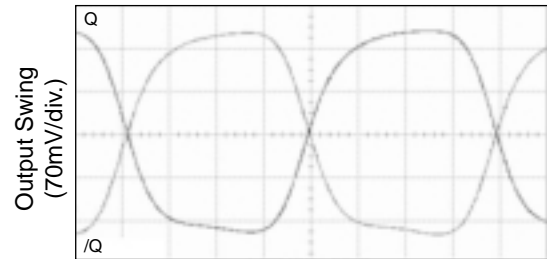

TIME (80ps/div.)

**2.5GHz Output**

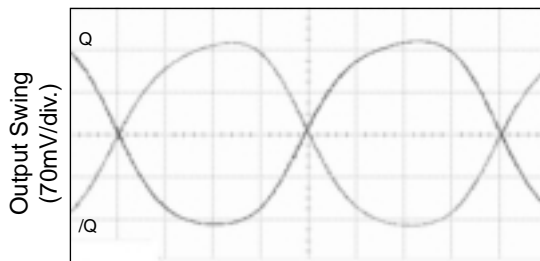

TIME (50ps/div.)

**3.2GHz Output**

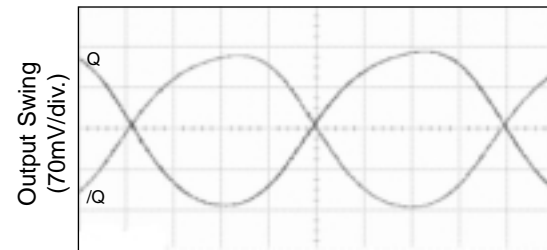

TIME (40ps/div.)

**622Mbps Eye Mask ( $2^{23}-1$  PRBS)**

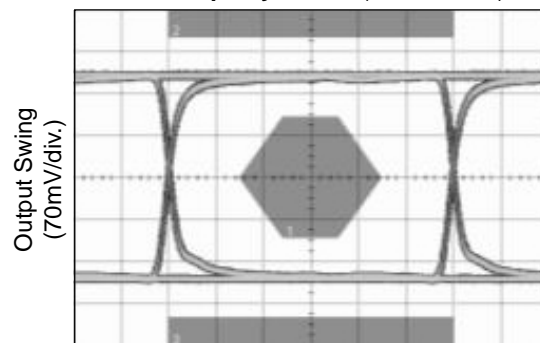

TIME (270ps/div.)

**2.5Gbps Output Eye ( $2^{23}-1$  PRBS)**

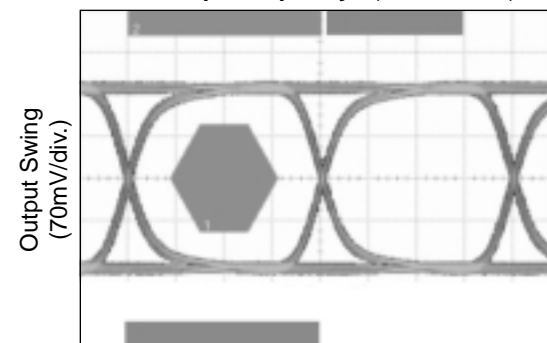

TIME (100ps/div.)

**3.2Gbps Eye Mask ( $2^{23}-1$  PRBS)**

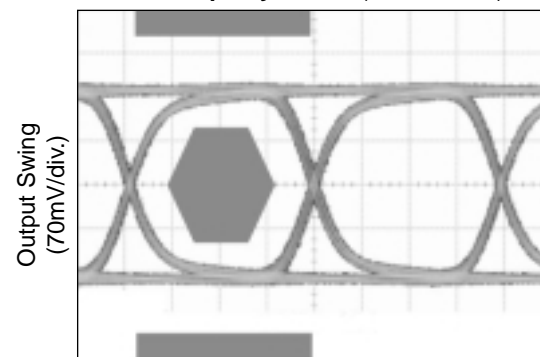

TIME (80ps/div.)

**INPUT AND OUTPUT STAGE INTERNAL TERMINATION**

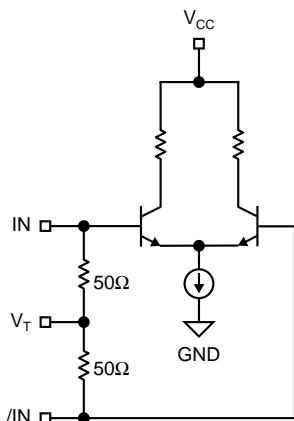

Figure 3. Simplified Differential Input Stage

**INPUT INTERFACE APPLICATIONS**

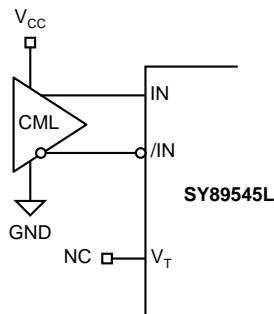

Figure 4a. CML Interface (DC-Coupled)

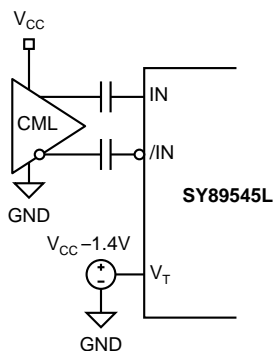
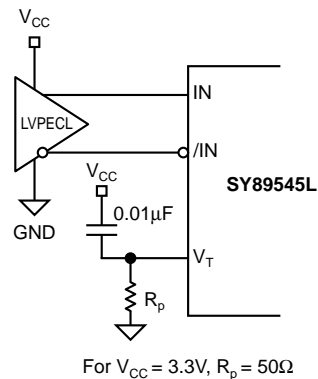
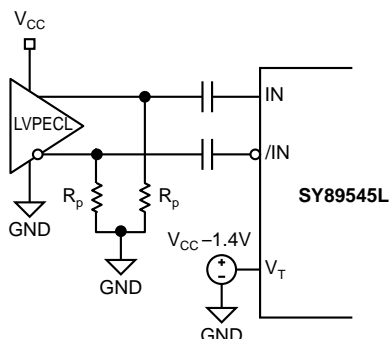

Figure 4b. CML Interface (AC-Coupled)



For  $V_{CC} = 3.3V$ ,  $R_p = 50\Omega$

Figure 4c. LVPECL Interface (DC-Coupled)



For  $V_{CC} = 3.3V$ ,  $R_p = 100\Omega$

Figure 4d. LVPECL Interface (AC-Coupled)

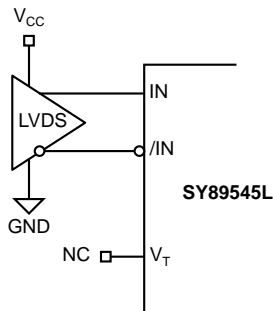

Figure 4e. LVDS Interface



**OUTPUT INTERFACE APPLICATIONS**

LVDS specifies a small swing of 350mV typical, on a nominal 1.25V common mode above ground. The common mode voltage has tight limits to permit large variations in

ground between an LVDS driver and receiver. Also, change in common mode voltage, as a function of data input, is kept to a minimum, to keep EMI low.

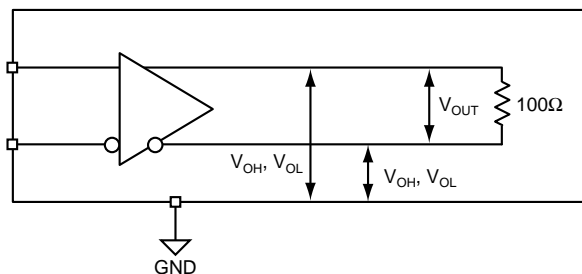

Figure 5a. LVDS Differential Measurement

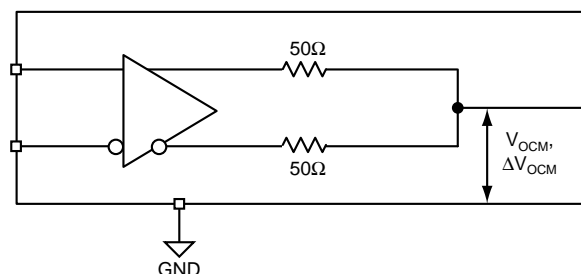
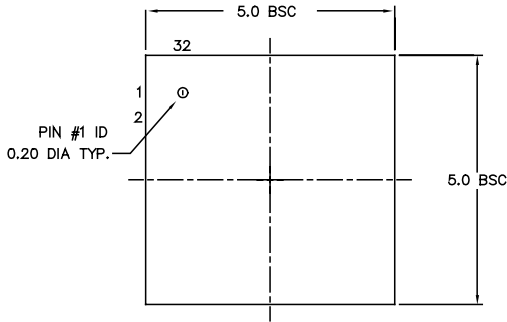

Figure 5b. LVDS Common Mode Measurement

**RELATED MICREL PRODUCTS AND SUPPORT DOCUMENTATION**

Part Number	Function	Data Sheet Link
SY89542U	2.5V, 3.2Gbps Dual, Differential 2:1 LVDS Multiplexer with Internal Input Termination	<a href="http://www.micrel.com/_PDF/HBW/sy89542u.pdf">http://www.micrel.com/_PDF/HBW/sy89542u.pdf</a>
SY89543L	3.3V, 3.2Gbps Dual, Differential 2:1 LVDS Multiplexer with Internal Input Termination	<a href="http://www.micrel.com/_PDF/HBW/sy89543l.pdf">http://www.micrel.com/_PDF/HBW/sy89543l.pdf</a>
SY89544U	2.5V, 3.2Gbps 4:1 LVDS Multiplexer with Internal Input Termination	<a href="http://www.micrel.com/_PDF/HBW/sy89544u.pdf">http://www.micrel.com/_PDF/HBW/sy89544u.pdf</a>
SY89546U	2.5V, 3.2Gbps, Differential 4:1 LVDS Multiplexer with 1:2 Fanout and Internal Input Termination	<a href="http://www.micrel.com/_PDF/HBW/sy89546u.pdf">http://www.micrel.com/_PDF/HBW/sy89546u.pdf</a>
SY89547L	3.3V, 3.2Gbps, Differential 4:1 LVDS Multiplexer with 1:2 Fanout and Internal Input Termination	<a href="http://www.micrel.com/_PDF/HBW/SY89547L.pdf">http://www.micrel.com/_PDF/HBW/SY89547L.pdf</a>
	MLF® Application Note	<a href="http://www.amkor.com/products/notes_papers/MLF_AppNote_0902.pdf">www.amkor.com/products/notes_papers/MLF_AppNote_0902.pdf</a>
HBW Solutions	New Products and Applications	<a href="http://www.micrel.com/product-info/products/solutions.shtml">www.micrel.com/product-info/products/solutions.shtml</a>

**32 LEAD MicroLeadFrame® (MLF-32)**



TOP VIEW

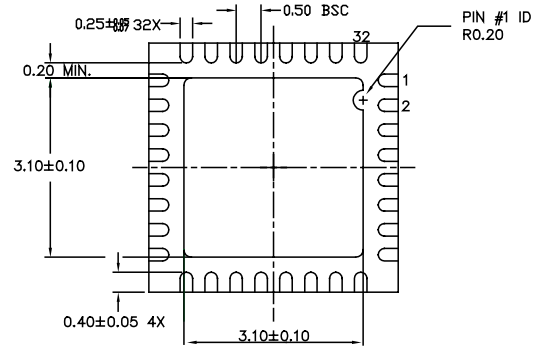

BOTTOM VIEW

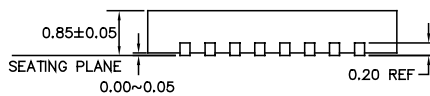

SIDE VIEW

- NOTE:
1. ALL DIMENSIONS ARE IN MILLIMETERS.
  2. MAX. PACKAGE WARPAGE IS 0.05 mm.
  3. MAXIMUM ALLOWABLE BURRS IS 0.076 mm IN ALL DIRECTIONS.
  4. PIN #1 ID ON TOP WILL BE LASER/INK MARKED.

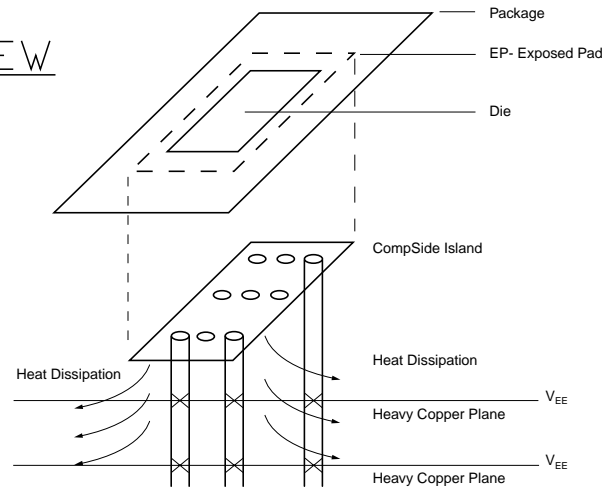

**PCB Thermal Consideration for 32-Pin MLF® Package  
(Always solder, or equivalent, the exposed pad to the PCB)**

**Package Notes:**

1. Package meets Level 2 qualification.
2. All parts are dry-packaged before shipment.
3. Exposed pads must be soldered to a ground for proper thermal management.

**MICREL, INC. 2180 FORTUNE DRIVE SAN JOSE, CA 95131 USA**

TEL + 1 (408) 944-0800 FAX + 1 (408) 474-1000 WEB <http://www.micrel.com>

The information furnished by Micrel in this data sheet is believed to be accurate and reliable. However, no responsibility is assumed by Micrel for its use. Micrel reserves the right to change circuitry and specifications at any time without notification to the customer.

Micrel Products are not designed or authorized for use as components in life support appliances, devices or systems where malfunction of a product can reasonably be expected to result in personal injury. Life support devices or systems are devices or systems that (a) are intended for surgical implant into the body or (b) support or sustain life, and whose failure to perform can be reasonably expected to result in a significant injury to the user. A Purchaser's use or sale of Micrel Products for use in life support appliances, devices or systems is at Purchaser's own risk and Purchaser agrees to fully indemnify Micrel for any damages resulting from such use or sale.

© 2005 Micrel, Incorporated.



## Стандарт Электрон Связь

Мы молодая и активно развивающаяся компания в области поставок электронных компонентов. Мы поставляем электронные компоненты отечественного и импортного производства напрямую от производителей и с крупнейших складов мира.

Благодаря сотрудничеству с мировыми поставщиками мы осуществляем комплексные и плановые поставки широчайшего спектра электронных компонентов.

Собственная эффективная логистика и склад в обеспечивает надежную поставку продукции в точно указанные сроки по всей России.

Мы осуществляем техническую поддержку нашим клиентам и предпродажную проверку качества продукции. На все поставляемые продукты мы предоставляем гарантию .

Осуществляем поставки продукции под контролем ВП МО РФ на предприятия военно-промышленного комплекса России , а также работаем в рамках 275 ФЗ с открытием отдельных счетов в уполномоченном банке. Система менеджмента качества компании соответствует требованиям ГОСТ ISO 9001.

Минимальные сроки поставки, гибкие цены, неограниченный ассортимент и индивидуальный подход к клиентам являются основой для выстраивания долгосрочного и эффективного сотрудничества с предприятиями радиоэлектронной промышленности, предприятиями ВПК и научно-исследовательскими институтами России.

С нами вы становитесь еще успешнее!

### Наши контакты:

**Телефон:** +7 812 627 14 35

**Электронная почта:** [sales@st-electron.ru](mailto:sales@st-electron.ru)

**Адрес:** 198099, Санкт-Петербург,  
Промышленная ул, дом № 19, литера Н,  
помещение 100-Н Офис 331