



SLRC610

High-performance ICODE frontend SLRC610 and SLRC610 *plus*

Rev. 4.7 — 26 February 2020
227647

Product data sheet
COMPANY PUBLIC

1 General description

SLRC610, the low-cost RFID frontend.

The SLRC610 multi-protocol NFC frontend IC supports the following operating modes:

- Read/write mode supporting ISO/IEC 15693
- Read/write mode supporting ICODE EPC UID/ EPC OTP
- Read/write mode supporting ISO/IEC 18000-3 mode 3/ EPC Class-1 HF

The SLRC610 supports the vicinity protocol according to ISO/IEC15693, EPC UID and ISO/IEC 18000-3 mode 3/ EPC Class-1 HF.

The following host interfaces are supported:

- Serial Peripheral Interface (SPI)
- Serial UART (similar to RS232 with voltage levels dependent on pin voltage supply)
- I²C-bus interface (two versions are implemented: I2C and I2CL)

The SLRC610 supports the connection of a secure access module (SAM). A dedicated separate I²C interface is implemented for a connection of the SAM. The SAM can be used for high secure key storage and acts as a very performant crypto coprocessor. A dedicated SAM is available for connection to the SLRC610.



2 Features and benefits

- RFID frontend
- Supports ISO/IEC15693, ICODE EPC UID and ISO/IEC 18000-3 mode 3/ EPC Class-1 HF
- Low-power card detection
- Antenna connection with minimum number of external components
- Supported host interfaces:
 - SPI up to 10 Mbit/s
 - I²C-bus interfaces up to 400 kBd in Fast mode, up to 1000 kBd in Fast mode plus
 - RS232 Serial UART up to 1228.8 kBd, with voltage levels dependent on pin voltage supply
- Separate I²C-bus interface for connection of a secure access module (SAM)
- FIFO buffer with size of 512 byte for highest transaction performance
- Flexible and efficient power saving modes including hard power down, standby and low-power card detection
- Cost saving by integrated PLL to derive system clock from 27.12 MHz RF quartz crystal
- 3 V to 5.5 V power supply (SLRC61002)
2.5 V to 5.5 V power supply (SLRC61003)
- Up to 8 free programmable input/output pins
- The version SLRC61003 offers a more flexible configuration for Low-Power Card detection compared to the SLRC6102 with the new register LPCD_OPTIONS. In addition, the SLRC61003 offers new additional settings for the Load Protocol which fit very well to smaller antennas. The SLRC61003 is therefore the recommended version for new designs

3 Applications

- Industrial
- Access control
- Gaming

4 Quick reference data

Table 1. Quick reference data SLRC61002HN

Symbol	Parameter	Conditions		Min	Typ	Max	Unit
V _{DD}	supply voltage			3.0	5.0	5.5	V
V _{DD(PVDD)}	PVDD supply voltage		[1]	3.0	5.0	V _{DD}	V
V _{DD(TVDD)}	TVDD supply voltage			3.0	5.0	5.5	V
I _{pd}	power-down current	PDOWN pin pulled HIGH	[2]	-	8	40	nA
I _{DD}	supply current			-	17	20	mA
I _{DD(TVDD)}	TVDD supply current			-	100	250	mA
T _{amb}	operating ambient temperature			-25	+25	+85	°C
T _{stg}	storage temperature	no supply voltage applied		-55	+25	+125	°C

[1] V_{DD}(PVDD) must always be the same or lower voltage than V_{DD}.

[2] I_{pd} is the sum of all supply currents

Table 2. Quick reference data SLRC61003HN

Symbol	Parameter	Conditions		Min	Typ	Max	Unit
V _{DD}	supply voltage			2.5	5.0	5.5	V
V _{DD(PVDD)}	PVDD supply voltage		[1]	2.5	5.0	V _{DD}	V
V _{DD(TVDD)}	TVDD supply voltage			2.5	5.0	5.5	V
I _{pd}	power-down current	PDOWN pin pulled HIGH	[2]	-	8	40	nA
I _{DD}	supply current			-	17	20	mA
I _{DD(TVDD)}	TVDD supply current			-	180	350	mA
		absolute limiting value		-	-	500	mA
T _{amb}	operating ambient temperature	device mounted on PCB which allows sufficient heat dissipation		-40	+25	+105	°C
T _{stg}	storage temperature	no supply voltage applied		-55	+25	+125	°C

[1] V_{DD}(PVDD) must always be the same or lower voltage than V_{DD}.

[2] I_{pd} is the sum of all supply currents

5 Ordering information

Table 3. Ordering information

Type number	Package		Version
	Name	Description	
SLRC61002HN/TRAYB ^[1]	HVQFN32	plastic thermal enhanced very thin quad flat package; no leads; MSL1, 32 terminals + 1 central ground; body 5 × 5 × 0.85 mm	SOT617-1
SLRC61002HN/TRAYBM ^[2]			
SLRC61002HN/T/R ^[3]			
SLRC61003HN/TRAYB ^[4]		plastic thermal enhanced very thin quad flat package; no leads; MSL2, 32 terminals + 1 central ground; body 5 × 5 × 0.85 mm, wettable flanks	
SLRC61003HN/T/R ^[5]			

[1] Delivered in one tray

[2] Delivered in five trays

[3] Delivered on reel with 6000 pieces

[4] Delivered in one tray, MOQ (Minimum order quantity) : 490 pcs

[5] Delivered on reel with 6000 pieces; MOQ (Minimum order quantity) : 6000 pcs

6 Block diagram

The analog interface handles the modulation and demodulation of the antenna signals for the contactless interface.

The contactless UART manages the protocol dependency of the contactless interface settings managed by the host.

The FIFO buffer ensures fast and convenient data transfer between host and the contactless UART.

The register bank contains the settings for the analog and digital functionality.



Figure 1. Simplified block diagram of the SLRC610

7 Pinning information



7.1 Pin description

Table 4. Pin description

Pin	Symbol	Type	Description
1	TDO / OUT0	O	test data output for boundary scan interface / general purpose output 0
2	TDI / OUT1	I	test data input boundary scan interface / general purpose output 1
3	TMS / OUT2	I	test mode select boundary scan interface / general purpose output 2
4	TCK / OUT3	I	test clock boundary scan interface / general purpose output 3
5	SIGIN /OUT7	I/O	Contactless communication interface output. / general purpose output 7
6	SIGOUT	O	Contactless communication interface input.
7	DVDD	PWR	digital power supply buffer ^[1]
8	VDD	PWR	power supply
9	AVDD	PWR	analog power supply buffer ^[1]
10	AUX1	O	auxiliary outputs: Pin is used for analog test signal
11	AUX2	O	auxiliary outputs: Pin is used for analog test signal
12	RXP	I	receiver input pin for the received RF signal.
13	RXN	I	receiver input pin for the received RF signal.
14	VMID	PWR	internal receiver reference voltage ^[1]
15	TX2	O	transmitter 2: delivers the modulated 13.56 MHz carrier
16	TVSS	PWR	transmitter ground, supplies the output stage of TX1, TX2
17	TX1	O	transmitter 1: delivers the modulated 13.56 MHz carrier

Pin	Symbol	Type	Description
18	TVDD	PWR	transmitter voltage supply
19	XTAL1	I	crystal oscillator input: Input to the inverting amplifier of the oscillator. This pin is also the input for an externally generated clock (fosc = 27.12 MHz)
20	XTAL2	O	crystal oscillator output: output of the inverting amplifier of the oscillator
21	PDOWN	I	Power Down (RESET)
22	CLKOUT / OUT6	O	clock output / general purpose output 6
23	SCL	O	Serial Clock line
24	SDA	I/O	Serial Data Line
25	PVDD	PWR	pad power supply
26	IFSEL0 / OUT4	I	host interface selection 0 / general purpose output 4
27	IFSEL1 / OUT5	I	host interface selection 1 / general purpose output 5
28	IF0	I/O	interface pin, multifunction pin: Can be assigned to host interface RS232, SPI, I ² C, I ² C-L
29	IF1	I/O	interface pin, multifunction pin: Can be assigned to host interface SPI, I ² C, I ² C-L
30	IF2	I/O	interface pin, multifunction pin: Can be assigned to host interface RS232, SPI, I ² C, I ² C-L
31	IF3	I/O	interface pin, multifunction pin: Can be assigned to host interface RS232, SPI, I ² C, I ² C-L
32	IRQ	O	interrupt request: output to signal an interrupt event
33	VSS	PWR	ground and heat sink connection

[1] This pin is used for connection of a buffer capacitor. Connection of a supply voltage might damage the device.

8 Functional description



Figure 3. Detailed block diagram of the SLRC610

8.1 Interrupt controller

The interrupt controller handles the enabling/disabling of interrupt requests. All of the interrupts can be configured by firmware. Additionally, the firmware has possibilities to trigger interrupts or clear pending interrupt requests. Two 8-bit interrupt registers IRQ0 and IRQ1 are implemented, accompanied by two 8-bit interrupt enable registers IRQ0En and IRQ1En. A dedicated functionality of bit 7 to set and clear bits 0 to 6 in this interrupt controller registers is implemented.

The SLRC610 indicates certain events by setting bit IRQ in the register Status1Reg and additionally, if activated, by pin IRQ. The signal on pin IRQ may be used to interrupt the host using its interrupt handling capabilities. This allows the implementation of efficient host software.

Table 4. shows the available interrupt bits, the corresponding source and the condition for its activation. The interrupt bits Timer0IRQ, Timer1IRQ, Timer2IRQ, Timer3OIRQ, in register IRQ1 indicate an interrupt set by the timer unit. The setting is done if the timer underflows.

The TxIRQ bit in register IRQ0 indicates that the transmission is finished. If the state changes from sending data to transmitting the end of the frame pattern, the transmitter unit sets the interrupt bit automatically.

The bit RxIRQ in register IRQ0 indicates an interrupt when the end of the received data is detected.

The bit IdleIRQ in register IRQ0 is set if a command finishes and the content of the command register changes to idle.

The register WaterLevel defines both - minimum and maximum warning levels - counting from top and from bottom of the FIFO by a single value.

The bit HiAlertIRQ in register IRQ0 is set to logic 1 if the HiAlert bit is set to logic 1, that means the FIFO data number has reached the top level as configured by the register WaterLevel and bit WaterLevelExtBit.

The bit LoAlertIRQ in register IRQ0 is set to logic 1 if the LoAlert bit is set to logic 1, that means the FIFO data number has reached the bottom level as configured by the register WaterLevel.

The bit ErrIRQ in register IRQ0 indicates an error detected by the contactless UART during receive. This is indicated by any bit set to logic 1 in register Error.

The bit LPCDIRQ in register IRQ0 indicates a card detected.

The bit RxSOFIRQ in register IRQ0 indicates a detection of a SOF or a subcarrier by the contactless UART during receiving.

The bit GlobalIRQ in register IRQ1 indicates an interrupt occurring at any other interrupt source when enabled.

Table 5. Interrupt sources

Interrupt bit	Interrupt source	Is set automatically, when
Timer0IRQ	Timer Unit	the timer register T0 CounterVal underflows
Timer1IRQ	Timer Unit	the timer register T1 CounterVal underflows
Timer2IRQ	Timer Unit	the timer register T2 CounterVal underflows
Timer3IRQ	Timer Unit	the timer register T3 CounterVal underflows
TxIRQ	Transmitter	a transmitted data stream ends
RxIRQ	Receiver	a received data stream ends
IdleIRQ	Command Register	a command execution finishes
HiAlertIRQ	FIFO-buffer pointer	the FIFO data number has reached the top level as configured by the register WaterLevel
LoAlertIRQ	FIFO-buffer pointer	the FIFO data number has reached the bottom level as configured by the register WaterLevel
ErrIRQ	contactless UART	a communication error had been detected
LPCDIRQ	LPCD	a card was detected when in low-power card detection mode
RxSOFIRQ	Receiver	detection of a SOF or a subcarrier
GlobalIRQ	all interrupt sources	will be set if another interrupt request source is set

8.2 Timer module

Timer module overview

The SLRC610 implements five timers. Four timers -Timer0 to Timer3 - have an input clock that can be configured by register T(x)Control to be 13.56 MHz, 212 kHz, (derived from the 27.12 MHz quartz) or to be the underflow event of the fifth Timer (Timer4). Each timer implements a counter register which is 16 bit wide. A reload value for the counter is defined in a range of 0000h to FFFFh in the registers TxReloadHi and TxReloadLo. The fifth timer Timer4 is intended to be used as a wakeup timer and is connected to the internal LFO (Low Frequency Oscillator) as input clock source.

The TControl register allows the global start and stop of each of the four timers Timer0 to Timer3. Additionally, this register indicates if one of the timers is running or stopped. Each of the five timers implements an individual configuration register set defining timer reload value (e.g. T0ReloadHi,T0ReloadLo), the timer value (e.g. T0CounterValHi, T0CounterValLo) and the conditions which define start, stop and clockfrequency (e.g. T0Control).

The external host may use these timers to manage timing relevant tasks. The timer unit may be used in one of the following configurations:

- Time-out counter
- Watch-dog counter
- Stop watch
- Programmable one-shot timer
- Periodical trigger

The timer unit can be used to measure the time interval between two events or to indicate that a specific event has occurred after an elapsed time. The timer register content is modified by the timer unit, which can be used to generate an interrupt to allow an host to react on this event.

The counter value of the timer is available in the registers T(x)CounterValHi, T(x)CounterValLo. The content of these registers is decremented at each timer clock.

If the counter value has reached a value of 0000h and the interrupts are enabled for this specific timer, an interrupt will be generated as soon as the next clock is received.

If enabled, the timer event can be indicated on the pin IRQ (interrupt request). The bit Timer(x)IRQ can be set and reset by the host controller. Depending on the configuration, the timer will stop counting at 0000h or restart with the value loaded from registers T(x)ReloadHi, T(x)ReloadLo.

The counting of the timer is indicated by bit TControl.T(x)Running.

The timer can be started by setting bits TControl.T(x)Running and TControl.T(x)StartStopNow or stopped by setting the bits TControl.T(x)StartStopNow and clearing TControl.T(x)Running.

Another possibility to start the timer is to set the bit T(x)Mode.T(x)Start, this can be useful if dedicated protocol requirements need to be fulfilled.

8.2.1 Timer modes

8.2.1.1 Time-Out- and Watch-Dog-Counter

Having configured the timer by setting *register* $T(x)ReloadValue$ and starting the counting of Timer(x) by setting bit TControl.T(x)StartStop and TControl.T(x)Running, the timer unit decrements the $T(x)CounterValue$ Register beginning with the configured start event. If the configured stop event occurs before the Timer(x) underflows (e.g. a bit is received from the card), the timer unit stops (no interrupt is generated).

If no stop event occurs, the timer unit continues to decrement the counter registers until the content is zero and generates a timer interrupt request at the next clock cycle. This allows to indicate to a host that the event did not occur during the configured time interval.

8.2.1.2 Wake-up timer

The wake-up Timer4 allows to wakeup the system from standby after a predefined time. The system can be configured in such a way that it is entering the standby mode again in case no card had been detected.

This functionality can be used to implement a low-power card detection (LPCD). For the low-power card detection it is recommended to set T4Control.T4AutoWakeUp and T4Control.T4AutoRestart, to activate the Timer4 and automatically set the system in standby. The internal low frequency oscillator (LFO) is then used as input clock for this Timer4. If a card is detected the host-communication can be started. If bit T4Control.T4AutoWakeUp is not set, the SLRC610 will not enter the standby mode again in case no card is detected but stays fully powered.

8.2.1.3 Stop watch

If an underflow occurred which can be identified by evaluating the corresponding IRQ bit, the performed time measurement according to the formula above is not correct.

The elapsed time between a configured start- and stop event may be measured by the CLRC663 timer unit. By setting the registers $T(x)ReloadValueHi$, $T(x)reloadValueLo$ the timer starts to decrement as soon as activated. If the configured stop event occurs, the timer stops decrementing. The elapsed time between start and stop event can then be calculated by the host dependent on the timer interval TTimer:

$$\Delta T = (T_{reload_value} - T_{timer_value}) * T_{Timer} \quad (1)$$

If an underflow occurred which can be identified by evaluating the corresponding IRQ bit, the performed time measurement according to the formula above is not correct.

8.2.1.4 Programmable one-shot timer

The host configures the interrupt and the timer, starts the timer and waits for the interrupt event on pin IRQ. After the configured time the interrupt request will be raised.

8.2.1.5 Periodical trigger

If the bit $T(x)Control.T(x)AutoRestart$ is set and the interrupt is activated, an interrupt request will be indicated periodically after every elapsed timer period.

8.3 Contactless interface unit

The contactless interface unit of the SLRC610 supports the following read/write operating modes:

- ISO/IEC15693/ICODE
- ICODE EPC UID
- ISO/IEC 18000-3 mode 3/ EPC Class-1 HF

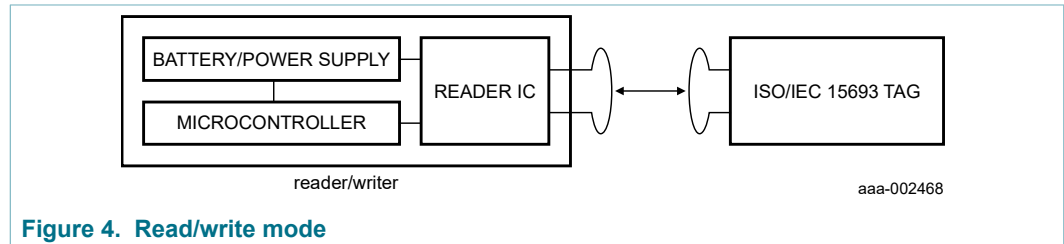

A typical system using the SLRC610 is using a microcontroller to implement the higher levels of the contactless communication protocol and a power supply (battery or external supply).

8.3.1 ISO/IEC15693 functionality

The physical parameters are described in [Table 5](#).

Table 6. Communication overview for ISO/IEC 15693 reader/writer reader to label

Communication direction	Signal type	Transfer speed	
		fc / 8192 kbit/s	fc / 512 kbit/s
Reader to label (send data from the SLRC610 to a card)	reader side modulation	10 % to 30 % ASK or 100 % ASK	10 % to 30 % ASK 90 % to 100 % ASK
	bit encoding	1/256	1/4
	data rate	1,66 kbit/s	26,48kbit/s

Table 7. Communication overview for ISO/IEC 15693 reader/writer label to reader

Communication direction	Signal type	Transfer speed			
		6.62 (6.67) kbit/s	13.24 kbit/s ^[1]	26.48 (26.69) kbit/s	52.96 kbit/s
Label to reader (SLRC610 receives data from a card) fc = 13.56 MHz	card side modulation	not supported	not supported	single (dual) subcarrier load modulation ASK	single subcarrier load modulation ASK
	bit length (µs)	-	-	37.76 (37.46)	18.88
	bit encoding	-	-	Manchester coding	Manchester coding

Communication direction	Signal type	Transfer speed			
		6.62 (6.67) kbit/s	13.24 kbit/s ^[1]	26.48 (26.69) kbit/s	52.96 kbit/s
	subcarrier frequency [MHz]	-	-	$f_c / 32$ ($f_c / 28$)	$f_c / 32$

[1] Fast inventory (page) read command only (ICODE proprietary command).

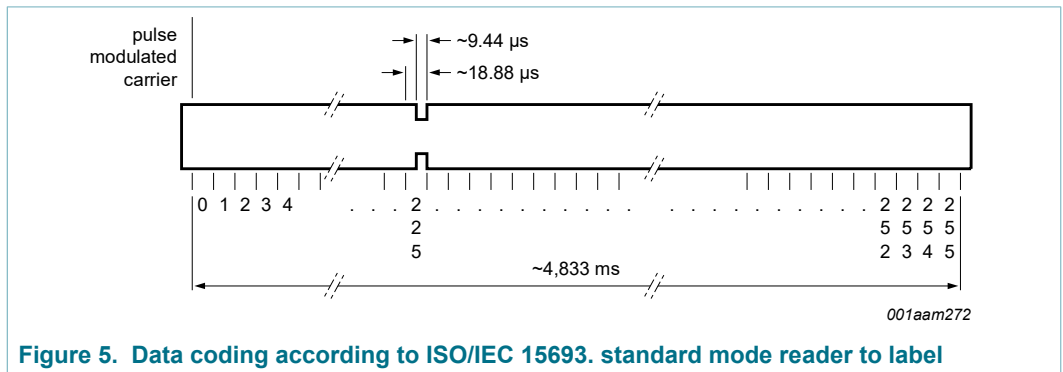

Figure 5. Data coding according to ISO/IEC 15693. standard mode reader to label

8.3.2 EPC-UID/UID-OTP functionality

The physical parameters are described in [Table 7](#).

Table 8. Communication overview for EPC/UID

Communication direction	Signal type	Transfer speed	
		26.48 kbit/s	52.96 kbit/s
Reader to card (send data from the SLRC610 to a card)	reader side modulation	10 % to 30 % ASK	
	bit encoding	RTZ	
	bit length	37.76 μs	
Card to reader (SLRC610 receives data from a card)	card side modulation		single subcarrier load modulation
	bit length		18.88 μs
	bit encoding		Manchester coding

Data coding and framing according to EPC global 13.56 MHz ISM (industrial, scientific and medical) Band Class 1 Radio Frequency Identification Tag Interface Specification (Candidate Recommendation, Version 1.0.0).

8.3.3 ISO/IEC 18000-3 mode 3/ EPC Class-1 HF functionality

The ISO/IEC 18000-3 mode 3/ EPC Class-1 HF is not described in this document. For a detailed explanation of the protocol, refer to the ISO/IEC 18000-3 mode 3/ EPC Class-1 HF standard.

8.3.3.1 Data encoding ICODE

The ICODE protocols have mainly three different methods of data encoding:

- "1" out of "4" coding scheme
- "1" out of "256" coding scheme
- "Return to Zero" (RZ) coding scheme

Data encoding for all three coding schemes is done by the ICODE generator.

The supported EPC Class-1 HF modes are:

- 2 pulse for 424 kbit subcarrier
- 4 pulse for 424 kbit subcarrier
- 2 pulse for 848 kbit subcarrier
- 4 pulse for 848 kbit subcarrier

8.4 Host interfaces

8.4.1 Host interface configuration

The SLRC610 supports direct interfacing of various hosts as the SPI, I²C, I²CL and serial UART interface type. The SLRC610 resets its interface and checks the current host interface type automatically having performed a power-up or resuming from power down. The SLRC610 identifies the host interface by the means of the logic levels on the control pins after the Cold Reset Phase. This is done by a combination of fixed pin connections. The following table shows the possible configurations defined by IFSEL1,IFSEL0:

Table 9. Connection scheme for detecting the different interface types

Pin	Pin Symbol	UART	SPI	I ² C	I ² C-L
28	IF0	RX	MOSI	ADR1	ADR1
29	IF1	n.c.	SCK	SCL	SCL
30	IF2	TX	MISO	ADR2	SDA
31	IF3	PAD_VDD	NSS	SDA	ADR2
26	IFSEL0	VSS	VSS	PAD_VDD	PAD_VDD
27	IFSEL1	VSS	PAD_VDD	VSS	PAD_VDD

8.4.2 SPI interface

8.4.2.1 General

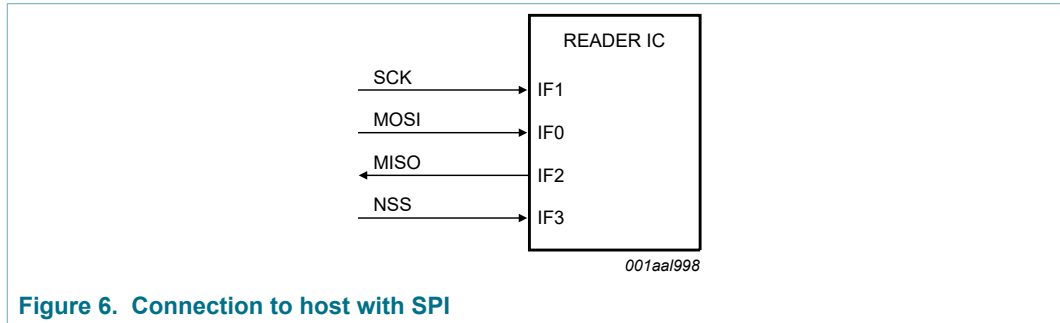

Figure 6. Connection to host with SPI

The SLRC610 acts as a slave during the SPI communication. The SPI clock SCK has to be generated by the master. Data communication from the master to the slave uses the Line MOSI. Line MISO is used to send data back from the SLRC610 to the master.

A serial peripheral interface (SPI compatible) is supported to enable high speed communication to a host. The implemented SPI compatible interface is according to a standard SPI interface. The SPI compatible interface can handle data speed of up to 10 Mbit/s. In the communication with a host SLRC610 acts as a slave receiving data from the external host for register settings and to send and receive data relevant for the communication on the RF interface.

NSS (Not Slave Select) enables or disables the SPI interface. When NSS is logical high, the interface is disabled and reset. Between every SPI command the NSS must go to logical high to be able to start the next command read or write.

On both data lines (MOSI, MISO) each data byte is sent by MSB first. Data on MOSI line shall be stable on rising edge of the clock line (SCK) and is allowed to change on falling edge. The same is valid for the MISO line. Data is provided by the SLRC610 on the falling edge and is stable on the rising edge. The polarity of the clock is low at SPI idle.

8.4.2.2 Read data

To read out data from the SLRC610 by using the SPI compatible interface the following byte order has to be used.

The first byte that is sent defines the mode (LSB bit) and the address.

Table 10. Byte Order for MOSI and MISO

	byte 0	byte 1	byte 2	byte 3 to n-1	byte n	byte n+1
MOSI	address 0	address 1	address 2	address n	00h
MISO	X	data 0	data 1	data n - 1	data n

Remark: The Most Significant Bit (MSB) has to be sent first.

8.4.2.3 Write data

To write data to the SLRC610 using the SPI interface the following byte order has to be used. It is possible to write more than one byte by sending a single address byte (see.8.5.2.4).

The first send byte defines both, the mode itself and the address byte.

Table 11. Byte Order for MOSI and MISO

	byte 0	byte 1	byte 2	3 to n-1	byte n	byte n + 1
MOSI	address 0	data 0	data 1	data n - 1	data n
MISO	X	X	X	X	X

Remark: The Most Significant Bit (MSB) has to be sent first.

8.4.2.4 Address byte

The address byte has to fulfil the following format:

The LSB bit of the first byte defines the used mode. To read data from the SLRC610 the LSB bit is set to logic 1. To write data to the SLRC610 the LSB bit has to be cleared. The bits 6 to 0 define the address byte.

NOTE: When writing the sequence [address byte][data0][data1][data2]..., [data0] is written to address [address byte], [data1] is written to address [address byte + 1] and [data2] is written to [address byte + 2].

Exception: This auto increment of the address byte is not performed if data is written to the FIFO address

Table 12. Address byte 0 register; address MOSI

7	6	5	4	3	2	1	0
address 6	address 5	address 4	address 3	address 2	address 1	address 0	1 (read) 0 (write)
MSB							LSB

8.4.2.5 Timing Specification SPI

The timing condition for SPI interface is as follows:

Table 13. Timing conditions SPI

Symbol	Parameter	Min	Typ	Max	Unit
t _{SCKL}	SCK LOW time	50	-	-	ns
t _{SCKH}	SCK HIGH time	50	-	-	ns
t _{h(SCKH-D)}	SCK HIGH to data input hold time	25	-	-	ns
t _{su(D-SCKH)}	data input to SCK HIGH set-up time	25	-	-	ns
t _{h(SCKL-Q)}	SCK LOW to data output hold time	-	-	25	ns
t _(SCKL-NSSH)	SCK LOW to NSS HIGH time	0	-	-	ns
t _{NSSH}	NSS HIGH time	50	-	-	ns



Figure 7. Connection to host with SPI

Remark: To send more bytes in one data stream the NSS signal must be LOW during the send process. To send more than one data stream the NSS signal must be HIGH between each data stream.

8.4.3 RS232 interface

8.4.3.1 Selection of the transfer speeds

The internal UART interface is compatible to a RS232 serial interface. The levels supplied to the pins are between VSS and PVDD. To achieve full compatibility of the voltage levels to the RS232 specification, a RS232 level shifter is required.

[Table 14 "Selectable transfer speeds"](#) describes examples for different transfer speeds and relevant register settings. The resulting transfer speed error is less than 1.5 % for all described transfer speeds. The default transfer speed is 115.2 kbit/s.

To change the transfer speed, the host controller has to write a value for the new transfer speed to the register SerialSpeedReg. The bits BR_T0 and BR_T1 define factors to set the transfer speed in the SerialSpeedReg.

[Table 13 "Settings of BR_T0 and BR_T1"](#) describes the settings of BR_T0 and BR_T1.

Table 14. Settings of BR_T0 and BR_T1

BR_T0	0	1	2	3	4	5	6	7
factor BR_T0	1	1	2	4	8	16	32	64
range BR_T1	1 to 32	33 to 64	33 to 64	33 to 64	33 to 64	33 to 64	33 to 64	33 to 64

Table 15. Selectable transfer speeds

Transfer speed (kbit/s)	Serial SpeedReg	Transfer speed accuracy (%)
	(Hex.)	
7.2	FA	-0.25
9.6	EB	0.32

Transfer speed (kbit/s)	Serial SpeedReg (Hex.)	Transfer speed accuracy (%)
14.4	DA	-0.25
19.2	CB	0.32
38.4	AB	0.32
57.6	9A	-0.25
115.2	7A	-0.25
128	74	-0.06
230.4	5A	-0.25
460.8	3A	-0.25
921.6	1C	1.45
1228.8	15	0.32

The selectable transfer speeds as shown are calculated according to the following formulas:

if BR_T0 = 0: transfer speed = 27.12 MHz / (BR_T1 + 1)
 if BR_T0 > 0: transfer speed = 27.12 MHz / (BR_T1 + 33)/2^(BR_T0 - 1)

Remark: Transfer speeds above 1228.8 kBits/s are not supported.

8.4.3.2 Framing

Table 16. UART framing

Bit	Length	Value
Start bit (Sa)	1 bit	0
Data bits	8 bit	Data
Stop bit (So)	1 bit	1

Remark: For data and address bytes the LSB bit has to be sent first. No parity bit is used during transmission.

Read data: To read out data using the UART interface the flow described below has to be used. The first send byte defines both the mode itself and the address. The Trigger on pin IF3 has to be set, otherwise no read of data is possible.

Table 17. Byte Order to Read Data

Mode	byte 0	byte 1
RX	address	-
TX	-	data 0

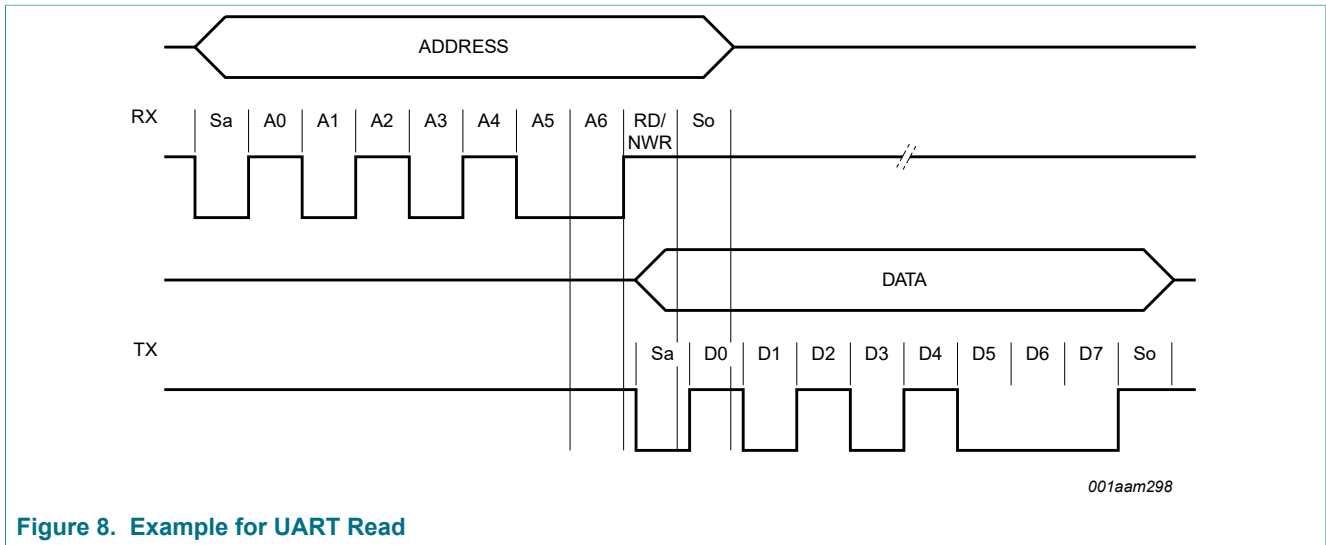

Figure 8. Example for UART Read

Write data:

To write data to the SLRC610 using the UART interface the following sequence has to be used.

The first send byte defines both, the mode itself and the address.

Table 18. Byte Order to Write Data

Mode	byte 0	byte 1
RX	address 0	data 0
TX		address 0

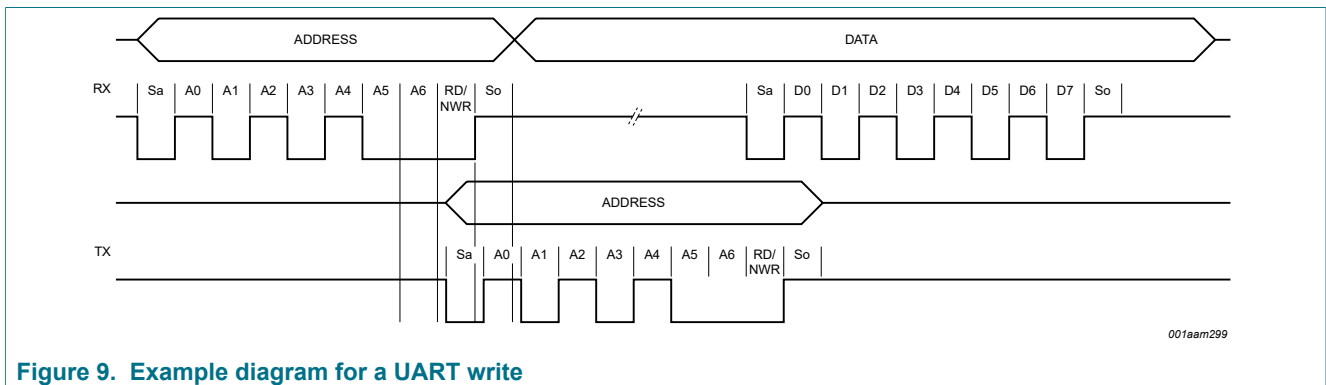

Figure 9. Example diagram for a UART write

Remark: Data can be sent before address is received.

8.4.4 I²C-bus interface

8.4.4.1 General

An Inter IC (I²C) bus interface is supported to enable a low cost, low pin count serial bus interface to the host. The implemented I²C interface is mainly implemented according the NXP Semiconductors I²C interface specification, rev. 3.0, June 2007. The SLRC610 can

act as a slave receiver or slave transmitter in standard mode, fast mode and fast mode plus.

The following features defined by the NXP Semiconductors I²C interface specification, rev. 3.0, June 2007 are not supported:

- The SLRC610 I2C interface does not stretch the clock
- The SLRC610 I2C interface does not support the general call. This means that the SLRC610 does not support a software reset
- The SLRC610 does not support the I2C device ID
- The implemented interface can only act in slave mode. Therefore no clock generation and access arbitration is implemented in the SLRC610.
- High speed mode is not supported by the SLRC610

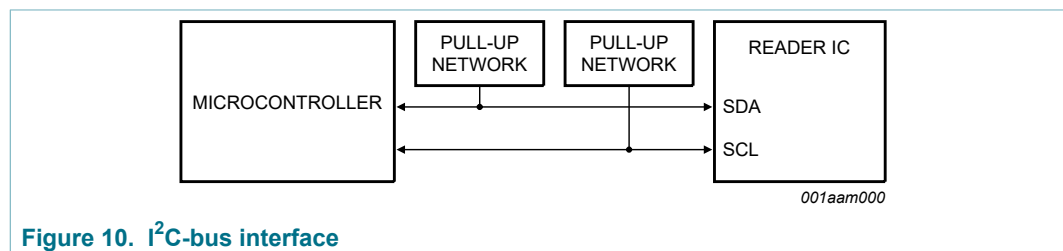

Figure 10. I²C-bus interface

The voltage level on the I2C pins is not allowed to be higher than PVDD.

SDA is a bidirectional line, connected to a positive supply voltage via a pull-up resistor. Both lines SDA and SCL are set to HIGH level if no data is transmitted. Data on the I²C-bus can be transferred at data rates of up to 400 kbit/s in fast mode, up to 1 Mbit/s in the fast mode+.

If the I²C interface is selected, a spike suppression according to the I²C interface specification on SCL and SDA is automatically activated.

For timing requirements refer to [Table 200 "I2C-bus timing in fast mode and fast mode plus"](#)

8.4.4.2 I²C Data validity

Data on the SDA line shall be stable during the HIGH period of the clock. The HIGH state or LOW state of the data line shall only change when the clock signal on SCL is LOW.

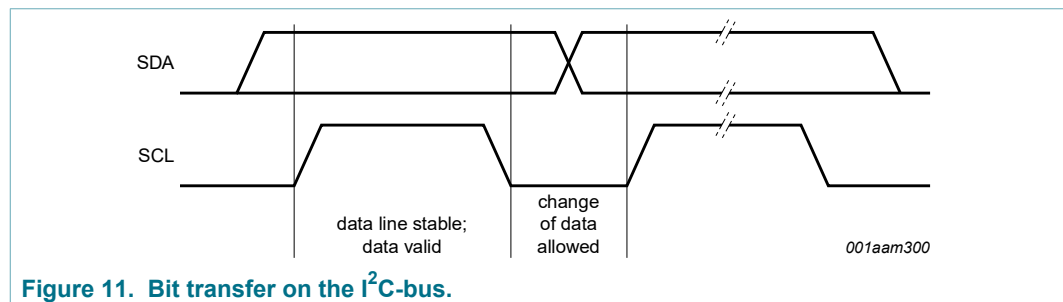

Figure 11. Bit transfer on the I²C-bus.

8.4.4.3 I²C START and STOP conditions

To handle the data transfer on the I²C-bus, unique START (S) and STOP (P) conditions are defined.

A START condition is defined with a HIGH-to-LOW transition on the SDA line while SCL is HIGH.

A STOP condition is defined with a LOW-to-HIGH transition on the SDA line while SCL is HIGH.

The master always generates the START and STOP conditions. The bus is considered to be busy after the START condition. The bus is considered to be free again a certain time after the STOP condition.

The bus stays busy if a repeated START (Sr) is generated instead of a STOP condition. In this respect, the START (S) and repeated START (Sr) conditions are functionally identical. Therefore, the S symbol will be used as a generic term to represent both the START and repeated START (Sr) conditions.



Figure 12. START and STOP conditions

8.4.4.4 I²C byte format

Each byte has to be followed by an acknowledge bit. Data is transferred with the MSB first, see Figure 12 "START and STOP conditions". The number of transmitted bytes during one data transfer is unrestricted but shall fulfil the read/write cycle format.

8.4.4.5 I²C Acknowledge

An acknowledge at the end of one data byte is mandatory. The acknowledge-related clock pulse is generated by the master. The transmitter of data, either master or slave, releases the SDA line (HIGH) during the acknowledge clock pulse. The receiver shall pull down the SDA line during the acknowledge clock pulse so that it remains stable LOW during the HIGH period of this clock pulse.

The master can then generate either a STOP (P) condition to stop the transfer, or a repeated START (Sr) condition to start a new transfer.

A master-receiver shall indicate the end of data to the slave- transmitter by not generating an acknowledge on the last byte that was clocked out by the slave. The slave-transmitter shall release the data line to allow the master to generate a STOP (P) or repeated START (Sr) condition.



Figure 13. Acknowledge on the I²C-bus



Figure 14. Data transfer on the I²C-bus

8.4.4.6 I²C 7-bit addressing

During the I²C-bus addressing procedure, the first byte after the START condition is used to determine which slave will be selected by the master.

Alternatively the I²C address can be configured in the EEPROM. Several address numbers are reserved for this purpose. During device configuration, the designer has to ensure, that no collision with these reserved addresses in the system is possible. Check the corresponding I²C specification for a complete list of reserved addresses.

For all SLRC610 devices the upper 5 bits of the device bus address are reserved by NXP and set to 01010(bin). The remaining 2 bits (ADR₂, ADR₁) of the slave address can be freely configured by the customer in order to prevent collisions with other I²C devices by using the interface pins (refer to Table 8) or the value of the I²C address EEPROM register (refer to Table 30).

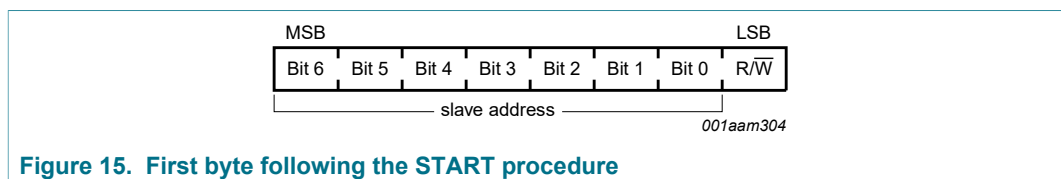

Figure 15. First byte following the START procedure

8.4.4.7 I²C-register write access

To write data from the host controller via I²C to a specific register of the SLRC610 the following frame format shall be used.

The read/write bit shall be set to logic 0.

The first byte of a frame indicates the device address according to the I²C rules. The second byte indicates the register address followed by up to n-data bytes. In case the address indicates the FIFO, in one frame all n-data bytes are written to the FIFO register address. This enables for example a fast FIFO access.

8.4.4.8 I²C-register read access

To read out data from a specific register address of the SLRC610 the host controller shall use the procedure:

First a write access to the specific register address has to be performed as indicated in the following frame:

The first byte of a frame indicates the device address according to the I²C rules. The second byte indicates the register address. No data bytes are added.

The read/write bit shall be logic 0.

Having performed this write access, the read access starts. The host sends the device address of the SLRC610. As an answer to this device address the SLRC610 responds with the content of the addressed register. In one frame n-data bytes could be read using the same register address. The address pointing to the register is incremented automatically (exception: FIFO register address is not incremented automatically). This enables a fast transfer of register content. The address pointer is incremented automatically and data is read from the locations [address], [address+1], [address+2]... [address+(n-1)]

In order to support a fast FIFO data transfer, the address pointer is not incremented automatically in case the address is pointing to the FIFO.

The read/write bit shall be set to logic 1.

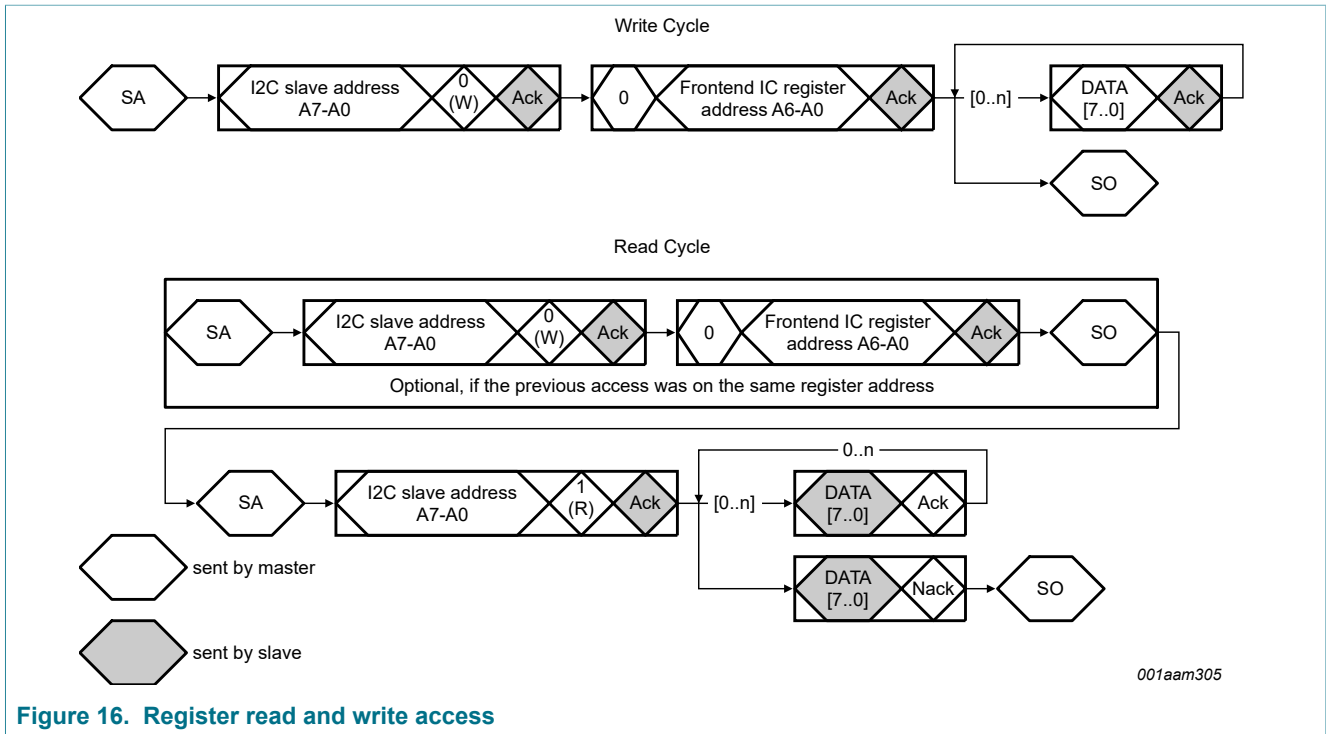

Figure 16. Register read and write access

8.4.4.9 I²CL-bus interface

The SLRC610 provides an additional interface option for connection of a SAM. This logical interface fulfills the I²C specification, but the rise/fall timings will not be compliant to the I²C standard. The I²CL interface uses standard I/O pads, and the communication speed is limited to 5 MBaud. The protocol itself is equivalent to the fast mode protocol of I²C. The SCL levels are generated by the host in push/pull mode. The RC610 does not stretch the clock. During the high period of SCL the status of the line is maintained by a bus keeper.

The address is 01010xxb, where the last two bits of the address can be defined by the application. The definition of this bits can be done by two options. With a pin, where the higher bit is fixed to 0 or the configuration can be defined via EEPROM. Refer to the EEPROM configuration in [Section 7.7](#).

Table 19. Timing parameter I²CL

Parameter	Min	Max	Unit
f _{SCL}	0	5	MHz
t _{HD;STA}	80	-	ns
t _{LOW}	100	-	ns
t _{HIGH}	100	-	ns
t _{SU;SDA}	80	-	ns
t _{HD;DAT}	0	50	ns
t _{SU;DAT}	0	20	ns
t _{SU;STO}	80	-	ns
t _{BUF}	200	-	ns

The pull-up resistor is not required for the I²CL interface. Instead, a on chip buskeeper is implemented in the SLRC610 for SDA of the I²CL interface. This protocol is intended to be used for a point to point connection of devices over a short distance and does not support a bus capability. The driver of the pin must force the line to the desired logic voltage. To avoid that two drivers are pushing the line at the same time following regulations must be fulfilled:

SCL: As there is no clock stretching, the SCL is always under control of the Master.

SDA: The SDA line is shared between master and slave. Therefore the master and the slave must have the control over the own driver enable line of the SDA pin. The following rules must be followed:

- In the idle phase the SDA line is driven high by the master
- In the time between start and stop condition the SDA line is driven by master or slave when SCL is low. If SCL is high the SDA line is not driven by any device
- To keep the value on the SDA line a on chip buskeeper structure is implemented for the line

8.4.5 SAM interface

8.4.5.1 SAM functionality

The SLRC610 implements a dedicated I2C or SPI interface to integrate a SAM (Secure Access Module) in a very convenient way into applications (e.g. a proximity reader).

The SAM can be connected to the microcontroller to operate like a cryptographic co-processor. For any cryptographic task, the microcontroller requests a operation from the SAM, receives the answer and sends it over a host interface (e.g. I2C, SPI) interface to the connected reader IC.

8.4.5.2 SAM connection

The SLRC610 provides an interface to connect a SAM dedicated to the SLRC610. Both interface options of the SLRC610, I²C, I²CL or SPI can be used for this purpose. The interface option of the SAM itself is configured by a host command sent from the host to the SAM.

The I²CL interface is intended to be used as connection between two IC's over a short distance. The protocol fulfills the I²C specification, but does support a single device connected to the bus only.

The SPI block for SAM connection is identical with the SPI host interface block.

The pins used for the SAM SPI are described in [Table 19](#).

Table 20. SPI SAM connection

SPI functionality	PIN
MISO	SDA2
SCL	SCL2
MOSI	IFSEL1
NSS	IFSEL0

8.4.6 Boundary scan interface

The SLRC610 provides a boundary scan interface according to the IEEE 1149.1. This interface allows to test interconnections without using physical test probes. This is done by test cells, assigned to each pin, which override the functionality of this pin.

To be able to program the test cells, the following commands are supported:

Table 21. Boundary scan command

Value (decimal)	Command	Parameter in	Parameter out
0	bypass	-	-
1	preload	data (24)	-
1	sample	-	data (24)
2	ID code (default)	-	data (32)
3	USER code	-	data (32)
4	Clamp	-	-
5	HIGH Z	-	-
7	extest	data (24)	data (24)
8	interface on/off	interface (1)	-
9	register access read	address (7)	data (8)
10	register access write	address (7) - data (8)	-

The Standard IEEE 1149.1 describes the four basic blocks necessary to use this interface: Test Access Port (TAP), TAP controller, TAP instruction register, TAP data register;

8.4.6.1 Interface signals

The boundary scan interface implements a four line interface between the chip and the environment. There are three Inputs: Test Clock (TCK); Test Mode Select (TMS); Test Data Input (TDI) and one output Test Data Output (TDO). TCK and TMS are broadcast signals, TDI to TDO generate a serial line called Scan path.

Advantage of this technique is that independent of the numbers of boundary scan devices the complete path can be handled with four signal lines.

The signals TCK, TMS are directly connected with the boundary scan controller. Because these signals are responsible for the mode of the chip, all boundary scan devices in one scan path will be in the same boundary scan mode.

8.4.6.2 Test Clock (TCK)

The TCK pin is the input clock for the module. If this clock is provided, the test logic is able to operate independent of any other system clocks. In addition, it ensures that multiple boundary scan controllers that are daisy-chained together can synchronously communicate serial test data between components. During normal operation, TCK is driven by a free-running clock. When necessary, TCK can be stopped at 0 or 1 for extended periods of time. While TCK is stopped at 0 or 1, the state of the boundary scan controller does not change and data in the Instruction and Data Registers is not lost.

The internal pull-up resistor on the TCK pin is enabled. This assures that no clocking occurs if the pin is not driven from an external source.

8.4.6.3 Test Mode Select (TMS)

The TMS pin selects the next state of the boundary scan controller. TMS is sampled on the rising edge of TCK. Depending on the current boundary scan state and the sampled value of TMS, the next state is entered. Because the TMS pin is sampled on the rising edge of TCK, the IEEE Standard 1149.1 expects the value on TMS to change on the falling edge of TCK.

Holding TMS high for five consecutive TCK cycles drives the boundary scan controller state machine to the Test-Logic-Reset state. When the boundary scan controller enters the Test-Logic-Reset state, the Instruction Register (IR) resets to the default instruction, ICODE. Therefore, this sequence can be used as a reset mechanism.

The internal pull-up resistor on the TMS pin is enabled.

8.4.6.4 Test Data Input (TDI)

The TDI pin provides a stream of serial information to the IR chain and the DR chains. TDI is sampled on the rising edge of TCK and, depending on the current TAP state and the current instruction, presents this data to the proper shift register chain. Because the TDI pin is sampled on the rising edge of TCK, the IEEE Standard 1149.1 expects the value on TDI to change on the falling edge of TCK.

The internal pull-up resistor on the TDI pin is enabled.

8.4.6.5 Test Data Output (TDO)

The TDO pin provides an output stream of serial information from the IR chain or the DR chains. The value of TDO depends on the current TAP state, the current instruction, and the data in the chain being accessed. In order to save power when the port is not being used, the TDO pin is placed in an inactive drive state when not actively shifting out data. Because TDO can be connected to the TDI of another controller in a daisy-chain configuration, the IEEE Standard 1149.1 expects the value on TDO to change on the falling edge of TCK.

8.4.6.6 Data register

According to the IEEE 1149.1 standard there are two types of data register defined: bypass and boundary scan

The bypass register enable the possibility to bypass a device when part of the scan path. Serial data is allowed to be transferred through a device from the TDI pin to the TDO pin without affecting the operation of the device.

The boundary scan register is the scan-chain of the boundary cells. The size of this register is dependent on the command.

8.4.6.7 Boundary scan cell

The boundary scan cell opens the possibility to control a hardware pin independent of its normal use case. Basically the cell can only do one of the following: control, output and input.

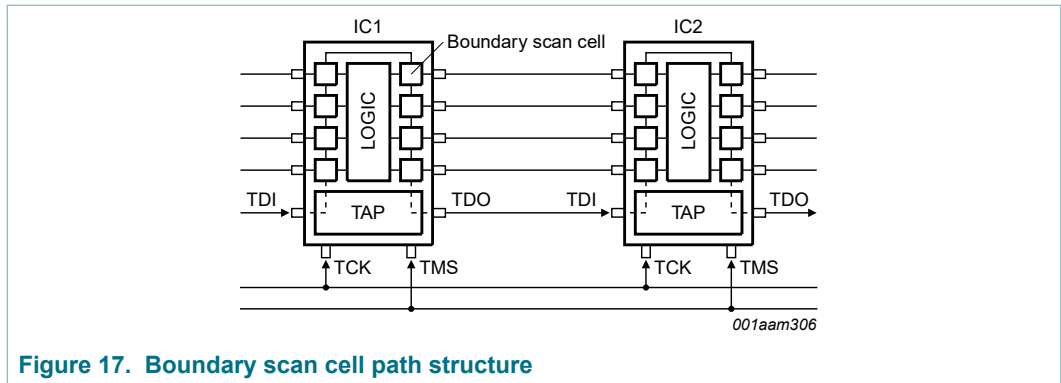

Figure 17. Boundary scan cell path structure

8.4.6.8 Boundary scan path

This chapter shows the boundary scan path of the SLRC610.

Table 22. Boundary scan path of the SLRC610

Number (decimal)	Cell	Port	Function
23	BC_1	-	Control
22	BC_8	CLKOUT	Bidir
21	BC_1	-	Control
20	BC_8	SCL2	Bidir
19	BC_1	-	Control
18	BC_8	SDA2	Bidir
17	BC_1	-	Control
16	BC_8	IFSEL0	Bidir
15	BC_1	-	Control
14	BC_8	IFSEL1	Bidir
13	BC_1	-	Control
12	BC_8	IF0	Bidir
11	BC_1	-	Control
10	BC_8	IF1	Bidir
9	BC_1	-	Control
8	BC_8	IF2	Bidir
7	BC_1	IF2	Output2
6	BC_4	IF3	Bidir
5	BC_1	-	Control
4	BC_8	IRQ	Bidir
3	BC_1	-	Control
2	BC_8	SIGIN	Bidir
1	BC_1	-	Control
0	BC_8	SIGOUT	Bidir

Refer to the SLRC610 BSDL file.

8.4.6.9 Boundary Scan Description Language (BSDL)

All of the boundary scan devices have a unique boundary structure which is necessary to know for operating the device. Important components of this language are:

- available test bus signal
- compliance pins
- command register
- data register
- boundary scan structure (number and types of the cells, their function and the connection to the pins.)

The SLRC610 is using the cell BC_8 for the IO-Lines. The I²C Pin is using a BC_4 cell. For all pad enable lines the cell BC1 is used.

The manufacturer's identification is 02Bh.

- attribute IDCODEISTER of SLRC610: entity is "0001" and -- version
- "0011110010000010b" and -- part number (3C82h)
- "00000010101b" and -- manufacturer (02Bh)
- "1b"; -- mandatory

The user code data is coded as followed:

- product ID (3 bytes)
- version

These four bytes are stored as the first four bytes in the EEPROM.

8.4.6.10 Non-IEEE1149.1 commands

Interface on/off: With this command the host/SAM interface can be deactivated and the Read and Write command of the boundary scan interface is activated. (Data = 1). With Update-DR the value is taken over.

Register Access Read: At Capture-DR the actual address is read and stored in the DR. Shifting the DR is shifting in a new address. With Update-DR this address is taken over into the actual address.

Register Access Write: At the Capture-DR the address and the data is taken over from the DR. The data is copied into the internal register at the given address.

8.5 Buffer

8.5.1 Overview

An 512 × 8-bit FIFO buffer is implemented in the SLRC610. It buffers the input and output data stream between the host and the internal state machine of the SLRC610. Thus, it is possible to handle data streams with lengths of up to 512 bytes without taking timing constraints into account. The FIFO can also be limited to a size of 255 byte. In this case all the parameters (FIFO length, Watermark...) require a single byte only for definition. In case of a 512 byte FIFO length the definition of this values requires 2 bytes.

8.5.2 Accessing the FIFO buffer

When the μ -Controller starts a command, the SLRC610 may, while the command is in progress, access the FIFO-buffer according to that command. Physically only one FIFO-buffer is implemented, which can be used in input and output direction. Therefore the μ -Controller has to take care, not to access the FIFO buffer in a way that corrupts the FIFO data.

8.5.3 Controlling the FIFO buffer

Besides writing to and reading from the FIFO buffer, the FIFO-buffer pointers might be reset by setting the bit FIFOFlush in FIFOControl to 1. Consequently, the FIFOLevel bits are set to logic 0, the actually stored bytes are not accessible any more and the FIFO buffer can be filled with another 512 bytes (or 255 bytes if the bit FIFOSize is set to 1) again.

8.5.4 Status Information about the FIFO buffer

The host may obtain the following data about the FIFO-buffers status:

- Number of bytes already stored in the FIFO-buffer. Writing increments, reading decrements the FIFO level: FIFOLength in register FIFOLength (and FIFOControl Register in 512 byte mode)
- Warning, that the FIFO-buffer is almost full: HiAlert in register FIFOControl according to the value of the water level in register WaterLevel (Register 02h bit [2], Register 03h bit[7:0])
- Warning, that the FIFO-buffer is almost empty: LoAlert in register FIFOControl according to the value of the water level in register WaterLevel (Register 02h bit [2], Register 03h bit[7:0])
- FIFOOvl bit indicates, that bytes were written to the FIFO buffer although it was already full: ErrIRQ in register IRQ0.

WaterLevel is one single value defining both HiAlert (counting from the FIFO top) and LoAlert (counting from the FIFO bottom). The CLRC663 can generate an interrupt signal if:

- LoAlertIRQEn in register IRQ0En is set to logic 1 it will activate pin IRQ when LoAlert in the register FIFOControl changes to 1.
- HiAlertIRQEN in register IRQ0En is set to logic 1 it will activate pin IRQ when HiAlert in the register FIFOControl changes to 1.

The bit HiAlert is set to logic 1 if maximum water level bytes (as set in register WaterLevel) or less can be stored in the FIFO-buffer. It is generated according to the following equation:

$$HiAlert = (FIFOSize + - FIFOLength) \leq WaterLevel$$

(2)

The bit LoAlert is set to logic 1 if water level bytes (as set in register WaterLevel) or less are actually stored in the FIFO-buffer. It is generated according to the following equation:

$$LoAlert = FIFOLength \leq WaterLevel$$

(3)

8.6 Analog interface and contactless UART

8.6.1 General

The integrated contactless UART supports the external host online with framing and error checking of the protocol requirements up to 848 kbit/s. An external circuit can be connected to the communication interface pins SIGIN and SIGOUT to modulate and demodulate the data.

The contactless UART handles the protocol requirements for the communication schemes in co-operation with the host. The protocol handling itself generates bit- and byte-oriented framing and handles error detection like Parity and CRC according to the different contactless communication schemes.

The size, the tuning of the antenna, and the supply voltage of the output drivers have an impact on the achievable field strength. The operating distance between reader and card depends additionally on the type of card used.

8.6.2 TX transmitter

The signal delivered on pin TX1 and pin TX2 is the 13.56 MHz carrier modulated by an envelope signal for energy and data transmission. It can be used to drive an antenna directly, using a few passive components for matching and filtering, see [Section 13 "Application information"](#). The signal on TX1 and TX2 can be configured by the register DrvMode, see [Section 8.8.1 "TxMode"](#).

The modulation index can be set by the TxAmp.

Following figure shows the general relations during modulation

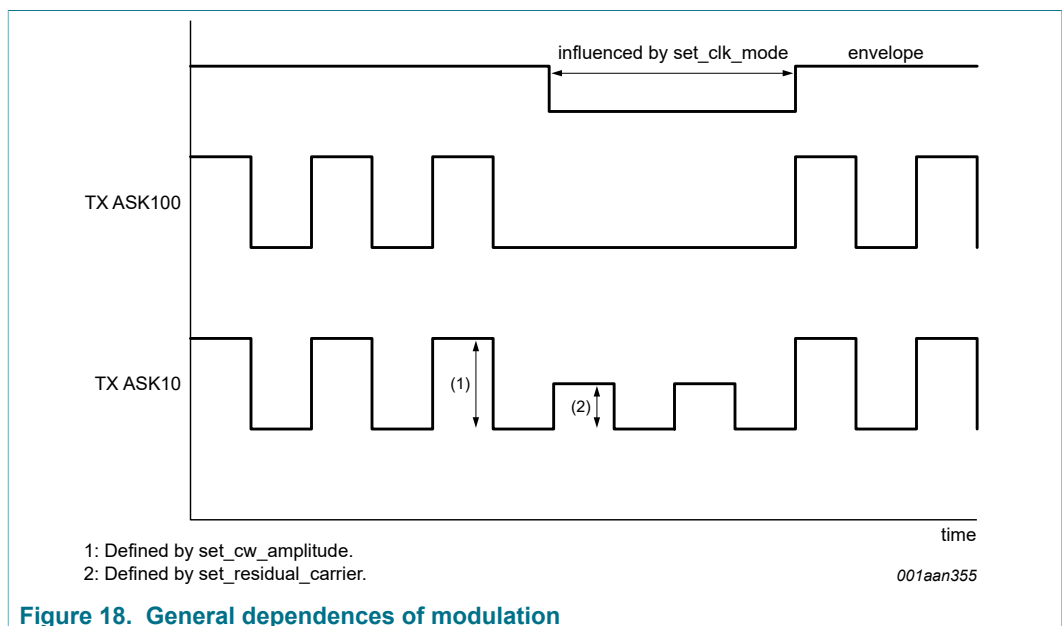

Figure 18. General dependences of modulation

Note: When changing the continuous carrier amplitude, the residual carrier amplitude also changes, while the modulation index remains the same.

The registers [Section 8.8](#) and [Section 8.10](#) control the data rate, the framing during transmission and the setting of the antenna driver to support the requirements at the different specified modes and transfer speeds.

Table 23. Settings for TX1 and TX2

TxClockMode (binary)	Tx1 and TX2 output	Remarks
000	High impedance	-
001	0	output pulled to 0 in any case
010	1	output pulled to 1 in any case
110	RF high side push	open drain, only high side (push) MOS supplied with clock, clock parity defined by invtx; low side MOS is off
101	RF low side pull	open drain, only low side (pull) MOS supplied with clock, clock parity defined by invtx; high side MOS is off
111	13.56 MHz clock derived from 27.12 MHz quartz divided by 2	push/pull Operation, clock polarity defined by invtx; setting for 10% modulation

Register TXamp and the bits for set_residual_carrier define the modulation index:

Table 24. Setting residual carrier and modulation index by TXamp.set_residual_carrier

set_residual_carrier (decimal)	residual carrier [%]	modulation index [%]
0	99	0.5
1	98	1.0
2	96	2.0
3	94	3.1
4	91	4.7
5	89	5.8
6	87	7.0
7	86	7.5
8	85	8.1
9	84	8.7
10	83	9.3
11	82	9.9
12	81	10.5
13	80	11.1
14	79	11.7
15	78	12.4
16	77	13.0
17	76	13.6
18	75	14.3

set_residual_carrier (decimal)	residual carrier [%]	modulation index [%]
19	74	14.9
20	72	16.3
21	70	17.6
22	68	19.0
23	65	21.2
24	60	25.0
25	55	29.0
26	50	33.3
27	45	37.9
28	40	42.9
29	35	48.1
30	30	53.8
31	25	60.0

Note: At VDD(TVDD) <5 V and residual carrier settings <50%, the accuracy of the modulation index may be low in dependency of the antenna tuning impedance

8.6.2.1 Overshoot protection

The SLRC610 provides an overshoot protection for 100% ASK to avoid overshoots during a PCD communication. Therefore two timers overshoot_t1 and overshoot_t2 can be used.

During the timer overshoot_t1 runs an amplitude defined by set_cw_amplitude bits is provided to the output driver. Followed by an amplitude denoted by set_residual_carrier bits with the duration of overshoot_t2.

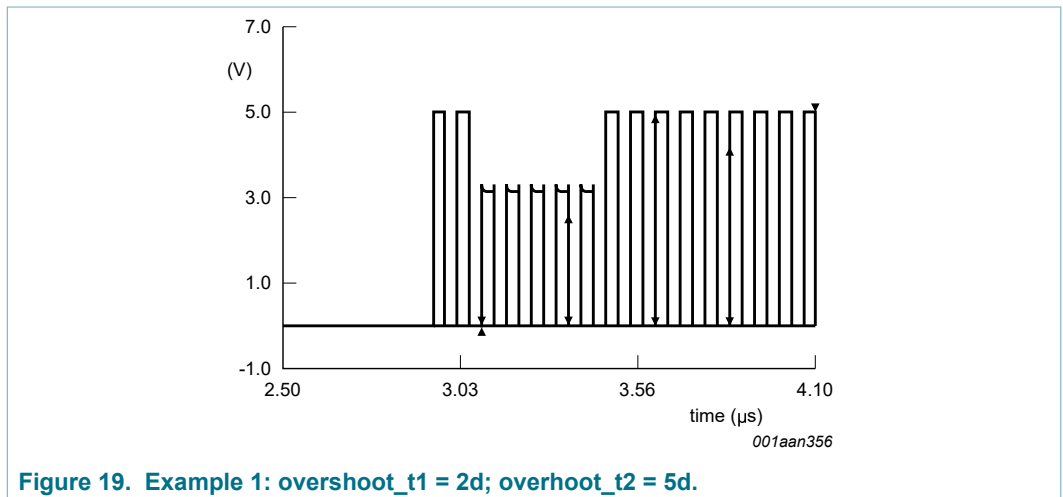

Figure 19. Example 1: overshoot_t1 = 2d; overshoot_t2 = 5d.



Figure 20. Example 2: overshoot_t1 = 0d; overshoot_t2 = 5d

8.6.2.2 Bit generator

The default coding of a data stream is done by using the Bit-Generator. It is activated when the value of TxFrameCon.DCodeType is set to 0000 (bin). The Bit-Generator encodes the data stream byte-wise and can apply the following encoding steps to each data byte.

1. Add a start-bit of specified type at beginning of every byte
2. Add a stop-bit and EGT bits of a specified type. The maximum number of EGT bit is 6, only full bits are supported
3. Add a parity-bit of a specified type
4. TxLastBits (skips a given number of bits at the end of the last byte in a frame)
5. Encrypt data-bit (MIFARE Classic encryption)

It is not possible to skip more than 8 bit of a single byte!

By default, data bytes are always treated LSB first.

8.6.3 Receiver circuitry

8.6.3.1 General

The SLRC610 features a versatile quadrature receiver architecture with fully differential signal input at RXP and RXN. It can be configured to achieve optimum performance for reception of various 13.56 MHz based protocols.

For all processing units various adjustments can be made to obtain optimum performance.

8.6.3.2 Block diagram

Figure 21 shows the block diagram of the receiver circuitry. The receiving process includes several steps. First the quadrature demodulation of the carrier signal of 13.56 MHz is done. Several tuning steps in this circuit are possible.

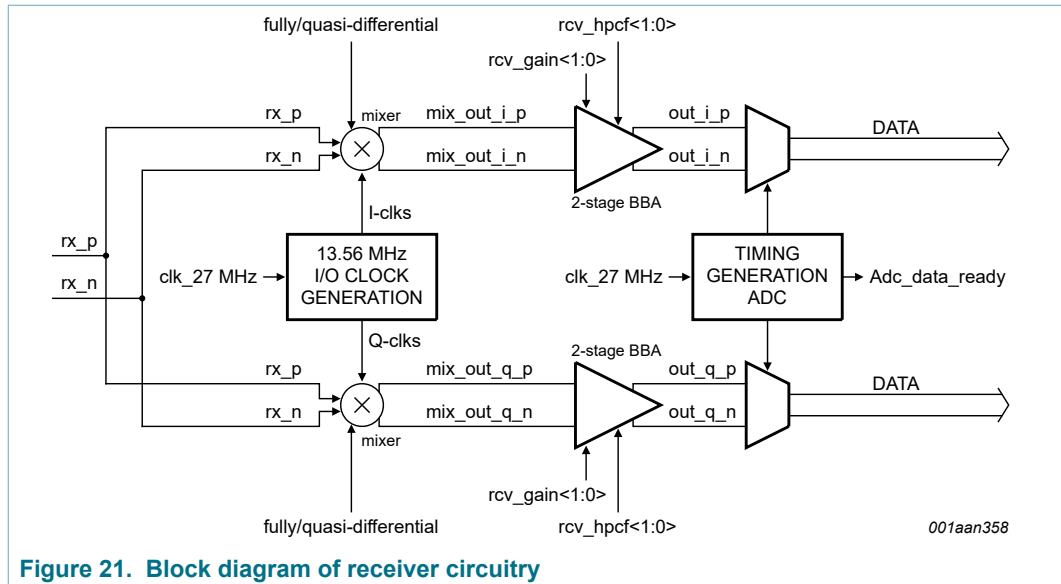

Figure 21. Block diagram of receiver circuitry

The receiver can also be operated in a single ended mode. In this case the Rcv_RX_single bit has to be set. In the single ended mode, the two receiver pins RXP and RXN need to be connected together and will provide a single ended signal to the receiver circuitry.

When using the receiver in a single ended mode the receiver sensitivity is decreased and the achievable reading distance might be reduced, compared to the fully differential mode.

Table 25. Configuration for single or differential receiver

Mode	rcv_rx_single	pins RXP and RXN
Fully differential	0	provide differential signal from differential antenna by separate rx-coupling branches
Quasi differential	1	connect RXP and RXN together and provide single ended signal from antenna by a single rx-coupling branch

The quadrature-demodulator uses two different clocks, Q-clock and I-clock, with a phase shift of 90° between them. Both resulting baseband signals are amplified, filtered, digitized and forwarded to a correlation circuitry.

The typical application is intended to implement the Fully differential mode and will deliver maximum reader/writer distance. The Quasi differential mode can be used together with dedicated antenna topologies that allow a reduction of matching components at the cost of overall reading performance.

During low power card detection the DC levels at the I- and Q-channel mixer outputs are evaluated. This requires that mixers are directly connected to the ADC. This can be configured by setting the bit Rx_ADCmode in register Rcv (38h).

8.6.4 Active antenna concept

Two main blocks are implemented in the SLRC610. A digital circuitry, comprising state machines, coder and decoder logic and an analog circuitry with the modulator and antenna drivers, receiver and amplification circuitry. For example, the interface between these two blocks can be configured in the way, that the interfacing signals may be routed to the pins SIGIN and SIGOUT. The most important use of this topology is the active antenna concept where the digital and the analog blocks are separated. This opens the possibility to connect e.g. an additional digital block of another SLRC610 device with a single analog antenna front-end.

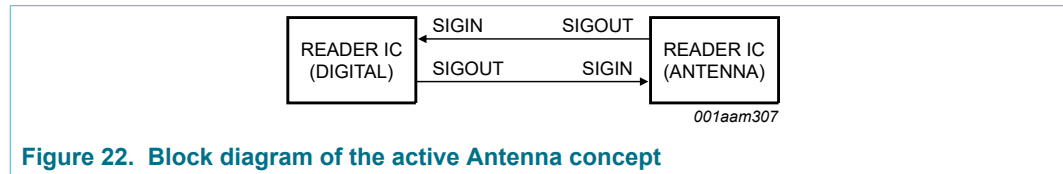

Figure 22. Block diagram of the active Antenna concept

The [Table 25](#) and [Table 26](#) describe the necessary register configuration for the use case active antenna concept.

Table 26. Register configuration of SLRC610 active antenna concept (DIGITAL)

Register	Value (binary)	Description
SigOut.SigOutSel	0100	TxEnvelope
Rcv.SigInSel	11	Receive over SigIn (Generic Code)
DrvCon.TxSel	00	Low (idle)

Table 27. Register configuration of SLRC610 active antenna concept (Antenna)

Register	Value (binary)	Description
SigOut.SigOutSel	0110	Generic Code (Manchester)
Rcv.SigInSel	01	Internal
DrvCon.TxSel	10	External (SigIn)
RxCtrl.RxMultiple	1	RxMultiple on

The interface between these two blocks can be configured in the way, that the interfacing signals may be routed to the pins SIGIN and SIGOUT (see [Figure 23 "Overview SIGIN/ SIGOUT Signal Routing"](#)).

This topology supports, that some parts of the analog part of the SLRC610 may be connected to the digital part of another device.

The switch SigOutSel in registerSigOut can be used to measure signals. This is especially important during the design In phase or for test purposes to check the transmitted and received data.

However, the most important use of SIGIN/SIGOUT pins is the active antenna concept. An external active antenna circuit can be connected to the digital circuit of the SLRC610. SigOutSel has to be configured in that way that the signal of the internal Miller Coder is sent to SIGOUT pin (SigOutSel = 4). SigInSel has to be configured to receive Manchester signal with sub-carrier from SIGIN pin (SigInSel = 1).

It is possible, to connect a passive antenna to pins TX1, TX2 and RX (via the appropriate filter and matching circuit) and at the same time an active antenna to the pins SIGOUT and SIGIN. In this configuration, two RF-parts may be driven (one after another) by a single host processor.



Figure 23. Overview SIGIN/SIGOUT Signal Routing

8.6.5 Symbol generator

The symbol generator is used to create various protocol symbols like the CS symbol as used by the ICODE EPC protocol.

Symbols are defined by means of the symbol definition registers and the mode registers. Four different symbols can be used. Two of them, Symbol0 and Symbol1 have a maximum pattern length of 16 bit and feature a burst length of up to 256 bits of either logic "0" or logic "1". The Symbol2 and Symbol3 are limited to 8 bit pattern length and do not support a burst.

The definition of symbol patterns is done by writing the bit sequence of the pattern to the appropriate register. The last bit of the pattern to be sent is located at the LSB of the register. By setting the symbol length in the symbol-length register (TxSym10Len and TxSym32Len) the definition of the symbol pattern is completed. All other bits at bit-position higher than the symbol length in the definition register are ignored. (Example: length of Symbol2 = 5, bit7 and bit6 are ignored, bit5 to bit0 define the symbol pattern, bit5 is sent first)

Which symbol-pattern is sent can be configured in the TxFrameCon register. Symbol0, Symbol1 and Symbol2 can be sent before data packets, Symbol1, Symbol2 and Symbol3 can be sent after data packets. Each symbol is defined by a set of registers. Symbols are configured by a pair of registers. Symbol0 and Symbol1 share the same configuration and Symbol2 and Symbol3 share the same configuration. The configuration includes setting of bit-clock- and subcarrier-frequency, as well as selection of the pulse type/length and the envelope type.

8.7 Memory

8.7.1 Memory overview

The SLRC610 implements three different memories: EEPROM, FIFO and Registers.

At startup, the initialization of the registers which define the behavior of the IC is performed by an automatic copy of an EEPROM area (read/write EEPROM section1 and section2, register reset) into the registers. The behavior of the SLRC610 can be changed by executing the command LoadProtocol, which copies a selected default protocol from the EEPROM (read only EEPROM section4, register Set Protocol area) into the registers.

The read/write EEPROM section2 can be used to store any user data or predefined register settings. These predefined settings can be copied with the command "LoadRegister" into the internal registers.

The FIFO is used as Input/Out buffer and is able to improve the performance of a system with limited interface speed.

8.7.2 EEPROM memory organization

The SLRC610 has implemented a EEPROM non-volatile memory with a size of 8 kB. The EEPROM is organized in pages of 64 bytes. One page of 64 bytes can be programmed at a time. Defined purposes had been assigned to specific memory areas of the EEPROM, which are called Sections. Five sections 0..4 with different purpose do exist.

Table 28. EEPROM memory organization

Section	Page	Byte addresses	Access rights	Memory content
0	0	00 to 31	r	product information and configuration
		32 to 63	r/w	product configuration
1	1 to 2	64 to 191	r/w	register reset
2	3 to 111	192 to 7167	r/w	free
3	112 to 128	7168 to 8191	r	Register Set Protocol (RSP, TX and RX)

The following figure show the structure of the EEPROM:

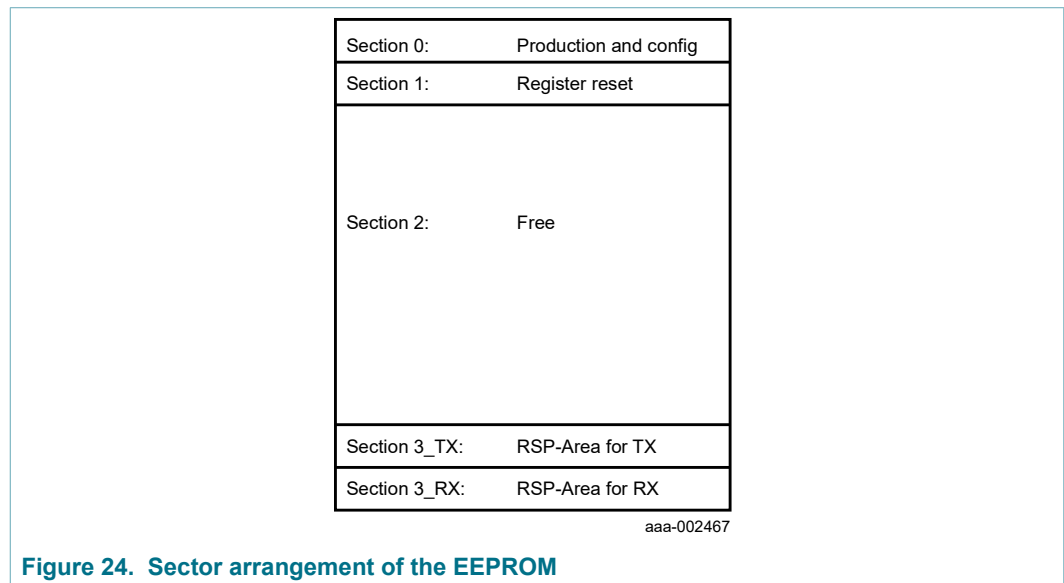

Figure 24. Sector arrangement of the EEPROM

8.7.2.1 Product information and configuration - Page 0

The first EEPROM page includes production data as well as configuration information.

Table 29. Production area (Page 0)

Address (Hex.)	0	1	2	3	4	5	6	7
00	ProductID			Version	Unique Identifier			
08	Unique Identifier							Manufacturer Data
10	ManufacturerData							
18	ManufacturerData							

ProductID: Identifier for this SLRC610 product, only address 01h shall be evaluated for identifying the Product SLRC6103, address 00h and 02h shall be ignored by software.

Please note, that the silicon versions of SLRC61002 and SLRC61003 can be identified on register address 7Fh, it is not coded in the EEPROM production area.

Table 30. Product ID overview of CLRC663 family

Address 01h	Product ID
CLRC663	01h
MFRC631	C0h
MFRC630	80h
SLRC610	20h

Version: This register indicates the version of the EEPROM initialization data during production. (Identification of the Hardware version is available in the register 7Fh, not in the EEPROM Version address. The hardware information in register 7Fh is hardwired and therefore independent from any EEPROM configuration.)

Unique Identifier: Unique number code for this device

Manufacturer Data: This data is programmed during production. The content is not intended to be used by any application and might be not the same for different devices. Therefore this content needs to be considered to be undefined.

Table 31. Configuration area (Page 0)

Address (Hex.)	0	1	2	3	4	5	6	7
20	I ² C_Address	Interface	I ² C SAM_Address	DefaultProtRx	DefaultProtTx	-	TxCRCPreset	
28	RxCRCPreSet	-	-	-	-	-	-	-
30	-							
38	-							

I²C-Address: Two possibilities exist to define the address of the I²C interface. This can be done either by configuring the pins IF0, IF2 (address is then 10101xx, xx is defined by the interface pins IF0, IF2) or by writing value into the I²C address area. The selection, which of this 2-information pin configuration or EEPROM content - is used as I²C-address is done at EEPROM address 21h (Interface, bit4)

Interface This section describes the interface byte configuration.

Table 32. Interface byte

Bit	7	6	5	4	3	2	1	0
	I ² C_HSP	-	-	I2C_Address	Boundary Scan	Host		
access rights	r/w	RFU	RFU	r/w	r/w	-	-	-

Table 33. Interface bits

Bit	Symbol	Description
7	I ² C_HSP	when cleared, the high speed mode is used when set, the high speed+ mode is used (default)
6, 5	RFU	-
4	I ² C_Address	when cleared, the pins are used (default) when set, the EEPROM is used

Bit	Symbol	Description
3	Boundary Scan	when set, the boundary scan interface is ON (default) when cleared, the boundary scan is OFF
2 to 0	Host	000b - RS232 001b - I ² C 010b - SPI 011b - I ² CL 1xxb - pin selection

I²C_SAM_Address: The I²C SAM Address is always defined by the EEPROM content.

The Register Set Protocol (RSP) Area contains settings for the TX registers (16 bytes) and for the RX registers (8 bytes).

Table 34. Tx and Rx arrangements in the register set protocol area

Section								
Section 4 TX	Tx0		Tx1		TX2		Tx3	
Section 4 TX	Tx4		Tx5		TX6		TX7	
Section 4 Rx	RX0	RX1	RX2	RX3	RX4	RX5	RX6	RX7
Section 4 Rx	RX8	RX9	RX10	RX11	RX12	RX13	RX14	RX15

TxCrcPresetThe data bits are send by the analog module and are automatically extended by a CRC.

8.7.3 EEPROM initialization content LoadProtocol

The SLRC610 EEPROM is initialized at production with values which are used to reset certain registers of the SLRC610 to default settings by copying the EEprom content to the registers. Only registers or bits with "read/write" or "dynamic" access rights are initialized with this default values copied from the EEProm.

Note that the addresses used for copying reset values from EEProm to registers are dependent on the configured protocol and can be changed by the user.

Table 35. Register reset values (Hex.) (Page0)

Address	0 (8)	1 (9)	2 (A)	3 (B)	4 (C)	5 (D)	6 (E)	7 (F)
Function	Product ID			Version	Unique Identifier			
00	XX	see table 30	XX	XX	XX	XX	XX	XX
Function	Unique Identifier							Factory trim value
08	XX	XX	XX	XX	XX	XX	XX	XX
Function	TrimLFO	Factory trim values						
10	XX	XX	XX	XX	XX	XX	XX	XX
Function	Factory trim values							
18....	XX	XX	XX	XX	XX	XX	XX	XX
	Factory trim values							

Address	0 (8)	1 (9)	2 (A)	3 (B)	4 (C)	5 (D)	6 (E)	7 (F)
....38	XX	XX	XX	XX	XX	XX	XX	XX

The register reset values are configuration parameters used after startup of the IC. They can be changed to modify the default behavior of the device. In addition to this register reset values, is the possibility to load settings for various user implemented protocols. The load protocol command is used for this purpose.

Table 36. Register reset values (Hex.)(Page1 and page 2)

Address	0 (8)	1 (9)	2 (A)	3 (B)	4 (C)	5 (D)	6 (E)	7 (F)
	Command	HostCtrl	FiFoControl	WaterLevel	FiFoLength	FiFoData	IRQ0	IRQ1
40	40	00	80	05	00	00	00	00
	IRQ0En	IRQ1En	Error	Status	RxBitCtrl	RxColl	TControl	T0Control
48	10	00	00	00	00	00	00	00
	T0ReloadHi	T0ReloadLo	T0Counter ValHi	T0Counter ValLo	T1Control	T1ReloadHi	T1ReloadLo	T1Counter ValHi
50	00	80	00	00	00	00	80	00
	T1Counter ValLo	T2Control	T2ReloadHi	T2ReloadLo	T2Counter ValHi	T2Counter ValLo	T3Control	T3ReloadHi
58	00	00	00	80	00	00	00	00
	T3ReloadLo	T3Counter ValHi	T3Counter ValHi	T4Control	T4ReloadHi	T4ReloadLo	T4Counter ValHi	T4Counter ValLo
60	80	00	00	00	00	80	00	00
	DrvMode	TxAmp	DrvCon	Txl	TxCRC Preset	RxCRC Preset	TxDataNum	TxModWith
68	86	15	11	06	18	18	08	27
	TxSym10 BurstLen	TxWaitCtrl	TxWaitLo	FrameCon	RxSofD	RxCtrl	RxWait	RxThres hold
70	00	C0	12	CF	00	04	90	3F
	Rcv	RxAAna	RFU	SerialSpeed	LFO_trimm	PLL_Ctrl	PLL_Div	LPCD_QMin
78	12	0A	00	7A	80	04	20	48
	LPCD_ QMax	LPCD_I Min	LPCD_ result_I	LPCD_ result_Q	PadEn	PadOut	PadIn	SigOut
80	12	88	00	00	00	00	00	00
	TxBitMod	RFU	TxDataCon	TxDataMod	TxSymFreq	TxSym0H	TySym0L	TxSym1H
88	20	xx	04	50	40	00	00	00
	TxSym1L	TxSym2	TxSym3	TxSym10Le ngth	TxSym32Le ngth	TxSym32Bu rstCtrl	TxSym10M od	TxSym32M od
90	0x00	0x00	0x00	0x00	0x00	0x00	0x00	0x50
	RxBitMod	RxEofSym	RxSyncValH	RxSyncValL	RxSyncMod	RxMod	RXCorr	FabCal

Address	0 (8)	1 (9)	2 (A)	3 (B)	4 (C)	5 (D)	6 (E)	7 (F)
98	0x02	0x00	0x00	0x01	0x00	0x08	0x08	0xB2

8.8 Clock generation

8.8.1 Crystal oscillator

The clock applied to the SLRC610 acts as time basis for generation of the carrier sent out at TX and for the quadrature mixer I and Q clock generation as well as for the coder and decoder of the synchronous system. Therefore stability of the clock frequency is an important factor for proper performance. To obtain highest performance, clock jitter has to be as small as possible. This is best achieved by using the internal oscillator buffer with the recommended circuitry.

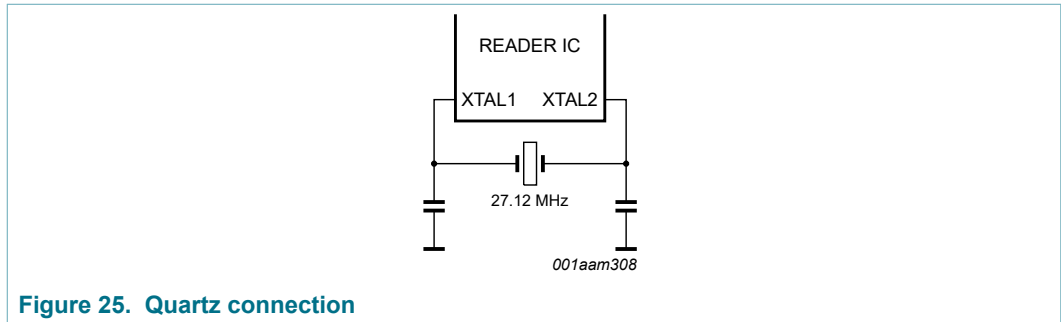

Figure 25. Quartz connection

Table 37. Crystal requirements recommendations

Symbol	Parameter	Conditions	Min	Typ	max	Unit
f_{xtal}	crystal frequency		-	27.12	-	MHz
$\Delta f_{xtal}/f_{xtal}$	relative crystal frequency variation		-250	-	+250	ppm
ESR	equivalent series resistance		-	50	100	Ω
C_L	load capacitance		-	10	-	pF
P_{xtal}	crystal power dissipation		-	50	100	μ W

8.8.2 IntegerN PLL clock line

The SLRC610 is able to provide a clock with configurable frequency at CLKOUT from 1 MHz to 24 MHz (PLL_Ctrl and PLL_DIV). There it can serve as a clock source to a microcontroller which avoids the need of a second crystal oscillator in the reader system. Clock source for the IntegerN-PLL is the 27.12 MHz crystal oscillator.

Two dividers are determining the output frequency. First a feedback integer-N divider configures the VCO frequency to be $N \times f_{in}/2$ (control signal pll_set_divfb). As supported Feedback Divider Ratios are 23, 27 and 28, VCO frequencies can be $23 \times f_{in} / 2$ (312 MHz), $27 \times f_{in} / 2$ (366 MHz) and $28 \times f_{in} / 2$ (380 MHz).

The VCO frequency is divided by a factor which is defined by the output divider (pll_set_divout). [Table 37 "Divider values for selected frequencies using the integerN PLL"](#) shows the accuracy achieved for various frequencies (integer multiples of 1 MHz and some typical RS232 frequencies) and the divider ratios to be used. The register bit ClkOutEn enables the clock at CLKOUT pin.

The following formula can be used to calculate the output frequency:

$$f_{out} = 13.56 \text{ MHz} \times \text{PLLDiv_FB} / \text{PLLDiv_Out}$$

Table 38. Divider values for selected frequencies using the integerN PLL

Frequency [MHz]	4	6	8	10	12	20	24	1.8432	3.6864
PLLDiv_FB	23	27	23	28	23	28	23	28	28
PLLDiv_Out	78	61	39	38	26	19	16	206	103
accuracy [%]	0.04	0.03	0.04	0.08	0.04	0.08	0.04	0.01	0.01

8.8.3 Low Frequency Oscillator (LFO)

The SLRC610 family implements an Low-Frequency Oscillator (LFO). Timer T4 can be configured to use a clock generated by this LFO as input clock, and can be configured as wakeup counter. As wakeup counter, the timer T4 allows to wake up the system in regular time intervals which allows to design a reader that is regularly polling for card presence or implements a low-power card detection (LPCD).

The LFO is trimmed during chip production to run at 16 kHz. Unless a high accuracy of the LFO is required by the application, and the device is operated in an environment with changing ambient temperatures, trimming of the LFO is not required. For a typical application making use of the LFO for wake-up from power saving mode, the trim value set during production can be used.

Optional trimming to achieve a higher accuracy of the 16 kHz LFO clock is supported by a digital state machine which compares LFO-clock to a reference clock generated by the connected 27.12Mhz crystal. As reference clock frequency for trimming of the LFO, a 13.56 MHz clock (27.12Mhz divided by 2) input clock to one of the timers T0,T1,T2 or T3 is used.

One of the timers T0,T1,T2,T3 with an input clock of 13,56 MHz crystal clock is used to count one clock period of the LFO. For an LFO Clock running at 16KHz this would result in 848 wakeup timer clocks of timer Tx (T0, T1, T2, T3). Therefore, the timer count value Tx at the end of a trimming cycle is expected to be 176 (wakeup timer is counting down: 1023-848=175, +/- 1 tolerance is accepted). The trim cycle is executed once in the T4 timer cycle. Therefore the T4 autoloading value shall be bigger than 0x05 to ensure that one trimming cycle takes place before T4 expires. The Tx timer value is reloaded to 1023 during the start of an Auto trim cycle. This happens every time, once after the T4 timer underflows.

At the end of each trim cycle, the timer value is checked:

- Timer Tx value < 174: LFO Frequency is too low and the trim value is incremented by 1 on T4 Timer event
- Timer Tx value > 176: LFO Frequency is too high and the trim value is decremented by 1 on T4 Timer event
- Timer Tx value is within 174 and 176: LFO Frequency = 16 KHz and trimming procedure is stopped

The cycle proceeds until the autotrim function is stopped (Timer Tx value is within 174 and 176).

In addition, the trimming cycle can be aborted by sending an IDLE Command from the host to cancel the current command execution. T3 is not allowed to be used in case T4AutoLPCD is set in parallel. It is not required to configure a TXStart condition with underflow. The T0/1/2/3 timer will typically not underflow. It may happen if the LPO clock is very slow, but it is not required to take an action to generate this event.

8.9 Power management

8.9.1 Supply concept

The SLRC610 is supplied by V_{DD} (Supply Voltage), $PVDD$ (Pad Supply) and $TVDD$ (Transmitter Power Supply). These three voltages are independent from each other.

To connect the SLRC610 to a Microcontroller supplied by 3.3 V, $PVDD$ and V_{DD} shall be at a level of 3.3 V, $TVDD$ can be in a range from 3.3 V to 5.0 V. A higher supply voltage at $TVDD$ will result in a higher field strength.

Independent of the voltage it is recommended to buffer these supplies with blocking capacitances close to the terminals of the package. V_{DD} and $PVDD$ are recommended to be blocked with a capacitor of 100 nF min, $TVDD$ is recommended to be blocked with 2 capacitors, 100 nF parallel to 1.0 μ F

$AVDD$ and $DVDD$ are not supply input pins. They are output pins and shall be connected to blocking capacitors 470 nF each.

8.9.2 Power reduction mode

8.9.2.1 Power-down

A hard power-down is enabled with HIGH level on pin PDOWN. This turns off the internal 1.8 V voltage regulators for the analog and digital core supply as well as the oscillator. All digital input buffers are separated from the input pads and clamped internally (except pin PDOWN itself). The output pins are switched to high impedance. HardPowerDown is performing a reset of the IC. All registers will be reset, the Fifo will be cleared.

To leave the power-down mode the level at the pin PDOWN as to be set to LOW. This will start the internal start-up sequence.

8.9.2.2 Standby mode

The standby mode is entered immediately after setting the bit PowerDown in the register Command. All internal current sinks are switched off. Voltage references and voltage regulators will be set into stand-by mode.

In opposition to the power-down mode, the digital input buffers are not separated by the input pads and keep their functionality. The digital output pins do not change their state.

During standby mode, all registers values, the FIFO's content and the configuration itself will keep its current content.

To leave the standby mode the bit PowerDown in the register Command is cleared. This will trigger the internal start-up sequence. The reader IC is in full operation mode again when the internal start-up sequence is finalized (the typical duration is 15 us).

A value of 55h must be sent to the SLRC610 using the RS232 interface to leave the standby mode. This is must at RS232, but cannot be used for the I²C/SPI interface. Then read accesses shall be performed at address 00h until the device returns the content of this address. The return of the content of address 00h indicates that the device is ready to receive further commands and the internal start-up sequence is finalized.

8.9.2.3 Modem off mode

When the ModemOff bit in the register Control is set the antenna transmitter and the receiver are switched off.

To leave the modem off mode clears the ModemOff bit in the register Control.

8.9.3 Low-Power Card Detection (LPCD)

The low-power card detection is an energy saving mode in which the SLRC610 is not fully powered permanently.

The LPCD works in two phases. First the standby phase is controlled by the wake-up counter (WUC), which defines the duration of the standby of the SLRC610. Second phase is the detection-phase. In this phase the values of the I and Q channel are detected and stored in the register map. (LPCD_I_Result, LPCD_Q_Result). This time period can be handled with Timer3. The value is compared with the min/max values in the registers (LPCD_IMin, LPCD_IMax; LPCD_QMin, LPCD_QMax). If it exceeds the limits, a LPCDIRQ is raised.

After the command LPCD the standby of the SLRC610 is activated, if selected. The wake-up Timer4 can activate the system after a given time. For the LPCD it is recommended to set T4AutoWakeUp and T4AutoRestart, to start the timer and then go to standby. If a card is detected the communication can be started. If T4AutoWakeUp is not set, the IC will not enter Standby mode in case no card is detected.

8.9.4 Reset and start-up time

A 10 μs constant high level at the PDOWN pin starts the internal reset procedure.

The following figure shows the internal voltage regulator:

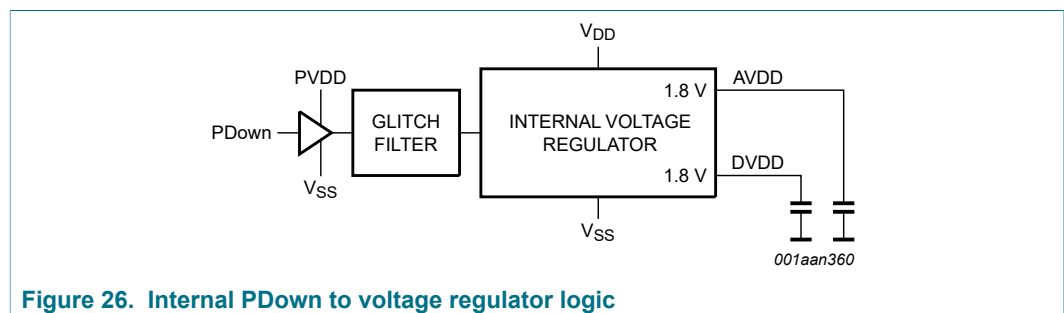

Figure 26. Internal PDown to voltage regulator logic

When the SLRC610 has finished the reset phase and the oscillator has entered a stable working condition the IC is ready to be used. A typical duration before the IC is ready to receive commands after the reset had been released is 2.5ms.

8.10 Command set

8.10.1 General

The behavior is determined by a state machine capable to perform a certain set of commands. By writing a command-code to the command register the command is executed.

Arguments and/or data necessary to process a command, are exchanged via the FIFO buffer.

- Each command that needs a certain number of arguments will start processing only when it has received the correct number of arguments via the FIFO buffer.
- The FIFO buffer is not cleared automatically at command start. It is recommended to write the command arguments and/or the data bytes into the FIFO buffer and start the command afterwards.
- Each command may be stopped by the host by writing a new command code into the command register e.g.: the Idle-Command.

8.10.2 Command set overview

Table 39. Command set

Command	No.	Parameter (bytes)	Short description
Idle	00h	-	no action, cancels current command execution
LPCD	01h	-	low-power card detection
AckReq	04h	-	performs a query, an Ack and a Req-Rn for ISO/IEC 18000-3 mode 3/ EPC Class-1 HF
Receive	05h	-	activates the receive circuit
Transmit	06h	bytes to send: byte1, byte2,....	transmits data from the FIFO buffer
Transceive	07h	bytes to send: byte1, byte2,....	transmits data from the FIFO buffer and automatically activates the receiver after transmission finished
WriteE2	08h	addressH, addressL, data;	gets one byte from FIFO buffer and writes it to the internal EEPROM
WriteE2Page	09h	(page Address), data0, [data1 ..data63];	gets up to 64 bytes (one EEPROM page) from the FIFO buffer and writes it to the EEPROM
ReadE2	0Ah	addressH, address L, length;	reads data from the EEPROM and copies it into the FIFO buffer
LoadReg	0Ch	(EEPROM addressH), (EEPROM addressL), RegAdr, (number of Register to be copied);	reads data from the internal EEPROM and initializes the SLRC610 registers. EEPROM address needs to be within EEPROM sector 2
LoadProtocol	0Dh	(Protocol number RX), (Protocol number TX);	reads data from the internal EEPROM and initializes the SLRC610 registers needed for a Protocol change
ReadRNR	1Ch	-	Copies bytes from the Random Number generator into the FIFO until the FiFo is full
Soft Reset	1Fh	-	resets the SLRC610

8.10.3 Command functionality

8.10.3.1 Idle command

Command (00h);

This command indicates that the SLRC610 is in idle mode. This command is also used to terminate the actual command.

8.10.3.2 LPCD command

Command (01h);

This command performs a low-power card detection and/or an automatic trimming of the LFO. After wakeup from standby, the values of the sampled I and Q channels are compared with the min/max threshold values in the registers. If it exceeds the limits, an LPCD_IRQ will be raised. After the LPCD command the standby is activated, if selected.

8.10.3.3 AckReq command

Command (04h);

Performs a Query (Full command must be written into the FIFO); a Ack and a ReqRn command. All answers to the command will be written into the FIFO. The error flag is copied after the answer into the FIFO.

This command terminates automatically and the then active state is idle.

8.10.3.4 Receive command

Command (05h);

The SLRC610 activates the receiver path and waits for any data stream to be received, according to its register settings. The registers must be set before starting this command according to the used protocol and antenna configuration. The correct settings have to be chosen before starting the command.

This command terminates automatically when the received data stream ends. This is indicated either by the end of frame pattern or by the length byte depending on the selected framing and speed.

8.10.3.5 Transmit command

Command (06h); data to transmit

The content of the FIFO is transmitted immediately after starting the command. Before transmitting the FIFO all relevant registers have to be set to transmit data.

This command terminates automatically when the FIFO gets empty. It can be terminated by any other command written to the command register.

8.10.3.6 Transceive command

Command (07h); data to transmit

This command transmits data from FIFO buffer and automatically activates the receiver after a transmission is finished.

Each transmission process starts by writing the command into CommandReg.

Remark: If the bit RxMultiple in register RxModeReg is set to logic 1, this command will never leave the receiving state, because the receiving will not be cancelled automatically.

8.10.3.7 WriteE2 command

Command (08h), Parameter1 (addressH), Parameter2 (addressL), Parameter3 (data);

This command writes one byte into the EEPROM. If the FIFO contains no data, the command will wait until the data is available.

Abort condition: Address-parameter outside of allowed range 0x00 – 0x7F.

8.10.3.8 WriteE2PAGE command

Command (09h), Parameter1 (page address), Parameter2..63 (data0, data1...data63);

This command writes up to 64 bytes into the EEPROM. The addresses are not allowed to wrap over a page border. If this is the case, this additional data be ignored and stays in the fifo. The programming starts after 64 bytes are read from the FIFO or the FIFO is empty.

Abort condition: Insufficient parameters in FIFO; Page address parameter outside of range 0x00 – 0x7F.

8.10.3.9 ReadE2 command

Command (0Ah), Parameter1 (addressH), Parameter2 (addressL), Parameter3 (length);

Reads up to 256 bytes from the EEPROM to the FIFO. If a read operation exceeds the address 1FFFh, the read operation continues from address 0000h.

Abort condition: Insufficient parameter in FIFO; Address parameter outside of range.

8.10.3.10 LoadReg command

Command (0Ch), Parameter1 (EEPROM addressH),Parameter2 (EEPROM addressL), Parameter3 (RegAdr), Parameter4 (number);

Read a defined number of bytes from the EEPROM and copies the value into the Register set, beginning at the given address RegAdr.

Abort condition: Insufficient parameter in FIFO; Address parameter outside of range.

8.10.3.11 LoadProtocol command

Command (0Dh), Parameter1 (Protocol number RX), Parameter2 (Protocol number TX);

Reads out the EEPROM Register Set Protocol Area and overwrites the content of the Rx- and Tx- related registers. These registers are important for a Protocol selection.

Abort condition: Insufficient parameter in FIFO

Table 40. Predefined protocol overview RX^[1]

Protocol Number (decimal)	Protocol	Receiver speed [kbits/s]	Receiver Coding
00	ISO/IEC15693	26	SSC
01	ISO/IEC15693	52	SSC
02	ISO/IEC15693	26	DSC
03	EPC/UID	26	SSC
04	ISO/IEC 18000-3 mode 3/ EPC Class-1 HF	212	2/424
05	ISO/IEC 18000-3 mode 3/ EPC Class-1 HF	106	4/424

Protocol Number (decimal)	Protocol	Receiver speed [kbits/s]	Receiver Coding
06	ISO/IEC 18000-3 mode 3/ EPC Class-1 HF	424	2/848
07	ISO/IEC 18000-3 mode 3/ EPC Class-1 HF	212	4/848

[1] For more protocol details please refer to [Section 7 "Functional description"](#).

Table 41. Predefined protocol overview TX^[1]

Protocol Number (decimal)	Protocol	Transmitter speed [kbits/s]	Transmitter Coding
00	ISO/IEC15693	26	1/4
01	ISO/IEC15693	26	1/4
02	ISO/IEC15693	1,66	1/256
03	EPC/UID	53	Unitray
04	ISO/IEC 18000-3 mode 3/ EPC Class-1 HF		based on Tari value, ASK, PIE
05	ISO/IEC 18000-3 mode 3/ EPC Class-1 HF		based on Tari value, ASK, PIE
06	ISO/IEC 18000-3 mode 3/ EPC Class-1 HF		based on Tari value, ASK, PIE
07	ISO/IEC 18000-3 mode 3/ EPC Class-1 HF		based on Tari value, ASK, PIE

[1] For more protocol details please refer to [Section 7 "Functional description"](#).

8.10.3.12 GetRNR command

Command (1Ch);

This command is reading Random Numbers from the random number generator of the SLRC610. The Random Numbers are copied to the FIFO until the FIFO is full.

8.10.3.13 SoftReset command

Command (1Fh);

This command is performing a soft reset. Triggered by this command all the default values for the register setting will be read from the EEPROM and copied into the register set.

9 SLRC610 registers

9.1 Register bit behavior

Depending on the functionality of a register, the access conditions to the register can vary. In principle, bits with same behavior are grouped in common registers. The access conditions are described in the following table: 5 m

Table 42. Behavior of register bits and their designation

Abbreviation	Behavior	Description
r/w	read and write	These bits can be written and read via the host interface. Since they are used only for control purposes, the content is not influenced by the state machines but can be read by internal state machines.
dy	dynamic	These bits can be written and read via the host interface. They can also be written automatically by internal state machines, for example Command register changes its value automatically after the execution of the command.
r	read only	These register bits indicate hold values which are determined by internal states only.
w	write only	Reading these register bits always returns zero.
RFU	-	These bits are reserved for future use and must not be changed. In case of a required write access, it is recommended to write a logic 0.

Table 43. SLRC610 registers overview

Address	Register name	Function
00h	Command	Starts and stops command execution
01h	HostCtrl	Host control register
02h	FIFOControl	Control register of the FIFO
03h	WaterLevel	Level of the FIFO underflow and overflow warning
04h	FIFOLength	Length of the FIFO
05h	FIFOData	Data In/Out exchange register of FIFO buffer
06h	IRQ0	Interrupt register 0
07h	IRQ1	Interrupt register 1
08h	IRQ0En	Interrupt enable register 0
09h	IRQ1En	Interrupt enable register 1
0Ah	Error	Error bits showing the error status of the last command execution
0Bh	Status	Contains status of the communication
0Ch	RxBitCtrl	Control register for anticollision adjustments for bit oriented protocols
0Dh	RxColl	Collision position register
0Eh	TControl	Control of Timer 0..3

Address	Register name	Function
0Fh	T0Control	Control of Timer0
10h	T0ReloadHi	High register of the reload value of Timer0
11h	T0ReloadLo	Low register of the reload value of Timer0
12h	T0CounterValHi	Counter value high register of Timer0
13h	T0CounterValLo	Counter value low register of Timer0
14h	T1Control	Control of Timer1
15h	T1ReloadHi	High register of the reload value of Timer1
16h	T1ReloadLo	Low register of the reload value of Timer1
17h	T1CounterValHi	Counter value high register of Timer1
18h	T1CounterValLo	Counter value low register of Timer1
19h	T2Control	Control of Timer2
1Ah	T2ReloadHi	High byte of the reload value of Timer2
1Bh	T2ReloadLo	Low byte of the reload value of Timer2
1Ch	T2CounterValHi	Counter value high byte of Timer2
1Dh	T2CounterValLo	Counter value low byte of Timer2
1Eh	T3Control	Control of Timer3
1Fh	T3ReloadHi	High byte of the reload value of Timer3
20h	T3ReloadLo	Low byte of the reload value of Timer3
21h	T3CounterValHi	Counter value high byte of Timer3
22h	T3CounterValLo	Counter value low byte of Timer3
23h	T4Control	Control of Timer4
24h	T4ReloadHi	High byte of the reload value of Timer4
25h	T4ReloadLo	Low byte of the reload value of Timer4
26h	T4CounterValHi	Counter value high byte of Timer4
27h	T4CounterValLo	Counter value low byte of Timer4
28h	DrvMode	Driver mode register
29h	TxAmp	Transmitter amplifier register
2Ah	DrvCon	Driver configuration register
2Bh	TxI	Transmitter register
2Ch	TxCrcPreset	Transmitter CRC control register, preset value
2Dh	RxCrcPreset	Receiver CRC control register, preset value
2Eh	TxDataNum	Transmitter data number register
2Fh	TxModWidth	Transmitter modulation width register
30h	TxSym10BurstLen	Transmitter symbol 1 + symbol 0 burst length register
31h	TXWaitCtrl	Transmitter wait control
32h	TxWaitLo	Transmitter wait low
33h	FrameCon	Transmitter frame control

Address	Register name	Function
34h	RxSofD	Receiver start of frame detection
35h	RxCtrl	Receiver control register
36h	RxWait	Receiver wait register
37h	RxThreshold	Receiver threshold register
38h	Rcv	Receiver register
39h	RxAana	Receiver analog register
3Ah	RFU	No function implemented for SLRC61002
	LPCD_Options	For SLRC61003: Options for LPCD configuration
3Bh	SerialSpeed	Serial speed register
3Ch	LFO_Trimm	Low-power oscillator trimming register
3Dh	PLL_Ctrl	IntegerN PLL control register, for microcontroller clock output adjustment
3Eh	PLL_DivOut	IntegerN PLL control register, for microcontroller clock output adjustment
3Fh	LPCD_QMin	Low-power card detection Q channel minimum threshold
40h	LPCD_QMax	Low-power card detection Q channel maximum threshold
41h	LPCD_I_Min	Low-power card detection I channel minimum threshold
42h	LPCD_I_Result	Low-power card detection I channel result register
43h	LPCD_Q_Result	Low-power card detection Q channel result register
44h	PadEn	PIN enable register
45h	PadOut	PIN out register
46h	PadIn	PIN in register
47h	SigOut	Enables and controls the SIGOUT Pin
48h	TxBitMod	Transmitter bit mode register
49h	RFU	-
4Ah	TxDDataCon	Transmitter data configuration register
4Bh	TxDDataMod	Transmitter data modulation register
4Ch	TxSymFreq	Transmitter symbol frequency
4Dh	TxSym0H	Transmitter symbol 0 high register
4Eh	TxSym0L	Transmitter symbol 0 low register
4Fh	TxSym1H	Transmitter symbol 1 high register
50h	TxSym1L	Transmitter symbol 1 low register
51h	TxSym2	Transmitter symbol 2 register
52h	TxSym3	Transmitter symbol 3 register
53h	TxSym10Len	Transmitter symbol 1 + symbol 0 length register
54h	TxSym32Len	Transmitter symbol 3 + symbol 2 length register
55h	TxSym10BurstCtrl	Transmitter symbol 1 + symbol 0 burst control register
56h	TxSym10Mod	Transmitter symbol 1 + symbol 0 modulation register
57h	TxSym32Mod	Transmitter symbol 3 + symbol 2 modulation register

Address	Register name	Function
58h	RxBitMod	Receiver bit modulation register
59h	RxEofSym	Receiver end of frame symbol register
5Ah	RxSyncValH	Receiver synchronisation value high register
5Bh	RxSyncValL	Receiver synchronisation value low register
5Ch	RxSyncMod	Receiver synchronisation mode register
5Dh	RxMod	Receiver modulation register
5Eh	RxCorr	Receiver correlation register
5Fh	FabCal	Calibration register of the receiver, calibration performed at production
48h-5Fh	RFU	-
7Fh	Version	Version and subversion register

9.2 Command configuration

9.2.1 Command

Starts and stops command execution.

Table 44. Command register (address 00h)

Bit	7	6	5	4	3	2	1	0
Symbol	Standby	Modem Off	RFU	Command				
Access rights	dy	r/w	-	dy				

Table 45. Command bits

Bit	Symbol	Description
7	Standby	Set to 1, the IC is entering power-down mode.
6	ModemOff	Set to logic 1, the receiver and the transmitter circuit is powering down.
5	RFU	-
4 to 0	Command	Defines the actual command for the SLRC610.

9.3 SAM configuration register

9.3.1 HostCtrl

Via the HostCtrl Register the interface access right can be controlled

Table 46. HostCtrl register (address 01h);

Bit	7	6	5	4	3	2	1	0
Symbol	RegEn	BusHost	BusSAM	RFU	SAMInterface	SAMInterface	RFU	RFU

Bit	7	6	5	4	3	2	1	0
Access rights	dy	r/w	r/w	-	r/w	r/w	-	-

Table 47. HostCtrl bits

Bit	Symbol	Description
7	RegEn	If this bit is set to logic 1, the register HostCtrl_reg can be changed at the next register access. The next write access clears this bit automatically.
6	BusHost	Set to logic 1, the bus is controlled by the host. This bit cannot be set together with the bit BusSAM. This bit can only be set if the bit RegEn is previously set.
5	BusSAM	Set to logic 1, the bus is controlled by the SAM. This bit cannot be set together with BusHost. This bit can only be set if the bit RegEn is previously set.
4	RFU	-
3 to 2	SAMInterface	0h: SAM Interface switched off 1h: SAM Interface SPI active 2h: SAM Interface I ² CL active 3h: SAM Interface I ² C active
1 to 0	RFU	-

9.4 FIFO configuration register

9.4.1 FIFOControl

FIFOControl defines the characteristics of the FIFO

Table 48. FIFOControl register (address 02h);

Bit	7	6	5	4	3	2	1	0
Symbol	FIFOSize	HiAlert	LoAlert	FIFOFlush	RFU	WaterLevelExtBit	FIFOLengthExtBits	
Access rights	r/w	r	r	w	-	r/w	r	

Table 49. FIFOControl bits

Bit	Symbol	Description
7	FIFOSize	Set to logic 1, FIFO size is 255 bytes; Set to logic 0, FIFO size is 512 bytes. It is recommended to change the FIFO size only, when the FIFO content had been cleared.
6	HiAlert	Set to logic 1, when the number of bytes stored in the FIFO buffer fulfils the following equation: $HiAlert = (FIFOSize - FIFOLength) \leq WaterLevel$

Bit	Symbol	Description
5	LoAlert	Set to logic 1, when the number of bytes stored in the FIFO buffer fulfils the following conditions: LoAlert =1 if FIFOLength <= WaterLevel
4	FIFOFlush	Set to logic 1 clears the FIFO buffer. Reading this bit will always return 0
3	RFU	-
2	WaterLevelExtBit	Defines the bit 8 (MSB) for the waterlevel (extension of register WaterLevel). This bit is only evaluated in the 512-byte FIFO mode. Bits 7..0 are defined in register WaterLevel.
1 to 0	FIFOLengthExtBits	Defines the bit9 (MSB) and bit8 for the FIFO length (extension of FIFOLength). These two bits are only evaluated in the 512-byte FIFO mode, The bits 7..0 are defined in register FIFOLength.

9.4.2 WaterLevel

Defines the level for FIFO under- and overflow warning levels. This register is extended by 1 bit in FIFOControl in case the 512-byte FIFO mode is activated by setting bit FIFOControl.FIFOSize.

Table 50. WaterLevel register (address 03h);

Bit	7	6	5	4	3	2	1	0
Symbol	WaterLevelBits							
Access rights	r/w	r/w	r/w	r/w	r/w	r/w	r/w	r/w

Table 51. WaterLevel bits

Bit	Symbol	Description
7 to 0	WaterLevelBits	<p>Sets a level to indicate a FIFO-buffer state which can be read from bits HighAlert and LowAlert in the FifoControl. In 512-byte FIFO mode, the register is extended by bit WaterLevelExtBit in the FIFOControl. This functionality can be used to avoid a FIFO buffer overflow or underflow:</p> <p>The bit HiAlert bit in FIFO Control is read logic 1, if the number of bytes in the FIFO-buffer is equal or less than the number defined by the waterlevel configuration.</p> <p>The bit LoAlert bit in FIFO control is read logic 1, if the number of bytes in the FIFO buffer is equal or less than the number defined by the waterlevel configuration.</p> <p>Note: For the calculation of HiAlert and LoAlert see register description of these bits (Section 8.4.1 "FIFOControl").</p>

9.4.3 FIFOLength

Number of bytes in the FIFO buffer. In 512-byte mode this register is extended by FIFOControl.FifoLength.

Table 52. FIFOLength register (address 04h); reset value: 00h

Bit	7	6	5	4	3	2	1	0
Symbol	FIFOLength							
Access rights	dy							

Table 53. FIFOLength bits

Bit	Symbol	Description
7 to 0	FIFOLength	Indicates the number of bytes in the FIFO buffer. In 512-byte mode this register is extended by the bits FIFOLength in the FIFOControl register. Writing to the FIFOData register increments, reading decrements the number of available bytes in the FIFO.

9.4.4 FIFOData

In- and output of FIFO buffer. Contrary to any read/write access to other addresses, reading or writing to the FIFO address does not increment the address pointer. Writing to the FIFOData register increments, reading decrements the number of bytes present in the FIFO.

Table 54. FIFOData register (address 05h);

Bit	7	6	5	4	3	2	1	0
Symbol	FIFOData							
Access rights	dy	dy	dy	dy	dy	dy	dy	dy

Table 55. FIFOData bits

Bit	Symbol	Description
7 to 0	FIFOData	Data input and output port for the internal FIFO buffer. Refer to Section 7.5 "Buffer" .

9.5 Interrupt configuration registers

The Registers IRQ0 register and IRQ1 register implement a special functionality to avoid the unintended modification of bits.

The mechanism of changing register contents requires the following consideration: IRQ(x).Set indicates, if a set bit on position 0 to 6 shall be cleared or set. Depending on the content of IRQ(x).Set, a write of a 1 to positions 0 to 6 either clears or sets the corresponding bit. With this register the application can modify the interrupt status which is maintained by the SLRC610.

Bit 7 indicates, if the intended modification is a setting or clearance of a bit. Any 1 written to a bit position 6..0 will trigger the setting or clearance of this bit as defined by bit 7. Example: writing FFh sets all bits 6..0, writing 7Fh clears all bits 6..0 of the interrupt request register

9.5.1 IRQ0 register

Interrupt request register 0.

Table 56. IRQ0 register (address 06h); reset value: 00h

Bit	7	6	5	4	3	2	1	0
Symbol	Set	Hi AlertIRQ	Lo AlertIRQ	IdleIRQ	TxIRQ	RxIRQ	ErrIRQ	RxSOF IRQ
Access rights	w	dy	dy	dy	dy	dy	dy	dy

Table 57. IRQ0 bits

Bit	Symbol	Description
7	Set	1: writing a 1 to a bit position 6..0 sets the interrupt request 0: Writing a 1 to a bit position 6..0 clears the interrupt request
6	HiAlerIRQ	Set, when bit HiAlert in register Status1Reg is set. In opposition to HiAlert, HiAlertIRQ stores this event.
5	LoAlertIRQ	Set, when bit LoAlert in register Status1 is set. In opposition to LoAlert, LoAlertIRQ stores this event.
4	IdleIRQ	Set, when a command terminates by itself e.g. when the Command changes its value from any command to the Idle command. If an unknown command is started, the Command changes its content to the idle state and the bit IdleIRQ is set. Starting the Idle command by the Controller does not set bit IdleIRQ. .
3	TxIRQ	Set, when data transmission is completed, which is immediately after the last bit is sent.
2	RxIRQ	Set, when the receiver detects the end of a data stream. Note: This flag is no indication that the received data stream is correct. The error flags have to be evaluated to get the status of the reception.
1	ErrIRQ	Set, when the one of the following errors is set: FifoWrErr, FiFoOvl, ProtErr, NoDataErr, IntegErr.
0	RxSOFIrq	Set, when a SOF or a subcarrier is detected.

9.5.2 IRQ1 register

Interrupt request register 1.

Table 58. IRQ1 register (address 07h)

Bit	7	6	5	4	3	2	1	0
Symbol	Set	GlobalIRQ	LPCD_IRQ	Timer4IRQ	Timer3IRQ	Timer2IRQ	Timer1IRQ	Timer0IRQ
Access rights	w	dy	dy	dy	dy	dy	dy	dy

Table 59. IRQ1 bits

Bit	Symbol	Description
7	Set	1: writing a 1 to a bit position 5..0 sets the interrupt request 0: Writing a 1 to a bit position 5..0 clears the interrupt request
6	GlobalIRQ	Set, if an enabled IRQ occurs.
5	LPCD_IRQ	Set if a card is detected in Low-power card detection sequence.
4	Timer4IRQ	Set to logic 1 when Timer4 has an underflow.
3	Timer3IRQ	Set to logic 1 when Timer3 has an underflow.
2	Timer2IRQ	Set to logic 1 when Timer2 has an underflow.
1	Timer1IRQ	Set to logic 1 when Timer1 has an underflow.
0	Timer0IRQ	Set to logic 1 when Timer0 has an underflow.

9.5.3 IRQ0En register

Interrupt request enable register for IRQ0. This register allows to define if an interrupt request is processed by the SLRC610.

Table 60. IRQ0En register (address 08h)

Bit	7	6	5	4	3	2	1	0
Symbol	IRQ_Inv	Hi AlertIRQEn	LoAlertIRQEn	IdleIRQEn	TxIRQEn	RxIRQEn	ErrIRQEn	RxSOF IRQEn
Access rights	r/w	r/w	r/w	r/w	r/w	r/w	r/w	r/w

Table 61. IRQ0En bits

Bit	Symbol	Description
7	IRQ_Inv	Set to one the signal of the IRQ pin is inverted
6	Hi AlerIRQEn	Set to logic 1, it allows the High Alert interrupt Request (indicated by the bit HiAlertIRQ) to be propagated to the GlobalIRQ
5	Lo AlertIRQEn	Set to logic 1, it allows the Low Alert Interrupt Request (indicated by the bit LoAlertIRQ) to be propagated to the GlobalIRQ
4	IdleIRQEn	Set to logic 1, it allows the Idle interrupt request (indicated by the bit IdleIRQ) to be propagated to the GlobalIRQ
3	TxIRQEn	Set to logic 1, it allows the transmitter interrupt request (indicated by the bit TxIRQ) to be propagated to the GlobalIRQ
2	RxIRQEn	Set to logic 1, it allows the receiver interrupt request (indicated by the bit RxIRQ) to be propagated to the GlobalIRQ
1	ErrIRQEn	Set to logic 1, it allows the Error interrupt request (indicated by the bit ErrorIRQ) to be propagated to the GlobalIRQ
0	RxSOFIRQEn	Set to logic 1, it allows the RxSOF interrupt request (indicated by the bit RxSOFIRQ) to be propagated to the GlobalIRQ

9.5.4 IRQ1En

Interrupt request enable register for IRQ1.

Table 62. IRQ1EN register (address 09h);

Bit	7	6	5	4	3	2	1	0
Symbol	IRQPushPull	IRQPinEn	LPCD_IRQEn	Timer4 IRQEn	Timer3 IRQEn	Timer2 IRQEn	Timer1 IRQEn	Timer0 IRQEn
Access rights	r/w	r/w	r/w	r/w	r/w	r/w	r/w	r/w

Table 63. IRQ1EN bits

Bit	Symbol	Description
7	IRQPushPull	Set to 1 the IRQ-pin acts as PushPull pin, otherwise it acts as OpenDrain pin
6	IRQPinEN	Set to logic 1, it allows the global interrupt request (indicated by the bit GlobalIRQ) to be propagated to the interrupt pin
5	LPCD_IRQEN	Set to logic 1, it allows the LPCDinterrupt request (indicated by the bit LPCDIRQ) to be propagated to the GlobalIRQ
4	Timer4IRQEn	Set to logic 1, it allows the Timer4 interrupt request (indicated by the bit Timer4IRQ) to be propagated to the GlobalIRQ
3	Timer3IRQEn	Set to logic 1, it allows the Timer3 interrupt request (indicated by the bit Timer3IRQ) to be propagated to the GlobalIRQ
2	Timer2IRQEn	Set to logic 1, it allows the Timer2 interrupt request (indicated by the bit Timer2IRQ) to be propagated to the GlobalIRQ
1	Timer1IRQEn	Set to logic 1, it allows the Timer1 interrupt request (indicated by the bit Timer1IRQ) to be propagated to the GlobalIRQ
0	Timer0IRQEn	Set to logic 1, it allows the Timer0 interrupt request (indicated by the bit Timer0IRQ) to be propagated to the GlobalIRQ

9.6 Contactless interface configuration registers

9.6.1 Error

Error register.

Table 64. Error register (address 0Ah)

Bit	7	6	5	4	3	2	1	0
Symbol	EE_Err	FiFoWrErr	FIFOovl	MinFrameErr	NoDataErr	CollDet	ProtErr	IntegErr
Access rights	dy	dy	dy	dy	dy	dy	dy	dy

Table 65. Error bits

Bit	Symbol	Description
7	EE_Err	An error appeared during the last EEPROM command. For details see the descriptions of the EEPROM commands

Bit	Symbol	Description
6	FIFOWrErr	Data was written into the FIFO, during a transmission of a possible CRC, during "RxWait", "Wait for data" or "Receiving" state, or during an authentication command. The Flag is cleared when a new CL command is started. If RxMultiple is active, the flag is cleared after the error flags have been written to the FIFO.
5	FIFOovl	Data is written into the FIFO when it is already full. The data that is already in the FIFO will remain untouched. All data that is written to the FIFO after this Flag is set to 1 will be ignored.
4	Min FrameErr	A valid SOF was received, but afterwards less than 4 bits of data were received. Note: Frames with less than 4 bits of data are automatically discarded and the RxDecoder stays enabled. Furthermore no RxIRQ is set. The same is valid for less than 3 Bytes if the EMD suppression is activated Note: MinFrameErr is automatically cleared at the start of a receive or transceive command. In case of a transceive command, it is cleared at the start of the receiving phase ("Wait for data" state)
3	NoDataErr	Data should be sent, but no data is in FIFO
2	CollDet	A collision has occurred. The position of the first collision is shown in the register RxColl. Note: CollDet is automatically cleared at the start of a receive or transceive command. In case of a transceive command, it is cleared at the start of the receiving phase ("Wait for data" state). Note: If a collision is part of the defined EOF symbol, CollDet is not set to 1.
1	ProtErr	A protocol error has occurred. A protocol error can be a wrong stop bit or SOF or a wrong number of received data bytes. When a protocol error is detected, data reception is stopped. Note: ProtErr is automatically cleared at start of a receive or transceive command. In case of a transceive command, it is cleared at the start of the receiving phase ("Wait for data" state). Note: When a protocol error occurs the last received data byte is not written into the FIFO.
0	IntegErr	A data integrity error has been detected. Possible cause can be a wrong parity or a wrong CRC. In case of a data integrity error the reception is continued. Note: IntegErr is automatically cleared at start of a Receive or Transceive command. In case of a Transceive command, it is cleared at the start of the receiving phase ("Wait for data" state). Note: If the NoColl bit is set, also a collision is setting the IntegErr.

9.6.2 Status

Status register.

Table 66. Status register (address 0Bh)

Bit	7	6	5	4	3	2	1	0
Symbol	-	-	-	-	-	ComState		
Access rights	RFU	RFU	RFU	RFU	RFU	r		

Table 67. Status bits

Bit	Symbol	Description
7 to 3	-	RFU
2 to 0	ComState	ComState shows the status of the transmitter and receiver state machine:
		000b ... Idle
		001b ... TxWait
		011b ... Transmitting
		101b ... RxWait
		110b ... Wait for data
		111b ... Receiving
		100b ... not used

9.6.3 RxBitCtrl

Receiver control register.

Table 68. RxBitCtrl register (address 0Ch);

Bit	7	6	5	4	3	2	1	0
Symbol	ValuesAfterColl	RxAlign			NoColl	RxLastBits		
Access rights	r/w	r/w	r/w	r/w	r/w	w	w	w

Table 69. RxBitCtrl bits

Bit	Symbol	Description
7	ValuesAfterColl	If cleared, every received bit after a collision is replaced by a zero. This function is needed for ISO/IEC14443 anticollision
6 to 4	RxAlign	Used for reception of bit oriented frames: RxAlign defines the bit position length for the first bit received to be stored. Further received bits are stored at the following bit positions. Example: RxAlign = 0h - the LSB of the received bit is stored at bit 0, the second received bit is stored at bit position 1. RxAlign = 1h - the LSB of the received bit is stored at bit 1, the second received bit is stored at bit position 2. RxAlign = 7h - the LSB of the received bit is stored at bit 7, the second received bit is stored in the following byte at position 0. Note: If RxAlign = 0, data is received byte-oriented, otherwise bit-oriented.
3	NoColl	If this bit is set, a collision will result in an IntegErr
2 to 0	RxLastBits	Defines the number of valid bits of the last data byte received in bit-oriented communications. If zero the whole byte is valid. Note: These bits are set by the RxDecoder in a bit-oriented communication at the end of the communication. They are reset at start of reception.

9.6.4 RxColl

Receiver collision register.

Table 70. RxColl register (address 0Dh);

Bit	7	6	5	4	3	2	1	0
Symbol	CollPosValid	CollPos						
Access rights	r	r						

Table 71. RxColl bits

Bit	Symbol	Description
7	CollPos Valid	If set to 1, the value of CollPos is valid. Otherwise no collision is detected or the position of the collision is out of the range of bits CollPos.
6 to 0	CollPos	<p>These bits show the bit position of the first detected collision in a received frame (only data bits are interpreted). CollPos can only be displayed for the first 8 bytes of a data stream.</p> <p>Example:</p> <p>00h indicates a bit collision in the 1st bit 01h indicates a bit collision in the 2nd bit 08h indicates a bit collision in the 9th bit (1st bit of 2nd byte) 3Fh indicates a bit collision in the 64th bit (8th bit of the 8th byte)</p> <p>These bits shall only be interpreted in ISO/IEC 15693/ICODE SLI read/write mode if bit CollPosValid is set.</p> <p>Note: If RxBitCtrl.RxAlign is set to a value different to 0, this value is included in the CollPos.</p> <p>Example: RxAlign = 4h, a collision occurs in the 4th received bit (which is the last bit of that UID byte). The CollPos = 7h in this case.</p>

9.7 Timer configuration registers

9.7.1 TControl

Control register of the timer section.

The TControl implements a special functionality to avoid the not intended modification of bits.

Bit 3..0 indicates, which bits in the positions 7..4 are intended to be modified.

Example: writing FFh sets all bits 7..4, writing F0h does not change any of the bits 7..4

Table 72. TControl register (address 0Eh)

Bit	7	6	5	4	3	2	1	0
Symbol	T3Running	T2Running	T1Running	T0Running	T3Start StopNow	T2Start StopNow	T1Start StopNow	T0Start StopNow
Access rights	dy	dy	dy	dy	w	w	w	w

Table 73. TControl bits

Bit	Symbol	Description
7	T3Running	Indicates Timer3 is running.If the bit T3startStopNow is set/reset, this bit and the timer can be started/stopped
6	T2Running	Indicates Timer2 is running. If the bit T2startStopNow is set/reset, this bit and the timer can be started/stopped
5	T1Running	Indicates tTmer1 is running. If the bit T1startStopNow is set/reset, this bit and the timer can be started/stopped
4	T0Running	Indicates Timer0 is running. If the bit T0startStopNow is set/reset, this bit and the timer can be started/stopped
3	T3StartStop Now	The bit 7 of TControl T3Running can be modified if set
2	T2StartStop Now	The bit 6of TControl T2Running can be modified if set
1	T1StartStop Now	The bit 5of TControl T1Running can be modified if set
0	T0StartStop Now	The bit 4 of TControl T0Running can be modified if set

9.7.2 T0Control

Control register of the Timer0.

Table 74. T0Control register (address 0Fh);

Bit	7	6	5	4	3	2	1	0
Symbol	T0StopRx	-	T0Start		T0AutoRestart	-	T0CIk	
Access rights	r/w	RFU	r/w		r/w	RFU	r/w	

Table 75. T0Control bits

Bit	Symbol	Description
7	T0StopRx	If set, the timer stops immediately after receiving the first 4 bits. If cleared the timer does not stop automatically. Note: If LFO Trimming is selected by T0Start, this bit has no effect.
6	-	RFU
5 to 4	T0Start	00b: The timer is not started automatically 01 b: The timer starts automatically at the end of the transmission 10 b: Timer is used for LFO trimming without underflow (Start/Stop on PosEdge) 11 b: Timer is used for LFO trimming with underflow (Start/Stop on PosEdge)
3	T0AutoRestart	1: the timer automatically restarts its count-down from T0ReloadValue, after the counter value has reached the value zero. 0: the timer decrements to zero and stops. The bit Timer1IRQ is set to logic 1 when the timer underflows.

Bit	Symbol	Description
2	-	RFU
1 to 0	T0Clk	00 b: The timer input clock is 13.56 MHz. 01 b: The timer input clock is 211,875 kHz. 10 b: The timer input clock is an underflow of Timer2. 11 b: The timer input clock is an underflow of Timer1.

9.7.2.1 T0ReloadHi

High byte reload value of the Timer0.

Table 76. T0ReloadHi register (address 10h);

Bit	7	6	5	4	3	2	1	0
Symbol	T0Reload Hi							
Access rights	r/w							

Table 77. T0ReloadHi bits

Bit	Symbol	Description
7 to 0	T0ReloadHi	Defines the high byte of the reload value of the timer. With the start event the timer loads the value of the registers T0ReloadValHi, T0ReloadValLo. Changing this register affects the timer only at the next start event.

9.7.2.2 T0ReloadLo

Low byte reload value of the Timer0.

Table 78. T0ReloadLo register (address 11h);

Bit	7	6	5	4	3	2	1	0
Symbol	T0ReloadLo							
Access rights	r/w							

Table 79. T0ReloadLo bits

Bit	Symbol	Description
7 to 0	T0ReloadLo	Defines the low byte of the reload value of the timer. With the start event the timer loads the value of the T0ReloadValHi, T0ReloadValLo. Changing this register affects the timer only at the next start event.

9.7.2.3 T0CounterValHi

High byte of the counter value of Timer0.

Table 80. T0CounterValHi register (address 12h)

Bit	7	6	5	4	3	2	1	0
Symbol	T0CounterValHi							
Access rights	dy							

Table 81. T0CounterValHi bits

Bit	Symbol	Description
7to0	T0CounterValHi	High byte value of the Timer0. This value shall not be read out during reception.

9.7.2.4 T0CounterValLo

Low byte of the counter value of Timer0.

Table 82. T0CounterValLo register (address 13h)

Bit	7	6	5	4	3	2	1	0
Symbol	T0CounterValLo							
Access rights	dy							

Table 83. T0CounterValLo bits

Bit	Symbol	Description
7 to 0	T0CounterValLo	Low byte value of the Timer0. This value shall not be read out during reception.

9.7.2.5 T1Control

Control register of the Timer1.

Table 84. T1Control register (address 14h);

Bit	7	6	5	4	3	2	1	0
Symbol	T1StopRx	-	T1Start		T1AutoRestart	-	T1Clk	
Access rights	r/w	RFU	r/w		r/w	RFU	r/w	

Table 85. T1Control bits

Bit	Symbol	Description
7	T1StopRx	If set, the timer stops after receiving the first 4 bits. If cleared, the timer is not stopped automatically. Note: If LFO trimming is selected by T1start, this bit has no effect.
6	-	RFU

Bit	Symbol	Description
5 to 4	T1Start	00b: The timer is not started automatically 01 b: The timer starts automatically at the end of the transmission 10 b: Timer is used for LFO trimming without underflow (Start/Stop on PosEdge) 11 b: Timer is used for LFO trimming with underflow (Start/Stop on PosEdge)
3	T1AutoRestart	Set to logic 1, the timer automatically restarts its countdown from T1ReloadValue, after the counter value has reached the value zero. Set to logic 0 the timer decrements to zero and stops. The bit Timer1IRQ is set to logic 1 when the timer underflows.
2	-	RFU
1 to 0	T1Clk	00 b: The timer input clock is 13.56 MHz 01 b: The timer input clock is 211,875 kHz. 10 b: The timer input clock is an underflow of Timer0 11 b: The timer input clock is an underflow of Timer2

9.7.2.6 T1ReloadHi

High byte (MSB) reload value of the Timer1.

Table 86. T0ReloadHi register (address 15h)

Bit	7	6	5	4	3	2	1	0
Symbol	T1ReloadHi							
Access rights	r/w							

Table 87. T1ReloadHi bits

Bit	Symbol	Description
7 to 0	T1ReloadHi	Defines the high byte reload value of the Timer 1. With the start event the timer loads the value of the T1ReloadValHi and T1ReloadValLo. Changing this register affects the Timer only at the next start event.

9.7.2.7 T1ReloadLo

Low byte (LSB) reload value of the Timer1.

Table 88. T1ReloadLo register (address 16h)

Bit	7	6	5	4	3	2	1	0
Symbol	T1ReloadLo							
Access rights	r/w							

Table 89. T1ReloadValLo bits

Bit	Symbol	Description
7 to 0	T1ReloadLo	Defines the low byte of the reload value of the Timer1. Changing this register affects the timer only at the next start event.

9.7.2.8 T1CounterValHi

High byte (MSB) of the counter value of byte Timer1.

Table 90. T1CounterValHi register (address 17h)

Bit	7	6	5	4	3	2	1	0
Symbol	T1CounterValHi							
Access rights	dy							

Table 91. T1CounterValHi bits

Bit	Symbol	Description
7 to 0	T1CounterValHi	High byte of the current value of the Timer1. This value shall not be read out during reception.

9.7.2.9 T1CounterValLo

Low byte (LSB) of the counter value of byte Timer1.

Table 92. T1CounterValLo register (address 18h)

Bit	7	6	5	4	3	2	1	0
Symbol	T1CounterValLo							
Access rights	dy							

Table 93. T1CounterValLo bits

Bit	Symbol	Description
7 to 0	T1CounterValLo	Low byte of the current value of the counter 1. This value shall not be read out during reception.

9.7.2.10 T2Control

Control register of the Timer2.

Table 94. T2Control register (address 19h)

Bit	7	6	5	4	3	2	1	0
Symbol	T2StopRx	-	T2Start		T2AutoRestart	-	T2Clk	
Access rights	r/w	RFU	r/w		r/w	RFU	r/w	

Table 95. T2Control bits

Bit	Symbol	Description
7	T2StopRx	If set the timer stops immediately after receiving the first 4 bits. If cleared indicates, that the timer is not stopped automatically. Note: If LFO Trimming is selected by T2Start, this bit has no effect.
6	-	RFU
5 to 4	T2Start	00 b: The timer is not started automatically. 01 b: The timer starts automatically at the end of the transmission. 10 b: Timer is used for LFO trimming without underflow (Start/Stop on PosEdge). 11 b: Timer is used for LFO trimming with underflow (Start/Stop on PosEdge).
3	T2AutoRestart	Set to logic 1, the timer automatically restarts its countdown from T2ReloadValue, after the counter value has reached the value zero. Set to logic 0 the timer decrements to zero and stops. The bit Timer2IRQ is set to logic 1 when the timer underflows
2	-	RFU
1 to 0	T2Clk	00 b: The timer input clock is 13.56 MHz. 01 b: The timer input clock is 212 kHz. 10 b: The timer input clock is an underflow of Timer0 11b: The timer input clock is an underflow of Timer1

9.7.2.11 T2ReloadHi

High byte of the reload value of Timer2.

Table 96. T2ReloadHi register (address 1Ah)

Bit	7	6	5	4	3	2	1	0
Symbol	T2ReloadHi							
Access rights	r/w							

Table 97. T2Reload bits

Bit	Symbol	Description
7 to 0	T2ReloadHi	Defines the high byte of the reload value of the Timer2. With the start event the timer load the value of the T2ReloadValHi and T2ReloadValLo. Changing this register affects the timer only at the next start event.

9.7.2.12 T2ReloadLo

Low byte of the reload value of Timer2.

Table 98. T2ReloadLo register (address 1Bh)

Bit	7	6	5	4	3	2	1	0
Symbol	T2ReloadLo							
Access rights	r/w							

Table 99. T2ReloadLo bits

Bit	Symbol	Description
7 to 0	T2ReloadLo	Defines the low byte of the reload value of the Timer2. With the start event the timer load the value of the T2ReloadValHi and T2RelaodVaLo. Changing this register affects the timer only at the next start event.

9.7.2.13 T2CounterValHi

High byte of the counter register of Timer2.

Table 100. T2CounterValHi register (address 1Ch)

Bit	7	6	5	4	3	2	1	0
Symbol	T2CounterValHi							
Access rights	dy							

Table 101. T2CounterValHi bits

Bit	Symbol	Description
7 to 0	T2CounterValHi	High byte current counter value of Timer2. This value shall not be read out during reception.

9.7.2.14 T2CounterValLoReg

Low byte of the current value of Timer 2.

Table 102. T2CounterValLo register (address 1Dh)

Bit	7	6	5	4	3	2	1	0
Symbol	T2CounterValLo							
Access rights	dy							

Table 103. T2CounterValLo bits

Bit	Symbol	Description
7 to 0	T2CounterValLo	Low byte of the current counter value of Timer1Timer2. This value shall not be read out during reception.

9.7.2.15 T3Control

Control register of the Timer 3.

Table 104. T3Control register (address 1Eh)

Bit	7	6	5	4	3	2	1	0
Symbol	T3StopRx	-	T3Start		T3AutoRestart	-	T3Clk	
Access rights	r/w	RFU	r/w		r/w	RFU	r/w	

Table 105. T3Control bits

Bit	Symbol	Description
7	T3StopRx	If set, the timer stops immediately after receiving the first 4 bits. If cleared, indicates that the timer is not stopped automatically. Note: If LFO Trimming is selected by T3Start, this bit has no effect.
6	-	RFU
5 to 4	T3Start	00b - timer is not started automatically 01 b - timer starts automatically at the end of the transmission 10 b - timer is used for LFO trimming without underflow (Start/Stop on PosEdge) 11 b - timer is used for LFO trimming with underflow (Start/Stop on PosEdge).
3	T3AutoRestart	Set to logic 1, the timer automatically restarts its countdown from T3ReloadValue, after the counter value has reached the value zero. Set to logic 0 the timer decrements to zero and stops. The bit Timer1IRQ is set to logic 1 when the timer underflows.
2	-	RFU
1 to 0	T3Clk	00 b - the timer input clock is 13.56 MHz. 01 b - the timer input clock is 211,875 kHz. 10 b - the timer input clock is an underflow of Timer0 11 b - the timer input clock is an underflow of Timer1

9.7.2.16 T3ReloadHi

High byte of the reload value of Timer3.

Table 106. T3ReloadHi register (address 1Fh);

Bit	7	6	5	4	3	2	1	0
Symbol	T3ReloadHi							
Access rights	r/w							

Table 107. T3ReloadHi bits

Bit	Symbol	Description
7 to 0	T3ReloadHi	Defines the high byte of the reload value of the Timer3. With the start event the timer load the value of the T3ReloadValHi and T3ReloadValLo. Changing this register affects the timer only at the next start event.

9.7.2.17 T3ReloadLo

Low byte of the reload value of Timer3.

Table 108. T3ReloadLo register (address 20h)

Bit	7	6	5	4	3	2	1	0
Symbol	T3ReloadLo							
Access rights	r/w							

Table 109. T3ReloadLo bits

Bit	Symbol	Description
7 to 0	T3ReloadLo	Defines the low byte of the reload value of Timer3. With the start event the timer load the value of the T3ReloadValHi and T3RelaodValLo. Changing this register affects the timer only at the next start event.

9.7.2.18 T3CounterValHi

High byte of the current counter value the 16-bit Timer3.

Table 110. T3CounterValHi register (address 21h)

Bit	7	6	5	4	3	2	1	0
Symbol	T3CounterValHi							
Access rights	dy							

Table 111. T3CounterValHi bits

Bit	Symbol	Description
7 to 0	T3CounterValHi	High byte of the current counter value of Timer3. This value shall not be read out during reception.

9.7.2.19 T3CounterValLo

Low byte of the current counter value the 16-bit Timer3.

Table 112. T3CounterValLo register (address 22h)

Bit	7	6	5	4	3	2	1	0
Symbol	T3CounterValLo							
Access rights	dy							

Table 113. T3CounterValLo bits

Bit	Symbol	Description
7 to 0	T3CounterValLo	Low byte current counter value of Timer3. This value shall not be read out during reception.

9.7.2.20 T4Control

The wake-up timer T4 activates the system after a given time. If enabled, it can start the low power card detection function.

Table 114. T4Control register (address 23h)

Bit	7	6	5	4	3	2	1	0
Symbol	T4Running	T4StartStopNow	T4AutoTrimm	T4AutoLPCD	T4AutoRestart	T4AutoWakeUp	T4Clk	

Bit	7	6	5	4	3	2	1	0
Access rights	dy	w	r/w	r/w	r/w	r/w	r/w	

Table 115. T4Control bits

Bit	Symbol	Description
7	T4Running	Shows if the timer T4 is running. If the bit T4StartStopNow is set, this bit and the timer T4 can be started/stopped.
6	T4StartStopNow	if set, the bit T4Running can be changed.
5	T4AutoTrimm	If set to one, the timer activates an LFO trimming procedure when it underflows. For the T4AutoTrimm function, at least one timer (T0 to T3) has to be configured properly for trimming (T3 is not allowed if T4AutoLPCD is set in parallel).
4	T4AutoLPCD	If set to one, the timer activates a low-power card detection sequence. If a card is detected an interrupt request is raised and the system remains active if enabled. If no card is detected the SLRC610 enters the Power down mode if enabled. The timer is automatically restarted (no gap). Timer 3 is used to specify the time where the RF field is enabled to check if a card is present. Therefore you may not use Timer 3 for T4AutoTrimm in parallel.
3	T4AutoRestart	Set to logic 1, the timer automatically restarts its countdown from T4ReloadValue, after the counter value has reached the value zero. Set to logic 0 the timer decrements to zero and stops. The bit Timer4IRQ is set to logic 1 at timer underflow.
2	T4AutoWakeUp	If set, the SLRC610 wakes up automatically, when the timer T4 has an underflow. This bit has to be set if the IC should enter the Power down mode after T4AutoTrimm and/or T4AutoLPCD is finished and no card has been detected. If the IC should stay active after one of these procedures this bit has to be set to 0.
1 to 0	T4Clk	00b - the timer input clock is the LFO clock 01b - the timer input clock is the LFO clock/8 10b - the timer input clock is the LFO clock/16 11b - the timer input clock is the LFO clock/32

9.7.2.21 T4ReloadHi

High byte of the reload value of the 16-bit timer 4.

Table 116. T4ReloadHi register (address 24h)

Bit	7	6	5	4	3	2	1	0
Symbol	T4ReloadHi							
Access rights	r/w							

Table 117. T4ReloadHi bits

Bit	Symbol	Description
7 to 0	T4ReloadHi	Defines high byte of the for the reload value of timer 4. With the start event the timer 4 loads the T4ReloadVal. Changing this register affects the timer only at the next start event.

9.7.2.22 T4ReloadLo

Low byte of the reload value of the 16-bit timer 4.

Table 118. T4ReloadLo register (address 25h)

Bit	7	6	5	4	3	2	1	0
Symbol	T4ReloadLo							
Access rights	r/w							

Table 119. T4ReloadLo bits

Bit	Symbol	Description
7 to 0	T4ReloadLo	Defines the low byte of the reload value of the timer 4. With the start event the timer loads the value of the T4ReloadVal. Changing this register affects the timer only at the next start event.

9.7.2.23 T4CounterValHi

High byte of the counter value of the 16-bit timer 4.

Table 120. T4CounterValHi register (address 26h)

Bit	7	6	5	4	3	2	1	0
Symbol	T4CounterValHi							
Access rights	dy							

Table 121. T4CounterValHi bits

Bit	Symbol	Description
7 to 0	T4CounterValHi	High byte of the current counter value of timer 4.

9.7.2.24 T4CounterValLo

Low byte of the counter value of the 16-bit timer 4.

Table 122. T4CounterValLo register (address 27h)

Bit	7	6	5	4	3	2	1	0
Symbol	T4CounterValLo							
Access rights	dy							

Table 123. T4CounterValLo bits

Bit	Symbol	Description
7 to 0	T4CounterValLo	Low byte of the current counter value of the timer 4.

9.8 Transmitter driver configuration registers

9.8.1 DrvMode

Table 124. DrvMode register (address 28h)

Bit	7	6	5	4	3	2	1	0
Symbol	Tx2Inv	Tx1Inv	-	-	TxEn	TxClk Mode		
Access rights	r/w	r/w	RFU	RFU	r/w	r/w		

Table 125. DrvMode bits

Bit	Symbol	Description
7	Tx2Inv	Inverts transmitter 2 at TX2 pin
6	Tx1Inv	Inverts transmitter 1 at TX1 pin
5		RFU
4	-	RFU
3	TxEn	If set to 1 both transmitter pins are enabled
2 to 0	TxCkMode	Transmitter clock settings (see 8.6.2. Table 27). Codes 011b and 0b110 are not supported. This register defines, if the output is operated in open drain, push-pull, at high impedance or pulled to a fix high or low level.

9.8.2 TxAmp

With the `set_cw_amplitude` register output power can be traded off against power supply rejection. Spending more headroom leads to better power supply rejection ration and better accuracy of the modulation degree.

With `CwMax` set, the voltage of TX1 will be pulled to the maximum possible. This register overrides the settings made by `set_cw_amplitude`.

Table 126. TxAmp register (address 29h)

Bit	7	6	5	4	3	2	1	0
Symbol	set_cw_amplitude		-	set_residual_carrier				
Access rights	r/w		RFU	r/w				

Table 127. TxAmp bits

Bit	Symbol	Description
7 to 6	set_cw_amplitude	Allows to reduce the output amplitude of the transmitter by a fix value. Four different preset values that are subtracted from TVDD can be selected: 0: TVDD -100 mV 1: TVDD -250 mV 2: TVDD -500 mV 3: T _{VDD} -1000 mV
5	RFU	-
4 to 0	set_residual_carrier	Set the residual carrier percentage. refer to Section 7.6.2

9.8.3 TxCon

Table 128. TxCon register (address 2Ah)

Bit	7	6	5	4	3	2	1	0
Symbol	OvershootT2				CwMax	TxInv	TxSel	
Access rights	r/w				r/w	r/w	r/w	

Table 129. TxCon bits

Bit	Symbol	Description
7 to 4	OvershootT2	Specifies the length (number of carrier clocks) of the additional modulation for overshoot prevention. Refer to Section 7.6.2.1 "Overshoot protection"
3	Cwmax	Set amplitude of continuous wave carrier to the maximum. If set, set_cw_amplitude in Register TxAmp has no influence on the continuous amplitude.
2	TxInv	If set, the resulting modulation signal defined by TxSel is inverted
1 to 0	TxSel	Defines which signal is used as source for modulation 00b ... no modulation 01b ... TxEnvelope 10b ... SigIn 11b ... RFU

9.8.4 TxI

Table 130. TxI register (address 2Bh)

Bit	7	6	5	4	3	2	1	0
Symbol	OvershootT1				tx_set_iLoad			
Access rights	r/w				r/w			

Table 131. TxI bits

Bit	Symbol	Description
7 to 4	OvershootT1	Overshoot value for Timer1. Refer to Section 7.6.2.1 "Overshoot protection"
3 to 0	tx_set_iLoad	Factory trim value, sets the expected Tx load current. This value is used to control the modulation index in an optimized way dependent on the expected TX load current.

9.9 Transmitter CRC configuration registers

9.9.1 TxCRcPreset

Table 132. TXCRcPreset register (address 2Ch)

Bit	7	6	5	4	3	2	1	0
Symbol	RFU	TXPresetVal			TxCRcType		TxCRCInvert	TxCRCEn
Access rights	-	r/w			r/w		r/w	r/w

Table 133. TxCRcPreset bits

Bit	Symbol	Description
7	RFU	-
6 to 4	TXPresetVal	Specifies the CRC preset value for transmission (see Table 133).
3 to 2	TxCRCType	Defines which type of CRC (CRC8/CRC16/CRC5) is calculated: <ul style="list-style-type: none"> • 00h -- CRC5 • 01h -- CRC8 • 02h -- CRC16 • 03h -- RFU
1	TxCRCInvert	if set, the resulting CRC is inverted and attached to the data frame (ISO/IEC 3309)
0	TxCRCEn	if set, a CRC is appended to the data stream

Table 134. Transmitter CRC preset value configuration

TXPresetVal[6...4]	CRC16	CRC8	CRC5
0h	0000h	00h	00h
1h	6363h	12h	12h
2h	A671h	BFh	-
3h	FFFEh	FDh	-
4h	-	-	-
5h	-	-	-
6h	User defined	User defined	User defined
7h	FFFFh	FFh	1Fh

Remark: User defined CRC preset values can be configured by EEprom (see [Section 7.7.2.1](#), [Table 30 "Configuration area \(Page 0\)"](#)).

9.9.2 Rx_crcCon

Table 135. Rx_crcCon register (address 2Dh)

Bit	7	6	5	4	3	2	1	0
Symbol	RxForceCRCWrite	RXPresetVal			RXCRCtype		RxCRCInvert	RxCRCEn
Access rights	r/w	r/w			r/w		r/w	r/w

Table 136. Rx_crcCon bits

Bit	Symbol	Description
7	RxForceCrc Write	If set, the received CRC byte(s) are copied to the FIFO. If cleared CRC Bytes are only checked, but not copied to the FIFO. This bit has to be always set in case of a not byte aligned CRC (e.g. ISO/IEC 18000-3 mode 3/ EPC Class-1HF)
6 to 4	RXPresetVal	Defines the CRC preset value (Hex.) for transmission. (see Table 136).
3 to 2	RxCRCtype	Defines which type of CRC (CRC8/CRC16/CRC5) is calculated: <ul style="list-style-type: none"> • 00h -- CRC5 • 01h -- CRC8 • 02h -- CRC16 • 03h -- RFU
1	RxCrcInvert	If set, the CRC check is done for the inverted CRC.
0	RxCrcEn	If set, the CRC is checked and in case of a wrong CRC an error flag is set. Otherwise the CRC is calculated but the error flag is not modified.

Table 137. Receiver CRC preset value configuration

RXPresetVal[6...4]	CRC16	CRC8	CRC5
0h	0000h	00h	00h
1h	6363h	12h	12h
2h	A671h	BFh	-
3h	FFFEh	FDh	-
4h	-	-	-
5h	-	-	-
6h	User defined	User defined	User defined
7h	FFFFh	FFh	1Fh

9.10 Transmitter data configuration registers

9.10.1 TxDataNum

Table 138. TxDataNum register (address 2Eh)

Bit	7	6	5	4	3	2	1	0
Symbol	RFU	RFU-	RFU-	KeepBitGrid	DataEn	TxLastBits		
Access rights				r/w	r/w	r/w		

Table 139. TxDataNum bits

Bit	Symbol	Description
7 to 5	RFU	-
4	KeepBitGrid	If set, the time between consecutive transmissions starts is a multiple of one ETU. If cleared, consecutive transmissions can even start within one ETU
3	DataEn	If cleared - it is possible to send a single symbol pattern. If set - data is sent.
2 to 0	TxLastBits	Defines how many bits of the last data byte to be sent. If set to 000b all bits of the last data byte are sent. Note - bits are skipped at the end of the byte. Example - Data byte B2h (sent LSB first). TxLastBits = 011b (3h) => 010b (LSB first) is sent TxLastBits = 110b (6h) => 010011b (LSB first) is sent

9.10.2 TxSym10BurstLen

If a protocol requires a burst (an unmodulated subcarrier) the length can be defined with this TxSymBurstLen, the value high or low can be defined by TxSym10BurstCtrl.

Table 140. TxSym10BurstLen register (address 30h)

Bit	7	6	5	4	3	2	1	0
Symbol	RFU	Sym1Burst Len			RFU	RFU		
Access rights	-	r/w			-	-		

Table 141. TxSym10BurstLen bits

Bit	Symbol	Description
7	RFU	-

Bit	Symbol	Description
6 to 4	Sym1BurstLen	Specifies the number of bits issued for symbol 1 burst. The 3 bits encodes a range from 8 to 256 bit: 00h - 8bit 01h - 16bit 02h - 32bit 04h - 48bit 05h - 64bit 06h - 96bit 07h - 128bit 08h - 256bit
3 to 0	RFU	-

9.10.3 TxWaitCtrl

Table 142. TxWaitCtrl register (address 31h); reset value: C0h

Bit	7	6	5	4	3	2	1	0
Symbol	TxWaitStart	TxWaitEtu	TxWait High			RFU		
Access rights	r/w	r/w	r/w			-		

Table 143. TXWaitCtrl bits

Bit	Symbol	Description
7	TxWaitStart	If cleared, the TxWait time is starting at the End of the send data (TX). If set, the TxWait time is starting at the End of the received data (RX).
6	TxWaitEtu	If cleared, the TxWait time is $TxWait \times 16/13.56$ MHz. If set, the TxWait time is $TxWait \times 0.5 / DBFreq$ (DBFreq is the frequency of the bit stream as defined by TxDataCon).
5 to 3	TxWait High	Bit extension of TxWaitLo. TxWaitCtrl bit 5 is MSB.
2 to 0	TxStopBitLength	Defines stop-bits and EGT (= stop-bit + extra guard time EGT) to be send: 0h: no stop-bit, no EGT 1h: 1 stop-bit, no EGT 2h: 1 stop-bit + 1 EGT 3h: 1 stop-bit + 2 EGT 4h: 1 stop-bit + 3 EGT 5h: 1 stop-bit + 4 EGT 6h: 1 stop-bit + 5 EGT 7h: 1 stop-bit + 6 EGT Note: This is only valid for ISO/IEC14443 Type B

9.10.4 TxWaitLo

Table 144. TxWaitLo register (address 32h)

Bit	7	6	5	4	3	2	1	0
Symbol	TxWaitLo							
Access rights	r/w							

Table 145. TxWaitLo bits

Bit	Symbol	Description
7 to 0	TxWaitLo	Defines the minimum time between receive and send or between two send data streams Note: TxWait is a 11bit register (additional 3 bits are in the TxWaitCtrl register)! See also TxWaitEtu and TxWaitStart.

9.11 FrameCon

Table 146. FrameCon register (address 33h)

Bit	7	6	5	4	3	2	1	0
Symbol	TxParityEn	RxParityEn	-	-	StopSym		StartSym	
Access rights	r/w	r/w	RFU	RFU	r/w		r/w	

Table 147. FrameCon bits

Bit	Symbol	Description
7	TxParityEn	If set, a parity bit is calculated and appended to each byte transmitted.
6	RxParityEn	If set, the parity calculation is enabled. The parity is not transferred to the FIFO.
5 to 4	-	RFU
3 to 2	StopSym	Defines which symbol is sent as stop-symbol: <ul style="list-style-type: none"> 0h: No symbol is sent 1h: Symbol0 is sent 2 h symbol1 is sent 3h Symbol2 is sent
1 to 0	StartSym	Defines which symbol is sent as start-symbol: <ul style="list-style-type: none"> 0h: No Symbol is sent 1h: Symbol0 is sent 2 h: Symbol1 is sent 3h: Symbol2 is sent

9.12 Receiver configuration registers

9.12.1 RxSofD

Table 148. RxSofD register (address 34h)

Bit	7	6	5	4	3	2	1	0
Symbol	RFU		SOF_En	SOFDetected	RFU	SubC_En	SubC_Detected	SubC_Present
Access rights	-		r/w	dy	-	r/w	dy	r

Table 149. RxSofD bits

Bit	Symbol	Description
7 to 6	RFU	-
5	SOF_En	If set and a SOF is detected an RxSOFIRQ is raised.
4	SOF_Detected	Shows that a SOF is or was detected. Can be cleared by SW.
3	RFU	-
2	SubC_En	If set and a subcarrier is detected an RxSOFIRQ is raised.
1	SubC_Detected	Shows that a subcarrier is or was detected. Can be cleared by SW.
0	SubC_Present	Shows that a subcarrier is currently detected.

9.12.2 RxCtrl

Table 150. RxCtrl register (address 35h)

Bit	7	6	5	4	3	2	1	0
Symbol	RxAllowBits	RxMultiple	RFU	RFU	EMD_Sup	Baudrate		
Access rights	r/w	r/w	-	-	r/w	r/w		

Table 151. RxCtrl bits

Bit	Symbol	Description
7	RxAllowBits	If set, data is written into FIFO even if CRC is enabled, and no complete byte has been received.
6	RxMultiple	If set, RxMultiple is activated and the receiver will not terminate automatically (refer Section 7.10.3.4 "Receive command"). If set to logic 1, at the end of a received data stream an error byte is added to the FIFO. The error byte is a copy of the Error register.
5 to 4	RFU	-
3	EMD_Sup	Enables the EMD suppression according ISO/IEC14443. If an error occurs within the first three bytes, these three bytes are assumed to be EMD, ignored and the FIFO is reset. A collision is treated as an error as well. If a valid SOF was received, the EMD_Sup is set and a frame of less than 3 bytes had been received. RX_IRQ is not set in this EMD error cases. If RxForceCRCWrite is set, the FIFO should not be read out before three bytes are written into.

Bit	Symbol	Description
2 to 0	Baudrate	Defines the baud rate of the receiving signal. 2h: 26 kBd 3h: 52 kBd all remaining values are RFU

9.12.3 RxWait

Selects internal receiver settings.

Table 152. RxWait register (address 36h)

Bit	7	6	5	4	3	2	1	0
Symbol	RxWaitEtu	RxWait						
Access rights	r/w	r/w						

Table 153. RxWait bits

Bit	Symbol	Description
7	RXWaitEtu	If set to 0, the RxWait time is RxWait × 16/13.56 MHz. If set to 1, the RxWait time is RxWait × (0.5/DBFreq).
6 to 0	RxWait	Defines the time after sending, where every input is ignored.

9.12.4 RxThreshold

Selects minimum threshold level for the bit decoder.

Table 154. RxThreshold register (address 37h)

Bit	7	6	5	4	3	2	1	0
Symbol	MinLevel				MinLevelP			
Access rights	r/w				r/w			

Table 155. RxThreshold bits

Bit	Symbol	Description
7 to 4	MinLevel	Defines the MinLevel of the reception. Note: The MinLevel should be higher than the noise level in the system.
3 to 0	MinLevelP	Defines the MinLevel of the phase shift detector unit.

9.12.5 Rcv

Table 156. Rcv register (address 38h)

Bit	7	6	5	4	3	2	1	0
Symbol	Rcv_Rx_single	Rx_ADCmode	SigInSel		RFU		CollLevel	

Bit	7	6	5	4	3	2	1	0
Access rights	r/w	r/w	r/w		-			r/w

Table 157. Rcv bits

Bit	Symbol	Description
7	Rcv_Rx_single	Single RXP Input Pin Mode; 0: Fully Differential 1: Quasi-Differential
6	Rx_ADCmode	Defines the operation mode of the Analog Digital Converter (ADC) 0: normal reception mode for ADC 1: LPCD mode for ADC
5 to 4	SigInSel	Defines input for the signal processing unit: 0h - idle 1h - internal analog block (RX) 2h - signal in over envelope (ISO/IEC14443A) 3h - signal in over s3c-generic
3 to 2	RFU	-
1 to 0	CollLevel	Defines the strength of a signal to be interpreted as a collision: 0h - Collision has at least 1/8 of signal strength 1h - Collision has at least 1/4 of signal strength 2h - Collision has at least 1/2 of signal strength 3h - Collision detection is switched off

9.12.6 RxAna

This register allows to set the gain (rcv_gain) and high pass corner frequencies (rcv_hpcf).

Table 158. RxAna register (address 39h)

Bit	7	6	5	4	3	2	1	0
Symbol	VMid_r_sel		RFU		rcv_hpcf		rcv_gain	
Access rights	r/w		-		r/w		r/w	

Table 159. RxAna bits

Bit	Symbol	Description
7, 6	VMid_r_sel	Factory trim value, needs to be 0.
5, 4	RFU	
3, 2	rcv_hpcf	The rcv_hpcf [1:0] signals allow 4 different settings of the base band amplifier high pass cut-off frequency from ~40 kHz to ~300 kHz.
1 to 0	rcv_gain	With rcv_gain[1:0] four different gain settings from 30 dB and 60 dB can be configured (differential output voltage/differential input voltage).

Table 160. Effect of gain and highpass corner register settings

rcv_gain (Hex.)	rcv_hpcf (Hex.)	f _l (kHz)	f _U (MHz)	gain (dB20)	bandwidth (MHz)
03	00	38	2,3	60	2,3
03	01	79	2,4	59	2,3
03	02	150	2,6	58	2,5
03	03	264	2,9	55	2,6
02	00	41	2,3	51	2,3
02	01	83	2,4	50	2,3
02	02	157	2,6	49	2,4
02	03	272	3,0	41	2,7
01	00	42	2,6	43	2,6
01	01	84	2,7	42	2,6
01	02	157	2,9	41	2,7
01	03	273	3,3	39	3,0
00	00	43	2,6	35	2,6
00	01	85	2,7	34	2,6
00	02	159	2,9	33	2,7
00	03	276	3,4	30	3,1

9.13 Clock configuration

9.13.1 SerialSpeed

This register allows to set speed of the RS232 interface. The default speed is set to 9,6kbit/s. The transmission speed of the interface can be changed by modifying the entries for BR_T0 and BR_T1. The transfer speed can be calculated by using the following formulas:

$$BR_T0 = 0: \text{transfer speed} = 27.12 \text{ MHz} / (BR_T1 + 1)$$

$$BR_T0 > 0: \text{transfer speed} = 27.12 \text{ MHz} / (BR_T1 + 33) / 2^{(BR_T0 - 1)}$$

The framing is implemented with 1 startbit, 8 databits and 1 stop bit. A parity bit is not used. Transfer speeds above 1228,8 kbit/s are not supported.

Table 161. SerialSpeed register (address3Bh); reset value: 7Ah

Bit	7	6	5	4	3	2	1	0
Symbol	BR_T0			BR_T1				
Access rights	r/w			r/w				

Table 162. SerialSpeed bits

Bit	Symbol	Description
7 to 5	BR_T0	BR_T0 = 0: transfer speed = 27.12 MHz / (BR_T1 + 1) BR_T0 > 0: transfer speed = 27.12 MHz / (BR_T1 + 33) / 2 ^(BR_T0 - 1)
4 to 0	BR_T1	BR_T0 = 0: transfer speed = 27.12 MHz / (BR_T1 + 1) BR_T0 > 0: transfer speed = 27.12 MHz / (BR_T1 + 33) / 2 ^(BR_T0 - 1)

Table 163. RS232 speed settings

Transfer speed (kbit/s)	SerialSpeed register content (Hex.)
7,2	FA
9,6	EB
14,4	DA
19,2	CB
38,4	AB
57,6	9A
115,2	7A
128,0	74
230,4	5A
460,8	3A
921,6	1C
1228,8	15

9.13.2 LFO_Trimm

Table 164. LFO_Trim register (address 3Ch)

Bit	7	6	5	4	3	2	1	0
Symbol	LFO_trimm							
Access rights	r/w							

Table 165. LFO_Trim bits

Bit	Symbol	Description
7 to 0	LFO_trimm	Trimm value. Refer to Section 8.8.3 Note: If the trimm value is increased, the frequency of the oscillator decreases.

9.13.3 PLL_Ctrl Register

The PLL_Ctrl register implements the control register for the IntegerN PLL. Two stages exist to create the ClkOut signal from the 27,12MHz input. In the first stage the 27,12Mhz input signal is multiplied by the value defined in PLLDiv_FB and divided by two, and the second stage divides this frequency by the value defined by PLLDIV_Out.

Table 166. PLL_Ctrl register (address 3Dh)

Bit	7	6	5	4	3	2	1	0
Symbol	ClkOutSel				ClkOut_En	PLL_PD	PLLDiv_FB	
Access rights	r/w				r/w	r/w	r/w	

Table 167. PLL_Ctrl register bits

Bit	Symbol	Description
7 to 4	ClkOutSel	<ul style="list-style-type: none"> 0h - pin CLKOUT is used as I/O 1h - pin CLKOUT shows the output of the analog PLL 2h - pin CLKOUT is hold on 0 3h - pin CLKOUT is hold on 1 4h - pin CLKOUT shows 27.12 MHz from the crystal 5h - pin CLKOUT shows 13.56 MHz derived from the crystal 6h - pin CLKOUT shows 6.78 MHz derived from the crystal 7h - pin CLKOUT shows 3.39 MHz derived from the crystal 8h - pin CLKOUT is toggled by the Timer0 overflow 9h - pin CLKOUT is toggled by the Timer1 overflow Ah - pin CLKOUT is toggled by the Timer2 overflow Bh - pin CLKOUT is toggled by the Timer3 overflow Ch...Fh - RFU
3	ClkOut_En	Enables the clock at Pin CLKOUT
2	PLL_PD	PLL power down
1-0	PLLDiv_FB	PLL feedback divider (see table 174)

Table 168. Setting of feedback divider PLLDiv_FB [1:0]

Bit 1	Bit 0	Division
0	0	23 (VCO frequency 312Mhz)
0	1	27 (VCO frequency 366MHz)
1	0	28 (VCO frequency 380Mhz)
1	1	23 (VCO frequency 312Mhz)

9.13.4 PLLDiv_Out

Table 169. PLLDiv_Out register (address 3Eh)

Bit	7	6	5	4	3	2	1	0
Symbol	PLLDiv_Out							
Access rights	r/w							

Table 170. PLLDiv_Out bits

Bit	Symbol	Description
7 to 0	PLLDiv_Out	PLL output divider factor; Refer to Section 7.8.2

Table 171. Setting for the output divider ratio PLLDiv_Out [7:0]

Value	Division
0	RFU
1	RFU
2	RFU
3	RFU
4	RFU
5	RFU
6	RFU
7	RFU
8	8
9	9
10	10
...	...
253	253
254	254

9.14 Low-power card detection configuration registers

The LPCD registers contain the settings for the low-power card detection. The setting for LPCD_IMax (6 bits) is done by the two highest bits (bit 7, bit 6) of the registers LPCD_QMin, LPCD_QMax and LPCD_IMin each.

9.14.1 LPCD_QMin

Table 172. LPCD_QMin register (address 3Fh)

Bit	7	6	5	4	3	2	1	0
Symbol	LPCD_IMax.5	LPCD_IMax.4	LPCD_QMin					
Access rights	r/w	r/w	r/w					

Table 173. LPCD_QMin bits

Bit	Symbol	Description
7, 6	LPCD_IMax	Defines the highest two bits of the higher border for the LPCD. If the measurement value of the I channel is higher than LPCD_IMax, a LPCD interrupt request is indicated by bit IRQ0.LPCDIRQ.

Bit	Symbol	Description
5 to 0	LPCD_QMin	Defines the lower border for the LPCD. If the measurement value of the Q channel is higher than LPCD_QMin, a LPCDinterrupt request is indicated by bit IRQ0.LPCDIRQ.

9.14.2 LPCD_QMax

Table 174. LPCD_QMax register (address 40h)

Bit	7	6	5	4	3	2	1	0
Symbol	LPCD_IMax.3	LPCD_IMax.2	LPCD_QMax					
Access rights	r/w	r/w	r/w					

Table 175. LPCD_QMax bits

Bit	Symbol	Description
7	LPCD_IMax.3	Defines the bit 3 of the high border for the LPCD. If the measurement value of the I channel is higher than LPCD IMax, a LPCD IRQ is raised.
6	LPCD_IMax.2	Defines the bit 2 of the high border for the LPCD. If the measurement value of the I channel is higher than LPCD IMax, a LPCD IRQ is raised.
5 to 0	LPCD_QMax	Defines the high border for the LPCD. If the measurement value of the Q channel is higher than LPCD QMax, a LPCD IRQ is raised.

9.14.3 LPCD_IMin

Table 176. LPCD_IMin register (address 41h)

Bit	7	6	5	4	3	2	1	0
Symbol	LPCD_IMax.1	LPCD_IMax.0	LPCD_IMin					
Access rights	r/w	r/w	r/w					

Table 177. LPCD_IMin bits

Bit	Symbol	Description
7 to 6	LPCD_IMax	Defines lowest two bits of the higher border for the low-power card detection (LPCD). If the measurement value of the I channel is higher than LPCD IMax, a LPCD IRQ is raised.
5 to 0	LPCD_IMin	Defines the lower border for the low power card detection. If the measurement value of the I channel is lower than LPCD IMin, a LPCD IRQ is raised.

9.14.4 LPCD_Result_I

Table 178. LPCD_Result_I register (address 42h)

Bit	7	6	5	4	3	2	1	0
Symbol	RFU-	RFU-	LPCD_Result_I					
Access rights	-	-	r					

Table 179. LPCD_I_Result bits

Bit	Symbol	Description
7 to 6	RFU	-
5 to 0	LPCD_Result_I	Shows the result of the last low-power card detection (I-Channel).

9.14.5 LPCD_Result_Q

Table 180. LPCD_Result_Q register (address 43h)

Bit	7	6	5	4	3	2	1	0
Symbol	RFU	LPCD_IRQ_Clr	LPCD_Result_Q					
Access rights		r/w	r					

Table 181. LPCD_Q_Result bits

Bit	Symbol	Description
7	RFU	-
6	LPCD_IRQ_Clr	If set no LPCD IRQ is raised any more until the next low-power card detection procedure. Can be used by software to clear the interrupt source.
5 to 0	LPCD_Result_Q	Shows the result of the last low power card detection (Q-Channel).

9.14.6 LPCD_Options

This register is available on the SLRC61003 only. For silicon version SLRC61002 this register on address 3Ah is RFU.

Table 182. LPCD_Options register (address 3Ah)

Bit	7	6	5	4	3	2	1	0
Symbol	RFU			LPCD_TX_HIGH	LPCD_FILTER	LPCD_Q_UNSTABLE	LPCD_I_UNSTABLE	
Access rights	-			r/w	r/w	r	r	

Table 183. LPCD_Options

Bit	Symbol	Description
7 to 4	RFU	-
3	LPCD_TX_HIGH	If set, the TX-driver will be the same as V_{TVDD} during LPCD. This will allow for a better LPCD detection range (higher transmitter output voltage) at the cost of a higher current consumption. If this bit is cleared, the output voltage at the TX drivers will be $= V_{TVDD} - 0.4V$. If this bit is set, the output voltage at the TX drivers will be $= V_{TVDD}$.
2	LPCD_FILTER	If set, The LPCD decision is based on the result of a filter which allows to remove noise from the evaluated signal in I and Q channel. Enabling LPCD_FILTER allows compensating for noisy conditions at the cost of a longer RF-ON time required for sampling. The total maximum LPCD sampling time is 4.72us.
1	LPCD_Q_UNSTABLE	If bit 2 of this register is set, bit 1 indicates that the Q-channel ADC value was changing during the LPCD measuring time. Note: Only valid if LPCD_FILTER (bit 2) = 1. This information can be used by the host application for configuration of e.g. the threshold LPCD_QMax or inverting the TX drivers.
0	LPCD_I_UNSTABLE	If bit 2 of this register is set, bit 0 Indicates that the I-channel ADC value was changing during the LPCD measuring time. Note: Only valid if LPCD_FILTER (bit2) = 1. This information can be used by the host application for configuration of e.g. the threshold LPCD_IMax or inverting the TX drivers.

9.15 Pin configuration

9.15.1 PadEn

Table 184. PadEn register (address 44h)

Bit	7	6	5	4	3	2	1	0
Symbol	SIGIN_EN / OUT7	CLKOUT_EN / OUT6	IFSEL1_EN / OUT5	IFSEL0_EN / OUT4	TCK_EN / OUT 3	TMS_EN / OUT2	TDI_EN / OUT1	TDO_EN / OUT0
Access rights	r/w	r/w	r/w	r/w	r/w	r/w	r/w	r/w

Table 185. PadEn bits

Bit	Symbol	Description
7	SIGIN_EN / OUT7	Enables the output functionality on SIGIN (pin 5). The pin is then used as output.
6	CLKOUT_EN / OUT6	Enables the output functionality of the CLKOUT (pin 22). The pin is then used as output. The CLKOUT function is switched off.
5	IFSEL1_EN / OUT5	Enables the output functionality of the IFSEL1 (pin 27). The pin is then used as output.
4	IFSEL0_EN / OUT4	Enables the output functionality of the IFSEL0 (pin 26). The pin is then used as output.
3	TCK_EN / OUT3	Enables the output functionality of the TCK (pin 4) of the boundary scan interface. The pin is then used as output. If the boundary scan is activated in EEPROM, this bit has no function.

Bit	Symbol	Description
2	TMS_EN / OUT2	Enables the output functionality of the TMS (pin 2) of the boundary scan interface. The pin is then used as output. If the boundary scan is activated in EEPROM, this bit has no function.
1	TDI_EN / OUT1	Enables the output functionality of the TDI (pin 1) of the boundary scan interface. The pin is then used as output. If the boundary scan is activated in EEPROM, this bit has no function.
0	TDO_EN / OUT0	Enables the output functionality of the TDO (pin 3) of the boundary scan interface. The pin is then used as output. If the boundary scan is activated in EEPROM, this bit has no function.

9.15.2 PadOut

Table 186. PadOut register (address 45h)

Bit	7	6	5	4	3	2	1	0
Symbol	SIGIN_OUT	CLKOUT_OUT	IFSEL1_OUT	IFSEL0_OUT	TCK_OUT	TMS_OUT	TDI_OUT	TDO_OUT
Access rights	r/w	r/w	r/w	r/w	r/w	r/w	r/w	r/w

Table 187. PadOut bits

Bit	Symbol	Description
7	SIGIN_OUT	Output buffer of the SIGIN pin
6	CLKOUT_OUT	Output buffer of the CLKOUT pin
5	IFSEL1_OUT	Output buffer of the IFSEL1 pin
4	IFSEL0_OUT	Output buffer of the IFSEL0 pin
3	TCK_OUT	Output buffer of the TCK pin
2	TMS_OUT	Output buffer of the TMS pin
1	TDI_OUT	Output buffer of the TDI pin
0	TDO_OUT	Output buffer of the TDO pin

9.15.3 PadIn

Table 188. PadIn register (address 46h)

Bit	7	6	5	4	3	2	1	0
Symbol	SIGIN_IN	CLKOUT_IN	IFSEL1_IN	IFSEL0_IN	TCK_IN	TMS_IN	TDI_IN	TDO_IN
Access rights	r	r	r	r	r	r	r	r

Table 189. PadIn bits

Bit	Symbol	Description
7	SIGIN_IN	Input buffer of the SIGIN pin
6	CLKOUT_IN	Input buffer of the CLKOUT pin
5	IFSEL1_IN	Input buffer of the IFSEL1 pin
4	IFSEL0_IN	Input buffer of the IFSEL0 pin
3	TCK_IN	Input buffer of the TCK pin
2	TMS_IN	Input buffer of the TMS pin
1	TDI_IN	Input buffer of the TDI pin
0	TDO_IN	Input buffer of the TDO pin

9.15.4 SigOut

Table 190. SigOut register (address 47h)

Bit	7	6	5	4	3	2	1	0
Symbol	Pad Speed	RFU			SigOutSel			
Access rights	r/w	-			r/w			

Table 191. SigOut bits

Bit	Symbol	Description
7	PadSpeed	If set, the I/O pins are supporting a fast switching mode. The fast mode for the I/O's will increase the peak current consumption of the device, especially if multiple I/Os are switching at the same time. The power supply needs to be designed to deliver this peak currents.
6 to 4	RFU	-
3 to 0	SIGOutSel	0h, 1h - The pin SIGOUT is 3-state 2h - The pin SIGOUT is 0 3h - The pin SIGOUT is 1 4h - The pin SIGOUT shows the TX-envelope 5h - The pin SIGOUT shows the TX-active signal 6h - The pin SIGOUT shows the S3C (generic) signal 7h - The pin SIGOUT shows the RX-envelope (only valid for ISO/IEC 14443A, 106 kBd) 8h - The pin SIGOUT shows the RX-active signal 9h - The pin SIGOUT shows the RX-bit signal

9.16 Version register

9.16.1 Version

Table 192. Version register (address 7Fh)

Bit	7	6	5	4	3	2	1	0
Symbol	Version				SubVersion			
Access rights	r				r			

Table 193. Version bits

Bit	Symbol	Description
7 to 4	Version	Includes the version of the SLRC610 silicon. SLRC61002: 0x1 SLRC61003: 0x1
3 to 0	SubVersion	Includes the subversion of the SLRC610 silicon: CLRC66302: 0x8 CLRC66303: 0xA LPCD_OPTIONS register had been added compared to the earlier version SLRC61002. Default configuration for LoadProtocol updated for improved performance. User EEPROM initialized with data. Transmitter driver allows higher ITVDD than lower SubVersions.

10 Limiting values

Table 194. Limiting values

In accordance with the Absolute Maximum Rating System (IEC 60134).

Symbol	Parameter	Conditions	Min	Max	Unit
V_{DD}	supply voltage		-0.5	+ 6.0	V
$V_{DD(PVDD)}$	PVDD supply voltage		-0.5	+ 6.0	V
$V_{DD(TVDD)}$	TVDD supply voltage		-0.5	+ 6.0	V
$I_{DD(TVDD)}$	TVDD supply current	SLRC61002	-	250	mA
		SLRC61003	-		500
$V_{i(RXP)}$	input voltage on pin RXP		-0.5	+ 2.0	V
$V_{i(RXN)}$	input voltage on pin RXN		-0.5	+ 2.0	V
P_{tot}	total power dissipation	per package	-	1125	mW
$V_{ESD(HBM)}$	electrostatic discharge voltage	Human Body Model (HBM); 1500 Ω , 100 pF; JESD22-A114-B	-2000	2000	V
$V_{ESD(CDM)}$	electrostatic discharge voltage	Charge Device Model (CDM);	-500	500	V
$T_{j(max)}$	maximum junction temperature		-	125	$^{\circ}\text{C}$
T_{stg}	storage temperature	no supply voltage applied	-55	+150	$^{\circ}\text{C}$

11 Recommended operating conditions

Exposure of the device to other conditions than specified in the Recommended Operating Conditions section for extended periods may affect device reliability.

Electrical parameters (minimum, typical and maximum) of the device are guaranteed only when it is used within the recommended operating conditions.

Table 195. Operating conditions SLRC61002HN

Symbol	Parameter	Conditions	Min	Typ	Max	Unit
V _{DD}	supply voltage		3.0	5.0	5.5	V
V _{DD(TVDD)}	TVDD supply voltage		^[1] 3.0	5.0	5.5	V
V _{DD(PVDD)}	PVDD supply voltage		3.0	5.0	5.5	V
T _{amb}	operating ambient temperature	in still air with exposed pin soldered on a 4 layer JEDEC PCB	-25	+25	+85	°C
T _{stg}	storage temperature	no supply voltage applied, relative humidity 45...75%	-40	+25	+125	°C

[1] V_{DD(PVDD)} must always be the same or lower than V_{DD}.

Table 196. Operating conditions SLRC61003HN

Symbol	Parameter	Conditions	Min	Typ	Max	Unit
V _{DD}	supply voltage		2.5	5.0	5.5	V
V _{DD(TVDD)}	TVDD supply voltage		^[1] 2.5	5.0	5.5	V
V _{DD(PVDD)}	PVDD supply voltage	all host interfaces except I2C interface	2.5	5.0	5.5	V
		all host interfaces incl. I2C interface	3.0	5.0	5.5	V
T _{amb}	operating ambient temperature	in still air with exposed pin soldered on a 4 layer JEDEC PCB	-40	+25	+105	°C
T _{stg}	storage temperature	no supply voltage applied, relative humidity 45...75%	-45	+25	+125	°C

[1] V_{DD(PVDD)} must always be the same or lower than V_{DD}.

12 Thermal characteristics

Table 197. Thermal characteristics

Symbol	Parameter	Conditions	Package	Typ	Unit
$R_{th(j-a)}$	thermal resistance from junction to ambient	in still air with exposed pin soldered on a 4 layer JEDEC PCB	HVQFN32	40	K/W

13 Characteristics

Table 198. Characteristics

Symbol	Parameter	Conditions	Min	Typ	Max	Unit
Current consumption						
I _{DD}	supply current	I _{DD} = A _{VDD} +D _{VDD} ; modem on (transmitter and receiver are switched on)	-	17	20	mA
		I _{DD} = A _{VDD} +D _{VDD} ; modem off (transmitter and receiver are switched off)	-	0.45	0.5	mA
I _{DD(PVDD)}	PVDD supply current	no load on digital pins, leakage current only	-	0.5	5	μA
I _{DD(TVDD)}	TVDD supply current	SLRC61002HN	-	100	250	mA
		SLRC61003HN	-	250	350	mA
I _{pd}	power-down current	All OUTx pins floating				
		ambient temp = +25 °C	-	40	400	nA
		ambient temp = -40°C... +85°C	-	1.5	2.1	μA
		SLRC61003: ambient temp = +105 °C	-	3.5	5.2	μA
I _{stby}	standby current	All OUTx pins floating				
		ambient temp = 25 °C, I _{VDD} +I _{TVDD} + I _{PVDD}	-	3	6	μA
I _{LPCD(sleep)}	LPCD sleep current	ambient temp = -40°C... +105°C, I _{stby} = I _{VDD} +I _{TVDD} + I _{PVDD}	-	5.25	26	μA
		All OUTx pins floating				
I _{LPCD(sleep)}	LPCD sleep current	LFO active, no RF field on, ambient temp = 25 °C	[1] -	3.3	6.3	μA
I _{LPCD(average)}	LPCD average current	All OUTx pins floating, TxLoad = 50 ohms. LPCD_FILTER = 0; Rfon duration = 10 us, RF-off duration 300ms; V _{TVDD} = 3.0V; T _{amb} = 25°C; I _{LPCD} = I _{VDD} +I _{TVDD} + I _{PVDD}				
		LPCD_TX_HIGH = 0,	-	12	-	μA
		LPCD_TX_HIGH = 1	-	23	-	μA
t _{RFON}	RF-on time during LPCD	LPCD_TX_HIGH = 0; TVDD=5.0 V T=25C;	-	10	-	μs
		LPCD_TX_HIGH = 1; TVDD=5.0 V; T=25C	-	50	-	μs
Buffer capacitors on AVDD,DVDD						
C _L	external buffer capacitor	AVDD	220	470	-	nF

Symbol	Parameter	Conditions	Min	Typ	Max	Unit
C _L	external buffer capacitor	DVDD	220	470	-	nF
I/O pin characteristics SIGIN/OUT7, SIGOUT, CLKOUT/OUT6, IFSEL0/OUT4, IFSEL1/OUT5, TCK/OUT3, TMS/OUT2, TDI/OUT1, TDO/OUT0, IRQ, IF0, IF1, IF2, SCL2, SDA2						
I _{LI}	input leakage current	output disabled	0.0	50	500	nA
V _{IL}	low-level input voltage		-0.5	-	0.3 x V _{DD(PVDD)}	V
V _{IH}	high-level input voltage		0.7 x V _{DD(PVDD)}	V _{DD(PVDD)}	V _{DD(PVDD)} + 0.5	V
V _{OL}	low-level output voltage		0.0	0.0	0.4	V
V _{OH}	high-level output voltage	If pins are used as output OUTx, I _{OH} = 4 mA driving current for each pin	V _{DD(PVDD)} -0.4	V _{DD(PVDD)}	V _{DD(PVDD)}	V
C _i	input capacitance		0.0	2.5	4.5	pF
Pin characteristics PDOWN						
V _{IL}	low-level input voltage		0.0	0.0	0.4	V
V _{IH}	high-level input voltage		0.6 x V _{PVDD}	V _{DD(PVDD)}	V _{DD(PVDD)}	V
Pull-up resistance for TCK, TMS, TDI, IF2						
R _{pu}	pull-up resistance		50	72	120	KΩ
Pin characteristics AUX 1, AUX 2						
V _o	output voltage		0.0	-	1.8	V
C _L	load capacitance		0.0	-	400	pF
Pin characteristics RXP, RXN						
V _{pp}	input voltage		0	1.65	1.8	V
C _i	input capacitance		2	3.5	5	pF
V _{mod(pp)}	modulation voltage	V _{mod(pp)} = V _{i(pp)(max)} - V _{i(pp)(min)}	-	2.5	-	mV
Pins TX1 and TX2						
V _o	output voltage		V _{ss(TVSS)}	-	V _{DD(TVDD)}	V
R _o	output resistance	SLRC61002 T=25°C, V _{DD(TVDD)} = 5.0V	-	1.5	-	Ω
		SLRC61003: T=25°C, V _{DD(TVDD)} = 5.0V	-	1.2	-	Ω
Clock frequency Pin CLKOUT						
f _{clk}	clock frequency	configured to 27.12 MHz	-	27.12	-	MHz
δ _{clk}	clock duty cycle		-	50	-	%
Crystal connection XTAL1, XTAL2						
V _{o(p-p)}	peak-to-peak output voltage	pin XTAL1	-	1.0	-	V
V _i	input voltage	pin XTAL1	0.0	-	1.8	V
C _i	input capacitance	pin XTAL1	-	3	-	pF

Symbol	Parameter	Conditions	Min	Typ	Max	Unit
Crystal requirements						
f_{xtal}	crystal frequency	ISO/IEC14443 compliancy	27.12-14kHz	27.12	27.12+14kHz	MHz
ESR	equivalent series resistance		-	50	100	Ω
C_L	load capacitance		-	10	-	pF
P_{xtal}	crystal power dissipation		-	50	100	μW
Input characteristics I/O Pin Characteristics IF3-SDA in I²C configuration						
I_{LI}	input leakage current	output disabled	-	2	100	nA
V_{IL}	LOW-level input voltage		-0.5	-	+0.3 $V_{\text{DD(PVDD)}}$	V
V_{IH}	HIGH-level input voltage		0.7 $V_{\text{DD(PVDD)}}$	-	$V_{\text{DD(PVDD)}} + 0.5$	V
V_{OL}	LOW-level output voltage	$I_{\text{OL}} = 3 \text{ mA}$	-	-	0.3	V
I_{OL}	LOW-level output current	$V_{\text{OL}} = 0.4 \text{ V}$; Standard mode, Fast mode	4	-	-	mA
		$V_{\text{OL}} = 0.6 \text{ V}$; Standard mode, Fast mode	6	-	-	mA
$t_{\text{f(o)}}$	output fall time	Standard mode, Fast mode, $C_L < 400 \text{ pF}$	-	-	250	ns
		Fast mode +; $C_L < 550 \text{ pF}$	-	-	120	ns
t_{SP}	pulse width of spikes that must be suppressed by the input filter		0	-	50	ns
C_i	input capacitance		-	3.5	5	pF
C_L	load capacitance	Standard mode	-	-	400	pF
		Fast mode	-	-	550	pF
t_{EER}	EEPROM data retention time	$T_{\text{amb}} = +55 \text{ }^\circ\text{C}$	10	-	-	year
N_{EEC}	EEPROM endurance (number of programming cycles)	under all operating conditions	5×10^5	-	-	cycle

[1] I_{pd} is the total current for all supplies.



Figure 27. Pin RX input voltage

13.1 Timing characteristics

Table 199. SPI timing characteristics

Symbol	Parameter	Conditions	Min	Typ	Max	Unit
t _{SCKL}	SCK LOW time		50	-	-	ns
t _{SCKH}	SCK HIGH time		50	-	-	ns
t _{h(SCKH-D)}	SCK HIGH to data input hold time	SCK to changing MOSI	25	-	-	ns
t _{su(D-SCKH)}	data input to SCK HIGH set-up time	changing MOSI to SCK	25	-	-	ns
t _{h(SCKL-Q)}	SCK LOW to data output hold time	SCK to changing MISO	-	-	25	ns
t _(SCKL-NSSH)	SCK LOW to NSS HIGH time		0	-	-	ns
t _{NSSH}	NSS HIGH time	before communication	50	-	-	ns

Remark: To send more bytes in one data stream the NSS signal must be LOW during the send process. To send more than one data stream the NSS signal must be HIGH between each data stream.

Table 200. I²C-bus timing in fast mode and fast mode plus

Symbol	Parameter	Conditions	Fast mode		Fast mode Plus		Unit
			Min	Max	Min	Max	
f _{SCL}	SCL clock frequency		0	400	0	1000	kHz
t _{HD;STA}	hold time (repeated) START condition	after this period, the first clock pulse is generated	600	-	260	-	ns
t _{SU;STA}	set-up time for a repeated START condition		600	-	260	-	ns
t _{SU;STO}	set-up time for STOP condition		600	-	260	-	ns
t _{LOW}	LOW period of the SCL clock		1300	-	500	-	ns
t _{HIGH}	HIGH period of the SCL clock		600	-	260	-	ns
t _{HD;DAT}	data hold time		0	900	-	450	ns

Symbol	Parameter	Conditions	Fast mode		Fast mode Plus		Unit
			Min	Max	Min	Max	
$t_{SU;DAT}$	data set-up time		100	-	-	-	ns
t_r	rise time	SCL signal	20	300	-	120	ns
t_f	fall time	SCL signal	20	300	-	120	ns
t_r	rise time	SDA and SCL signals	20	300	-	120	ns
t_f	fall time	SDA and SCL signals	20	300	-	120	ns
t_{BUF}	bus free time between a STOP and START condition		1.3	-	0.5	-	μ s



Figure 28. Timing for fast and standard mode devices on the I²C-bus

14 Application information

A typical application diagram using a complementary antenna connection to the SLRC610 is shown in [Figure 29](#).

The antenna tuning and RF part matching is described in the application note [\[1\]](#) and [\[2\]](#).

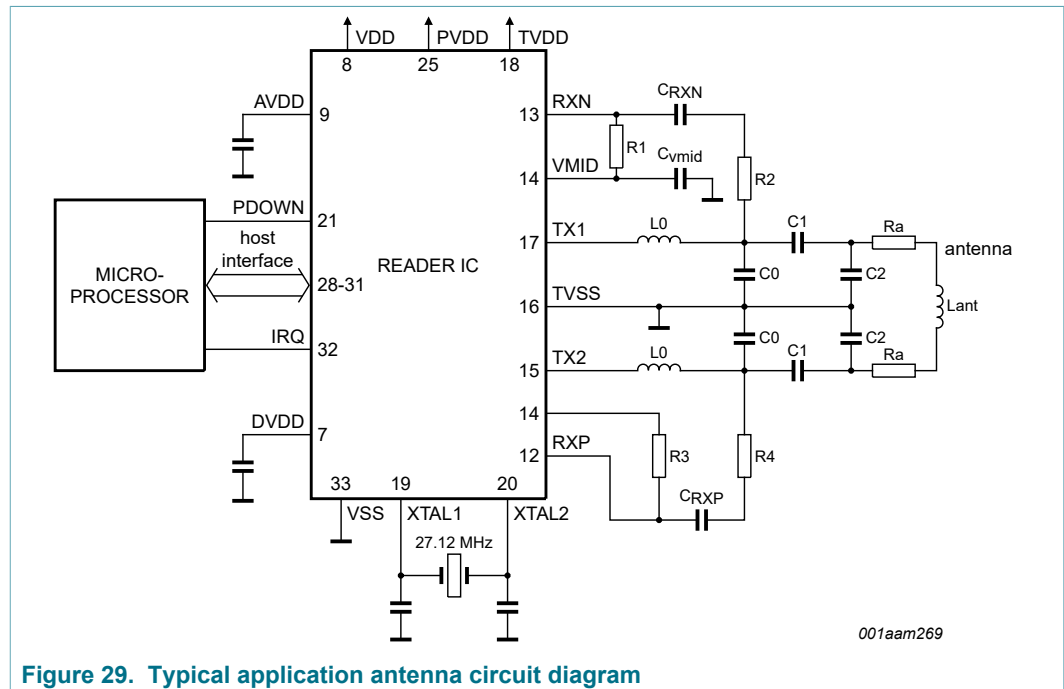

Figure 29. Typical application antenna circuit diagram

14.1 Antenna design description

The matching circuit for the antenna consists of an EMC low pass filter (L0 and C0), a matching circuitry (C1 and C2), and a receiving circuits (R1 = R3, R2 = R4, C3 = C5 and C4 = C6;), and the antenna itself. The receiving circuit component values needs to be designed for operation with the SLRC610. A reuse of dedicated antenna designs done for other products without adaptation of component values will result in degraded performance.

14.1.1 EMC low pass filter

The MIFARE product-based system operates at a frequency of 13.56 MHz. This frequency is derived from a quartz oscillator to clock the SLRC610 and is also the basis for driving the antenna with the 13.56 MHz energy carrier. This will not only cause emitted power at 13.56 MHz but will also emit power at higher harmonics. The international EMC regulations define the amplitude of the emitted power in a broad frequency range. Thus, an appropriate filtering of the output signal is necessary to fulfil these regulations.

Remark: The PCB layout has a major influence on the overall performance of the filter.

14.1.2 Antenna matching

Due to the impedance transformation of the given low pass filter, the antenna coil has to be matched to a certain impedance. The matching elements C1 and C2 can be estimated and have to be fine tuned depending on the design of the antenna coil.

The correct impedance matching is important to provide the optimum performance. The overall quality factor has to be considered to guarantee a proper ISO/IEC 14443 communication scheme. Environmental influences have to be considered as well as common EMC design rules.

For details refer to the NXP application notes.

14.1.3 Receiving circuit

The internal receiving concept of the SLRC610 makes use both side-bands of the sub-carrier load modulation of the card response via a differential receiving concept (RXP, RXN). No external filtering is required.

It is recommended to use the internally generated VMID potential as the input potential of pin RX. This DC voltage level of VMID has to be coupled to the Rx-pins via R2 and R4. To provide a stable DC reference voltage capacitances C4, C6 has to be connected between VMID and ground. Refer to [Figure 29](#)

Considering the (AC) voltage limits at the Rx-pins the AC voltage divider of R1 + C3 and R2 as well as R3 + C5 and R4 has to be designed. Depending on the antenna coil design and the impedance matching the voltage at the antenna coil varies from antenna design to antenna design. Therefore the recommended way to design the receiving circuit is to use the given values for R1(= R3), R2 (= R4), and C3 (= C5) from the above mentioned application note, and adjust the voltage at the RX-pins by varying R1(= R3) within the given limits.

Remark: R2 and R4 are AC-wise connected to ground (via C4 and C6).

14.1.4 Antenna coil

The precise calculation of the antenna coils' inductance is not practicable but the inductance can be **estimated** using the following formula. We recommend designing an antenna either with a circular or rectangular shape.

$$L_1 = 2 \cdot I_1 \cdot \left(\ln \left\langle \frac{I_1}{D_1} \right\rangle - K \right) N_1^{1,8} \quad (2)$$

- I_1 - Length in cm of one turn of the conductor loop
- D_1 - Diameter of the wire or width of the PCB conductor respectively
- K - Antenna shape factor (K = 1,07 for circular antennas and K = 1,47 for square antennas)
- L_1 - Inductance in nH
- N_1 - Number of turns
- Ln: Natural logarithm function

The actual values of the **antenna inductance, resistance, and capacitance at 13.56 MHz** depend on various parameters such as:

- antenna construction (Type of PCB)
- thickness of conductor
- distance between the windings
- shielding layer
- metal or ferrite in the near environment

Therefore a measurement of those parameters under real life conditions, or at least a rough measurement and a tuning procedure is highly recommended to guarantee a reasonable performance. For details refer to the above mentioned application notes.

15 Package outline

HVQFN32: plastic thermal enhanced very thin quad flat package; no leads;
32 terminals; body 5 x 5 x 0.85 mm

SOT617-1

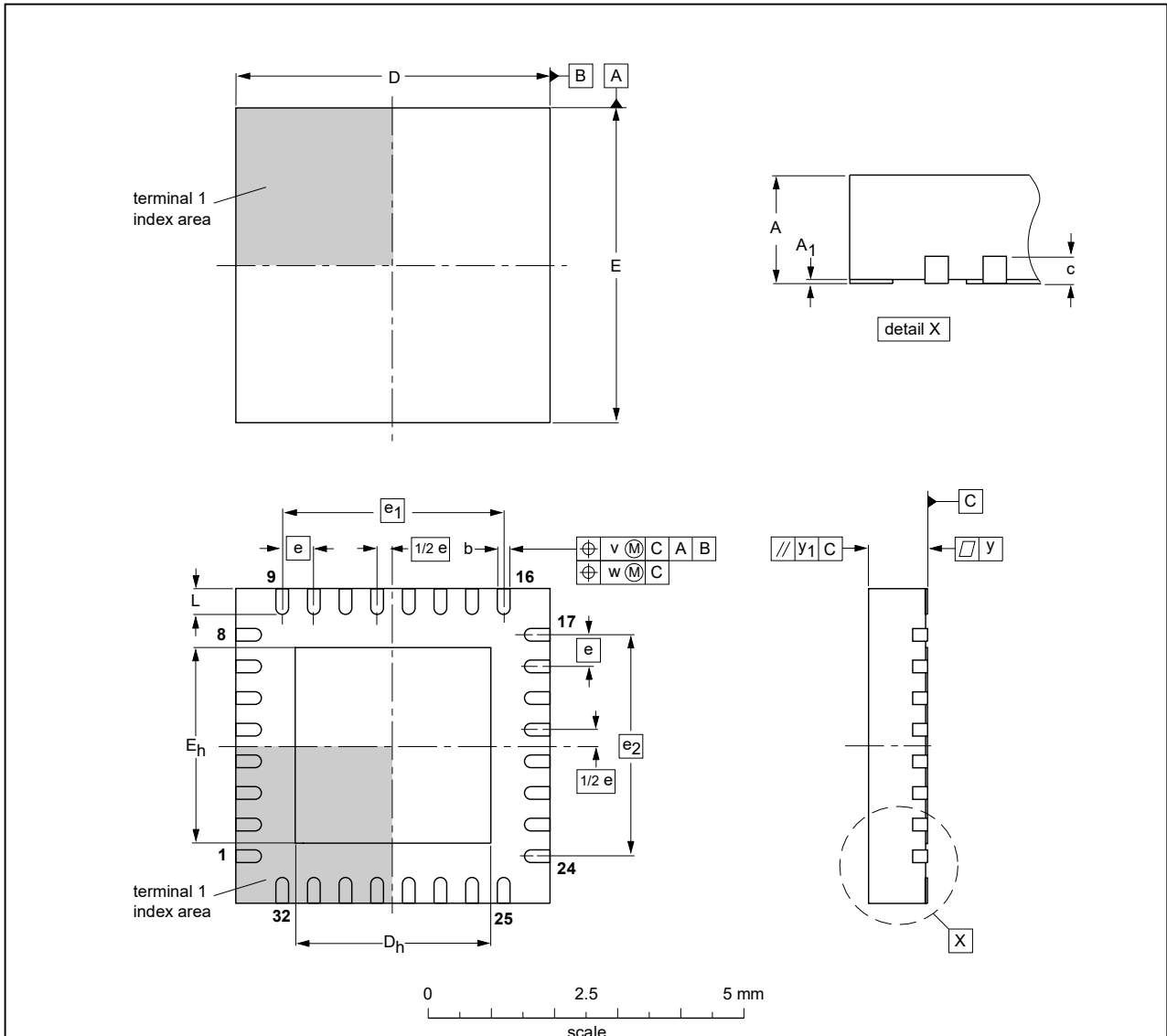

DIMENSIONS (mm are the original dimensions)

UNIT	A ⁽¹⁾ max.	A ₁	b	c	D ⁽¹⁾	D _h	E ⁽¹⁾	E _h	e	e ₁	e ₂	L	v	w	y	y ₁
mm	1	0.05 0.00	0.30 0.18	0.2	5.1 4.9	3.25 2.95	5.1 4.9	3.25 2.95	0.5	3.5	3.5	0.5 0.3	0.1	0.05	0.05	0.1

Note

1. Plastic or metal protrusions of 0.075 mm maximum per side are not included.

OUTLINE VERSION	REFERENCES			EUROPEAN PROJECTION	ISSUE DATE
	IEC	JEDEC	JEITA		
SOT617-1	---	MO-220	---		-01-08-08- 02-10-18

Figure 30. Package outline SOT617-1 (HVQFN32)

Detailed package information can be found at <http://www.nxp.com/package/SOT617-1.html>.

16 Handling information

Moisture Sensitivity Level (MSL) evaluation has been performed according to *SNW-FQ-225B rev.04/07/07 (JEDEC J-STD-020C)*. MSL for this package is level 2 which means 260 °C convection reflow temperature.

For MSL2:

- Dry pack is required.
- 1 year out-of-pack floor life at maximum ambient temperature 30 °C/ 85 % RH.

For MSL1:

- No dry pack is required.
- No out-of-pack floor live spec. required.

17 Packing information

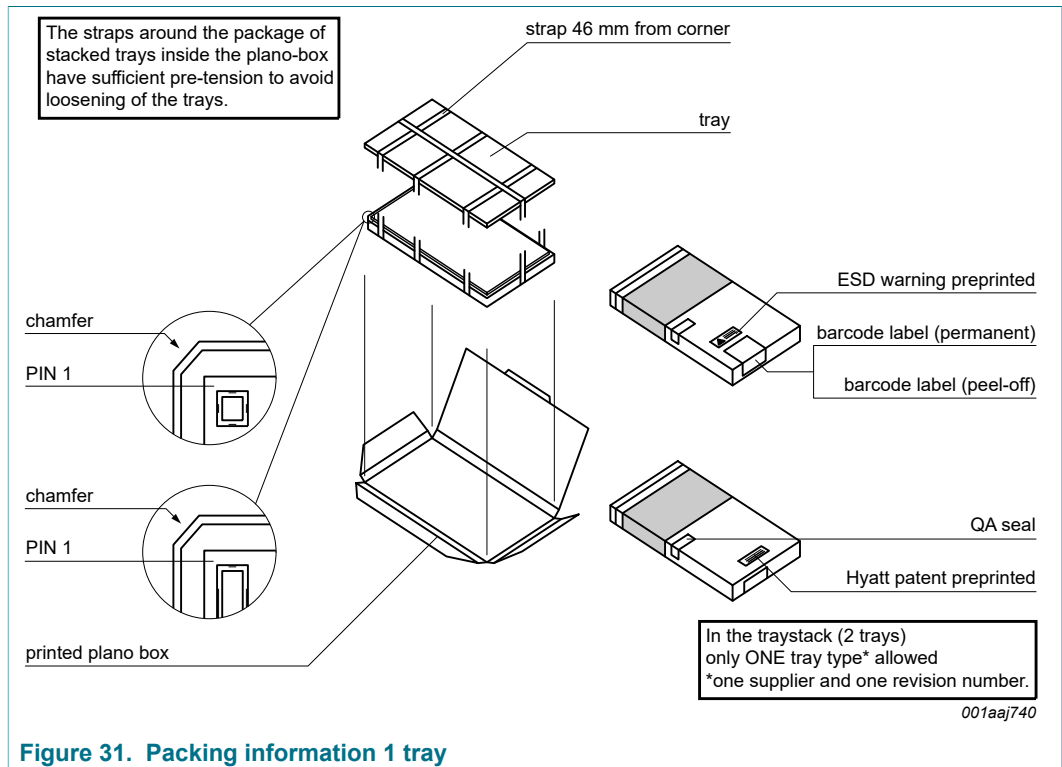

Figure 31. Packing information 1 tray

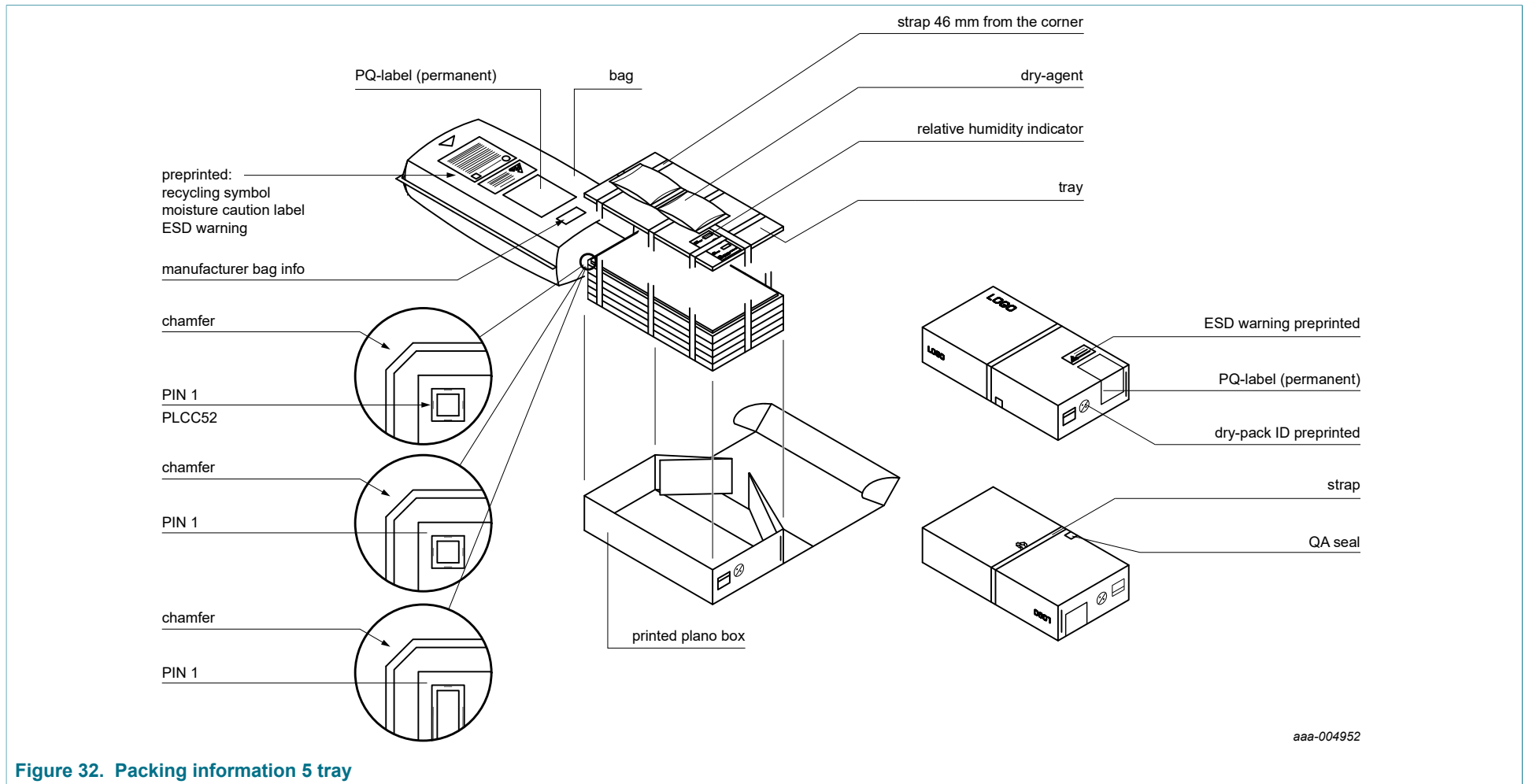

Figure 32. Packing information 5 tray



Figure 33. Tray details



Figure 34. Packing information Reel

18 Appendix

18.1 LoadProtocol command register initialization

The RF configuration is loaded with the command Load Protocol. The tables below show the register configuration as performed by this command for each of the protocols. Antenna specific configurations are not covered by this register settings.

The SLRC61002 is not initialized for any antenna configuration. For this products the antenna configuration needs to be done by firmware.

The SLRC61003 antenna configuration in the user EEPROM is described in the chapter [Section 18.2](#).

Table 201. Protocol Number 00: ISO/IEC15693 SLI 1/4 - SSC- 26

Value for register	Value (hex)
TxBitMod	00
RFU	00
TxDataCon	83
TxDataMod	04
TxSymFreq	40
TxSym0H	00
TxSym0L	00
TxSym1H	00
TxSym1L	00
TxSym2	84
TxSym3	02
TxSym10Len	00
TxSym32Len	37
TxSym10BurstCtrl	00
TxSym10Mod	00
TxSym32Mod	00
RxBitMod	00
RxEofSym	1D
RxSyncValH	00
RxSyncValL	01
RxSyncMod	00
RxMod	24
RxCorr	60
FabCal	F0

Table 202. Protocol Number 01: ISO/IEC15693 SLI 1/4 - SSC- 53

Value for register	Value (hex)
TxBitMod	00
RFU	00
TxDataCon	83
TxDataMod	04
TxSymFreq	40
TxSym0H	00
TxSym0L	00
TxSym1H	00
TxSym1L	00
TxSym2	84
TxSym3	02
TxSym10Len	00
TxSym32Len	37
TxSym10BurstCtrl	00
TxSym10Mod	00
TxSym32Mod	00
RxBitMod	00
RxEofSym	1D
RxSyncValH	00
RxSyncValL	01
RxSyncMod	00
RxMod	24
RxCorr	40
FabCal	F0

Table 203. Protocol Number 02: ISO/IEC15693 SLI 1/256 - DSC

Value for register	Value (hex)
TxBitMod	00
RFU	00
TxDataCon	83
TxDataMod	04
TxSymFreq	40
TxSym0H	00
TxSym0L	00
TxSym1H	00
TxSym1L	00

Value for register	Value (hex)
TxSym2	81
TxSym3	02
TxSym10Len	00
TxSym32Len	37
TxSym10BurstCtrl	00
TxSym10Mod	00
TxSym32Mod	00
RxBitMod	00
RxEofSym	1D
RxSyncValH	00
RxSyncValL	01
RxSyncMod	00
RxMod	26
RxCorr	60
FabCal	F0

Table 204. Protocol Number 03: EPC/UID - SSC -26

Value for register	Value (hex)
TxBitMod	80
RFU	00
TxDataCon	44
TxDataMod	00
TxSymFreq	44
TxSym0H	08
TxSym0L	22
TxSym1H	08
TxSym1L	28
TxSym2	8A
TxSym3	02
TxSym10Len	BB
TxSym32Len	37
TxSym10BurstCtrl	00
TxSym10Mod	00
TxSym32Mod	00
RxBitMod	08
RxEofSym	0B

Value for register	Value (hex)
RxSyncValH	00
RxSyncValL	00
RxSyncMod	08
RxMod	04
RxCorr	50
FabCal	F0

Table 205. Protocol Number 04: EPC-V2 - 2/424

Value for register	Value (hex)
TxBitMod	80
RFU	00
TxDataCon	C5
TxDataMod	00
TxSymFreq	05
TxSym0H	68
TxSym0L	41
TxSym1H	01
TxSym1L	A1
TxSym2	00
TxSym3	00
TxSym10Len	8E
TxSym32Len	00
TxSym10BurstCtrl	00
TxSym10Mod	00
TxSym32Mod	00
RxBitMod	08
RxEofSym	0B
RxSyncValH	00
RxSyncValL	01
RxSyncMod	04
RxMod	0C
RxCorr	40
FabCal	F0

Table 206. Protocol Number 05: EPC-V2 - 4/424

Value for register	Value (hex)
TxBitMod	80
RFU	00
TxDataCon	C5
TxDataMod	00
TxSymFreq	05
TxSym0H	68
TxSym0L	41
TxSym1H	01
TxSym1L	A1
TxSym2	00
TxSym3	00
TxSym10Len	8E
TxSym32Len	00
TxSym10BurstCtrl	00
TxSym10Mod	00
TxSym32Mod	00
RxBitMod	08
RxEofSym	0B
RxSyncValH	00
RxSyncValL	01
RxSyncMod	04
RxMod	0C
RxCorr	50
FabCal	F0

Table 207. Protocol Number 06: EPC-V2 - 2/848

Value for register	Value (hex)
TxBitMod	80
RFU	00
TxDataCon	C5
TxDataMod	00
TxSymFreq	05
TxSym0H	68
TxSym0L	41
TxSym1H	01
TxSym1L	A1

Value for register	Value (hex)
TxSym2	00
TxSym3	00
TxSym10Len	8E
TxSym32Len	00
TxSym10BurstCtrl	00
TxSym10Mod	00
TxSym32Mod	00
RxBitMod	08
RxEofSym	0B
RxSyncValH	00
RxSyncValL	01
RxSyncMod	04
RxMod	0C
RxCorr	88
FabCal	F0

Table 208. Protocol Number 07: EPC-V2 - 4/848

Value for register	Value (hex)
TxBitMod	80
RFU	00
TxDataCon	C5
TxDataMod	00
TxSymFreq	05
TxSym0H	68
TxSym0L	41
TxSym1H	01
TxSym1L	A1
TxSym2	00
TxSym3	00
TxSym10Len	8E
TxSym32Len	00
TxSym10BurstCtrl	00
TxSym10Mod	00
TxSym32Mod	00
RxBitMod	08
RxEofSym	0B

Value for register	Value (hex)
RxSyncValH	00
RxSyncValL	01
RxSyncMod	04
RxMod	0C
RxCorr	80
FabCal	F0

18.2 SLRC61003 EEPROM configuration

The SLRC61003 user EEPROM had been initialized with useful values for configuration of the chip using a typical 65x65mm antenna. These values stored in EEPROM can be used to configure the MFRC61003 with the command LoadReg. Typically, some of these entries will be required to be modified compared to the preset values to achieve the best RF performance for a specific antenna.

The registers 0x28...0x39 are relevant for configuration of the Antenna. For each supported protocol, a dedicated preset configuration is available. To ensure compatibility between products of the SLRC61003 family, all products use the same default settings which are initialized in EEPROM, even if some of these protocols are not supported by the MFRC61003 product (e.g. ISO/IEC14443-A, ISO14443-B) and cannot be used.

Alternatively, the registers can be initialized by individual register write commands.

Table 209. ISO/IEC14443-A 106 / MIFARE Classic

Value for register	EEPROM address (hex)	Value (hex)
DrvMode	C0	8E
TxAmp	C1	12
DrvCon	C2	39
TxI	C3	0A
TXCrcPreset	C4	18
RXCrcPreset	C5	18
TxDataNum	C6	0F
TxModWidth	C7	21
TxSym10BurstLen	C8	00
TxWaitCtrl	C9	C0
TxWaitLo	CA	12
TxFrameCon	CB	CF
RxSofD	CC	00
RxCtrl	CD	04
RxWait	CE	90
RxTreshold	CF	5C
Rcv	D0	12
RxAAna	D1	0A

Table 210. ISO/IEC14443-A 212/ MIFARE Classic

Value for register	EEPROM address (hex)	Value (hex)
DrvMode	D4	8E
TxAmp	D5	D2
DrvCon	D6	11
TxI	D7	0A
TXCrcPreset	D8	18
RXCrcPreset	D9	18
TxDataNum	DA	0F
TxModWidth	DB	10
TxSym10BurstLen	DC	00
TxWaitCtrl	DD	C0
TxWaitLo	DE	12
TxFrameCon	DF	CF
RxSofD	E0	00
RxCtrl	E1	05
RxWait	E2	90
RxTreshold	E3	3C
Rcv	E4	12
RxAAna	E5	0B

Table 211. ISO/IEC14443-A 424/ MIFARE Classic

Value for register	EEPROM address (hex)	Value (hex)
DrvMode	E8	8F
TxAmp	E9	DE
DrvCon	EA	11
TxI	EB	0F
TXCrcPreset	EC	18
RXCrcPreset	ED	18
TxDataNum	EE	0F
TxModWidth	EF	07
TxSym10BurstLen	F0	00
TxWaitCtrl	F1	C0
TxWaitLo	F2	12
TxFrameCon	F3	CF
RxSofD	F4	00
RxCtrl	F5	06
RxWait	F6	90

Value for register	EEPROM address (hex)	Value (hex)
RxTreshold	F7	2B
Rcv	F8	12
RxAAna	F9	0B

Table 212. ISO/IEC14443-A 848/ MIFARE Classic

Value for register	EEPROM address (hex)	Value (hex)
DrvMode	0100	8F
TxAmp	0101	DB
DrvCon	0102	21
TxI	0103	0F
TXCrcPreset	0104	18
RXCrcPreset	0105	18
TxDataNum	0106	0F
TxModWidth	0107	02
TxSym10BurstLen	0108	00
TxWaitCtrl	0109	C0
TxWaitLo	010A	12
TxFrameCon	010B	CF
RxSofD	010C	00
RxCtrl	010D	07
RxWait	010E	90
RxTreshold	010F	3A
Rcv	0110	12
RxAAna	0111	0B

Table 213. ISO/IEC14443-B 106

Value for register	EEPROM address (hex)	Value (hex)
DrvMode	0114	8F
TxAmp	0115	0E
DrvCon	0116	09
TxI	0117	0A
TXCrcPreset	0118	7B
RXCrcPreset	0119	7B
TxDataNum	011A	08
TxModWidth	011B	00
TxSym10BurstLen	011C	00

Value for register	EEPROM address (hex)	Value (hex)
TxWaitCtrl	011D	01
TxWaitLo	011E	00
TxFrameCon	011F	05
RxSofD	0120	00
RxCtrl	0121	34
RxWait	0122	90
RxTreshold	0123	6F
Rcv	0124	12
RxAAna	0125	03

Table 214. ISO/IEC14443-B 212

Value for register	EEPROM address (hex)	Value (hex)
DrvMode	0128	8F
TxAmp	0129	0E
DrvCon	012A	09
TxI	012B	0A
TXCrcPreset	012C	7B
RXCrcPreset	012D	7B
TxDataNum	012E	08
TxModWidth	012F	00
TxSym10BurstLen	0130	00
TxWaitCtrl	0131	01
TxWaitLo	0132	00
TxFrameCon	0133	05
RxSofD	0134	00
RxCtrl	0135	35
RxWait	0136	90
RxTreshold	0137	3F
Rcv	0138	12
RxAAna	0139	03

Table 215. ISO/IEC14443-B 424

Value for register	EEPROM address (hex)	Value (hex)
DrvMode	0140	8F
TxAmp	0141	0F
DrvCon	0142	09

Value for register	EEPROM address (hex)	Value (hex)
TxI	0143	0A
TXCrcPreset	0144	7B
RXCrcPreset	0145	7B
TxDataNum	0146	08
TxModWidth	0147	00
TxSym10BurstLen	0148	00
TxWaitCtrl	0149	01
TxWaitLo	014A	00
TxFrameCon	014B	05
RxSofD	014C	00
RxCtrl	014D	36
RxWait	014E	90
RxTreshold	014F	3F
Rcv	0150	12
RxAAna	0151	03

Table 216. ISO/IEC14443-B 848

Value for register	EEPROM address (hex)	Value (hex)
DrvMode	0154	8F
TxAmp	0155	10
DrvCon	0156	09
TxI	0157	0A
TXCrcPreset	0158	7B
RXCrcPreset	0159	7B
TxDataNum	015A	08
TxModWidth	015B	00
TxSym10BurstLen	015C	00
TxWaitCtrl	015D	01
TxWaitLo	015E	00
TxFrameCon	015F	05
RxSofD	0160	00
RxCtrl	0161	37
RxWait	0162	90
RxTreshold	0163	3F
Rcv	0164	12
RxAAna	0165	03

The following EEPROM values for initializing the Receiver cannot be used on the MFRC63103. They are provided for compatibility reasons between the products of the CLRC66303 product family

Table 217. JIS X 6319-4 (FeliCa) 212

Value for register	EEPROM address (hex)	Value (hex)
DrvMode	0168	8F
TxAmp	0169	17
DrvCon	016A	01
TxI	016B	06
TXCrcPreset	016C	09
RXCrcPreset	016D	09
TxDataNum	016E	08
TxModWidth	016F	00
TxSym10BurstLen	0170	03
TxWaitCtrl	0171	80
TxWaitLo	0172	12
TxFrameCon	0173	01
RxSofD	0174	00
RxCtrl	0175	05
RxWait	0176	86
RxTreshold	0177	3F
Rcv	0178	12
RxAAna	0179	02

Table 218. JIS X 6319-4 (FeliCa) 424

Value for register	EEPROM address (hex)	Value (hex)
DrvMode	0180	8F
TxAmp	0181	17
DrvCon	0182	01
TxI	0183	06
TXCrcPreset	0184	09
RXCrcPreset	0185	09
TxDataNum	0186	08
TxModWidth	0187	00
TxSym10BurstLen	0188	03
TxWaitCtrl	0189	80
TxWaitLo	018A	12
TxFrameCon	018B	01

Value for register	EEPROM address (hex)	Value (hex)
RxSofD	018C	00
RxCtrl	018D	06
RxWait	018E	86
RxTreshold	018F	3F
Rcv	0190	12
RxAana	0191	02

Table 219. ISO/IEC15693 SLI 1/4 - SSC- 26

Value for register	EEPROM address (hex)	Value (hex)
DrvMode	0194	89
TxAmp	0195	10
DrvCon	0196	09
TxI	0197	0A
TXCrcPreset	0198	7B
RXCrcPreset	0199	7B
TxDataNum	019A	08
TxModWidth	019B	00
TxSym10BurstLen	019C	00
TxWaitCtrl	019D	88
TxWaitLo	019E	A9
TxFrameCon	019F	0F
RxSofD	01A0	00
RxCtrl	01A1	02
RxWait	01A2	9C
RxTreshold	01A3	74
Rcv	01A4	12
RxAana	01A5	07

Table 220. ISO/IEC15693 SLI 1/4 - SSC-53

Value for register	EEPROM address (hex)	Value (hex)
DrvMode	01A8	89
TxAmp	01A9	10
DrvCon	01AA	09
TxI	01AB	0A
TXCrcPreset	01AC	7B
RXCrcPreset	01AD	7B

Value for register	EEPROM address (hex)	Value (hex)
TxDatNum	01AE	08
TxModWidth	016F	00
TxSym10BurstLen	01B0	00
TxWaitCtrl	01B1	88
TxWaitLo	01B2	A9
TxFramCon	01B3	0F
RxSofD	01B4	00
RxCtrl	01B5	03
RxWait	01B6	9C
RxTreshld	01B7	74
Rcv	01B8	12
RxAna	01B9	03

Table 221. ISO/IEC15693 SLI 1/256 - DSC

Value for register	EEPROM address (hex)	Value (hex)
DrvMode	01C0	8E
TxAmp	01C1	10
DrvCon	01C2	01
TxI	01C3	06
TXCrcPreset	01C4	7B
RXCrcPreset	01C5	7B
TxDatNum	01C6	08
TxModWidth	01C7	00
TxSym10BurstLen	01C8	00
TxWaitCtrl	01C9	88
TxWaitLo	01CA	A9
TxFramCon	01CB	0F
RxSofD	01CC	00
RxCtrl	01CD	02
RxWait	01CE	10
RxTreshld	01CF	44
Rcv	01D0	12
RxAna	01D1	06

Table 222. EPC/UID - SSC -26

Value for register	EEPROM address (hex)	Value (hex)
DrvMode	01D4	8F
TxAmp	01D5	10
DrvCon	01D6	01
TxI	01D7	06
TXCrcPreset	01D8	74
RXCrcPreset	01D9	7B
TxDataNum	01DA	18
TxModWidth	01DB	00
TxSym10BurstLen	01DC	00
TxWaitCtrl	01DD	50
TxWaitLo	01DE	5C
TxFrameCon	01DF	0F
RxSofD	01E0	00
RxCtrl	01E1	03
RxWait	01E2	10
RxTreshold	01E3	4E
Rcv	01E4	12
RxAAna	01E5	06

Table 223. EPC-V2 - 2/424

Value for register	EEPROM address (hex)	Value (hex)
DrvMode	01E8	8F
TxAmp	01E9	10
DrvCon	01EA	09
TxI	01EB	0A
TXCrcPreset	01EC	11
RXCrcPreset	01ED	91
TxDataNum	01EE	09
TxModWidth	01EF	00
TxSym10BurstLen	01F0	00
TxWaitCtrl	01F1	80
TxWaitLo	01F2	12
TxFrameCon	01F3	01
RxSofD	01F4	00
RxCtrl	01F5	03
RxWait	01F6	A0

Value for register	EEPROM address (hex)	Value (hex)
RxTreshold	01F7	56
Rcv	01F8	12
RxAAna	01F9	0F

Table 224. EPC-V2 - 4/424

Value for register	EEPROM address (hex)	Value (hex)
DrvMode	0200	8F
TxAmp	0201	10
DrvCon	0202	09
TxI	0203	0A
TXCrcPreset	0204	11
RXCrcPreset	0205	91
TxDataNum	0206	09
TxModWidth	0207	00
TxSym10BurstLen	0208	00
TxWaitCtrl	0209	80
TxWaitLo	020A	12
TxFrameCon	020B	01
RxSofD	020C	00
RxCtrl	020D	03
RxWait	020E	A0
RxTreshold	020F	56
Rcv	0210	12
RxAAna	0211	0F

Table 225. EPC-V2 - 2/848

Value for register	EEPROM address (hex)	Value (hex)
DrvMode	0214	8F
TxAmp	0215	D0
DrvCon	0216	01
TxI	0217	0A
TXCrcPreset	0218	11
RXCrcPreset	0219	91
TxDataNum	021A	09
TxModWidth	021B	00
TxSym10BurstLen	021C	00

Value for register	EEPROM address (hex)	Value (hex)
TxWaitCtrl	021D	80
TxWaitLo	021E	12
TxFrameCon	021F	01
RxSofD	0220	00
RxCtrl	0221	05
RxWait	0222	A0
RxTreshold	0223	26
Rcv	0224	12
RxAAna	0225	0E

Table 226. EPC-V2 - 4/848

Value for register	EEPROM address (hex)	Value (hex)
DrvMode	0228	8F
TxAmp	0229	D0
DrvCon	022A	01
TxI	022B	0A
TXCrcPreset	022C	11
RXCrcPreset	022D	91
TxDataNum	022E	09
TxModWidth	022F	00
TxSym10BurstLen	0230	00
TxWaitCtrl	0231	80
TxWaitLo	0232	12
TxFrameCon	0233	01
RxSofD	0234	00
RxCtrl	0235	05
RxWait	0236	A0
RxTreshold	0237	26
Rcv	0238	12
RxAAna	0239	0E

Table 227. Jewel

Value for register	EEPROM address (hex)	Value (hex)
DrvMode	0240	8E
TxAmp	0241	15
DrvCon	0242	11

Value for register	EEPROM address (hex)	Value (hex)
TxI	0243	06
TXCrcPreset	0244	18
RXCrcPreset	0245	18
TxDataNum	0246	0F
TxModWidth	0247	20
TxSym10BurstLen	0248	00
TxWaitCtrl	0249	40
TxWaitLo	024A	09
TxFrameCon	024B	4F
RxSofD	024C	00
RxCtrl	024D	04
RxWait	024E	8F
RxTreshold	024F	32
Rcv	0250	12
RxAAna	0251	0A

Table 228. ISO/IEC14443 - B 106 EMVCo Optimized

Value for register	EEPROM address (hex)	Value (hex)
DrvMode	0254	8F
TxAmp	0255	0E
DrvCon	0256	09
TxI	0257	0A
TXCrcPreset	0258	7B
RXCrcPreset	0259	7B
TxDataNum	025A	08
TxModWidth	025B	00
TxSym10BurstLen	025C	00
TxWaitCtrl	025D	01
TxWaitLo	025E	00
TxFrameCon	025F	05
RxSofD	0260	00
RxCtrl	0261	34
RxWait	0262	90
RxTreshold	0263	9F
Rcv	0264	12
RxAAna	0265	03

19 Abbreviations

Table 229. Abbreviations

Acronym	Description
ADC	Analog-to-Digital Converter
BPSK	Binary Phase Shift Keying
CRC	Cyclic Redundancy Check
CW	Continuous Wave
EGT	Extra Guard Time
EMC	Electro Magnetic Compatibility
EMD	Electro Magnetic Disturbance
EOF	End Of Frame
EPC	Electronic Product Code
ETU	Elementary Time Unit
GPIO	General Purpose Input/Output
HBM	Human Body Model
I ² C	Inter-Integrated Circuit
IRQ	Interrupt Request
LFO	Low Frequency Oscillator
LPCD	Low-Power Card Detection
LSB	Least Significant Bit
MISO	Master In Slave Out
MOSI	Master Out Slave In
MSB	Most Significant Bit
NRZ	Not Return to Zero
NSS	Not Slave Select
PCD	Proximity Coupling Device
PLL	Phase-Locked Loop
RZ	Return To Zero
RX	Receiver
SAM	Secure Access Module
SOF	Start Of Frame
SPI	Serial Peripheral Interface
SW	Software
TTimer	Timing of the clk period
TX	Transmitter
UART	Universal Asynchronous Receiver Transmitter
UID	Unique IDentification

Acronym	Description
VCO	Voltage Controlled Oscillator

20 References

[1]

Application note AN11019

CLRC663, MFRC630, MFRC631, SLRC610 Antenna Design Guide

[2]

Application note AN11783

CLRC663 plus Low Power Card Detection

21 Revision history

Table 230. Revision history

Document ID	Release date	Data sheet status	Change notice	Supersedes
SLRC610 v. 4.7	20200226	Product data sheet	-	SLRC610 v. 4.6
Modifications:	<ul style="list-style-type: none"> • Section 3 "Applications": added • Section 9.8.1 "DrvMode": changed name of register TxMode to DrvMode • Section 9.15.1 "PadEn": updated register 44h, changed I/O to output 			
SLRC610 v. 4.6	20180912	Product data sheet	-	SLRC610 v. 4.5
Modifications:	<ul style="list-style-type: none"> • Description of Low frequency timer in Section 8.8.3 more detailed now 			
SLRC610 v. 4.5	20180627	Product data sheet	-	SLRC610 v. 4.4
Modifications:	<ul style="list-style-type: none"> • Editorial updates 			
SLRC610 v. 4.4	20171219	Product data sheet	-	SLRC610 v. 4.3
Modifications:	<ul style="list-style-type: none"> • Deleted References to MICORE Application notes 			
SLRC610 v. 4.3	20170801	Product data sheet	-	SLRC610 v. 4.2
Modifications:	<ul style="list-style-type: none"> • Description for new product type SLRC61003 added • Section 20: updated 			
SLRC610 v. 4.2	20160427	Product data sheet	-	SLRC610 v.4.1
Modifications:	<ul style="list-style-type: none"> • Descriptive title changed 			
SLRC610 v. 4.1	20160211	Product data sheet	-	SLRC610 v.3.3
Modifications:	<ul style="list-style-type: none"> • Table Quick reference data: Table notes [3] and [4] removed • Table Characteristics: <ul style="list-style-type: none"> – AVDD and DVDD min and max values added – I_{DD(TVDD)} max value updated to 250 mA • Figure 7 "Connection to host with SPI": updated • Figure 16 "Register read and write access": updated 			
SLRC610 v.3.3	20140204	Product data sheet		SLRC610 v.3.2
Modifications:	<ul style="list-style-type: none"> • PVDD, TVDD data updated • Information on FIFO size corrected • Typing error corrected in description for LPCD • WaterLevel and FIFOLength updated in register overview description • WaterLevel and FIFOLength updated in register FIFOControl • Waterlevel Register updated • FIFOLength Register updated • Pin Out register description corrected 			
SLRC610 v.3.2	20130312	Product data sheet	-	SLRC610 v.3.1
Modifications:	<ul style="list-style-type: none"> • Update of EEPROM content • Descriptive title changed • Table 183 "PinOut register (address 45h): corrected 			
SLRC610 v.3.1	20120906	Product data sheet	-	-

22 Legal information

22.1 Data sheet status

Document status ^{[1][2]}	Product status ^[3]	Definition
Objective [short] data sheet	Development	This document contains data from the objective specification for product development.
Preliminary [short] data sheet	Qualification	This document contains data from the preliminary specification.
Product [short] data sheet	Production	This document contains the product specification.

[1] Please consult the most recently issued document before initiating or completing a design.

[2] The term 'short data sheet' is explained in section "Definitions".

[3] The product status of device(s) described in this document may have changed since this document was published and may differ in case of multiple devices. The latest product status information is available on the Internet at URL <http://www.nxp.com>.

22.2 Definitions

Draft — The document is a draft version only. The content is still under internal review and subject to formal approval, which may result in modifications or additions. NXP Semiconductors does not give any representations or warranties as to the accuracy or completeness of information included herein and shall have no liability for the consequences of use of such information.

Short data sheet — A short data sheet is an extract from a full data sheet with the same product type number(s) and title. A short data sheet is intended for quick reference only and should not be relied upon to contain detailed and full information. For detailed and full information see the relevant full data sheet, which is available on request via the local NXP Semiconductors sales office. In case of any inconsistency or conflict with the short data sheet, the full data sheet shall prevail.

Product specification — The information and data provided in a Product data sheet shall define the specification of the product as agreed between NXP Semiconductors and its customer, unless NXP Semiconductors and customer have explicitly agreed otherwise in writing. In no event however, shall an agreement be valid in which the NXP Semiconductors product is deemed to offer functions and qualities beyond those described in the Product data sheet.

22.3 Disclaimers

Limited warranty and liability — Information in this document is believed to be accurate and reliable. However, NXP Semiconductors does not give any representations or warranties, expressed or implied, as to the accuracy or completeness of such information and shall have no liability for the consequences of use of such information. NXP Semiconductors takes no responsibility for the content in this document if provided by an information source outside of NXP Semiconductors. In no event shall NXP Semiconductors be liable for any indirect, incidental, punitive, special or consequential damages (including - without limitation - lost profits, lost savings, business interruption, costs related to the removal or replacement of any products or rework charges) whether or not such damages are based on tort (including negligence), warranty, breach of contract or any other legal theory. Notwithstanding any damages that customer might incur for any reason whatsoever, NXP Semiconductors' aggregate and cumulative liability towards customer for the products described herein shall be limited in accordance with the Terms and conditions of commercial sale of NXP Semiconductors.

Right to make changes — NXP Semiconductors reserves the right to make changes to information published in this document, including without limitation specifications and product descriptions, at any time and without

notice. This document supersedes and replaces all information supplied prior to the publication hereof.

Suitability for use — NXP Semiconductors products are not designed, authorized or warranted to be suitable for use in life support, life-critical or safety-critical systems or equipment, nor in applications where failure or malfunction of an NXP Semiconductors product can reasonably be expected to result in personal injury, death or severe property or environmental damage. NXP Semiconductors and its suppliers accept no liability for inclusion and/or use of NXP Semiconductors products in such equipment or applications and therefore such inclusion and/or use is at the customer's own risk.

Applications — Applications that are described herein for any of these products are for illustrative purposes only. NXP Semiconductors makes no representation or warranty that such applications will be suitable for the specified use without further testing or modification. Customers are responsible for the design and operation of their applications and products using NXP Semiconductors products, and NXP Semiconductors accepts no liability for any assistance with applications or customer product design. It is customer's sole responsibility to determine whether the NXP Semiconductors product is suitable and fit for the customer's applications and products planned, as well as for the planned application and use of customer's third party customer(s). Customers should provide appropriate design and operating safeguards to minimize the risks associated with their applications and products. NXP Semiconductors does not accept any liability related to any default, damage, costs or problem which is based on any weakness or default in the customer's applications or products, or the application or use by customer's third party customer(s). Customer is responsible for doing all necessary testing for the customer's applications and products using NXP Semiconductors products in order to avoid a default of the applications and the products or of the application or use by customer's third party customer(s). NXP does not accept any liability in this respect.

Limiting values — Stress above one or more limiting values (as defined in the Absolute Maximum Ratings System of IEC 60134) will cause permanent damage to the device. Limiting values are stress ratings only and (proper) operation of the device at these or any other conditions above those given in the Recommended operating conditions section (if present) or the Characteristics sections of this document is not warranted. Constant or repeated exposure to limiting values will permanently and irreversibly affect the quality and reliability of the device.

Terms and conditions of commercial sale — NXP Semiconductors products are sold subject to the general terms and conditions of commercial sale, as published at <http://www.nxp.com/profile/terms>, unless otherwise agreed in a valid written individual agreement. In case an individual agreement is concluded only the terms and conditions of the respective agreement shall apply. NXP Semiconductors hereby expressly objects to applying the customer's general terms and conditions with regard to the purchase of NXP Semiconductors products by customer.

No offer to sell or license — Nothing in this document may be interpreted or construed as an offer to sell products that is open for acceptance or the grant, conveyance or implication of any license under any copyrights, patents or other industrial or intellectual property rights.

Quick reference data — The Quick reference data is an extract of the product data given in the Limiting values and Characteristics sections of this document, and as such is not complete, exhaustive or legally binding.

Export control — This document as well as the item(s) described herein may be subject to export control regulations. Export might require a prior authorization from competent authorities.

Non-automotive qualified products — Unless this data sheet expressly states that this specific NXP Semiconductors product is automotive qualified, the product is not suitable for automotive use. It is neither qualified nor tested in accordance with automotive testing or application requirements. NXP Semiconductors accepts no liability for inclusion and/or use of non-automotive qualified products in automotive equipment or applications. In the event that customer uses the product for design-in and use in automotive applications to automotive specifications and standards, customer (a) shall use the product without NXP Semiconductors' warranty of the product for such automotive applications, use and specifications, and (b) whenever customer uses the product for automotive applications beyond NXP Semiconductors' specifications such use shall be solely at customer's own risk, and (c) customer fully indemnifies NXP Semiconductors for any liability, damages or failed product claims resulting from customer design and use of the product for automotive applications beyond NXP Semiconductors' standard warranty and NXP Semiconductors' product specifications.

Translations — A non-English (translated) version of a document is for reference only. The English version shall prevail in case of any discrepancy between the translated and English versions.

22.4 Licenses

Purchase of NXP ICs with ISO/IEC 14443 type B functionality



RATP/Innovatron Technology

This NXP Semiconductors IC is ISO/IEC 14443 Type B software enabled and is licensed under Innovatron's Contactless Card patents license for ISO/IEC 14443 B.

The license includes the right to use the IC in systems and/or end-user equipment.

Purchase of NXP ICs with NFC technology

Purchase of an NXP Semiconductors IC that complies with one of the Near Field Communication (NFC) standards ISO/IEC 18092 and ISO/IEC 21481 does not convey an implied license under any patent right infringed by implementation of any of those standards. Purchase of NXP Semiconductors IC does not include a license to any NXP patent (or other IP right) covering combinations of those products with other products, whether hardware or software.

22.5 Trademarks

Notice: All referenced brands, product names, service names and trademarks are the property of their respective owners.

I²C-bus — logo is a trademark of NXP B.V.

MIFARE — is a trademark of NXP B.V.

DESFire — is a trademark of NXP B.V.

ICODE and I-CODE — are trademarks of NXP B.V.

MIFARE Plus — is a trademark of NXP B.V.

MIFARE Ultralight — is a trademark of NXP B.V.

MIFARE Classic — is a trademark of NXP B.V.

Tables

Tab. 1.	Quick reference data SLRC61002HN	4	Tab. 46.	HostCtrl register (address 01h);	56
Tab. 2.	Quick reference data SLRC61003HN	4	Tab. 47.	HostCtrl bits	57
Tab. 3.	Ordering information	5	Tab. 48.	FIFOControl register (address 02h);	57
Tab. 4.	Pin description	7	Tab. 49.	FIFOControl bits	57
Tab. 5.	Interrupt sources	10	Tab. 50.	WaterLevel register (address 03h);	58
Tab. 6.	Communication overview for ISO/IEC 15693 reader/writer reader to label	13	Tab. 51.	WaterLevel bits	58
Tab. 7.	Communication overview for ISO/IEC 15693 reader/writer label to reader	13	Tab. 52.	FIFOLength register (address 04h); reset value: 00h	59
Tab. 8.	Communication overview for EPC/UID	14	Tab. 53.	FIFOLength bits	59
Tab. 9.	Connection scheme for detecting the different interface types	15	Tab. 54.	FIFOData register (address 05h);	59
Tab. 10.	Byte Order for MOSI and MISO	16	Tab. 55.	FIFOData bits	59
Tab. 11.	Byte Order for MOSI and MISO	17	Tab. 56.	IRQ0 register (address 06h); reset value: 00h	60
Tab. 12.	Address byte 0 register; address MOSI	17	Tab. 57.	IRQ0 bits	60
Tab. 13.	Timing conditions SPI	17	Tab. 58.	IRQ1 register (address 07h)	60
Tab. 14.	Settings of BR_T0 and BR_T1	18	Tab. 59.	IRQ1 bits	61
Tab. 15.	Selectable transfer speeds	18	Tab. 60.	IRQ0En register (address 08h)	61
Tab. 16.	UART framing	19	Tab. 61.	IRQ0En bits	61
Tab. 17.	Byte Order to Read Data	19	Tab. 62.	IRQ1EN register (address 09h);	62
Tab. 18.	Byte Order to Write Data	20	Tab. 63.	IRQ1EN bits	62
Tab. 19.	Timing parameter I2CL	25	Tab. 64.	Error register (address 0Ah)	62
Tab. 20.	SPI SAM connection	26	Tab. 65.	Error bits	62
Tab. 21.	Boundary scan command	27	Tab. 66.	Status register (address 0Bh)	63
Tab. 22.	Boundary scan path of the SLRC610	29	Tab. 67.	Status bits	64
Tab. 23.	Settings for TX1 and TX2	33	Tab. 68.	RxBitCtrl register (address 0Ch);	64
Tab. 24.	Setting residual carrier and modulation index by TXamp.set_residual_carrier	33	Tab. 69.	RxBitCtrl bits	64
Tab. 25.	Configuration for single or differential receiver	36	Tab. 70.	RxColl register (address 0Dh);	65
Tab. 26.	Register configuration of SLRC610 active antenna concept (DIGITAL)	37	Tab. 71.	RxColl bits	65
Tab. 27.	Register configuration of SLRC610 active antenna concept (Antenna)	37	Tab. 72.	TControl register (address 0Eh)	65
Tab. 28.	EEPROM memory organization	41	Tab. 73.	TControl bits	66
Tab. 29.	Production area (Page 0)	41	Tab. 74.	T0Control register (address 0Fh);	66
Tab. 30.	Product ID overview of CLRC663 family	42	Tab. 75.	T0Control bits	66
Tab. 31.	Configuration area (Page 0)	42	Tab. 76.	T0ReloadHi register (address 10h);	67
Tab. 32.	Interface byte	42	Tab. 77.	T0ReloadHi bits	67
Tab. 33.	Interface bits	42	Tab. 78.	T0ReloadLo register (address 11h);	67
Tab. 34.	Tx and Rx arrangements in the register set protocol area	43	Tab. 79.	T0ReloadLo bits	67
Tab. 35.	Register reset values (Hex.) (Page0)	43	Tab. 80.	T0CounterValHi register (address 12h)	68
Tab. 36.	Register reset values (Hex.)(Page1 and page 2)	44	Tab. 81.	T0CounterValHi bits	68
Tab. 37.	Crystal requirements recommendations	45	Tab. 82.	T0CounterValLo register (address 13h)	68
Tab. 38.	Divider values for selected frequencies using the integerN PLL	46	Tab. 83.	T0CounterValLo bits	68
Tab. 39.	Command set	49	Tab. 84.	T1Control register (address 14h);	68
Tab. 40.	Predefined protocol overview RX	51	Tab. 85.	T1Control bits	68
Tab. 41.	Predefined protocol overview TX	52	Tab. 86.	T0ReloadHi register (address 15h)	69
Tab. 42.	Behavior of register bits and their designation	53	Tab. 87.	T1ReloadHi bits	69
Tab. 43.	SLRC610 registers overview	53	Tab. 88.	T1ReloadLo register (address 16h)	69
Tab. 44.	Command register (address 00h)	56	Tab. 89.	T1ReloadValLo bits	70
Tab. 45.	Command bits	56	Tab. 90.	T1CounterValHi register (address 17h)	70
			Tab. 91.	T1CounterValHi bits	70
			Tab. 92.	T1CounterValLo register (address 18h)	70
			Tab. 93.	T1CounterValLo bits	70
			Tab. 94.	T2Control register (address 19h)	70
			Tab. 95.	T2Control bits	71
			Tab. 96.	T2ReloadHi register (address 1Ah)	71
			Tab. 97.	T2Reload bits	71
			Tab. 98.	T2ReloadLo register (address 1Bh)	71
			Tab. 99.	T2ReloadLo bits	72

Tab. 100. T2CounterValHi register (address 1Ch)	72	Tab. 158. RxAna register (address 39h)	86
Tab. 101. T2CounterValHi bits	72	Tab. 159. RxAna bits	86
Tab. 102. T2CounterValLo register (address 1Dh)	72	Tab. 160. Effect of gain and highpass corner register settings	87
Tab. 103. T2CounterValLo bits	72	Tab. 161. SerialSpeed register (address3Bh); reset value: 7Ah	87
Tab. 104. T3Control register (address 1Eh)	72	Tab. 162. SerialSpeed bits	88
Tab. 105. T3Control bits	73	Tab. 163. RS232 speed settings	88
Tab. 106. T3ReloadHi register (address 1Fh);	73	Tab. 164. LFO_Trim register (address 3Ch)	88
Tab. 107. T3ReloadHi bits	73	Tab. 165. LFO_Trim bits	88
Tab. 108. T3ReloadLo register (address 20h)	73	Tab. 166. PLL_Ctrl register (address3Dh)	89
Tab. 109. T3ReloadLo bits	74	Tab. 167. PLL_Ctrl register bits	89
Tab. 110. T3CounterValHi register (address 21h)	74	Tab. 168. Setting of feedback divider PLLDiv_FB [1:0] ...	89
Tab. 111. T3CounterValHi bits	74	Tab. 169. PLLDiv_Out register (address 3Eh)	89
Tab. 112. T3CounterValLo register (address 22h)	74	Tab. 170. PLLDiv_Out bits	90
Tab. 113. T3CounterValLo bits	74	Tab. 171. Setting for the output divider ratio PLLDiv_Out [7:0]	90
Tab. 114. T4Control register (address 23h)	74	Tab. 172. LPCD_QMin register (address 3Fh)	90
Tab. 115. T4Control bits	75	Tab. 173. LPCD_QMin bits	90
Tab. 116. T4ReloadHi register (address 24h)	75	Tab. 174. LPCD_QMax register (address 40h)	91
Tab. 117. T4ReloadHi bits	76	Tab. 175. LPCD_QMax bits	91
Tab. 118. T4ReloadLo register (address 25h)	76	Tab. 176. LPCD_IMin register (address 41h)	91
Tab. 119. T4ReloadLo bits	76	Tab. 177. LPCD_IMin bits	91
Tab. 120. T4CounterValHi register (address 26h)	76	Tab. 178. LPCD_Result_I register (address 42h)	92
Tab. 121. T4CounterValHi bits	76	Tab. 179. LPCD_I_Result bits	92
Tab. 122. T4CounterValLo register (address 27h)	76	Tab. 180. LPCD_Result_Q register (address 43h)	92
Tab. 123. T4CounterValLo bits	77	Tab. 181. LPCD_Q_Result bits	92
Tab. 124. DrvMode register (address 28h)	77	Tab. 182. LPCD_Options register (address 3Ah)	92
Tab. 125. DrvMode bits	77	Tab. 183. LPCD_Options	93
Tab. 126. TxAmp register (address 29h)	77	Tab. 184. PadEn register (address 44h)	93
Tab. 127. TxAmp bits	78	Tab. 185. PadEn bits	93
Tab. 128. TxCon register (address 2Ah)	78	Tab. 186. PadOut register (address 45h)	94
Tab. 129. TxCon bits	78	Tab. 187. PadOut bits	94
Tab. 130. TxI register (address 2Bh)	78	Tab. 188. PadIn register (address 46h)	94
Tab. 131. TxI bits	79	Tab. 189. PadIn bits	95
Tab. 132. TXCrcPreset register (address 2Ch)	79	Tab. 190. SigOut register (address 47h)	95
Tab. 133. TXCrcPreset bits	79	Tab. 191. SigOut bits	95
Tab. 134. Transmitter CRC preset value configuration ...	79	Tab. 192. Version register (address 7Fh)	96
Tab. 135. RxCrcCon register (address 2Dh)	80	Tab. 193. Version bits	96
Tab. 136. RxCrcCon bits	80	Tab. 194. Limiting values	97
Tab. 137. Receiver CRC preset value configuration	80	Tab. 195. Operating conditions SLRC61002HN	98
Tab. 138. TxDataNum register (address 2Eh)	81	Tab. 196. Operating conditions SLRC61003HN	98
Tab. 139. TxDataNum bits	81	Tab. 197. Thermal characteristics	99
Tab. 140. TxSym10BurstLen register (address 30h)	81	Tab. 198. Characteristics	100
Tab. 141. TxSym10BurstLen bits	81	Tab. 199. SPI timing characteristics	103
Tab. 142. TxWaitCtrl register (address 31h); reset value: C0h	82	Tab. 200. I2C-bus timing in fast mode and fast mode plus	103
Tab. 143. TXWaitCtrl bits	82	Tab. 201. Protocol Number 00: ISO/IEC15693 SLI 1/4 - SSC- 26	116
Tab. 144. TxWaitLo register (address 32h)	83	Tab. 202. Protocol Number 01: ISO/IEC15693 SLI 1/4 - SSC- 53	117
Tab. 145. TxWaitLo bits	83	Tab. 203. Protocol Number 02: ISO/IEC15693 SLI 1/256 - DSC	117
Tab. 146. FrameCon register (address 33h)	83	Tab. 204. Protocol Number 03: EPC/UID - SSC -26	118
Tab. 147. FrameCon bits	83	Tab. 205. Protocol Number 04: EPC-V2 - 2/424	119
Tab. 148. RxSofD register (address 34h)	84	Tab. 206. Protocol Number 05: EPC-V2 - 4/424	120
Tab. 149. RxSofD bits	84	Tab. 207. Protocol Number 06: EPC-V2 - 2/848	120
Tab. 150. RxCtrl register (address 35h)	84	Tab. 208. Protocol Number 07: EPC-V2 - 4/848	121
Tab. 151. RxCtrl bits	84	Tab. 209. ISO/IEC14443-A 106 / MIFARE Classic	122
Tab. 152. RxWait register (address 36h)	85		
Tab. 153. RxWait bits	85		
Tab. 154. RxThreshold register (address 37h)	85		
Tab. 155. RxThreshold bits	85		
Tab. 156. Rcv register (address 38h)	85		
Tab. 157. Rcv bits	86		

Tab. 210. ISO/IEC14443-A 212/ MIFARE Classic	123	Tab. 221. ISO/IEC15693 SLI 1/256 - DSC	129
Tab. 211. ISO/IEC14443-A 424/ MIFARE Classic	123	Tab. 222. EPC/UID - SSC -26	130
Tab. 212. ISO/IEC14443-A 848/ MIFARE Classic	124	Tab. 223. EPC-V2 - 2/424	130
Tab. 213. ISO/IEC14443-B 106	124	Tab. 224. EPC-V2 - 4/424	131
Tab. 214. ISO/IEC14443-B 212	125	Tab. 225. EPC-V2 - 2/848	131
Tab. 215. ISO/IEC14443-B 424	125	Tab. 226. EPC-V2 - 4/848	132
Tab. 216. ISO/IEC14443-B 848	126	Tab. 227. Jewel	132
Tab. 217. JIS X 6319-4 (FeliCa) 212	127	Tab. 228. ISO/IEC14443 - B 106 EMVCo Optimized	133
Tab. 218. JIS X 6319-4 (FeliCa) 424	127	Tab. 229. Abbreviations	134
Tab. 219. ISO/IEC15693 SLI 1/4 - SSC- 26	128	Tab. 230. Revision history	137
Tab. 220. ISO/IEC15693 SLI 1/4 - SSC-53	128		

Figures

Fig. 1.	Simplified block diagram of the SLRC610	6	Fig. 19.	Example 1: overshoot_t1 = 2d; overhoot_t2 = 5d.	34
Fig. 2.	Pinning configuration HVQFN32 (SOT617-1)	7	Fig. 20.	Example 2: overshoot_t1 = 0d; overhoot_t2 = 5d	35
Fig. 3.	Detailed block diagram of the SLRC610	9	Fig. 21.	Block diagram of receiver circuitry	36
Fig. 4.	Read/write mode	13	Fig. 22.	Block diagram of the active Antenna concept	37
Fig. 5.	Data coding according to ISO/IEC 15693. standard mode reader to label	14	Fig. 23.	Overview SIGIN/SIGOUT Signal Routing	39
Fig. 6.	Connection to host with SPI	16	Fig. 24.	Sector arrangement of the EEPROM	41
Fig. 7.	Connection to host with SPI	18	Fig. 25.	Quartz connection	45
Fig. 8.	Example for UART Read	20	Fig. 26.	Internal PDown to voltage regulator logic	48
Fig. 9.	Example diagram for a UART write	20	Fig. 27.	Pin RX input voltage	103
Fig. 10.	I2C-bus interface	21	Fig. 28.	Timing for fast and standard mode devices on the I2C-bus	104
Fig. 11.	Bit transfer on the I2C-bus.	21	Fig. 29.	Typical application antenna circuit diagram	105
Fig. 12.	START and STOP conditions	22	Fig. 30.	Package outline SOT617-1 (HVQFN32)	108
Fig. 13.	Acknowledge on the I2C- bus	23	Fig. 31.	Packing information 1 tray	111
Fig. 14.	Data transfer on the I2C- bus	23	Fig. 32.	Packing information 5 tray	112
Fig. 15.	First byte following the START procedure	23	Fig. 33.	Tray details	113
Fig. 16.	Register read and write access	25	Fig. 34.	Packing information Reel	114
Fig. 17.	Boundary scan cell path structure	29			
Fig. 18.	General dependences of modulation	32			

Contents

1	General description	1	8.4.6.9	Boundary Scan Description Language (BSDL)	30
2	Features and benefits	2	8.4.6.10	Non-IEEE1149.1 commands	30
3	Applications	3	8.5	Buffer	30
4	Quick reference data	4	8.5.1	Overview	30
5	Ordering information	5	8.5.2	Accessing the FIFO buffer	31
6	Block diagram	6	8.5.3	Controlling the FIFO buffer	31
7	Pinning information	7	8.5.4	Status Information about the FIFO buffer	31
7.1	Pin description	7	8.6	Analog interface and contactless UART	32
8	Functional description	9	8.6.1	General	32
8.1	Interrupt controller	9	8.6.2	TX transmitter	32
8.2	Timer module	11	8.6.2.1	Overshoot protection	34
8.2.1	Timer modes	11	8.6.2.2	Bit generator	35
8.2.1.1	Time-Out- and Watch-Dog-Counter	12	8.6.3	Receiver circuitry	35
8.2.1.2	Wake-up timer	12	8.6.3.1	General	35
8.2.1.3	Stop watch	12	8.6.3.2	Block diagram	35
8.2.1.4	Programmable one-shot timer	12	8.6.4	Active antenna concept	37
8.2.1.5	Periodical trigger	12	8.6.5	Symbol generator	40
8.3	Contactless interface unit	13	8.7	Memory	40
8.3.1	ISO/IEC15693 functionality	13	8.7.1	Memory overview	40
8.3.2	EPC-UID/UID-OTP functionality	14	8.7.2	EEPROM memory organization	40
8.3.3	ISO/IEC 18000-3 mode 3/ EPC Class-1 HF functionality	14	8.7.2.1	Product information and configuration - Page 0	41
8.3.3.1	Data encoding ICODE	15	8.7.3	EEPROM initialization content LoadProtocol ...	43
8.4	Host interfaces	15	8.8	Clock generation	45
8.4.1	Host interface configuration	15	8.8.1	Crystal oscillator	45
8.4.2	SPI interface	15	8.8.2	IntegerN PLL clock line	45
8.4.2.1	General	16	8.8.3	Low Frequency Oscillator (LFO)	46
8.4.2.2	Read data	16	8.9	Power management	47
8.4.2.3	Write data	16	8.9.1	Supply concept	47
8.4.2.4	Address byte	17	8.9.2	Power reduction mode	47
8.4.2.5	Timing Specification SPI	17	8.9.2.1	Power-down	47
8.4.3	RS232 interface	18	8.9.2.2	Standby mode	47
8.4.3.1	Selection of the transfer speeds	18	8.9.2.3	Modem off mode	48
8.4.3.2	Framing	19	8.9.3	Low-Power Card Detection (LPCD)	48
8.4.4	I2C-bus interface	20	8.9.4	Reset and start-up time	48
8.4.4.1	General	20	8.10	Command set	48
8.4.4.2	I2C Data validity	21	8.10.1	General	49
8.4.4.3	I2C START and STOP conditions	21	8.10.2	Command set overview	49
8.4.4.4	I2C byte format	22	8.10.3	Command functionality	49
8.4.4.5	I2C Acknowledge	22	8.10.3.1	Idle command	49
8.4.4.6	I2C 7-bit addressing	23	8.10.3.2	LPCD command	50
8.4.4.7	I2C-register write access	24	8.10.3.3	AckReq command	50
8.4.4.8	I2C-register read access	24	8.10.3.4	Receive command	50
8.4.4.9	I2CL-bus interface	25	8.10.3.5	Transmit command	50
8.4.5	SAM interface	26	8.10.3.6	Transceive command	50
8.4.5.1	SAM functionality	26	8.10.3.7	WriteE2 command	50
8.4.5.2	SAM connection	26	8.10.3.8	WriteE2PAGE command	51
8.4.6	Boundary scan interface	27	8.10.3.9	ReadE2 command	51
8.4.6.1	Interface signals	27	8.10.3.10	LoadReg command	51
8.4.6.2	Test Clock (TCK)	27	8.10.3.11	LoadProtocol command	51
8.4.6.3	Test Mode Select (TMS)	28	8.10.3.12	GetRNR command	52
8.4.6.4	Test Data Input (TDI)	28	8.10.3.13	SoftReset command	52
8.4.6.5	Test Data Output (TDO)	28	9	SLRC610 registers	53
8.4.6.6	Data register	28	9.1	Register bit behavior	53
8.4.6.7	Boundary scan cell	28	9.2	Command configuration	56
8.4.6.8	Boundary scan path	29			

9.2.1	Command	56	9.10.3	TxWaitCtrl	82
9.3	SAM configuration register	56	9.10.4	TxWaitLo	83
9.3.1	HostCtrl	56	9.11	FrameCon	83
9.4	FIFO configuration register	57	9.12	Receiver configuration registers	83
9.4.1	FIFOControl	57	9.12.1	RxSofD	84
9.4.2	WaterLevel	58	9.12.2	RxCtrl	84
9.4.3	FIFOLength	58	9.12.3	RxWait	85
9.4.4	FIFOData	59	9.12.4	RxThreshold	85
9.5	Interrupt configuration registers	59	9.12.5	Rcv	85
9.5.1	IRQ0 register	60	9.12.6	RxAنا	86
9.5.2	IRQ1 register	60	9.13	Clock configuration	87
9.5.3	IRQ0En register	61	9.13.1	SerialSpeed	87
9.5.4	IRQ1En	61	9.13.2	LFO_Trimm	88
9.6	Contactless interface configuration registers	62	9.13.3	PLL_Ctrl Register	88
9.6.1	Error	62	9.13.4	PLLDiv_Out	89
9.6.2	Status	63	9.14	Low-power card detection configuration registers	90
9.6.3	RxBitCtrl	64	9.14.1	LPCD_QMin	90
9.6.4	RxColl	65	9.14.2	LPCD_QMax	91
9.7	Timer configuration registers	65	9.14.3	LPCD_IMin	91
9.7.1	TControl	65	9.14.4	LPCD_Result_I	92
9.7.2	T0Control	66	9.14.5	LPCD_Result_Q	92
9.7.2.1	T0ReloadHi	67	9.14.6	LPCD_Options	92
9.7.2.2	T0ReloadLo	67	9.15	Pin configuration	93
9.7.2.3	T0CounterValHi	67	9.15.1	PadEn	93
9.7.2.4	T0CounterValLo	68	9.15.2	PadOut	94
9.7.2.5	T1Control	68	9.15.3	PadIn	94
9.7.2.6	T1ReloadHi	69	9.15.4	SigOut	95
9.7.2.7	T1ReloadLo	69	9.16	Version register	95
9.7.2.8	T1CounterValHi	70	9.16.1	Version	96
9.7.2.9	T1CounterValLo	70	10	Limiting values	97
9.7.2.10	T2Control	70	11	Recommended operating conditions	98
9.7.2.11	T2ReloadHi	71	12	Thermal characteristics	99
9.7.2.12	T2ReloadLo	71	13	Characteristics	100
9.7.2.13	T2CounterValHi	72	13.1	Timing characteristics	103
9.7.2.14	T2CounterValLoReg	72	14	Application information	105
9.7.2.15	T3Control	72	14.1	Antenna design description	105
9.7.2.16	T3ReloadHi	73	14.1.1	EMC low pass filter	105
9.7.2.17	T3ReloadLo	73	14.1.2	Antenna matching	106
9.7.2.18	T3CounterValHi	74	14.1.3	Receiving circuit	106
9.7.2.19	T3CounterValLo	74	14.1.4	Antenna coil	106
9.7.2.20	T4Control	74	15	Package outline	108
9.7.2.21	T4ReloadHi	75	16	Handling information	110
9.7.2.22	T4ReloadLo	76	17	Packing information	111
9.7.2.23	T4CounterValHi	76	18	Appendix	116
9.7.2.24	T4CounterValLo	76	18.1	LoadProtocol command register initialization	116
9.8	Transmitter driver configuration registers	77	18.2	SLRC61003 EEPROM configuration	122
9.8.1	DrvMode	77	19	Abbreviations	134
9.8.2	TxAmp	77	20	References	136
9.8.3	TxCon	78	21	Revision history	137
9.8.4	Txl	78	22	Legal information	138
9.9	Transmitter CRC configuration registers	79			
9.9.1	TxCrcPreset	79			
9.9.2	RxCrcCon	80			
9.10	Transmitter data configuration registers	80			
9.10.1	TxDatNum	81			
9.10.2	TxSym10BurstLen	81			

Please be aware that important notices concerning this document and the product(s) described herein, have been included in section 'Legal information'.

© NXP B.V. 2020.

All rights reserved.

For more information, please visit: <http://www.nxp.com>

For sales office addresses, please send an email to: salesaddresses@nxp.com

Date of release: 26 February 2020

Document identifier: SLRC610

Document number: 227647



Стандарт Электрон Связь

Мы молодая и активно развивающаяся компания в области поставок электронных компонентов. Мы поставляем электронные компоненты отечественного и импортного производства напрямую от производителей и с крупнейших складов мира.

Благодаря сотрудничеству с мировыми поставщиками мы осуществляем комплексные и плановые поставки широчайшего спектра электронных компонентов.

Собственная эффективная логистика и склад в обеспечивает надежную поставку продукции в точно указанные сроки по всей России.

Мы осуществляем техническую поддержку нашим клиентам и предпродажную проверку качества продукции. На все поставляемые продукты мы предоставляем гарантию .

Осуществляем поставки продукции под контролем ВП МО РФ на предприятия военно-промышленного комплекса России , а также работаем в рамках 275 ФЗ с открытием отдельных счетов в уполномоченном банке. Система менеджмента качества компании соответствует требованиям ГОСТ ISO 9001.

Минимальные сроки поставки, гибкие цены, неограниченный ассортимент и индивидуальный подход к клиентам являются основой для выстраивания долгосрочного и эффективного сотрудничества с предприятиями радиоэлектронной промышленности, предприятиями ВПК и научно-исследовательскими институтами России.

С нами вы становитесь еще успешнее!

Наши контакты:

Телефон: +7 812 627 14 35

Электронная почта: sales@st-electron.ru

Адрес: 198099, Санкт-Петербург,
Промышленная ул, дом № 19, литера Н,
помещение 100-Н Офис 331