

Power Supply, Primary Switch Mode, Narrow Design MINI-PS-100-240AC/5DC/3

MINI POWER provides:

- **Extra narrow** widths of 22.5 and 45 mm (0.886 and 1.772 in.)
- **Global use** due to a wide range input
- **A high level of operational safety** in complex global networks
- **Reliable start up** of heavy loads due to POWER BOOST

The reliability of a power supply determines the availability of individual components in a system and whether complex systems can function safely.

The globalization of markets increases the demands placed on the power supply. A wide range input and a high level of availability are required. These requirements are met by MINI POWER.

1. Brief Description

MINI POWER is the extra narrow power supply, which is available in widths of 22.5 and 45 mm (0.886 and 1.772 in.).

In addition to a 24 V version with output currents of 0.65 A and 2 A, special voltages are also available with 5 V/3 A and +/- 15 V/1 A.

The POWER BOOST - a power reserve of up to 100% - ensures a reliable start of difficult loads.

The high level of operational safety is also ensured in complex global networks. MINI POWER also operates in applications where static voltage dips, transient power supply failures or phase failure are common.

Large capacitors ensure mains buffering of more than 20 ms at full load.



2. Area of Application

MINI POWER can be used globally due to the consistent conversion of a wide range input.

In this way, your entire system can be tested at any production location in the world and can be delivered to any location in the world without faulty switching of the input voltage. This reduces storage costs and logistical effort.

An international approval package including UL 60950 for IT equipment and UL 508 for industrial control equipment enables the device to be used globally.

3. Technical Data

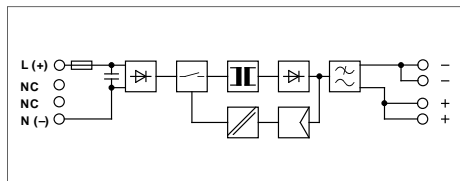

MINI-PS-100-240AC/5DC/3

8 mm (0.31 in.) 	solid	flexible		torque
	[mm ²]	AWG		[Nm]
Input	0.2 - 2.5	0.2 - 2.5	24 - 14	0.5 - 0.6
Output	0.2 - 2.5	0.2 - 2.5	24 - 14	0.5 - 0.6

1 AC



Description

Power Supply,
primary switch mode, narrow design

Type

MINI-PS-100-240AC/5DC/3

Order No.

29 38 71 4

Pcs.
Pkt.

1

Technical Data

Input Data ①

Nominal input voltage
Input voltage range
Frequency
Current consumption (for nominal values)
Inrush current limiting/ I^2t (+25°C [+77°F])
Mains buffering for a nominal load (typical)
Switch-on time after applying the AC supply voltage
Transient surge protection
Input fuse, internal
Recommended fuse

100 - 240 V AC (wide range input)
85 - 264 V AC (0.4-0.2 A) 90 - 350 V DC (0.4-0.2 A)
45 - 65 Hz 0 Hz
0.2 A (120 V AC) - 0.4 A (230 V AC), approximately
< 25 A/< 1.5 A²s, typical
> 20 ms (120 V AC)/> 100 ms (230 V AC)
< 1 s
Varistor
2 AT (device protection)
Circuit breaker 10 A or 16 A
Characteristic B (EN 60 898)

Output Data ②

Nominal output voltage U_N /tolerance
Setting range for the output voltage
Output current during convection cooling and nominal values
POWER BOOST I_{BOOST} (t = 2, minutes [typical])
Nominal output current I_N -25°C to +60°C (-13°F to +140°F)
Derating
Short-circuit current limit
Startup of capacitive loads
System deviation on:
Load change static 10 - 90%
Load change dynamic 10 - 90%
Input voltage change ±10%
No load/nominal load
Maximum power loss
Level of efficiency (typical)
Response time U_{OUT} (10% - 90%)
Residual ripple/switching peaks (20 MHz)
Can be connected in parallel
Internal surge protection
Resistance to return supply



5 V DC/±1%
4.5 - 5.5 V DC
Up to 6 A ($U_{out} = 5$ V DC)
3 A ($U_{out} = 5$ V DC)
From +60°C (+140°F), 5% per Kelvin
 $I_{BOOST} \approx 6$ A, approximately
Unlimited
< 1%, typical
< 3%, typical
< 0.1%, typical
1.7 W/5 W
> 73% (for 230 V AC and nominal values)
< 100 ms, typical
< 100 mV_{pp} (for nominal values)
To increase redundancy and power
Yes, limited to 20 V DC, approximately
6 V DC

Signal Output Data

LED ($U_{out} > 4$ V DC $\hat{=}$ LED permanently on)

Green LED

Power Supply, Primary Switch Mode, Narrow Design – MINI-PS-100-240AC/5DC/3

General Data		
Isolation voltage:	Input/output	4 kV AC (type test)/3 kV AC (routine test)
Approval package		EN 61 558-2-17
Safety transformers for switched-mode power supplies		EN 60950/VDE 0805
Electrical safety (of IT equipment)		UL/C-UL Recognized UL 60 950  ¹⁾
Industrial control equipment		UL/C-UL Listed UL 508  ¹⁾
Equipping high voltage installations with electronic equipment		EN 50 178/VDE 0160 (Surge Voltage Category III)
Safety extra-low voltage		PELV (EN 50 178)
		SELV (EN 60 950)
		VDE 0100-410
		DIN 57 100-410
Safe isolation		
Protection against electric shock		
Protection against dangerous shock currents, basic requirements for safe isolation in electrical equipment		DIN VDE 0106-101
Limitation of harmonic line currents		According to EN 61000-3-2
Mounting position		On horizontal NS 35 DIN rail according to EN 50022
Can be mounted with spacing	- Vertical - Horizontal	≥ 8 cm (0.31 in.)
Degree of protection		0 cm
Class of protection		IP 20
MTBF		II, (in closed control cabinets)
Housing version		> 500 000 h according to IEC 1709 (SN 29 500)
Dimensions (W x H x D)		Polyamide PA, color green
Weight		(22.5 x 99 x 114.5 mm [0.886 x 3.898 x 4.508 in.])
		0.17 kg, approximately

Climatic Data		
Ambient temperature	Operation Storage	-25°C to +70°C (-13°F to +158°F) (> +60°C [+140°F] derating)
Humidity		-40°C to +85°C (-40°F to +185°F)
Vibration		up to 95% at +25°C (+77°F), no condensation
Shock	according to IEC 68-2-6	< 15 Hz, amplitude ±2.5 mm/15 Hz - 150 Hz, 2.3 g
Degree of pollution	according to IEC 68-2-27	30 g all space directions
Climatic category		2 (according to EN 50 178)
		3K3 (according to EN 60 721)



Conforms to the EMC Directive 89/336/EEC and the Low Voltage Directive 73/23/EEC

EMC (Electromagnetic Compatibility) Noise Immunity According to EN 61000-6-2:

Electrostatic discharge (ESD)	EN 61000-4-2 ³⁾	Housing Contact discharge: Air discharge:
Electromagnetic HF field	EN 61000-4-3 ²⁾	Housing Frequency: Field strength:
Fast transients (burst)	EN 61000-4-4 ³⁾	Input: Output:
Surge current loads	EN 61000-4-5 ³⁾	Input: Output:
Conducted interference	EN 61000-4-6 ²⁾	I/O: Frequency: U ₀ :
Voltage dips	EN 61000-4-11 ³⁾	Input:
Simulation of radiophone	EN 50204	Frequency: Field strength:

Noise Emission According to EN 50081-2:

Radio interference	EN 55011
Radio interference	EN 55011

EN 55011 corresponds to CISPR11/EN 55022 corresponds to CISPR22
EN 61000 corresponds to IEC 1000

²⁾Criterion A: Normal operating characteristics within the specified limits.

³⁾Criterion B: Temporary adverse effects on the operating characteristics that the device corrects

¹⁾ UL approval for AC input voltage and ambient temperature up to +60°C (+140°F)

Requirements EN 61 000-6-2	MINI-PS-100-240AC/5DC/3
4 kV	Level 3
8 kV	8 kV
8 kV	8 kV
80 - 1000 MHz	Level 3
10 V/m	80 - 1000 MHz/1.4 - 2.0 GHz
2 kV	10 V/m
2 kV	4 kV (Level 4)
2 kV	2 kV (Level 3)
2 kV	2 kV (Level 3)
1 kV	1 kV (Level 3)
0.5 kV	0.5 kV (Level 1)
0.5 kV	0.5 kV (Level 1)
0.5 kV	0.5 kV (Level 1)
0.5 kV	0.5 kV (Level 1)
0.15 - 80 MHz	Level 3
10 V	0.15 - 80 MHz
10 V	10 V
30% reduction of the input voltage for 0.5 periods	See input data: Mains buffering > 20 ms
Not required	900 MHz/1800 MHz
	20 V/m
Class A ⁶⁾	EN 55011 (EN 55022) Class B ⁷⁾
Class A ⁶⁾	EN 55011 (EN 55022) Class B ⁷⁾

⁴⁾symmetrical: Cable to cable

⁵⁾asymmetrical: Cable to ground

⁶⁾Class A: Industrial application

⁷⁾Class B: Industrial and domestic applications

4. Device View, Connections, and Control Elements

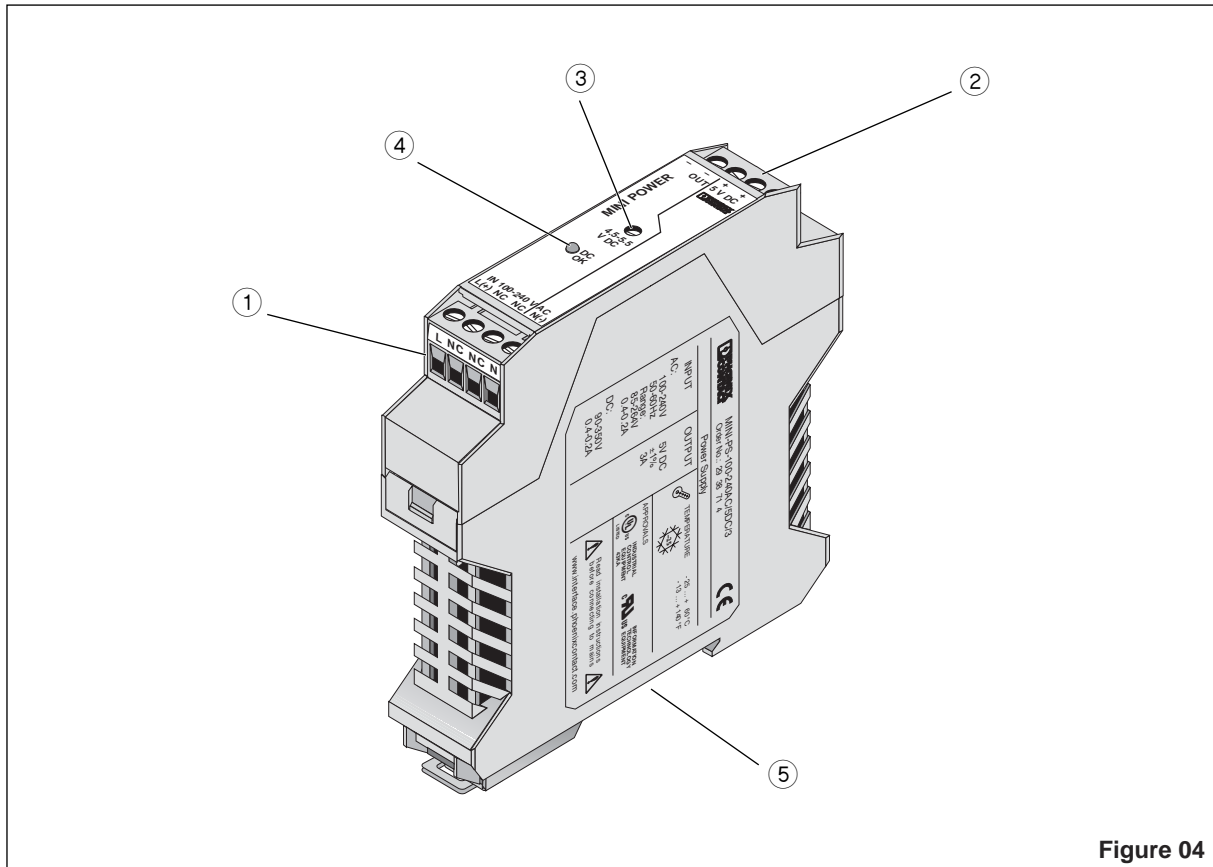

Figure 04

① AC input:

Input voltage 85 - 264 V AC
 Frequency 45 - 65 Hz
 (0.2 mm² to 2.5 mm² solid)
 (0.2 mm² to 2.5 mm² flexible)
 (24 - 14 AWG)
 Internal fuse 2 AT
 Recommended fuse
 10 A or 16 A c.b./Characteristic B

② DC output:

Output voltage 5 V DC (default),
 can be set from 4.5 - 5.5 V DC using
 a potentiometer③ (0.2 mm² to 2.5 mm² solid)
 (0.2 mm² to 2.5 mm² flexible) (AWG 24 - 14)
 The device is idling-proof and short-circuit-proof.

③ Potentiometer 4.5 - 5.5 V DC

④ DC OK LED

⑤ Universal latching foot for EN DIN rails

Installation and startup must only be carried out by qualified personnel. The relevant country-specific regulations (e.g., VDE, DIN) must also be observed.

Before startup it is particularly important to ensure that:

- The line has been connected correctly and protection is provided against electric shock.
- The device can be switched off outside the power supply according to EN 60950 regulations (e.g., by the line protection on the primary side).
- All supply lines have sufficient fuse protection and are the correct size.
- All output cables are the correct size for the maximum device output current or have separate fuse protection.
- Sufficient convection is ensured.

MINI POWER is a built-in device. After installation the terminal area must be covered to provide sufficient protection against unauthorized access to live parts. This is ensured by installing the device in the control cabinet or distributor box.

The device contains dangerous live components and high levels of stored energy.

5. Safety and Warning Instructions

To ensure safe operation of the device and that all functions can be used, please read these instructions carefully.



Caution: Never carry out work when the power is turned on, this is highly dangerous.

6. Installation

6.1. Mounting

The power supply can be snapped onto all DIN rails according to EN 50022-35. The device must be mounted horizontally (input terminals facing downwards).

Installation Dimensions



To ensure sufficient convection, we recommend the following minimum spacing be used between modules:

8.0 cm (3.150 in.) for vertical installation

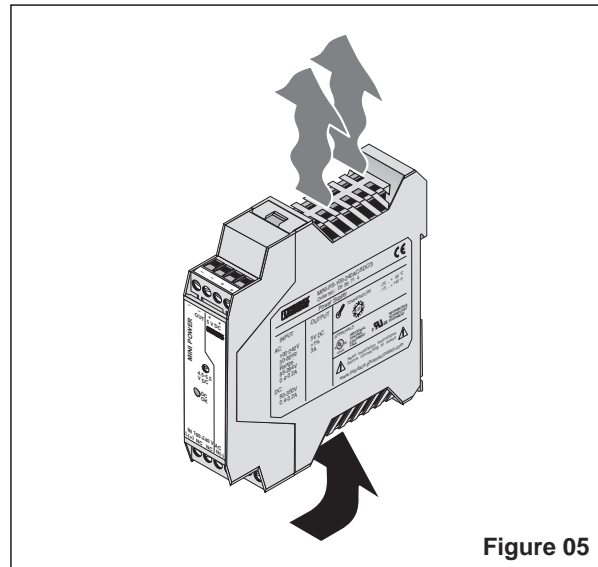

Figure 05

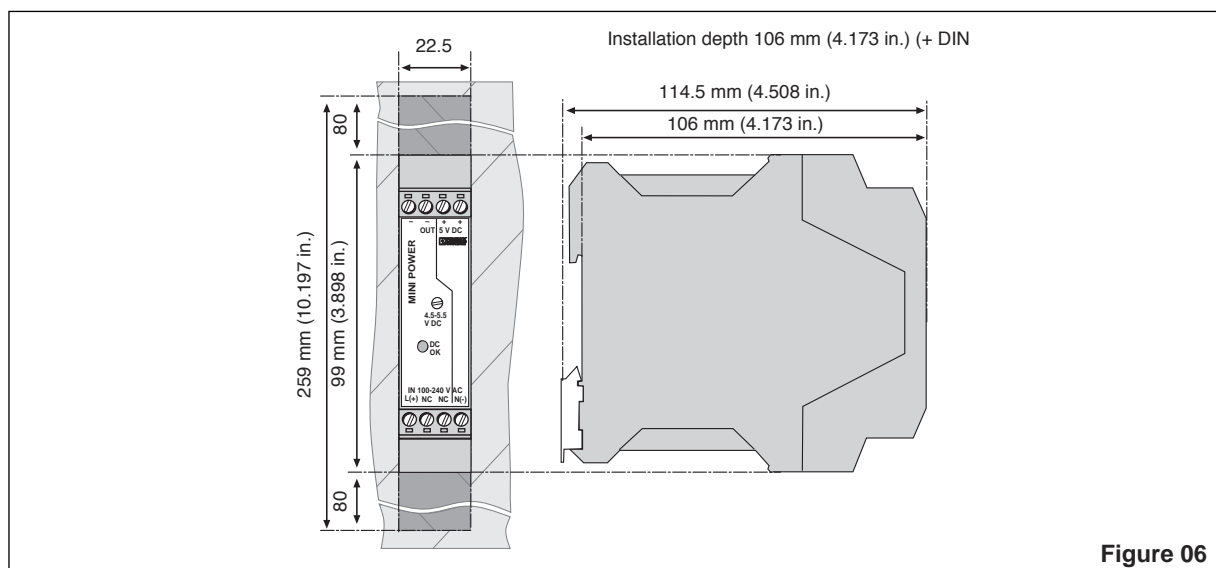

Figure 06

Mounting:

Place the module with the DIN rail guideway on the **top edge** of the DIN rail and then snap it **downwards**.

Removal:

Release the snap-on catch using a screwdriver and then detach the module from the **bottom edge** of the DIN rail.

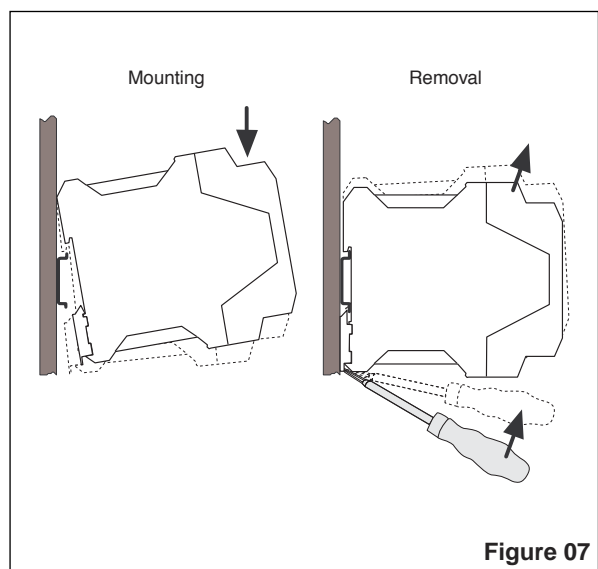

Figure 07

6.2. Connection of Various Types of Network: 100 - 240 V AC Networks

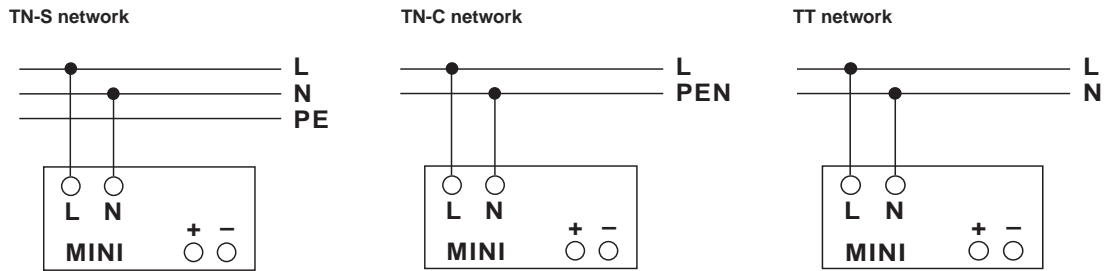

Figure 08

Connection Cable:

The device is equipped with COMBICON connectors. This reliable user-friendly connection method enables quick device connection and safe isolation of the electrical connection, if required. **Only operate connectors when the power is switched off.**

The following cable cross sections can be connected:

	Solid [mm ²]	Flexible [mm ²]	AWG	Torque [Nm]
① Input:	0.2 - 2.5	0.2 - 2.5	24 - 14	0.5 - 0.6
② Output:	0.2 - 2.5	0.2 - 2.5	24 - 14	0.5 - 0.6

For reliable and safe-to-touch connection: Strip 8 mm (0.31 in.) from the connector ends.

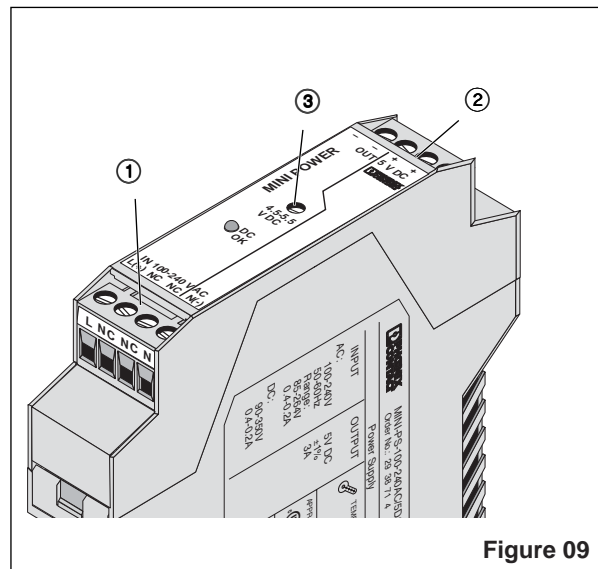
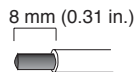

Figure 09

6.3. Input (①, Figure 9)

The 100 - 240 V AC connection is made using screw connections L and N.

Protecting the Primary Side

The device must be installed according to the specifications of EN 60 950. It must be possible to switch off the device using a suitable disconnecting device outside the power supply. For example, primary side line protection could be used.

Additional device protection is not required, as an internal fuse is present.

Recommended Fuse:

Circuit breaker 10 A or 16 A, Characteristic B (or equivalent).

A suitable fuse must be fitted for DC applications.



If the internal fuse is blown, this is most probably due to a device fault. In this case, the device should be checked in the factory.

6.4. Output (②, Figure 9)

The 5 V DC connection is made using the "+" and "-" screw connections on the screw-cage connection ②. The output voltage set upon delivery is 5 V DC.

The output voltage can be adjusted from 4.5 to 5.5 V DC on the potentiometer ③.

Protecting the Secondary Side:

The device is electronic short-circuit-proof and idling-proof. In the event of an error, the output voltage is limited to a maximum of 6 V DC.

It should be ensured that all output cables are the correct size for the maximum output current or have separate fuse protection.

The secondary side cables should have large cross sections to keep voltage drops on the cables to a minimum.

DC OK LED

The green DC OK LED enables local function evaluation in the control cabinet.

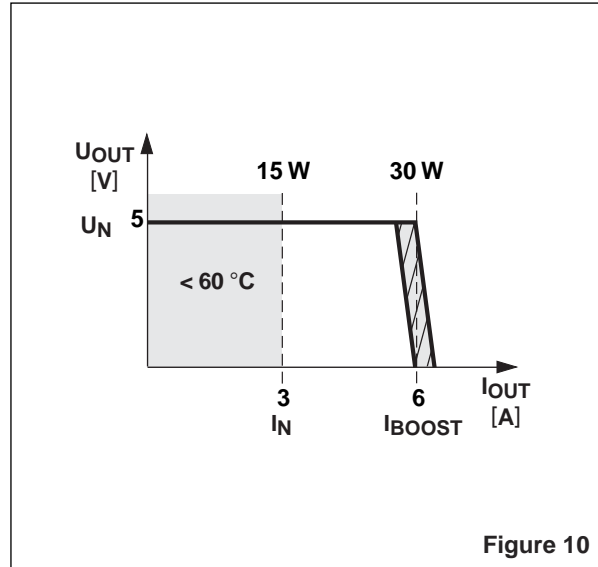

Figure 10

LED on	Normal operation of the power supply
LED off	<p>a) The output voltage is ≤ 4 V DC. There is a secondary load short circuit or overload outside the POWER BOOST area.</p> <p>b) No AC supply voltage is present or there is a device fault.</p>

7. Function

7.1. Output Characteristic Curve

The device can supply up to 6 A at 5 V DC output voltage for a few minutes ($P_{out} = 30$ W).

With high loads, the working point demonstrates the U/I characteristic curve shown in Figure 10. The output current is limited to I_{BOOST} . The secondary voltage is reduced until the short circuit on the secondary side is removed.

The U/I characteristic curve ensures that both heavy capacitive loads and devices with DC/DC converters can be supplied by MINI POWER in the input circuit without any problems.

Connected fuses are reliably tripped. The selectivity in your system configuration is ensured at all times.

7.2. Temperature Response

At an ambient temperature of up to +60°C (+140°F) the device can supply an nominal current of 3 A. POWER BOOST is available for a few minutes. The output power must be decreased by 5% per Kelvin temperature increase for ambient temperatures over +60°C (+140°F).

At ambient temperatures over +70°C (+158°F) or in the event of a thermal overload, the device switches off to protect itself. The device switches on again once it has cooled down.

7.3. Parallel Operation

Devices of the same type can be connected in parallel to increase both redundancy and power. The default setting does not have to be adjusted.

If the output voltage is adjusted, an even current distribution can be ensured by precisely setting all power supplies that are operated in parallel to the same output voltage.

To ensure symmetrical current distribution we recommend that all cable connections from the power supply to the DIN rail are the same length and have the same cross section.

Depending on the system, for parallel connection of more than two power supplies a protective circuit should be installed at each individual device output (e.g., decoupling diode or DC fuse). This means that in the event of a secondary device fault high return currents are avoided.

7.4. Redundancy Operation

Redundant connections are designed for supplying systems, which place particularly high requirements on operational safety. If a fault occurs in the primary circuit of device no. 1, device no. 2 automatically takes over the complete power supply without interruption and vice versa.

For this purpose, the power supplies to be connected in parallel must be large enough that the total current requirements of all loads can be completely covered by one power supply. External decoupling diodes or are required for 100% redundancy.

7.5. Power Increase

The output current can be increased to $n \times I_N$ where n is the number of devices connected in parallel.

The parallel connection for power increase can be used to extend existing systems. A parallel connection is recommended if the power supply does not cover the current consumption of the most powerful load. Otherwise, the loads should be divided over independent individual devices.

A maximum of five devices can be connected in parallel.

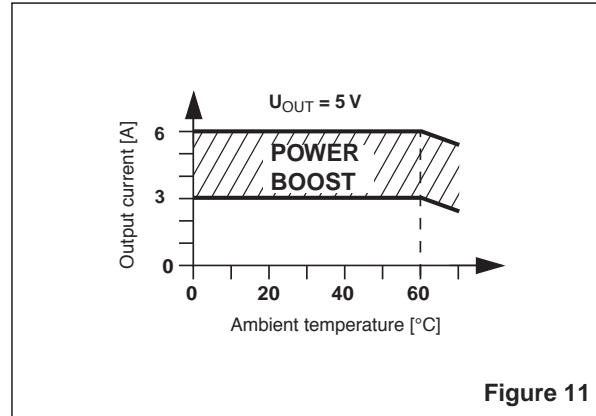

Figure 11

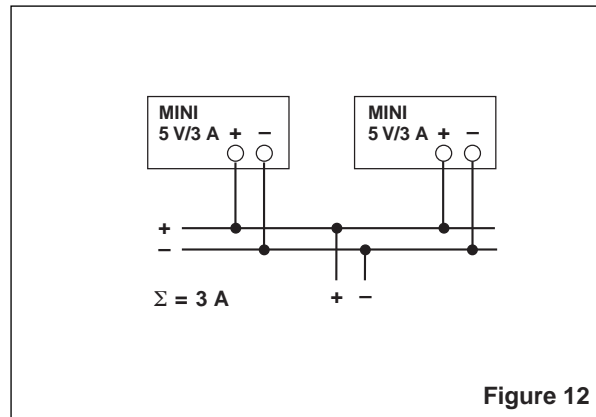

Figure 12

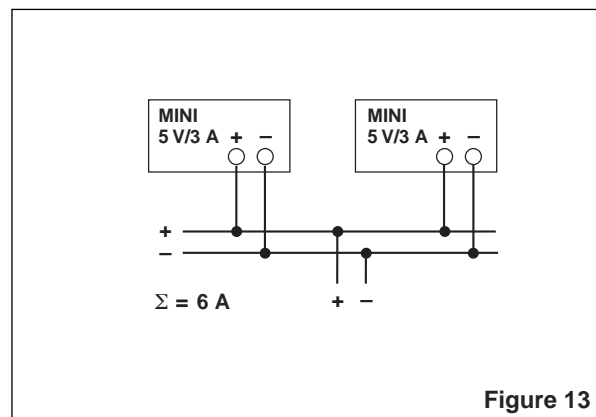

Figure 13



Стандарт Электрон Связь

Мы молодая и активно развивающаяся компания в области поставок электронных компонентов. Мы поставляем электронные компоненты отечественного и импортного производства напрямую от производителей и с крупнейших складов мира.

Благодаря сотрудничеству с мировыми поставщиками мы осуществляем комплексные и плановые поставки широчайшего спектра электронных компонентов.

Собственная эффективная логистика и склад в обеспечивает надежную поставку продукции в точно указанные сроки по всей России.

Мы осуществляем техническую поддержку нашим клиентам и предпродажную проверку качества продукции. На все поставляемые продукты мы предоставляем гарантию .

Осуществляем поставки продукции под контролем ВП МО РФ на предприятия военно-промышленного комплекса России , а также работаем в рамках 275 ФЗ с открытием отдельных счетов в уполномоченном банке. Система менеджмента качества компании соответствует требованиям ГОСТ ISO 9001.

Минимальные сроки поставки, гибкие цены, неограниченный ассортимент и индивидуальный подход к клиентам являются основой для выстраивания долгосрочного и эффективного сотрудничества с предприятиями радиоэлектронной промышленности, предприятиями ВПК и научно-исследовательскими институтами России.

С нами вы становитесь еще успешнее!

Наши контакты:

Телефон: +7 812 627 14 35

Электронная почта: sales@st-electron.ru

Адрес: 198099, Санкт-Петербург,
Промышленная ул, дом № 19, литера Н,
помещение 100-Н Офис 331