

Infrared Remote Control System-on-Chip

General Description

The MAXQ617 is a low-power, 16-bit MAXQ® microcontroller designed for low-power applications including universal remote controls, consumer electronics, and white goods. The device combines a powerful 16-bit RISC microcontroller and integrated peripherals including a universal synchronous/asynchronous receiver-transmitter (USART), an SPI master/slave and two I²C communications ports, along with an IR module with carrier frequency generation and flexible port I/O capable of multiplexed keypad control. An internal amplifier eliminates the need for external circuitry to drive the IR receiver pin.

The device includes 80KB of flash memory and 4KB of data SRAM.

For the ultimate in low-power battery-operated performance, the device includes an ultra-low-power stop mode (0.2µA typ). In this mode, the minimum amount of circuitry is powered. Wake-up sources include external interrupts, the power-fail interrupt, and a timer interrupt. The microcontroller runs from a wide 1.67V to 3.6V operating voltage.

Applications

Universal Remote Controls for Tablets

Universal Remote Controls for Smartphones

Block Diagram

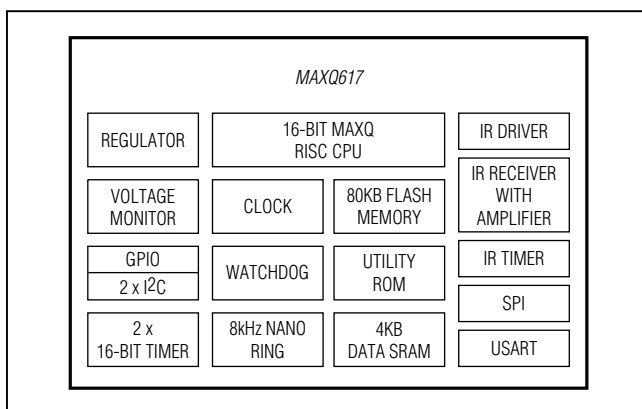

MAXQ is a registered trademark of Maxim Integrated Products, Inc.

Features

- ◆ High-Performance, Low-Power, 16-Bit RISC Core
- ◆ Internal 12MHz Oscillator Requires no External Components
- ◆ 1.67V to 3.6V Operating Voltage
- ◆ 33 Total Instructions for Simplified Programming
- ◆ Three Independent Data Pointers Accelerate Data Movement with Automatic Increment/Decrement
- ◆ Dedicated Pointer for Direct Read from Code Space
- ◆ 16-Bit Instruction Word, 16-Bit Data Bus
- ◆ 16 x 16-Bit General-Purpose Working Registers
- ◆ Memory Features
 - ◇ 80KB Flash Memory
 - ◇ 4KB Data SRAM
- ◆ Additional Peripherals
 - ◇ Power-Fail Warning
 - ◇ Power-On Reset (POR)/Brownout Reset
 - ◇ Automatic IR Carrier Frequency Generation and Modulation
 - ◇ IR Learning Amplifier
 - ◇ IR Transmit Driver with 200mA (min) Sink Current at 1.8V
 - ◇ Two 16-Bit Programmable Timers/Counters with Prescaler and Capture/Compare
 - ◇ One SPI, Two I²C, and One USART Port
 - ◇ Programmable Watchdog Timer
 - ◇ 8kHz Nanopower Ring Oscillator Wake-Up Timer
 - ◇ Up to 10 General-Purpose I/Os
- ◆ Low Power Consumption
 - ◇ 0.2µA (typ), 2.0µA (max) in Stop Mode, T_A = +25°C, Power-Fail Monitor Disabled
 - ◇ 2.0mA (typ) at 12MHz in Active Mode

[Ordering Information](#) appears at end of data sheet.

Infrared Remote Control System-on-Chip

TABLE OF CONTENTS

General Description	1
Applications	1
Features	1
Block Diagram	1
Absolute Maximum Ratings	4
Package Thermal Characteristics	4
Electrical Characteristics	4
Ball Configuration	7
Ball Description	7
Detailed Description	9
Microprocessor	9
Memory	9
Stack Memory	9
Utility ROM	10
Watchdog Timer	10
IR Carrier Generation and Modulation Timer	10
Carrier Generation Module	11
IR Transmission	11
IR Receive	13
Carrier Burst-Count Mode	14
16-Bit Timers/Counters	14
Serial Peripherals	15
Serial Peripheral Interface (SPI)	15
I ² C Bus	16
USART	16
General-Purpose I/O	16
On-Chip Oscillator	16
Operating Modes	16
Power-Fail Detection	17
Applications Information	21
Grounds and Bypassing	21
Ordering Information/Selector Guide	22
Package Information	22
Additional Documentation	22
Development and Technical Support	22

Infrared Remote Control System-on-Chip

TABLE OF CONTENTS (continued)

Appendix A.	23
I ² C Serial peripheral specifications	23
I ² C Serial Diagrams	25
SPI Electrical Characteristics	26
SPI Timing Diagrams	27
USART Timing	28
Revision History	29

LIST OF FIGURES

Figure 1. IR Transmit Frequency Shifting Example (IRCFME = 0)	12
Figure 2. IR Transmit Carrier Generation and Carrier Modulator Control.	12
Figure 3. IR Transmission Waveform (IRCFME = 0).	13
Figure 4. IR Capture.	14
Figure 5. Receive Burst-Count Example	15
Figure 6. Power-Fail Detection During Normal Operation	17
Figure 7. Stop Mode Power-Fail Detection States with Power-Fail Monitor Enabled	19
Figure 8. Stop Mode Power-Fail Detection with Power-Fail Monitor Disabled	20
Figure 9. Series Resistors (R _S) for Protecting Against High-Voltage Spikes	25
Figure 10. I ² C Bus Controller Timing Diagram.	25
Figure 11. SPI Master Communication Timing	27
Figure 12. SPI Slave Communication Timing	27
Figure 13. USART Timing Diagram	28

LIST OF TABLES

Table 1. Watchdog Interrupt Timeout (Sysclk = 12MHz, CD[1:0] = 00).	10
Table 2. USART Mode Details	16
Table 3. Power-Fail Warning Voltage Selection	17
Table 4. Power-Fail Detection States During Normal Operation	18
Table 5. Stop Mode Power-Fail Detection States with Power-Fail Monitor Enabled	19
Table 6. Stop Mode Power-Fail Detection States with Power-Fail Monitor Disabled	20

Infrared Remote Control System-on-Chip

ABSOLUTE MAXIMUM RATINGS

(All voltages with respect to GND.)

Voltage Range on V_{DD}-0.3V to +3.6V
 Voltage Range on Any Lead Except V_{DD} .. -0.3V to ($V_{DD} + 0.5V$)
 Continuous Power Dissipation ($T_A = +70^\circ\text{C}$)
 WLP (multilayer board)
 (derate 17.20mW/ $^\circ\text{C}$ above $+70^\circ\text{C}$).....1600mW

Operating Temperature Range.....-20 $^\circ\text{C}$ to +70 $^\circ\text{C}$
 Storage Temperature Range.....-65 $^\circ\text{C}$ to +150 $^\circ\text{C}$
 Soldering Temperature (reflow)+260 $^\circ\text{C}$
 Continuous Output Current
 Any Single I/O Pin.....32mA
 All I/O Pins Combined.....32mA

Stresses beyond those listed under "Absolute Maximum Ratings" may cause permanent damage to the device. These are stress ratings only, and functional operation of the device at these or any other conditions beyond those indicated in the operational sections of the specifications is not implied. Exposure to absolute maximum rating conditions for extended periods may affect device reliability.

PACKAGE THERMAL CHARACTERISTICS

WLP

Junction-to-Ambient Thermal Resistance (θ_{JA})58 $^\circ\text{C}/\text{W}$

Package thermal resistances were obtained using the method described in JEDEC specification JESD51-7, using a four-layer board. For detailed information on package thermal considerations, refer to www.maxim-ic.com/thermal-tutorial.

ELECTRICAL CHARACTERISTICS

(Limits are 100% tested at $T_A = +25^\circ\text{C}$ and $T_A = +85^\circ\text{C}$. Limits over the operating temperature range and relevant supply voltage range are guaranteed by design and characterization. Specifications marked GBD are guaranteed by design and not production tested.)

PARAMETER	SYMBOL	CONDITIONS	MIN	TYP	MAX	UNITS
Supply Voltage	V_{DD}		V_{RST}		3.6	V
1.8V Internal Regulator	V_{REG18}		1.59	1.8	1.98	V
Power-Fail Warning Voltage	V_{PFW}	PFWARNCN[1:0] = 00 (default)	1.64	1.67	1.70	V
		GBD, all other values of PFWARNCN[1:0] as shown in Table 3	-3%		+3%	
Power-Fail Reset Voltage	V_{RST}		1.61		1.67	V
Power-Fail Warning/Reset Offset	$V_{PFWOFFSET}$	PFWARNCN[1:0] = 00, $V_{PFW} > V_{RST}$		30		mV
Power-On Reset Voltage	V_{POR}	Monitors V_{DD}		1.2		V
RAM Data Retention Voltage	V_{DRV}			1.0		V
Active Current	I_{DD_1}	$f_{SYSCLK} = 12\text{MHz}$, executing code from flash memory, all inputs connected to GND/ V_{DD} , outputs do not source or sink current		2	3.5	mA
Stop Mode Current	I_{S1}	$T_A = +25^\circ\text{C}$ (power-fail off)		0.15	2.0	μA
		$T_A = 0^\circ\text{C}$ to $+70^\circ\text{C}$ (power-fail off)		0.15	8	
	I_{S2}	$T_A = +25^\circ\text{C}$ (power-fail on)		22	31	
		$T_A = 0^\circ\text{C}$ to $+70^\circ\text{C}$ (power-fail on)		27.6	38	
Power Consumption During Power-On Reset	I_{POR}	During POR while $V_{DD} < V_{POR}$		100		nA

Infrared Remote Control System-on-Chip

ELECTRICAL CHARACTERISTICS (continued)

(Limits are 100% tested at $T_A = +25^\circ\text{C}$ and $T_A = +85^\circ\text{C}$. Limits over the operating temperature range and relevant supply voltage range are guaranteed by design and characterization. Specifications marked GBD are guaranteed by design and not production tested.)

PARAMETER	SYMBOL	CONDITIONS	MIN	TYP	MAX	UNITS
Stop Mode Resume Time	t_{ON}		375 + (8192 t_{CK})			μs
Input Low Voltage for IRRX and All Port Pins	V_{IL}		V_{GND}		0.3 V_{DD}	V
Input High Voltage for IRRX and All Port Pins	V_{IH}		0.7 V_{DD}		V_{DD}	V
Input Hysteresis (Schmitt)	V_{IHYS}	$V_{DD} = 3.3\text{V}$, $T_A = +25^\circ\text{C}$	300			mV
IRRX Input Filter Pulse-Width Reject	t_{IRRX_R}		50			ns
IRRX Input Filter Pulse-Width Accept	t_{IRRX_A}		300			ns
IRTX Sink Current	I_{IRTX}	$V_{IRTX} \geq 0.25\text{V}$	200			mA
Output Low Voltage for All Port Pins	V_{OL}	$V_{DD} = 3.6\text{V}$, $I_{OL} = 11\text{mA}$	0.4		0.5	V
		$V_{DD} = 2.35\text{V}$, $I_{OL} = 8\text{mA}$	0.4		0.5	
		$V_{DD} = 1.8\text{V}$, $I_{OL} = 4.5\text{mA}$	0.4		0.5	
Output High Voltage All Port Pins	V_{OH}	$I_{OH} = -2\text{mA}$	$V_{DD} - 0.5$		V_{DD}	V
Input/Output Pin Capacitance for All Port Pins	C_{IO}		15			pF
Input Leakage Current for All Pins	I_L	Internal pullup disabled	-100		+100	nA
Input Pullup Resistor for $\overline{\text{RESET}}$, IRRX, and All Port Pins	R_{PU}	$V_{DD} = 3.0\text{V}$, $V_{OL} = 0.4\text{V}$	16	28	39	k Ω
		$V_{DD} = 1.8\text{V}$, $V_{OL} = 0.4\text{V}$	18	31	43	k Ω
LEARNING AMPLIFIER						
IRRX Amplifier Input Low Detection	I_{DL}	$V_{DD} = 1.8\text{V}$, $I_{RRCVEN} = 1$	0.2			μA
IRRX Amplifier Input High Detection	I_{DH}	$V_{DD} = 1.8\text{V}$, $I_{RRCVEN} = 1$	1.25			μA
CLOCK						
Internal Oscillator Frequency	f_{OSC}		12			MHz
Internal Oscillator Variability	f_{OSC_VAR}	$T_A = -20^\circ\text{C}$ to $+70^\circ\text{C}$	$\pm 1\%$			MHz
		$T_A = +25^\circ\text{C}$, $V_{DD} = 1.8\text{V}$	$\pm 0.5\%$			
		$T_A = +15^\circ\text{C}$ to $+40^\circ\text{C}$, $V_{DD} = 1.8\text{V} \pm 5\%$	$\pm 0.5\%$			

Infrared Remote Control System-on-Chip

ELECTRICAL CHARACTERISTICS (continued)

(Limits are 100% tested at $T_A = +25^\circ\text{C}$ and $T_A = +85^\circ\text{C}$. Limits over the operating temperature range and relevant supply voltage range are guaranteed by design and characterization. Specifications marked GBD are guaranteed by design and not production tested.)

PARAMETER	SYMBOL	CONDITIONS	MIN	TYP	MAX	UNITS
System Clock Period	t_{CK}			$1/f_{OSC}$		ns
System Clock Frequency	f_{CK}			$1/t_{CK}$		MHz
NANOPOWER RING						
Nanopower Ring Frequency	f_{NANO}	$T_A = +25^\circ\text{C}$	3.0	8.0	20.0	kHz
		$T_A = +25^\circ\text{C}, V_{DD} = \text{POR voltage}$	1.7	2.4		
WAKE-UP TIMER						
Wakeup Timer Interval	t_{WAKEUP}		$1/f_{NANO}$		65,535/ f_{NANO}	s
FLASH MEMORY						
System Clock During Flash Programming/Erase	$f_{FPSYSCLK}$	$f_{FPSYSCLK}/(FCKDIV[3:0]+1)$ must equal 1MHz, verify PFI = 0 before calling utility ROM.		f_{OSC}		MHz
Flash Erase Time	t_{ME}	Mass erase		40		ms
	t_{ERASE}	Page erase		40		ms
Flash Programming Time per Word	t_{PROG}	Excluding utility ROM overhead		40		μs
Write/Erase Cycles			20,000			Cycles
Data Retention		$T_A = +25^\circ\text{C}$	100			Years

MAXQ617

Infrared Remote Control System-on-Chip

Ball Configuration

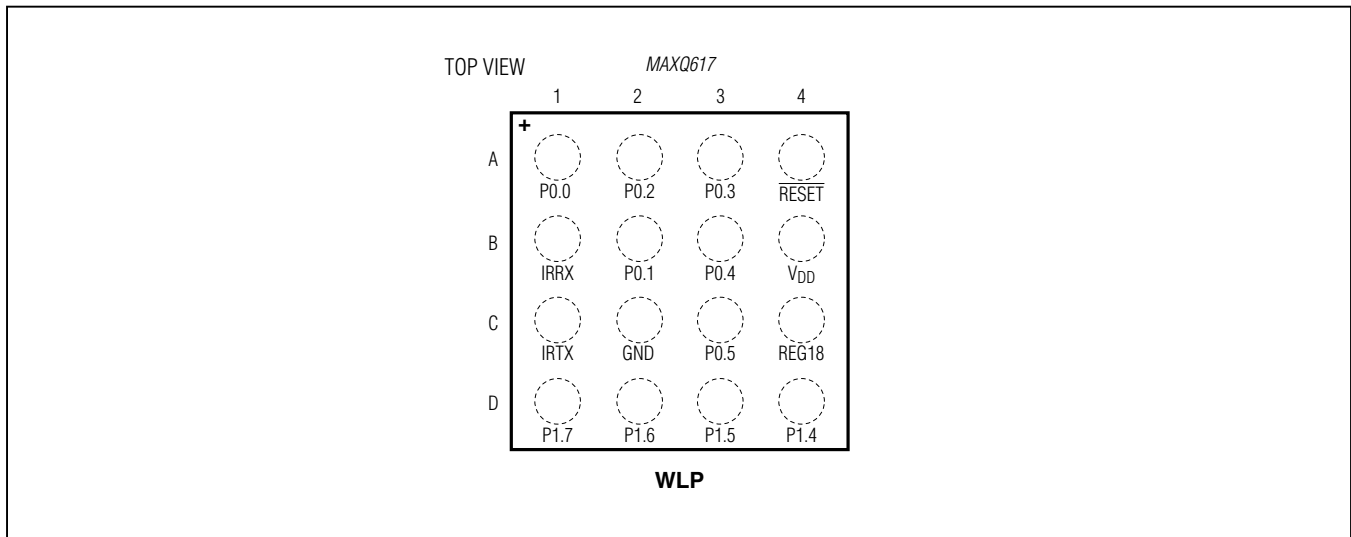

Ball Description

BALL	NAME	FUNCTION
POWER BALLS		
B4	V _{DD}	Supply Voltage
C2	GND	Ground. Connect directly to the ground plane.
C4	REG18	1.8V Regulator Output. This pin must be connected to ground through a 1.0μF external ceramic-chip capacitor. The capacitor must be placed as close to this pin as possible. No devices other than the capacitor should be connected to this pin.
RESET BALLS		
A4	RESET	Digital, Active-Low Reset Input/Output. The device remains in reset as long as this pin is low and begins executing from the utility ROM at address 8000h when this pin returns to a high state. The pin includes pullup current source; if this pin is driven by an external device, it should be driven by an open-drain source capable of sinking in excess of 4mA. This pin can be left unconnected if there is no need to place the device in a reset state using an external signal. This pin is driven low as an output when an internal reset condition occurs.
IR FUNCTION BALLS		
C1	IRTX	IR Transmit Output. This pin defaults to a high-impedance input with the weak pullup disabled during all forms of reset. Software must configure this pin after release from reset to remove the high-impedance input condition.
B1	IRRX	IR Receive Input. This pin defaults to a high-impedance input with the weak pullup disabled during all forms of reset. Software must configure this pin after release from reset to remove the high-impedance input condition and to enable the IR amplifier if desired.

Infrared Remote Control System-on-Chip

Ball Description (continued)

BALL	NAME	FUNCTION	
GENERAL-PURPOSE I/O AND SPECIAL FUNCTION BALLS			
		Port 0 General-Purpose, Digital I/O Pins. These port pins function as general-purpose I/O pins with their input and output states controlled by the PD0, PO0, and PI0 registers. All port pins default to high-impedance mode after a reset. Software must configure these pins after release from reset to remove the high-impedance condition. All special functions must be enabled from software before they can be used.	
		GPIO PORT PIN	SPECIAL FUNCTION
A1	P0.0 RX0 MOSI INT0	P0.0	RX0: USART receive MOSI: SPI master out slave in INT0: External interrupt 0
B2	P0.1 TX0 MISO INT1	P0.1	TX0: USART transmit MISO: SPI master in slave out INT1: External interrupt 1
A2	P0.2 SCL0 SCLK INT2	P0.2	SCL0: I ² C clock SCLK: SPI clock INT2: External interrupt 2
A3	P0.3 SDA0 SSEL INT3	P0.3	SDA0: I ² C data SSEL: SPI slave select INT3: External interrupt 3
B3	P0.4 TBA0 INT4	P0.4	TBA0: Timer B A0 INT4: External interrupt 4
C3	P0.5 TBB0 INT5	P0.5	TBB0: Timer B B0 INT5: External interrupt 5
		Port 1 General-Purpose, Digital I/O Pins. These port pins function as general-purpose I/O pins with their input and output states controlled by the PD1, PO1, and PI1 registers. The JTAG pins default to their JTAG function with weak pullups enabled after a reset. The JTAG function can be disabled using the TAP bit in the SC register.	
		GPIO PORT PIN	SPECIAL FUNCTION
D4	P1.4/TCK/SCL1	P1.4	SCL1: I ² C clock, TCK: JTAG test clock
D3	P1.5/TDI/SDA1	P1.5	SDA1: I ² C data, TDI: JTAG data input
D2	P1.6/TMS	P1.6	TMS: JTAG test mode select
D1	P1.7/TDO	P1.7	TDO: JTAG Data Output. TDO functions as the test-data output on reset and defaults to an input with a weak pullup. The output function of the test data is only enabled during the TAP's Shift_IR or Shift_DR states.

Infrared Remote Control System-on-Chip

Detailed Description

The MAXQ617 provides integrated, low-cost solutions that simplify the design of IR communications equipment such as universal remote controls. Standard features include the highly optimized, single-cycle, MAXQ, 16-bit RISC core; 80KB flash memory; 4KB data RAM; soft stack; 16 general-purpose registers; and three data pointers. The MAXQ core has the industry's best MIPS/mA rating, allowing developers to achieve the same performance as competing microcontrollers at substantially lower clock rates. Lower active-mode current combined with the even lower stop-mode current (0.2 μ A typ) results in increased battery life. Application-specific peripherals include flexible timers for generating IR carrier frequencies and modulation. A high-current IR drive pin operates with an internal receiver amplifier without external components. It also includes general-purpose I/O pins ideal for keypad matrix input, and a power-fail-detection circuit to notify the application when the supply voltage is nearing the microcontroller's minimum operating voltage.

The internal 12MHz oscillator requires no external components and executes instructions. Operating from DC to 12MHz, almost all instructions execute in a single clock cycle (83.3ns at 12MHz), enabling nearly 12MIPS true-code operation. When active device operation is not required, an ultra-low-power stop mode can be invoked from software, resulting in quiescent current consumption of less than 0.2 μ A (typ) and 2.0 μ A (max). The combination of high-performance instructions and ultra-low stop-mode current increases battery life over competing microcontrollers. An integrated POR circuit with brownout support resets the device to a known condition following a power-up cycle or brownout condition. Additionally, a power-fail warning flag is set, and a power-fail interrupt can be generated when the system voltage falls below the power-fail warning voltage, V_{PFW} . The configurable power-fail warning feature allows the application to notify the user that the system supply is low and appropriate action should be taken.

Microprocessor

The device is based on Maxim Integrated's low-power, 16-bit MAXQ20S. The core supports the Harvard memory architecture with separate 16-bit program and data address buses. A fixed 16-bit instruction word is standard, but data can be arranged in 8 or 16 bits. The MAXQ core in the device is implemented as a pipe-

lined processor with performance approaching 1MIPS per MHz. The 16-bit data path is implemented around register modules, and each register module contributes specific functions to the core. The accumulator module consists of sixteen 16-bit registers and is tightly coupled with the arithmetic logic unit (ALU). A configurable soft stack supports program flow.

Execution of instructions is triggered by data transfer between functional register modules or between a functional register module and memory. Because data movement involves only source and destination modules, circuit switching activities are limited to active modules only. For power-conscious applications, this approach localizes power dissipation and minimizes switching noise. The modular architecture also provides a maximum of flexibility and reusability that are important for a microprocessor used in embedded applications.

The MAXQ instruction set is highly orthogonal. All arithmetical and logical operations can use any register in conjunction with the accumulator. Data movement is supported from any register to any other register. Memory is accessed through specific data-pointer registers with autoincrement/decrement support.

Memory

The microcontroller incorporates several memory types:

- 80KB flash memory
- 4KB SRAM data memory
- Dedicated utility ROM
- Soft stack

Stack Memory

The device provides a soft stack that can be used to store program return addresses (for subroutine calls and interrupt handling) and other general-purpose data. This soft stack is located in the SRAM data memory, which means that the SRAM data memory must be shared between the soft stack and general-purpose application data storage. However, the location and size of the soft stack is determined by the user, providing maximum flexibility when allocating resources for a particular application. The stack is used automatically by the processor when the CALL, RET, and RETI instructions are executed and when an interrupt is serviced. An application can also store and retrieve values explicitly using the stack by means of the PUSH, POP, and POPI instructions.

Infrared Remote Control System-on-Chip

The SP pointer indicates the current top of the stack, which initializes by default to the top of the SRAM data memory. As values are pushed onto the stack, the SP pointer decrements, which means that the stack grows downward towards the bottom (lowest address) of the data memory. Popping values off the stack causes the SP pointer value to increase. Refer to the *User's Guide* for more details.

Utility ROM

The utility ROM is located in program space beginning at address 8000h. This ROM includes the following routines:

- Production test routines (internal memory tests, memory loader, etc.), which are used for internal testing only, and are generally of no use to the end-application developer
- User-callable routines for buffer copying and fast table lookup (more information on these routines can be found in the *User's Guide*)

Following any reset, execution begins in the utility ROM at address 8000h. At this point, unless test mode has been invoked (which requires special programming through the JTAG interface), the utility ROM in the device always automatically jumps to location 0000h, which is the beginning of user application code.

Watchdog Timer

The internal watchdog timer greatly increases system reliability. The timer resets the device if software execution is disturbed. The watchdog timer is a free-running counter designed to be periodically reset by the application software. If software is operating correctly, the counter is

periodically reset and never reaches its maximum count. However, if software operation is interrupted, the timer does not reset, triggering a system reset and optionally a watchdog timer interrupt. This protects the system against electrical noise or electrostatic discharge (ESD) upsets that could cause uncontrolled processor operation. The internal watchdog timer is an upgrade to older designs with external watchdog devices, reducing system cost and simultaneously increasing reliability.

The watchdog timer functions as the source of both the watchdog timer timeout and the watchdog timer reset. The timeout period can be programmed in a range of 2^{15} to 2^{24} system clock cycles. An interrupt is generated when the timeout period expires if the interrupt is enabled. All watchdog timer resets follow the programmed interrupt timeouts by 512 system clock cycles. If the watchdog timer is not restarted for another full interval in this time period, a system reset occurs when the reset timeout expires. See [Table 1](#).

IR Carrier Generation and Modulation Timer

The dedicated IR timer/counter module simplifies low-speed infrared (IR) communication. The IR timer implements two pins (IRTX and IRRX) for supporting IR transmit and receive, respectively. The IRTX pin has no corresponding port pin designation, so the standard PD, PO, and PI port control status bits are not present. However, the IRTX pin output can be manipulated high or low using the PWCN.IRTXOUT and PWCN.IRTXOE bits when the IR timer is not enabled (i.e., IREN = 0).

Table 1. Watchdog Interrupt Timeout (Sysclk = 12MHz, CD[1:0] = 00)

WD[1:0]	WATCHDOG CLOCK	WATCHDOG INTERRUPT TIMEOUT	WATCHDOG RESET AFTER WATCHDOG INTERRUPT (μs)
00	$\text{Sysclk}/2^{15}$	2.7ms	42.7
01	$\text{Sysclk}/2^{18}$	21.9ms	42.7
10	$\text{Sysclk}/2^{21}$	174.7ms	42.7
11	$\text{Sysclk}/2^{24}$	1.4s	42.7

Infrared Remote Control System-on-Chip

The IR timer is composed of a carrier generator and a carrier modulator. The carrier generation module uses the 16-bit IR carrier register (IRCA) to define the high and low time of the carrier through the IR carrier high byte (IRCAH) and IR carrier low byte (IRCAL). The carrier modulator uses the IR data bit (IRDATA) and IR modulator time register (IRMT) to determine whether the carrier or the idle condition is present on IRTX.

The IR timer is enabled when the IR enable bit (IREN) is set to 1. The IR Value register (IRV) defines the beginning value for the carrier modulator. During transmission, the IRV register is initially loaded with the IRMT value and begins down counting towards 0000h, whereas in receive mode it counts upward from the initial IRV register value. During the receive operation, the IRV register can be configured to reload with 0000h when capture occurs on detection of selected edges or can be allowed to continue free-running throughout the receive operation. An overflow occurs when the IR timer value rolls over from 0FFFFh to 0000h. The IR overflow flag (IROV) is set to 1 and an interrupt is generated if enabled (IRIE = 1).

Carrier Generation Module

The IRCAH byte defines the carrier high time in terms of the number of IR input clocks, whereas the IRCAL byte defines the carrier low time.

- IR Input Clock (f_{IRCLK}) = $f_{SYS}/2^{IRDIV[2:0]}$
- Carrier Frequency ($f_{CARRIER}$) = $f_{IRCLK}/(IRCAH + IRCAL + 2)$
- Carrier High Time = $IRCAH + 1$
- Carrier Low Time = $IRCAL + 1$
- Carrier Duty Cycle = $(IRCAH + 1)/(IRCAH + IRCAL + 2)$

During transmission, the IRCA register is latched for each IRV down-count interval, and is sampled along with the IRTXPOL and IRDATA bits at the beginning of each new IRV down-count interval so that duty-cycle variation and frequency shifting is possible from one interval to the next, which is illustrated in [Figure 1](#).

[Figure 2](#) illustrates the basic carrier generation and its path to the IRTX output pin. The IR transmit polarity bit (IRTXPOL) defines the starting/idle state and the carrier polarity of the IRTX pin when the IR timer is enabled.

IR Transmission

During IR transmission (IRMODE = 1), the carrier generator creates the appropriate carrier waveform, while the carrier modulator performs the modulation. The carrier modulation can be performed as a function of carrier cycles or IRCLK cycles dependent on the setting of the IRCFME bit. When IRCFME = 0, the IRV down counter is clocked by the carrier frequency and thus the modulation is a function of carrier cycles ([Figure 3](#)). When IRCFME = 1, the IRV down counter is clocked by IRCLK, allowing carrier modulation timing with IRCLK resolution.

The IRTXPOL bit defines the starting/idle state as well as the carrier polarity for the IRTX pin. If IRTXPOL = 1, the IRTX pin is set to a logic-high when the IR timer module is enabled. If IRTXPOL = 0, the IRTX pin is set to a logic-low when the IR timer is enabled.

A separate register bit, IR data (IRDATA), is used to determine whether the carrier generator output is output to the IRTX pin for the next IRMT carrier cycles. When IRDATA = 1, the carrier waveform (or inversion of this waveform if IRTXPOL = 1) is output on the IRTX pin during the next IRMT cycles. When IRDATA = 0, the idle condition, as defined by IRTXPOL, is output on the IRTX pin during the next IRMT cycles.

The IR timer acts as a down counter in transmit mode. An IR transmission starts when the IREN bit is set to 1 when IRMODE = 1; when the IRMODE bit is set to 1 when IREN = 1; or when IREN and IRMODE are both set to 1 in the same instruction. The IRMT and IRCA registers, along with the IRDATA and IRTXPOL bits, are sampled at the beginning of the transmit process and every time the IR timer value reloads its value. When the IRV reaches 0000h value, on the next carrier clock, it does the following:

- 1) Reloads IRV with IRMT.
- 2) Samples IRCA, IRDATA, and IRTXPOL.
- 3) Generates IRTX accordingly.
- 4) Sets IRIF to 1.
- 5) Generates an interrupt to the CPU if enabled (IRIE = 1).

To terminate the current transmission, the user can switch to receive mode (IRMODE = 0) or clear IREN to 0.

Carrier Modulation Time = IRMT + 1 carrier cycles

Infrared Remote Control System-on-Chip

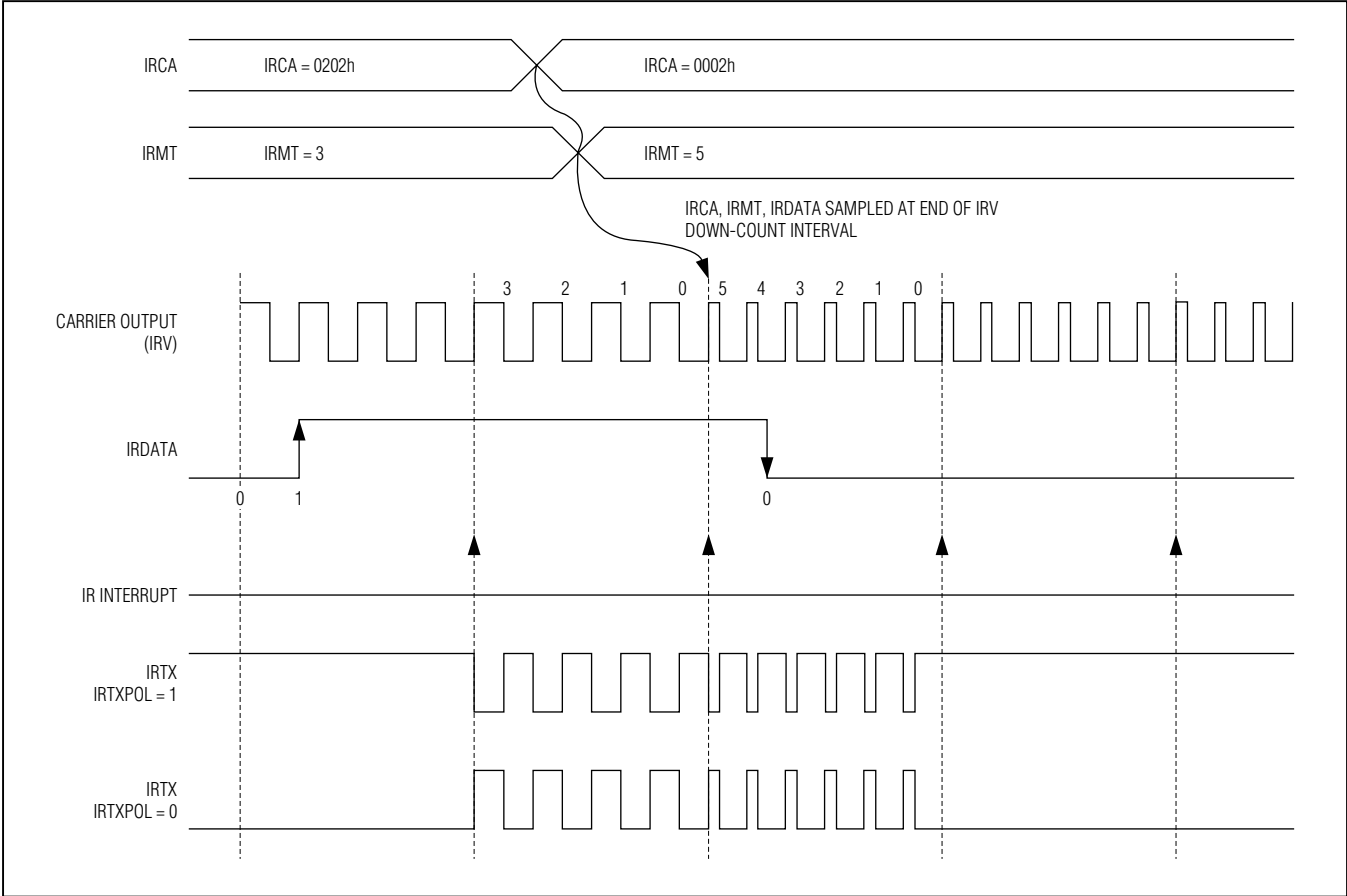

Figure 1. IR Transmit Frequency Shifting Example (IRCFME = 0)

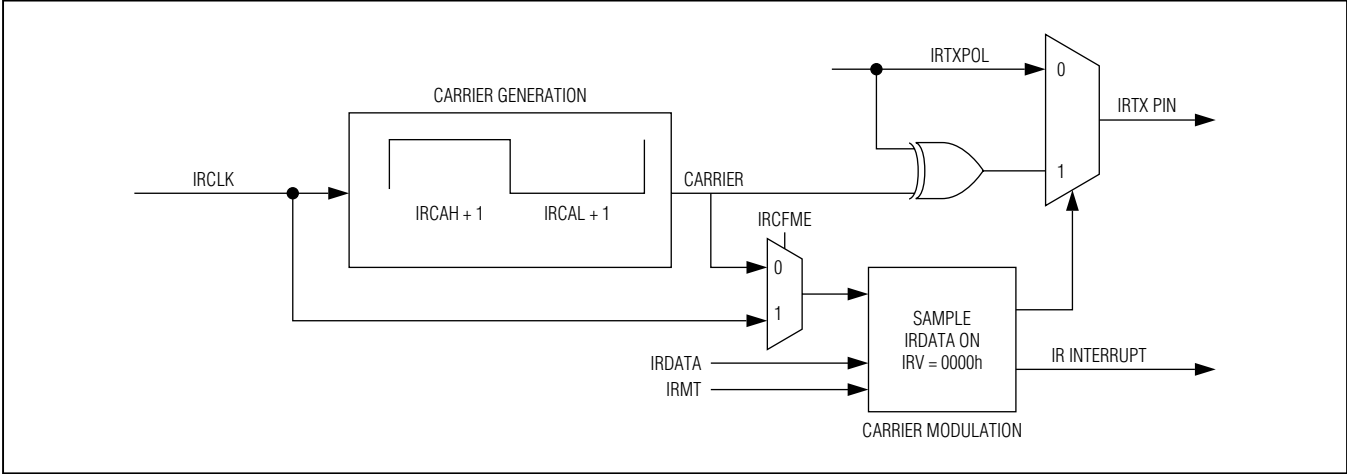

Figure 2. IR Transmit Carrier Generation and Carrier Modulator Control

Infrared Remote Control System-on-Chip

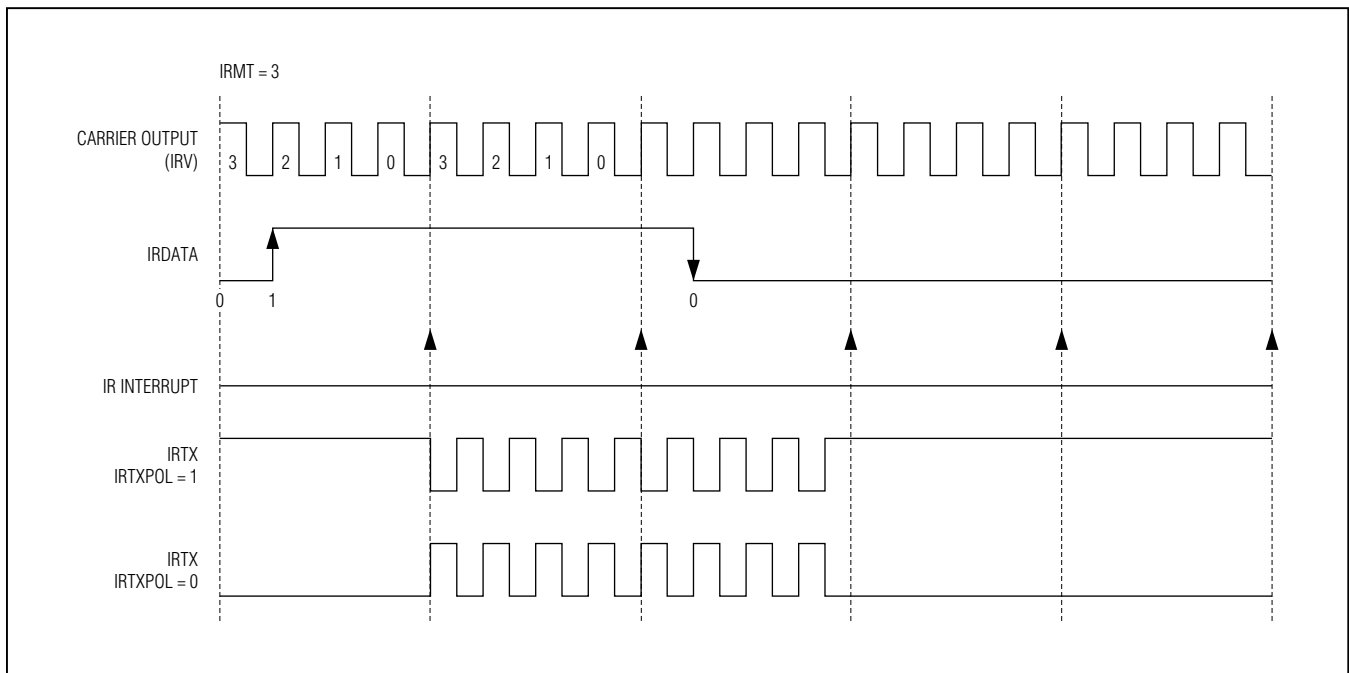

Figure 3. IR Transmission Waveform (IRCFME = 0)

IR Receive

When configured in receive mode (IRMODE = 0), the IR hardware supports the IRRX capture function. The IRRXSEL[1:0] bits define which edge(s) of the IRRX pin should trigger the IR timer capture function.

The IR module starts operating in the receive mode when IRMODE = 0 and IREN = 1. Once started, the IR timer (IRV) starts up counting from 0000h when a qualified capture event as defined by IRRXSEL happens. The IRV register is, by default, counting carrier cycles as defined by the IRCA register. However, the IR carrier frequency detect (IRCFME) bit can be set to 1 to allow clocking of the IRV register directly with the IRCLK for finer resolution. When IRCFME = 0, the IRCA defined carrier is counted by IRV. When IRCFME = 1, the IRCLK clocks the IRV register (Figure 4).

On the next qualified event, the IR module does the following:

- 1) Captures the IRRX pin state and transfers its value to IRDATA. If a falling edge occurs, IRDATA = 0. If a rising edge occurs, IRDATA = 1.
- 2) Transfers its current IRV value to the IRMT.
- 3) Resets IRV content to 0000h (if IRXRL = 1).
- 4) Continues counting again until the next qualified event.

If the IR timer value rolls over from 0FFFFh to 0000h before a qualified event happens, the IR timer overflow (IROV) flag is set to 1 and an interrupt is generated, if enabled. The IR module continues to operate in receive mode until it is stopped by switching into transmit mode (IRMODE = 1) or clearing IREN = 0.

Infrared Remote Control System-on-Chip

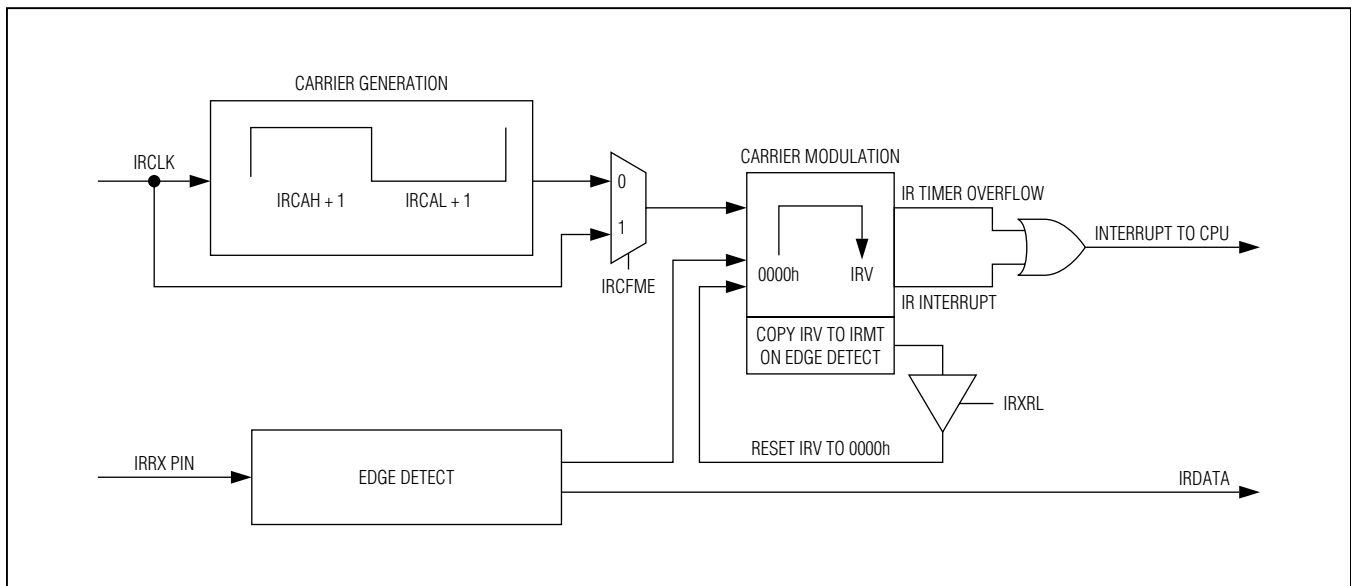

Figure 4. IR Capture

Carrier Burst-Count Mode

A special mode reduces the CPU processing burden when performing IR learning functions. Typically, when operating in an IR learning capacity, some number of carrier cycles are examined for frequency determination. Once the frequency has been determined, the IR receive function can be reduced to counting the number of carrier pulses in the burst and the duration of the combined mark-space time within the burst. To simplify this process, the receive burst-count mode (as enabled by the **RXBCNT** bit) can be used. When **RXBCNT = 0**, the standard IR receive capture functionality is in place. When **RXBCNT = 1**, the **IRV** capture operation is disabled and the interrupt flag associated with the capture no longer denotes a capture. In the carrier burst-count mode, the **IRMT** register only counts qualified edges. The **IRIF** interrupt flag (normally used to signal a capture when **RXBCNT = 0**) now becomes set if two **IRCA** cycles elapse without getting a qualified edge. The **IRIF** interrupt flag thus denotes absence of the carrier and the beginning of a space in the receive signal. When the **RXBCNT** bit is changed from 0 to 1, the **IRMT** register is set to 0001h. The **IRCFME** bit is still used to define

whether the **IRV** register is counting system **IRCLK** clocks or **IRCA**-defined carrier cycles. The **IRXRL** bit defines whether the **IRV** register is reloaded with 0000h on detection of a qualified edge (per the **IRRXSEL[1:0]** bits). Figure 5 and the descriptive sequence embedded in the figure illustrate the expected usage of the receive burst-count mode.

16-Bit Timers/Counters

The microcontroller provides two timers/counters that support the following functions:

- 16-bit timer/counter
- 16-bit up/down autoreload
- Counter function of external pulse
- 16-bit timer with capture
- 16-bit timer with compare
- Input/output enhancements for pulse-width modulation
- Set/reset/toggle output state on comparator match
- Prescaler with 2^n divider (for $n = 0, 2, 4, 6, 8, 10$)

Infrared Remote Control System-on-Chip

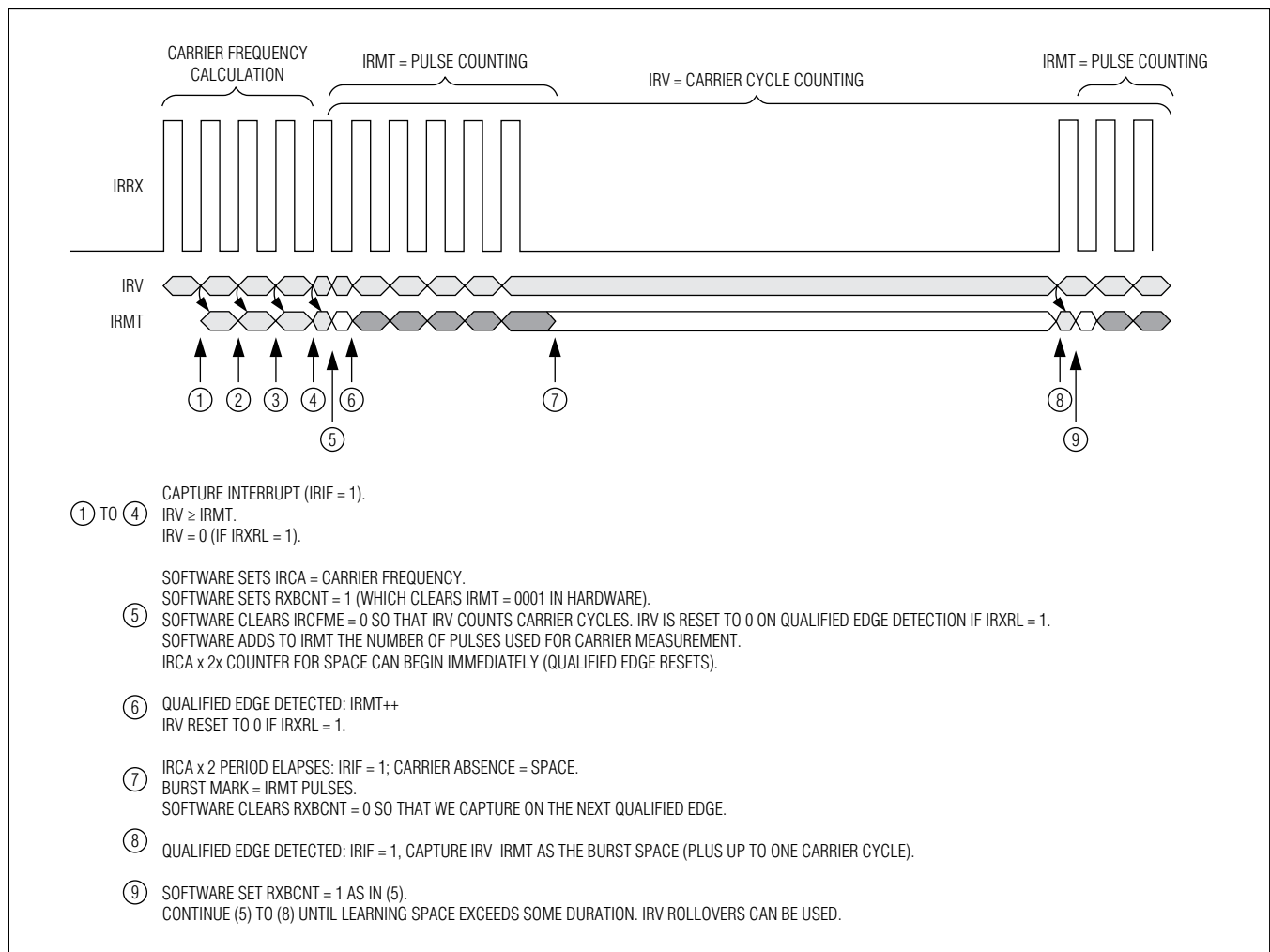

Figure 5. Receive Burst-Count Example

Serial Peripherals

Serial Peripheral Interface (SPI)

The device provides two SPI ports. The SPI is an inter-device bus protocol that provides fast, synchronous, full-duplex communications between devices. The integrated SPI interface acts as either an SPI master or slave device. The master drives the synchronous clock and selects which of several slaves is being addressed. Every SPI peripheral consists of a single shift register and control circuitry so that an addressed serial peripheral interface SPI peripheral is simultaneously transmitting and receiving. The maximum SPI master transfer rate is Sysclk/2.

When operating as an SPI slave, the device can support up to Sysclk/4 SPI transfer rate. Data can be transferred as an 8-bit or 16-bit value, MSB first. In addition, the SPI module supports configuration of the active SSEL state through the slave active-select pin.

Four signals are used in SPI communication:

- **SCLK:** The synchronous clock used by all devices. The master drives this clock and the slaves receive the clock. Note that SCLK can be gated and need not be driven between SPI transactions.
- **MOSI:** Master out-slave in. This is the main data line driven by the master to all slaves on the SPI bus. Only the selected slave clocks data from MOSI.

Infrared Remote Control System-on-Chip

- **MISO:** Master in-slave out. This is the main data line driven by the selected slave to the master. Only the selected slave may drive this circuit. In fact, it is the only circuit in the SPI bus arrangement that a slave is ever permitted to drive.
- **SSEL:** This signal is unique to each slave. When active (generally low), the selected slave must drive MISO.

I²C Bus

The microcontroller provides two internal I²C bus master/slave peripherals for communication with a wide variety of other I²C-enabled devices. The I²C bus is a 2-wire, bidirectional bus using two bus lines—the serial data line (SDA) and the serial clock line (SCL)—and a ground line. Both the SDA and SCL lines must be driven as open-collector/drain outputs. External resistors are required to pull the lines to a logic-high state.

The device supports both the master and slave protocols. In the master mode, the device has ownership of the I²C bus, drives the clock, and generates the START and STOP signals. This allows it to send data to a slave or receive data from a slave as required. In slave mode, the device relies on an externally generated clock to drive SCL and responds to data and commands only when requested by the I²C master device.

USART

The device provides two USART peripherals with operation modes described in [Table 2](#). The USART provides the following features:

- 2-wire interface
- Full-duplex operation for asynchronous data transfers
- Half-duplex operation for synchronous data transfers
- Programmable interrupt when transmit or receive data operation completes
- Independent programmable baud-rate generator
- Optional 9th bit parity support
- Start/stop bit support

Table 2. USART Mode Details

MODE	TYPE	START BITS	DATA BITS	STOP BITS
Mode 0	Synchronous	N/A	8	N/A
Mode 1	Asynchronous	1	8	1
Mode 2	Asynchronous	1	8 + 1	1
Mode 3	Asynchronous	1	8 + 1	1

General-Purpose I/O

The microcontroller provides port pins for general-purpose I/O that have the following features:

- CMOS output drivers
- Schmitt trigger inputs
- Optional weak pullup to V_{DD} when operating in input mode

While the microcontroller is in a reset state, all port pins become high impedance with both weak pullups and input buffers disabled, unless otherwise noted.

From a software perspective, each port appears as a group of peripheral registers with unique addresses. Special function pins can also be used as general-purpose I/O pins when the special functions are disabled. For a detailed description of the special functions available for each pin, refer to the *User's Guide*.

On-Chip Oscillator

The device provides an internal 12MHz oscillator that requires no external components, thereby reducing system cost, PCB area, and radiated EMI.

Operating Modes

The lowest power mode of operation is stop mode. In this mode, CPU state and memories are preserved, but the CPU is not actively running. Wake-up sources include external I/O interrupts, the power-fail warning interrupt, wake-up timer, or a power-fail reset. Any time the microcontroller is in a state where code does not need to be executed, the user software can put the device into stop mode. The nanopower ring oscillator is an internal ultra-low-power (400nA) 8kHz ring oscillator that can be used to drive a wake-up timer that exits stop mode. The wake-up timer is programmable by software in steps of 125μs up to approximately 8s.

Infrared Remote Control System-on-Chip

The power-fail monitor is always on during normal operation. However, it can be selectively disabled during stop mode to minimize power consumption. This feature is enabled using the power-fail monitor disable (PFD) bit in the PWCN register. The reset default state for the PFD bit is 1, which disables the power-fail monitor function during stop mode. If power-fail monitoring is disabled (PFD = 1) during stop mode, the circuitry responsible for generating a power-fail warning or reset is shut down and neither condition is detected. Thus, the $V_{DD} < V_{RST}$ condition does not invoke a reset state.

Power-Fail Detection

Figure 6, Figure 7, Figure 8, Table 4, Table 5, and Table 6 show the power-fail detection and response during normal and stop-mode operation. If a reset is caused by a power-fail, the power-fail monitor can be set to one of the following intervals:

- Always on—continuous monitoring
- 2^{11} nanopower ring oscillator clocks (~256ms)
- 2^{12} nanopower ring oscillator clocks (~512ms)
- 2^{13} nanopower ring oscillator clocks (~1.024s)

In the case where the power-fail circuitry is periodically turned on, the power-fail detection is turned on for two

nanopower ring-oscillator cycles. If $V_{DD} > V_{RST}$ during detection, V_{DD} is monitored for an additional nanopower ring-oscillator period. If V_{DD} remains above V_{RST} for the third nanopower ring period, the CPU exits the reset state and resumes normal operation from utility ROM at 8000h after satisfying the crystal warmup period.

The voltage (V_{PFW}) below which a power-fail warning is generated is user-configurable through the power-fail warning trip point control (PFWARNCN) bits. Table 3 shows the supported V_{PFW} values.

If a reset is generated by any other event, such as the \overline{RESET} pin being driven low externally or the watch-dog timer, the power-fail, internal regulator, and crystal remain on during the CPU reset. In these cases, the CPU exits the reset state in less than 20 crystal cycles after the reset source is removed.

Table 3. Power-Fail Warning Voltage Selection

PFWARNCN	NOMINAL VOLTAGE
00	1.67
01	1.9
10	2.5
11	2.7

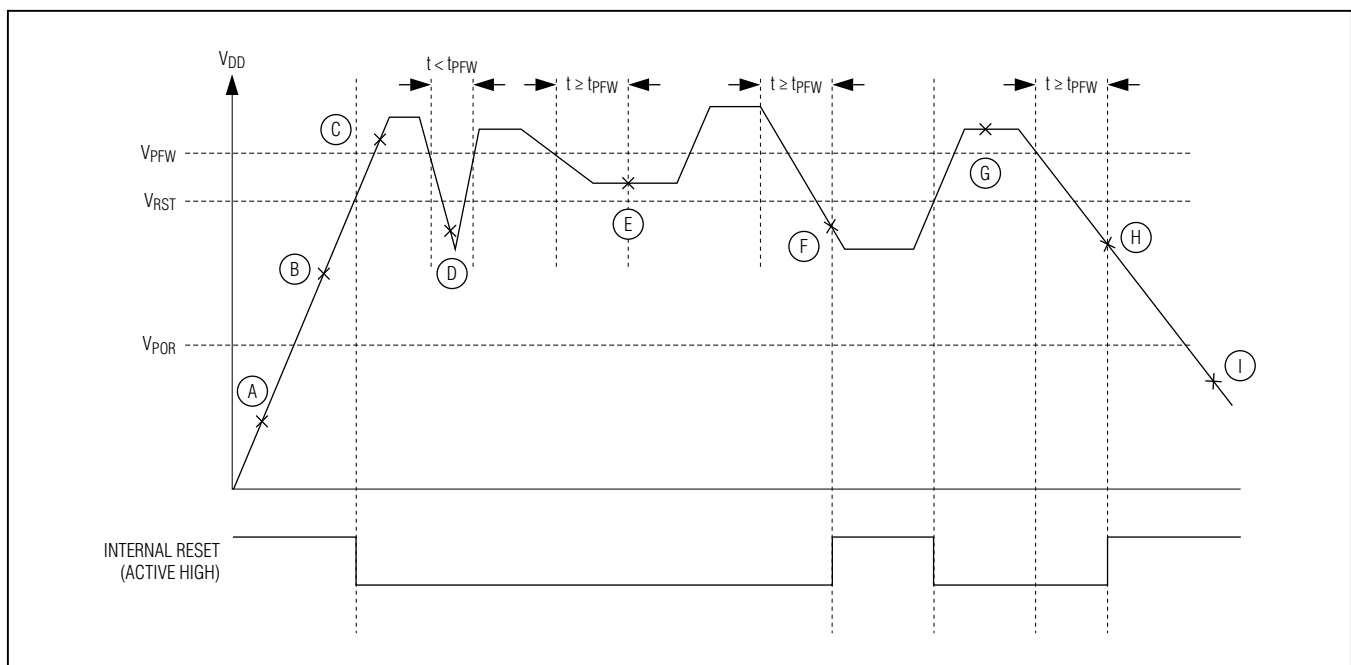

Figure 6. Power-Fail Detection During Normal Operation

Infrared Remote Control System-on-Chip

Table 4. Power-Fail Detection States During Normal Operation

STATE	POWER-FAIL	INTERNAL REGULATOR	CRYSTAL OSCILLATOR	SRAM RETENTION	COMMENTS
A	On	Off	Off	—	$V_{DD} < V_{POR}$.
B	On	On	On	—	$V_{POR} < V_{DD} < V_{RST}$. Crystal warmup time, t_{XTAL_RDY} . CPU held in reset.
C	On	On	On	—	$V_{DD} > V_{RST}$. CPU normal operation.
D	On	On	On	—	Power drop too short. Power-fail not detected.
E	On	On	On	—	$V_{RST} < V_{DD} < V_{PFW}$. PFI is set when $V_{RST} < V_{DD} < V_{PFW}$ and maintains this state for at least t_{PFW} , at which time a power-fail interrupt is generated (if enabled). CPU continues normal operation.
F	On (Periodically)	Off	Off	Yes	$V_{POR} < V_{DD} < V_{RST}$. Power-fail detected. CPU goes into reset. Power-fail monitor turns on periodically.
G	On	On	On	—	$V_{DD} > V_{RST}$. Crystal warmup time, t_{XTAL_RDY} . CPU resumes normal operation from 8000h.
H	On (Periodically)	Off	Off	Yes	$V_{POR} < V_{DD} < V_{RST}$. Power-fail detected. CPU goes into reset. Power-fail monitor turns on periodically.
I	Off	Off	Off	—	$V_{DD} < V_{POR}$. Device held in reset. No operation allowed.

Infrared Remote Control System-on-Chip

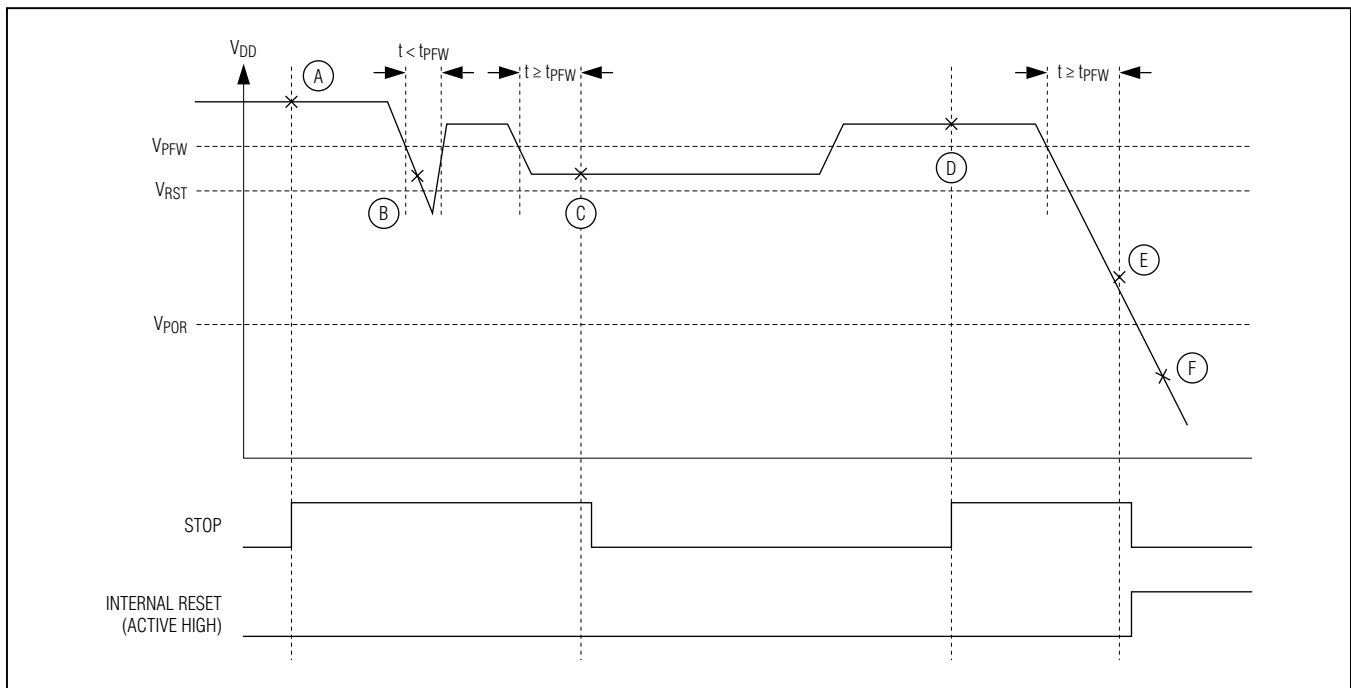

Figure 7. Stop Mode Power-Fail Detection States with Power-Fail Monitor Enabled

Table 5. Stop Mode Power-Fail Detection States with Power-Fail Monitor Enabled

STATE	POWER-FAIL	INTERNAL REGULATOR	CRYSTAL OSCILLATOR	SRAM RETENTION	COMMENTS
A	On	Off	Off	Yes	Application enters stop mode. $V_{DD} > V_{RST}$. CPU in stop mode.
B	On	Off	Off	Yes	Power drop too short. Power-fail not detected.
C	On	On	On	Yes	$V_{RST} < V_{DD} < V_{PFW}$. Power-fail warning detected. Turn on regulator and crystal. Crystal warmup time, t_{XTAL_RDY} . Exit stop mode.
D	On	Off	Off	Yes	Application enters stop mode. $V_{DD} > V_{RST}$. CPU in stop mode.
E	On (Periodically)	Off	Off	Yes	$V_{POR} < V_{DD} < V_{RST}$. Power-fail detected. CPU goes into reset. Power-fail monitor turns on periodically.
F	Off	Off	Off	—	$V_{DD} < V_{POR}$. Device held in reset. No operation allowed.

Infrared Remote Control System-on-Chip

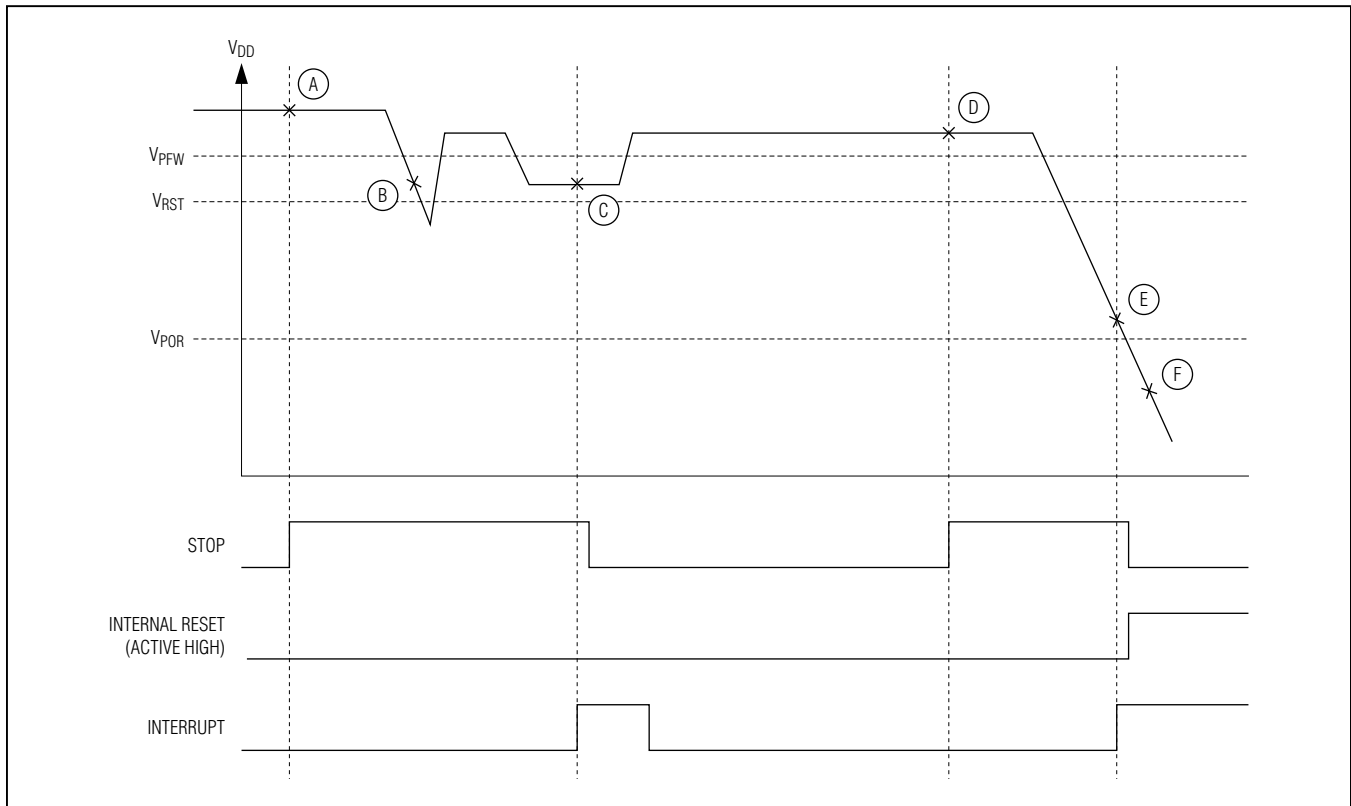

Figure 8. Stop Mode Power-Fail Detection with Power-Fail Monitor Disabled

Table 6. Stop Mode Power-Fail Detection States with Power-Fail Monitor Disabled

STATE	POWER-FAIL	INTERNAL REGULATOR	CRYSTAL OSCILLATOR	SRAM RETENTION	COMMENTS
A	Off	Off	Off	Yes	Application enters stop mode. $V_{DD} > V_{RST}$. CPU in stop mode.
B	Off	Off	Off	Yes	$V_{DD} < V_{PFW}$. Power-fail not detected because power-fail monitor is disabled.
C	On	On	On	Yes	$V_{RST} < V_{DD} < V_{PFW}$. An interrupt occurs that causes the CPU to exit stop mode. Power-fail monitor is turned on, detects a power-fail warning, and sets the power-fail interrupt flag. Turn on regulator and crystal. Crystal warmup time, t_{XTAL_RDY} . On stop mode exit, CPU vectors to the higher priority of power-fail and the interrupt that causes stop mode exit.

Infrared Remote Control System-on-Chip

Table 6. Stop Mode Power-Fail Detection States with Power-Fail Monitor Disabled (continued)

STATE	POWER-FAIL	INTERNAL REGULATOR	CRYSTAL OSCILLATOR	SRAM RETENTION	COMMENTS
D	Off	Off	Off	Yes	Application enters stop mode. $V_{DD} > V_{RST}$. CPU in stop mode.
E	On (Periodically)	Off	Off	Yes	$V_{POR} < V_{DD} < V_{RST}$. An interrupt occurs that causes the CPU to exit stop mode. Power-fail monitor is turned on, detects a power-fail, and puts CPU in reset. Power-fail monitor is turned on periodically.
F	Off	Off	Off	—	$V_{DD} < V_{POR}$. Device held in reset. No operation allowed.

Applications Information

The low-power, high-performance RISC architecture of this device makes it an excellent fit for many portable or battery-powered applications. It is ideally suited for applications such as universal remote controls that require the cost-effective integration of IR transmit/receive capability.

Grounds and Bypassing

Careful PCB layout significantly minimizes system-level digital noise that could interact with the microcontroller or peripheral components. The use of multilayer boards is essential to allow the use of dedicated power planes. The area under any digital components should be a continuous ground plane if possible. Keep bypass capacitor leads short for best noise rejection and place the capacitors as close to the leads of the devices as possible.

CMOS design guidelines for any semiconductor require that no pin be taken above V_{DD} or below GND. Violation of this guideline can result in a hard failure (damage to the silicon inside the device) or a soft failure (unintentional modification of memory contents). Voltage spikes above or below the device's absolute maximum ratings can potentially cause a devastating IC latchup.

Microcontrollers commonly experience negative voltage spikes through either their power pins or general-purpose I/O pins. Negative voltage spikes on power pins are especially problematic as they directly couple to the internal power buses. Devices such as keypads can conduct electrostatic discharges directly into the microcontroller and seriously damage the device. System designers must protect components against these transients that can corrupt system memory.

MAXQ617

Infrared Remote Control System-on-Chip

Additional Documentation

Engineers must have the following documents to fully use this device:

- This data sheet, containing pin descriptions, feature overviews, and electrical specifications.
- The device-appropriate user guide, containing detailed information and programming guidelines for core features and peripherals.
- Errata sheets for specific revisions noting deviations from published specifications.

For information regarding these documents, visit Technical Support at support.maximintegrated.com/micro.

Development and Technical Support

Contact technical support for information about highly versatile, affordable development tools, available from Maxim Integrated and third-party vendors.

- Evaluation kits
- Compilers
- Integrated development environments (IDEs)
- USB interface modules for programming and debugging

For technical support, go to support.maximintegrated.com/micro.

Ordering Information/Selector Guide

PART	TEMP RANGE	OPERATING VOLTAGE (V)	PROGRAM MEMORY (KB)	DATA MEMORY (KB)	GPIO	PIN-PACKAGE
MAXQ617V-XXXX+T	-20°C to +70°C	1.67 to 3.6	80 Flash	4	10	16 WLP

Note: The 4-digit suffix “-XXXX” indicates a device preprogrammed at Maxim Integrated with proprietary customer-supplied software. For more information on factory preprogramming of this device, contact Maxim Integrated at support.maximintegrated.com/micro.

+Denotes a lead(Pb)-free/RoHS-compliant package.

T = Tape and reel.

Package Information

For the latest package outline information and land patterns (footprints), go to www.maximintegrated.com/packages. Note that a “+”, “#”, or “-” in the package code indicates RoHS status only. Package drawings may show a different suffix character, but the drawing pertains to the package regardless of RoHS status.

PACKAGE TYPE	PACKAGE CODE	OUTLINE NO.	LAND PATTERN NO.
16 WLP	W162K2+1	21-0491	Refer to Application Note 1891

Infrared Remote Control System-on-Chip

Appendix A

I²C SERIAL PERIPHERAL SPECIFICATIONS

(Figure 9 and Figure 10)

PARAMETER	SYMBOL	CONDITIONS	STANDARD MODE		FAST MODE		UNITS
			MIN	MAX	MIN	MAX	
Input Low Voltage	V _{IL_I2C}	Supply voltages that mismatch I ² C bus levels must relate input levels to the R _P pullup voltage	-0.5	0.3 × V _{DD}	-0.5	0.3 × V _{DD}	V
Input High Voltage	V _{IH_I2C}	Supply voltages that mismatch I ² C bus levels must relate input levels to the R _P pullup voltage	0.7 × V _{DD}		0.7 × V _{DD}	V _{DD} + 0.5V	V
Input Hysteresis (Schmitt)	V _{IHYS_I2C}	V _{DD} > 2V			0.05 × V _{DD}		V
Output Logic-Low (Open Drain or Open Collector)	V _{OL_I2C}	V _{DD} > 2V, 3mA sink current	0	0.4	0	0.4	V
Capacitive Load for Each Bus Line	C _B		400		400		pF
Output Fall Time from V _{IH_MIN} to V _{IL_MAX} with Bus Capacitance from 10pF to 400pF	t _{OF_I2C}	t _{RF_I2C} exceeds t _{OF_I2C} , which permits RS to be connected as shown in figure	250		20 + 0.1C _B	250	ns
Pulse Width of Spike Filtering That Must Be Suppressed by Input Filter	t _{SP_I2C}				0	50	ns
Input Current on I/O	I _{IN_I2C}	Input voltage from 0.1 × V _{DD} to 0.9 × V _{DD}	-10	+10	-10	+10	μA
I/O Capacitance	C _{IO_I2C}		10		10		pF
I ² C Bus Operating Frequency	f _{I2C}		0	100	0	400	kHz
System Frequency	f _{SYS}		0.90		3.60		MHz
I ² C Bit Rate	f _{I2C}		f _{SYS} /8		f _{SYS} /8		Hz
Hold Time After (Repeated) START	t _{HD:STA}		4.0		0.6		μs
Clock Low Period	t _{LOW_I2C}		4.7		1.3		μs
Clock High Period	t _{HIGH_I2C}		4.0		0.6		μs
Setup Time for Repeated START	t _{SU:STA}		4.7		0.6		μs

Infrared Remote Control System-on-Chip

I²C SERIAL PERIPHERAL SPECIFICATIONS (continued)

(Figure 9 and Figure 10)

PARAMETER	SYMBOL	CONDITIONS	STANDARD MODE		FAST MODE		UNITS
			MIN	MAX	MIN	MAX	
Hold Time for Data	$t_{HD:DAT}$	A device must internally provide a hold time of at least 300ns for $V_{IH_I2C(MIN)}$ to bridge the undefined region of the falling edge of SCL. The maximum $t_{HD:DAT}$ needs to be met only if the device does not stretch the SCL low period	0	3.45	0	0.9	μ s
Setup Time for Data	$t_{SU:DAT}$	A fast-mode I ² C bus device can be used in a standard-mode I ² C bus system; if such a device does not stretch the low period of the SCL signal, it must output the next data bit to the SDA line $t_{R_I2C(MAX)} + t_{SU:DAT} = 1000 + 250 = 1250$ ns (according to the standard-mode I ² C specification) before the SCL line is released	250		100		ns
SDA/SCL Fall Time	t_{F_I2C}			300	20 + $0.1C_B$	300	ns
SDA/SCL Rise Time	t_{R_I2C}			1000	20 + $0.1C_B$	300	ns
Setup Time for STOP	$t_{SU:STO}$		4.0		0.6		μ s
Bus Free Time Between STOP and START	t_{BUF}		4.7		1.3		μ s
Noise Margin at the Low Level for Each Connected Device (Including Hysteresis)	V_{nL_I2C}		$0.1 \times V_{DD}$		$0.1 \times V_{DD}$		V
Noise Margin at the High Level for Each Connected Device (Including Hysteresis)	V_{nH_I2C}		$0.2 \times V_{DD}$		$0.2 \times V_{DD}$		V

Infrared Remote Control System-on-Chip

I²C Serial Diagrams

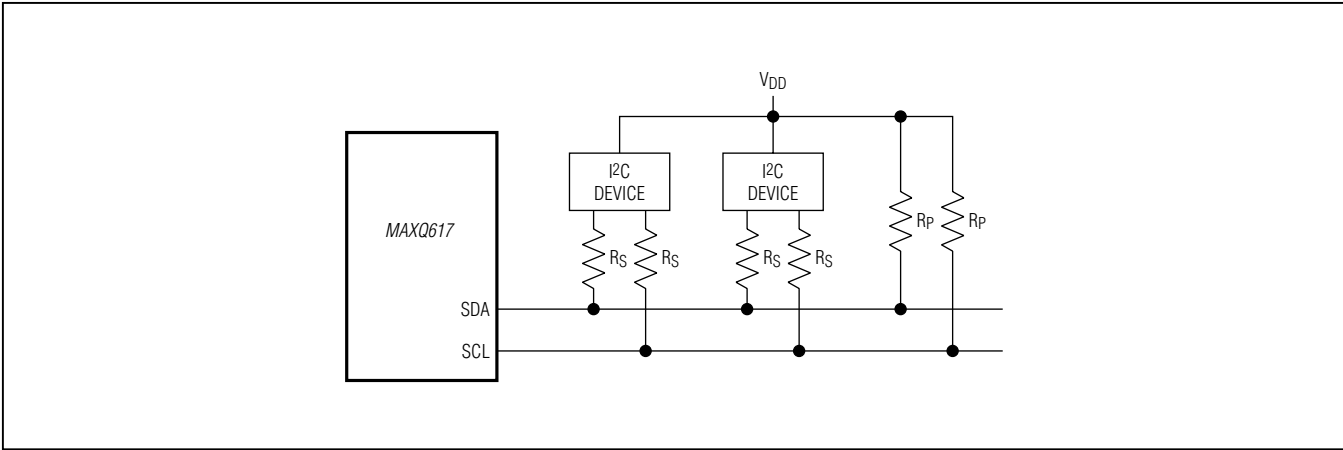

Figure 9. Series Resistors (R_S) for Protecting Against High-Voltage Spikes

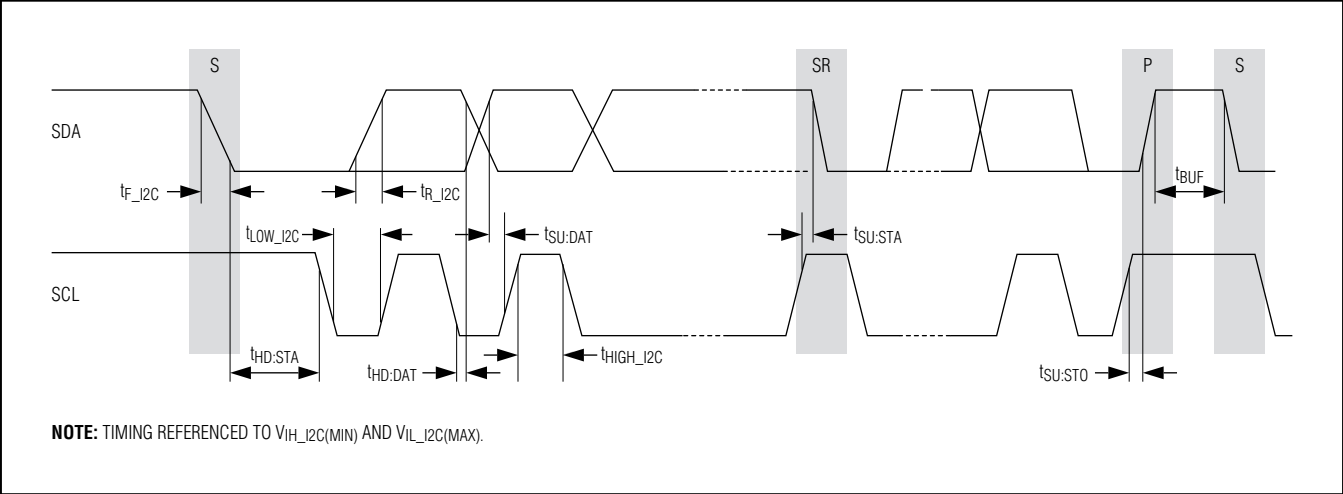

Figure 10. I²C Bus Controller Timing Diagram

Infrared Remote Control System-on-Chip**SERIAL PERIPHERAL INTERFACE (SPI) SPECIFICATIONS**

(Figure 11 and Figure 12)

PARAMETER	SYMBOL	CONDITIONS	MIN	TYP	MAX	UNITS
SPI Master Operating Frequency	$1/t_{MCK}$				$f_{CK}/2$	MHz
SPI Slave Operating Frequency	$1/t_{SCK}$				$f_{CK}/4$	MHz
SCLK Output Pulse-Width High/Low	t_{MCH} , t_{MCL}		$t_{MCK}/2$ - 35			ns
MOSI Output Hold Time After SCLK Sample Edge	t_{MOH}		$t_{MCK}/2$ - 35			ns
MOSI Output Valid to Sample Edge	t_{MOV}		$t_{MCK}/2$ - 35			ns
MISO Input Valid to SCLK Sample Edge Rise/Fall Setup	t_{MIS}		35			ns
MISO Input to SCLK Sample Edge Rise/Fall Hold	t_{MIH}		0			ns
SCLK Input Pulse-Width High/Low	t_{SCH} , t_{SCL}			$t_{SCK}/2$		ns
SSEL Active to First Shift Edge	t_{SSE}			50		ns
MOSI Input to SCLK Sample Edge Rise/Fall Setup	t_{SIS}		35			ns
MOSI Input from SCLK Sample Edge Transition Hold	t_{SIH}		35			ns
MISO Output Valid After SCLK Shift Edge Transition	t_{SOV}				70	ns
SCLK Inactive to SSEL Rising	t_{SD}		35			ns

Infrared Remote Control System-on-Chip

SPI Timing Diagrams

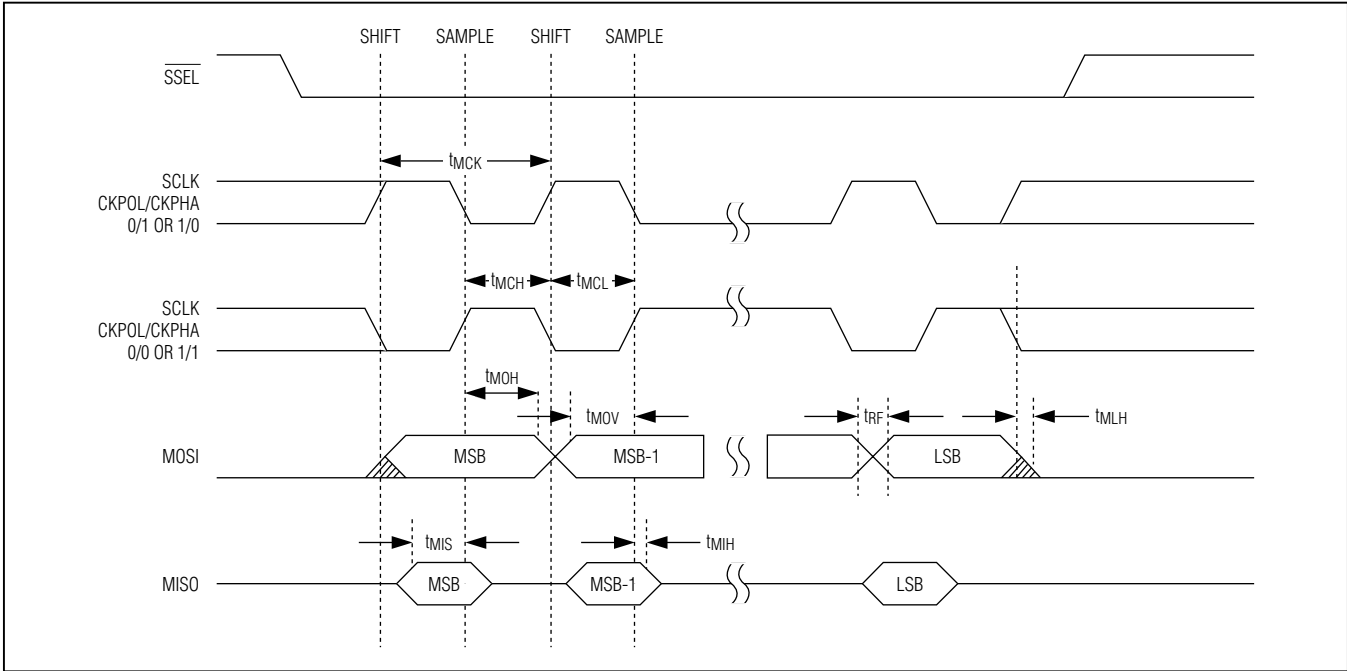

Figure 11. SPI Master Communication Timing

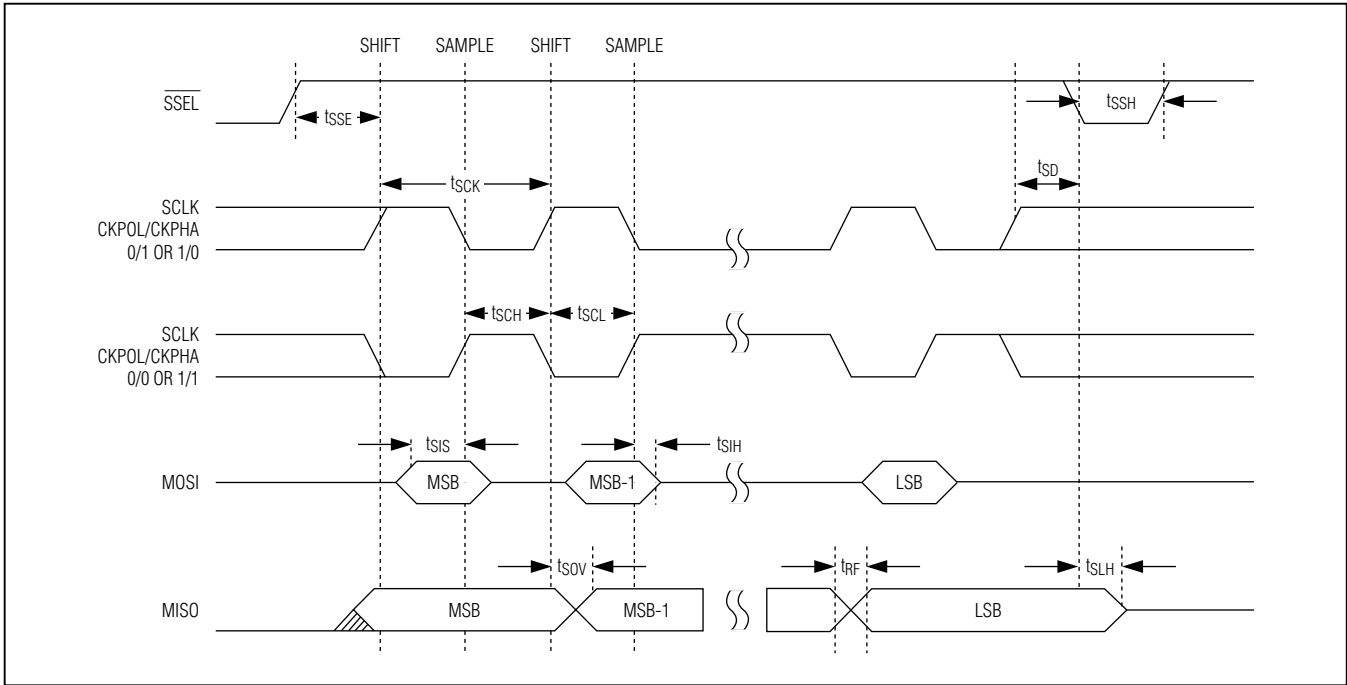

Figure 12. SPI Slave Communication Timing

Infrared Remote Control System-on-Chip

USART MODE 0 SPECIFICATIONS

PARAMETER	SYMBOL	CONDITIONS	MIN	TYP	MAX	UNITS
TXD Clock Period	t_{XLXL}	SM2 = 0		$12t_{CLCL}$		ns
		SM2 = 1		$4t_{CLCL}$		ns
TXD Clock High Time	t_{XHXL}	SM2 = 0		$3t_{CLCL}$		ns
		SM2 = 1		$2t_{CLCL}$		ns
RXD Output Data Valid to TXD Clock Rising Edge	t_{QVXH}	SM2 = 0		$10t_{CLCL}$		ns
		SM2 = 1		$3t_{CLCL}$		ns
RXD Output Data Hold from TXD Clock Rising Edge	t_{XHQH}	SM2 = 0		$2t_{CLCL}$		ns
		SM2 = 1		t_{CLCL}		ns
RXD Input Data Valid to TXD Clock Rising Edge	t_{DVXH}	SM2 = 0		t_{CLCL}		ns
		SM2 = 1		t_{CLCL}		ns
RXD Input Data Hold after TXD Clock Rising Edge	t_{XHDH}	SM2 = 0		t_{CLCL}		ns
		SM2 = 1		t_{CLCL}		ns

USART Timing

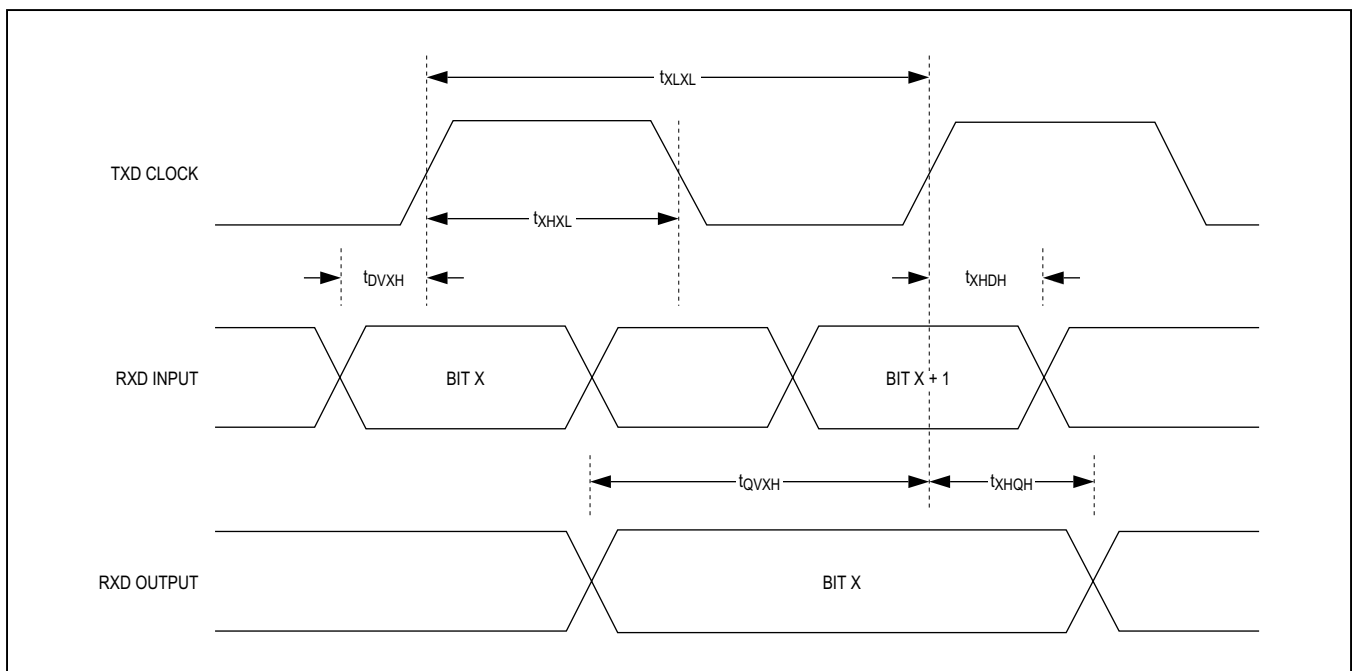

Figure 13. USART Timing Diagram

MAXQ617

Infrared Remote Control System-on-Chip

Revision History

REVISION NUMBER	REVISION DATE	DESCRIPTION	PAGES CHANGED
0	12/13	Initial release	—



Maxim Integrated cannot assume responsibility for use of any circuitry other than circuitry entirely embodied in a Maxim Integrated product. No circuit patent licenses are implied. Maxim Integrated reserves the right to change the circuitry and specifications without notice at any time. The parametric values (min and max limits) shown in the Electrical Characteristics table are guaranteed. Other parametric values quoted in this data sheet are provided for guidance.

Maxim Integrated 160 Rio Robles, San Jose, CA 95134 USA 1-408-601-1000

29



Стандарт Электрон Связь

Мы молодая и активно развивающаяся компания в области поставок электронных компонентов. Мы поставляем электронные компоненты отечественного и импортного производства напрямую от производителей и с крупнейших складов мира.

Благодаря сотрудничеству с мировыми поставщиками мы осуществляем комплексные и плановые поставки широчайшего спектра электронных компонентов.

Собственная эффективная логистика и склад в обеспечивает надежную поставку продукции в точно указанные сроки по всей России.

Мы осуществляем техническую поддержку нашим клиентам и предпродажную проверку качества продукции. На все поставляемые продукты мы предоставляем гарантию .

Осуществляем поставки продукции под контролем ВП МО РФ на предприятия военно-промышленного комплекса России , а также работаем в рамках 275 ФЗ с открытием отдельных счетов в уполномоченном банке. Система менеджмента качества компании соответствует требованиям ГОСТ ISO 9001.

Минимальные сроки поставки, гибкие цены, неограниченный ассортимент и индивидуальный подход к клиентам являются основой для выстраивания долгосрочного и эффективного сотрудничества с предприятиями радиоэлектронной промышленности, предприятиями ВПК и научно-исследовательскими институтами России.

С нами вы становитесь еще успешнее!

Наши контакты:

Телефон: +7 812 627 14 35

Электронная почта: sales@st-electron.ru

Адрес: 198099, Санкт-Петербург,
Промышленная ул, дом № 19, литера Н,
помещение 100-Н Офис 331