

Product Overview

The QPC6222 is a dual-pole double-throw transfer switch designed for general purpose switching applications where RF port transfer (port swapping) control is needed. The low insertion loss along with excellent linearity performance makes the QPC6222 ideal for multi-mode GSM, EDGE, UMTS, and LTE applications.

The RF ports can be directly connected in 50Ω systems and control logic is compatible with +1.3V to +2.7V systems. The supply voltage is intended for connection to +2.8V systems but the device is operable from +2.4V to +3.5V.

The standard 12-pin QFN package and compact 2.0 mm x 2.0 mm size offers designers a compact, easy-to-use, switch component for quick integration into multimode, multi-band systems.



12 Pad 2.0 mm x 2.0 mm x 0.55 mm QFN Package

Key Features

- Low Insertion Loss
- High Port-to-Port Isolation
- Power Handling up to +35 dBm
- GPIO Interface for +1.3V to +2.7V Control Logic
- Broadband Performance Suitable for All Cellular Modulation Schemes up to 2.7 GHz
- Very Low Current Consumption
- Linearity and Harmonic Performance Ideally Suited for LTE Applications

Functional Block Diagram

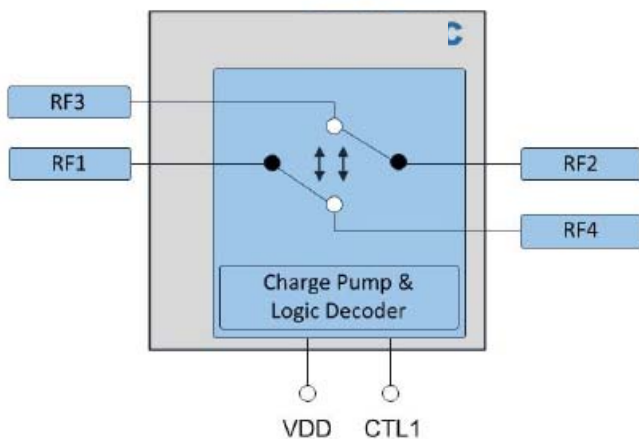

Functional Block Diagram

Top View

Applications

- Data Cards
- IoT
- Telemetry
- Automotive
- Cellular Modems and USB Devices
- Multi-Mode WCDMA, LTE Applications

Ordering Information

Part No.	Description
QPC6222SB	Sample Bag with 5 pieces
QPC6222SR	Sample Reel with 100 pieces
QPC6222PCK401	Assembled EVB + 5 Pieces Sample Bag
QPC6222TR13-5K	5000 Pieces Taped on 13" Reel

Absolute Maximum Ratings

Parameter	Rating
Storage Temperature	-65 to +150 °C
Operating Temperature (Tcase)	-40 to 105 °C
Maximum VDD	+4.5 V
Maximum CTRL	+3.0 V
Max Input Power (Momentary Infrequent Occurrence)	+38.5 dBm, 1:1 VSWR, +25°C +37.5 dBm, 1:1 VSWR, +90°C +35.0 dBm, 6:1 VSWR, +25°C +34.5 dBm, 6:1 VSWR, +90°C
Max Input Power (Continuous Operation)	+36.5 dBm, 1:1 VSWR, +25°C +35.5 dBm, 1:1 VSWR, +90°C +34.5 dBm, 6:1 VSWR, +25°C +34.0 dBm, 6:1 VSWR, +90°C

Exceeding any one or a combination of the Absolute Maximum Rating conditions may cause permanent damage to the device. Extended application of Absolute Maximum Rating conditions to the device may reduce device reliability.

Recommended Operating Conditions

Parameter	Min	Typ	Max	Units
Device Voltage (V _{DD})	+2.4	+2.8	+3.5	V
V _{DD} Supply Current		75	100	μA
C _{TL1} Logic Low Voltage	0.00	0.00	+0.45	V
C _{TL1} Logic High Voltage	+1.3	+1.8	+2.7	V
C _{TL1} Logic High Current		0.1	5	μA
Turn-On Time ⁽¹⁾			20	μs
Switching Time ⁽²⁾			5	μs

Electrical specifications are measured at specified test conditions. Specifications are not guaranteed over all recommended operating conditions.

Notes:

1. RF settling time with 0V to 2.4V step on VDD
2. Switching Time is measured at 10% to 90% RF

Electrical Specifications Low Band

Parameter	Conditions ⁽¹⁾	Min	Typ	Max	Units
Operational Frequency Range		698		960	MHz
Insertion Loss	RF1 to RF3 Logic State = RF1 – RF3, RF2 – RF4		0.35	0.52	dB
	RF1 to RF4 Logic State = RF1 – RF4, RF2 – RF3		0.35	0.52	
	RF2 to RF3 Logic State = RF1 – RF4, RF2 – RF3		0.35	0.52	
	RF2 to RF4 Logic State = RF1 – RF3, RF2 – RF4		0.34	0.52	
Isolation	RF1 to RF3, RF2 to RF4 Logic State = RF1 – RF4, RF2 – RF3	29	32		dB
	RF1 to RF4, RF2 to RF3 Logic State = RF1 – RF3, RF2 – RF4	28	31		
Harmonics	2nd Harmonic	Frequency = 824 MHz, PIN = +35 dBm, CW	-105	-76	dBc
	3rd Harmonic		-88	-76	dBc
	2nd Harmonic (B13)	Frequency = 786.5 MHz, PIN = +26 dBm, CW	-106	-98	dBc
	2nd Harmonic	Frequency = 824 MHz to 915 MHz, PIN = +26 dBm, CW	-107	-100	dBc
	3rd Harmonic		-106	-98	dBc
	Up to 12.75 GHz		-105	-95	dBc
IP2 Band 5 & 6	F1 = 836.5 MHz, P _{F1} = +20 dBm, F2 = 1718 MHz, P _{F2} = -15 dBm, Rx Freq. = 881.5 MHz	110	128		dBm
IP3 Band 5 & 6	F1 = 836.5 MHz, P _{F1} = +20 dBm, F2 = 791.5 MHz, P _{F2} = -15 dBm, Rx Freq = 881.5 MHz, Measured on all through paths	70	72		dBm
VSWR	824 MHz to 960 MHz (RF1, RF2, RF3, RF4)		1.1	1.3	

Notes:

1. Unless otherwise stated: all unused RF ports terminated in 50 Ω, Input and Output = 50 Ω, T. = +25 °C, V_{DD} = +2.4V, Logic State = RF1-RF4, RF2-RF3 and RF1-RF3, RF2-RF4

Electrical Specifications – High Band

Parameter		Conditions ⁽¹⁾	Min	Typ	Max	Units
Frequency Range			1427		2170	MHz
Insertion Loss	RF1 to RF3	Logic State = RF1-RF3; RF2-RF4	1427 to 1980 MHz	0.44	0.62	dB
			1980 to 2170 MHz	0.47	0.63	
	RF1 to RF4	Logic State = RF1-RF4; RF2-RF3	1427 to 1980 MHz	0.44	0.62	
			1980 to 2170 MHz	0.47	0.63	
	RF2 to RF3	Logic State = RF1-RF4, RF2-RF3	1427 to 1980 MHz	0.44	0.62	
			1980 to 2170 MHz	0.47	0.63	
	RF2 to RF4	Logic State = RF1-RF3, RF2-RF4	1427 to 1980 MHz	0.44	0.62	
			1980 to 2170 MHz	0.47	0.63	
Isolation	RF1 to RF3, RF2 to RF4	Logic State = RF1-RF4, RF2-RF3	1427 to 1980 MHz	23	27	dB
			1980 to 2170 MHz	22	26	
	RF1 to RF4, RF2 to RF3	Logic State = RF1-RF3, RF2-RF4	1427 to 1980 MHz	21	25	
			1980 to 2170 MHz	20	24	
Harmonics	2nd Harmonic	Frequency = 1980 MHz, P _{IN} = +33 dBm, CW, Measured on all through paths		-97	-75	dBc
	3rd Harmonic			-90	-70	
	2nd Harmonic	Freq. = 1710 MHz to 1980 MHz, P _{IN} = +26 dBm, CW, Measured on all through paths		-107	-98	
	3rd Harmonic			-104	-94	
	Up to 12.75 GHz			-104	-94	
IP2 Band 2 (PCS)		F1 = 836.5 MHz, P _{F1} = +20 dBm, F2 = 1718 MHz, P _{F2} = -15 dBm Rx Freq = 881.5 MHz, Measured on all through paths	+110	+126		dBm
IP3	Band II (PCS)	F1 = 1880 MHz, P _{F1} = +20 dBm, F2 = 1800 MHz, P _{F2} = -15 dBm Rx Freq = 1960 MHz, Measured on all through paths	+70	+73		dBm
	Band I (IMT)	F1 = 1950 MHz, P _{F1} = +20 dBm, F2 = 1760 MHz, P _{F2} = -15 dBm Rx Freq = 2140 MHz, Measured on all through paths	+70	+73		
VSWR RF1, RF2, RF3, RF4		1427 MHz to 2170 MHz		1.2	1.5	

Electrical Specifications – High Band LTE

Parameter		Conditions ⁽¹⁾	Min	Typ	Max	Units
Frequency Range			2500		2690	MHz
Insertion Loss		RFx to RFx		0.53		dB
Isolation	RF1 to RF3, RF2 to RF4	Logic State = RF1-RF4, RF2-RF3	21	24		dB
	RF1 to RF4, RF2 to RF3	Logic State = RF1-RF3, RF2-RF4	19	23		dB
Harmonics	2nd Harmonic	Frequency = 2500 MHz to 2570 MHz, P _{IN} = +26 dBm, CW, All through paths		-104	-95	dBc
	3rd Harmonic			-104	-95	dBc
VSWR RF1, RF2, RF3, RF4		2500 MHz to 2570 MHz		1.4	1.55	
IIP2		F1 = 2535 MHz at +20 dBm, F2 = 120 MHz at -15 dBm, Rx Freq = 2655 MHz	+110	+116		dBm
IIP3		F1 = 2535 MHz at +20 dBm, F2 = 2415 MHz at -15 dBm, Rx Freq. = 2655 MHz	+70	+72		dBm

Recommended Operating Power, 50 Ω System

Frequency	Power at T=+85 °C	Power at T=+105 °C	Theta-J(°C/W)	Input
5 MHz	+33 dBm	+30 dBm	246	Single RF path
20 MHz to 4 GHz	+36.5 dBm	+34.5 dBm	34.8	Single RF path
5 MHz	+32 dBm	+29 dBm	310	Dual RF path
20 MHz to 4 GHz	+35.5 dBm	+33.5 dBm	47	Dual RF path

Control Logic

Logic State	Description	V _{DD}	CTL1
Off	Off or Standby - low current state	0 V	Low
RF1-RF4, RF2-RF3	RF1 connected to RF4 and RF2 connected to RF3	"V _{DD} "	Low
RF1-RF3, RF2-RF4	RF1 connected to RF3 and RF2 connected to RF4	"V _{DD} "	High

NOTE: The switch is in the Off or Standby state only when the V_{DD} supply is low. The RF performance is undefined in the Off state.

Power ON and OFF sequence

It is very important that the user adheres to the correct power-on/off sequence in order to avoid damaging the device. First apply V_{DD} before applying a high to CTL1.

Power ON –

- 1) Apply voltage supply - V_{DD}
- 2) Apply logic signals - CTL1
- 3) Wait 5 μs or greater after CTL1 are stable and then apply the RF Signal

Power OFF –

- 1) Remove the RF Signal
- 2) Remove logic signals - CTL1
- 3) Remove voltage supply - V_{DD}

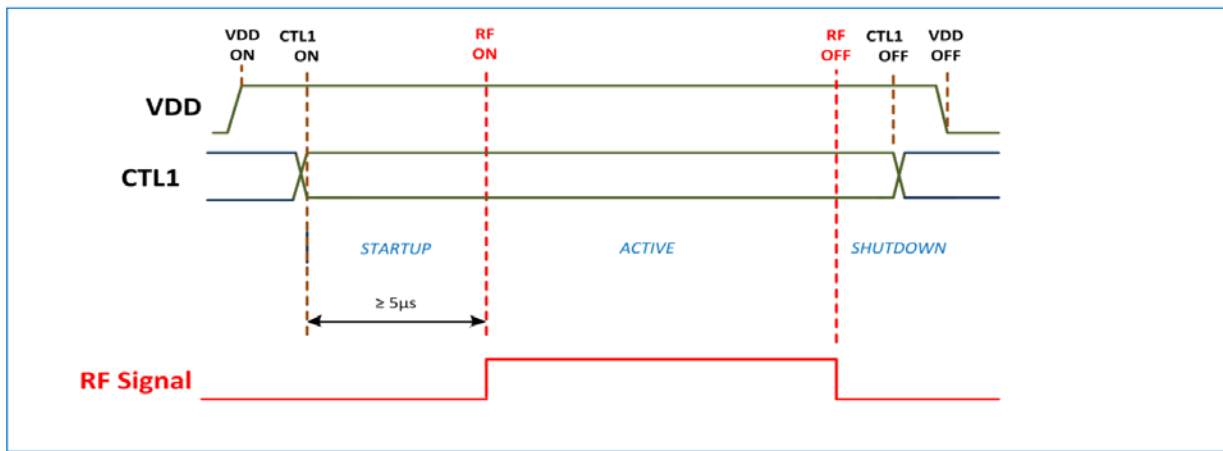

Performance Plots

Test conditions unless otherwise noted: $V_{DD} = +2.8V$

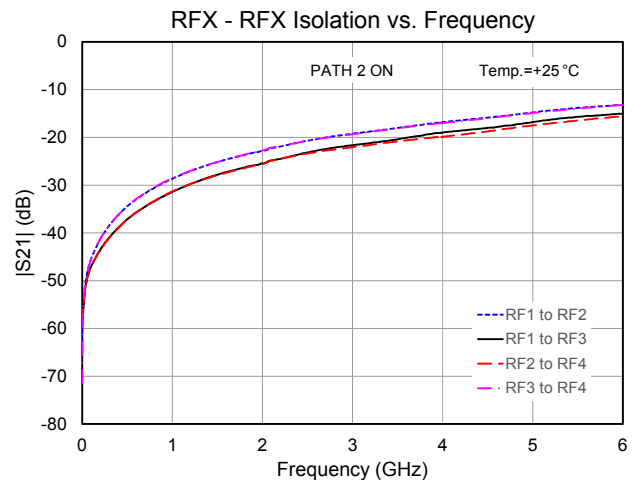
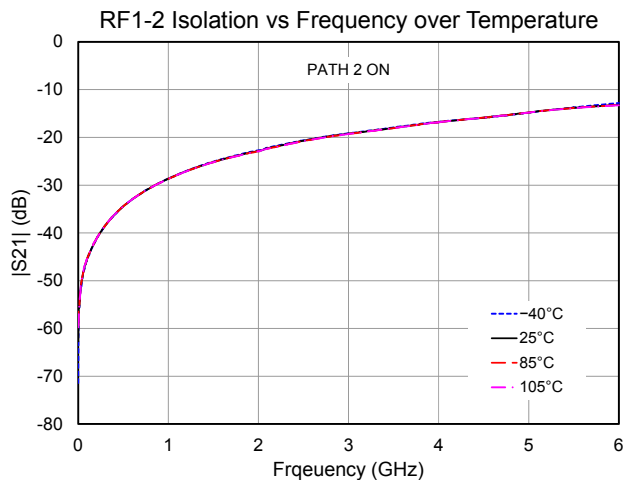
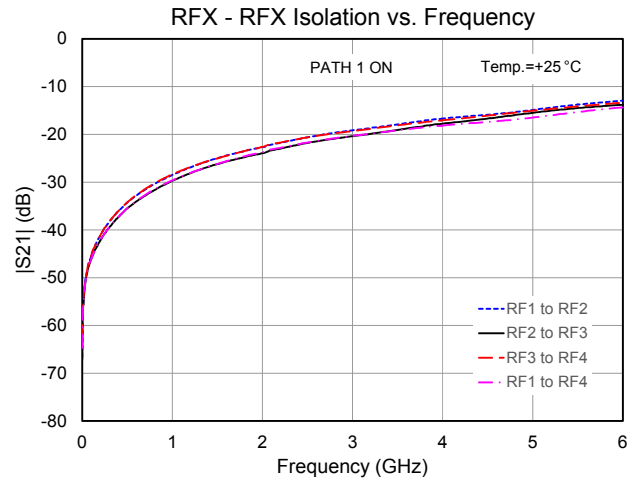
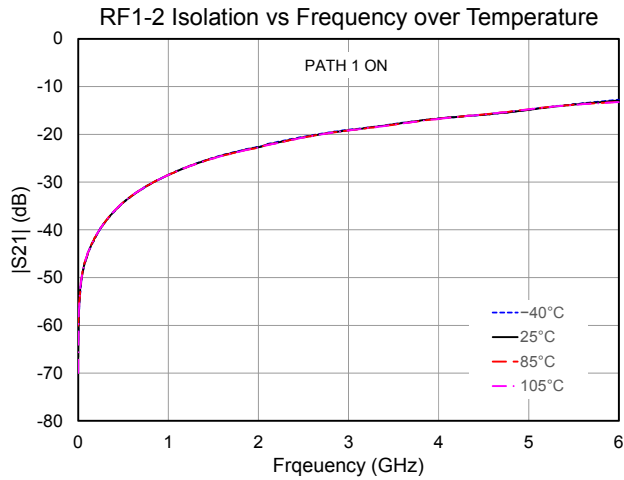
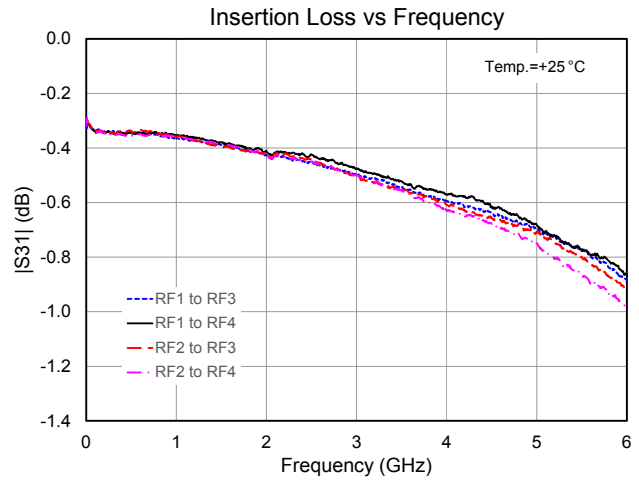
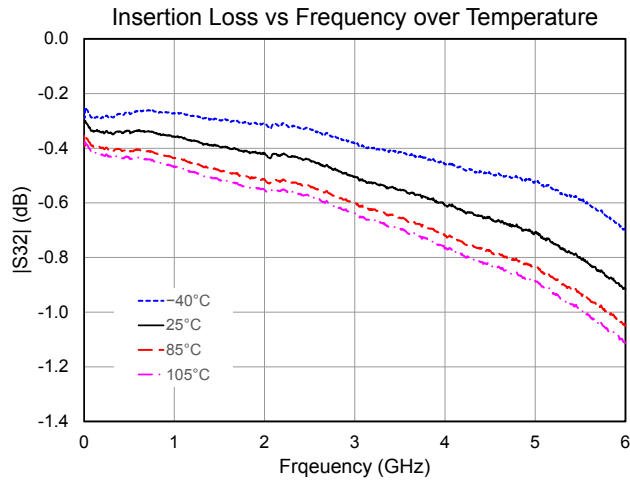

Performance Plots

Test conditions unless otherwise noted: $V_{DD} = +2.8V$

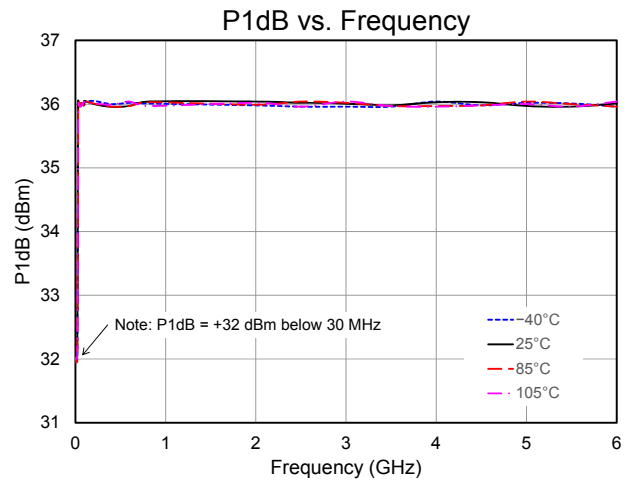
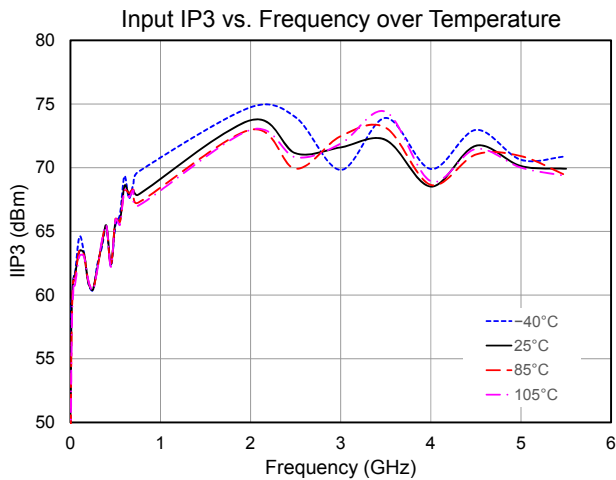
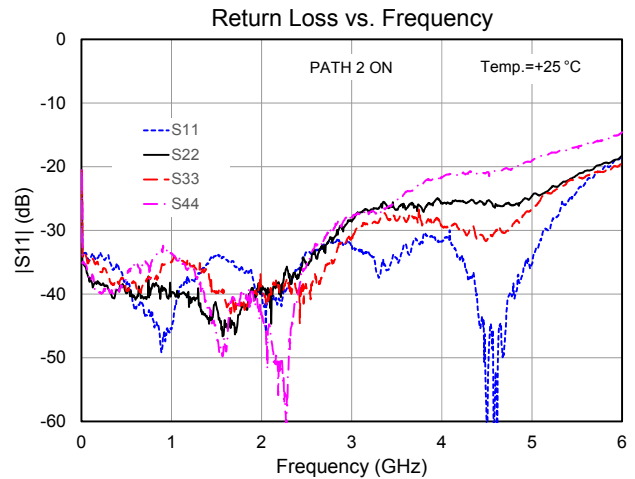
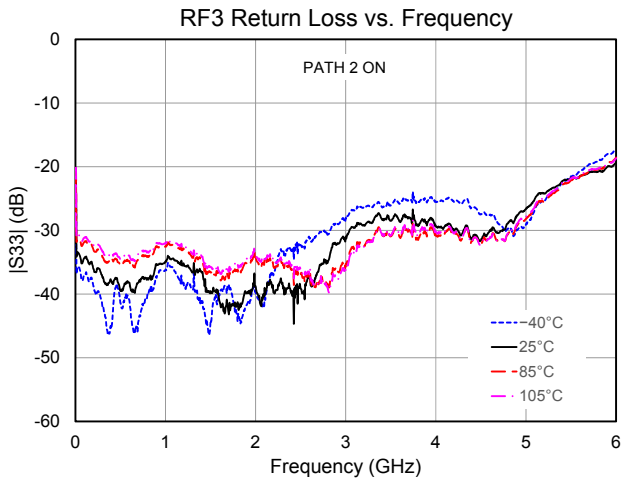
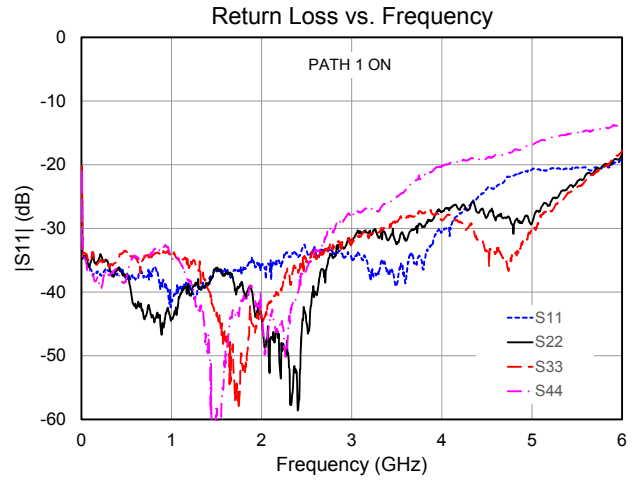
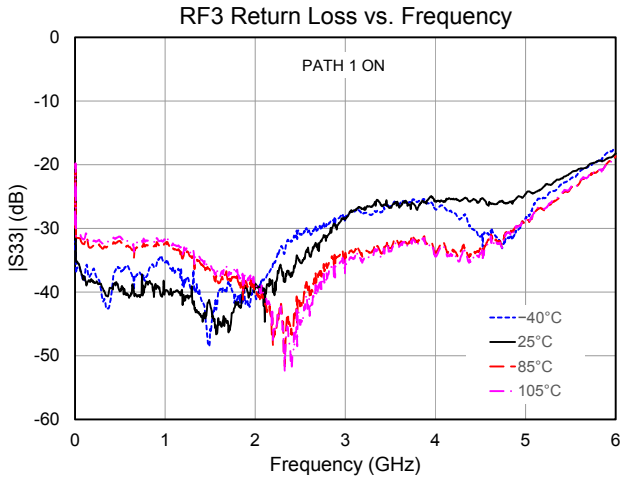

Evaluation Board Schematic

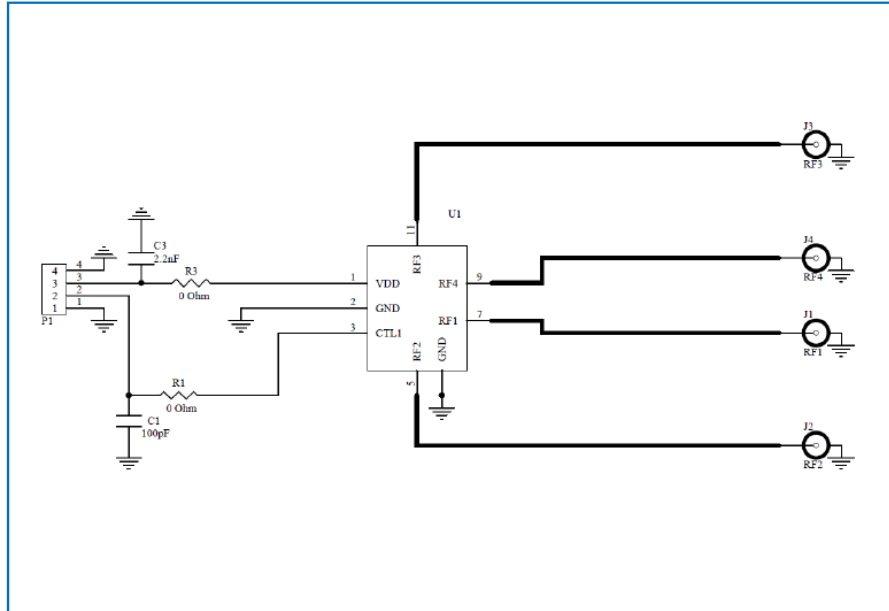

Evaluation Board Layout

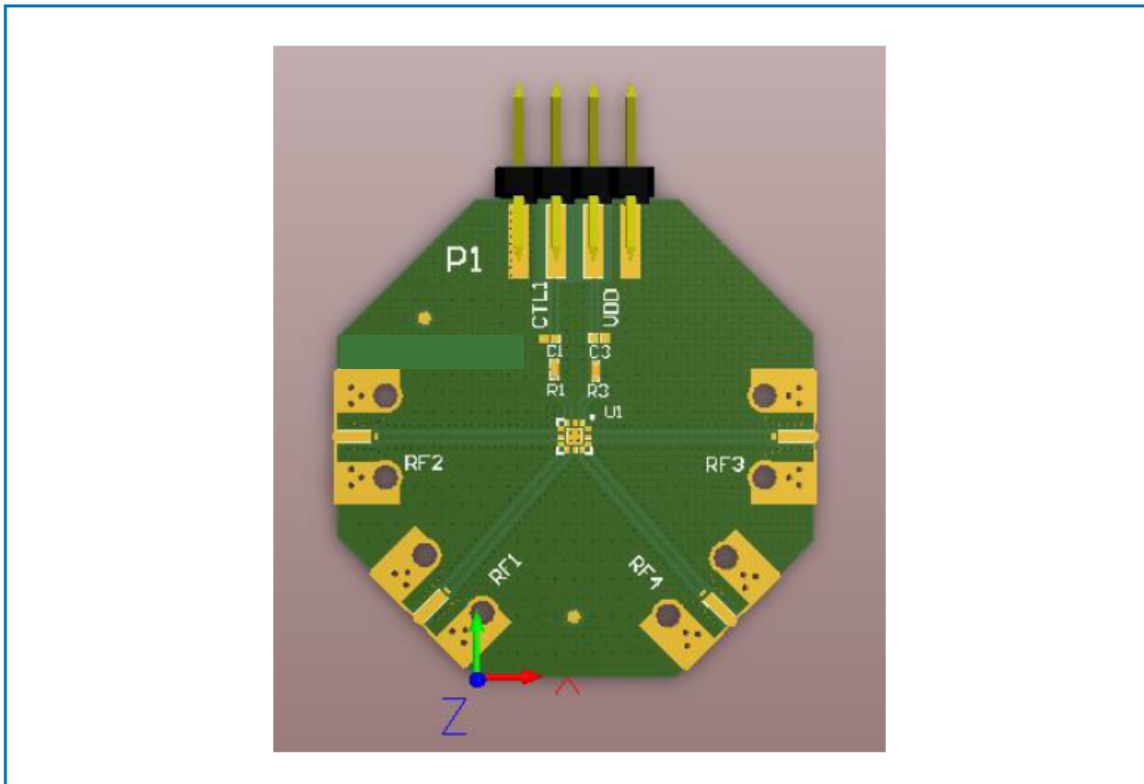

Pin Configuration and Description

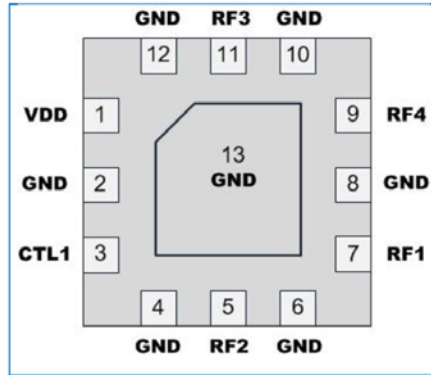

Pad No.	Label	Description
1	V _{DD}	Power Supply.
3	CTL1	Logic control pin 1.
5	RF2	RF Port connecting to either RF3 or RF4. Avoid applying DC voltage.
7	RF1	RF Port connecting to either RF3 or RF4. Avoid applying DC voltage.
9	RF4	RF Port connecting to either RF1 or RF2. Avoid applying DC voltage.
11	RF3	RF Port connecting to either RF1 or RF2. Avoid applying DC voltage.
2, 4, 6, 8, 10, 12, 13	GND	GND.

Package Marking and Dimensions

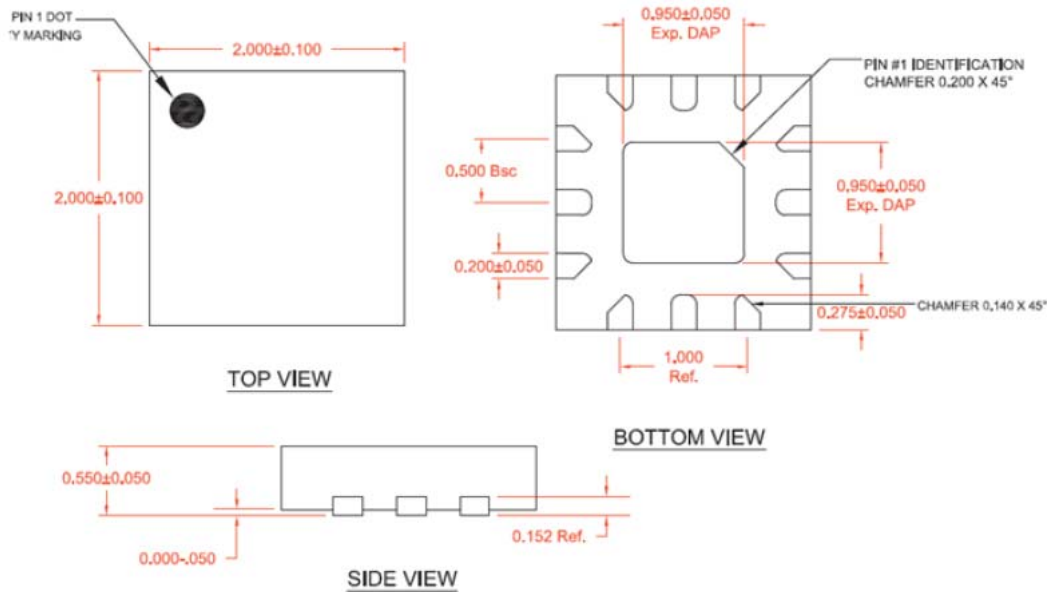

PCB Mounting Patterns

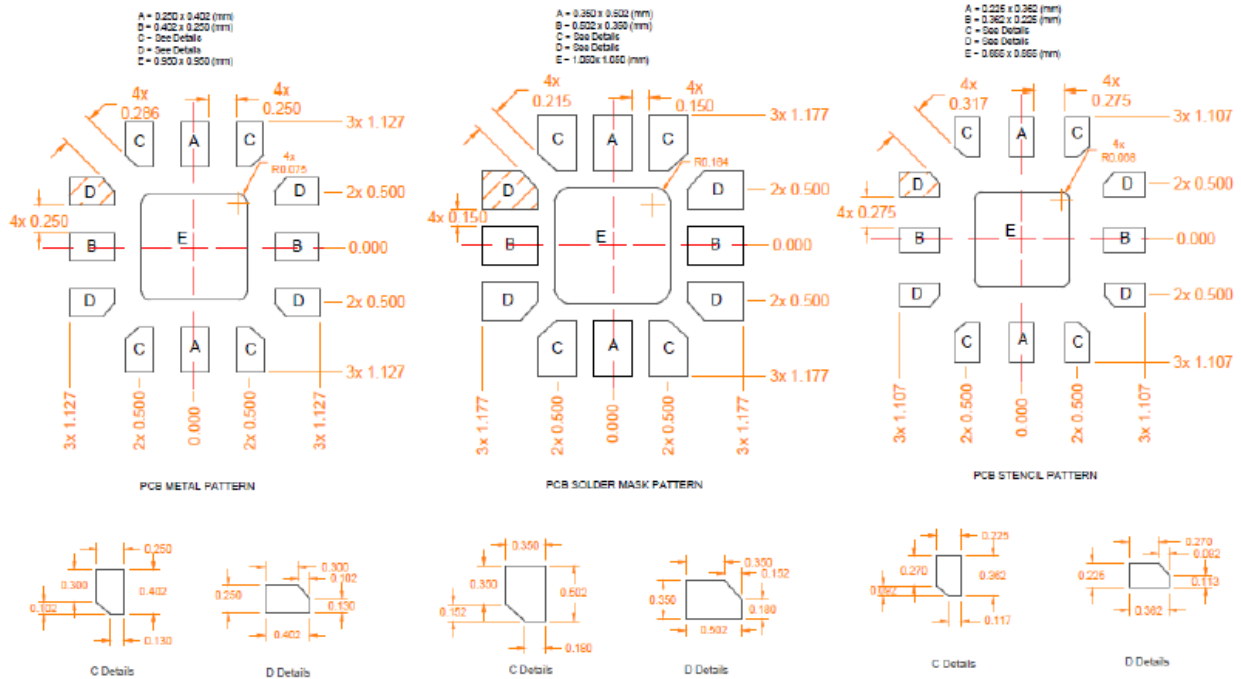

- Notes:
- Thermal vias for center slug "E" should be incorporated into the PCB design. The number and size of thermal vias will depend on the application, the power dissipation and the electrical requirements. An example of the number and size of the vias can be found on the Qorvo evaluation board layout.
 - Shaded pad in drawing above indicates pin 1 location.

Handling Precautions

Parameter	Rating	Standard
ESD – Human Body Model (HBM)	Class 2C	ESDA / JEDEC JS-001-2012
ESD – Charged Device Model (CDM)	Class C3	JEDEC JESD22-C101F
MSL – Moisture Sensitivity Level	MSL 1	IPC/JEDEC J-STD-020



Caution!
ESD-Sensitive Device

Solderability

Compatible with both lead-free (260°C max. reflow temp.) and tin/lead (245°C max. reflow temp.) soldering processes. Solder profiles available upon request.

Contact plating: NiPdAu

RoHS Compliance

This part is compliant with 2011/65/EU RoHS directive (Restrictions on the Use of Certain Hazardous Substances in Electrical and Electronic Equipment) as amended by Directive 2015/863/EU.

This product also has the following attributes:

- Lead Free
- Halogen Free (Chlorine, Bromine)
- Antimony Free
- TBBP-A (C₁₅H₁₂Br₄O₂) Free
- PFOS Free
- SVHC Free



Contact Information

For the latest specifications, additional product information, worldwide sales and distribution locations:

Web: www.qorvo.com

Tel: 1-844-890-8163

Email: customer.support@qorvo.com

Important Notice

The information contained herein is believed to be reliable; however, Qorvo makes no warranties regarding the information contained herein and assumes no responsibility or liability whatsoever for the use of the information contained herein. All information contained herein is subject to change without notice. Customers should obtain and verify the latest relevant information before placing orders for Qorvo products. The information contained herein or any use of such information does not grant, explicitly or implicitly, to any party any patent rights, licenses, or any other intellectual property rights, whether with regard to such information itself or anything described by such information. **THIS INFORMATION DOES NOT CONSTITUTE A WARRANTY WITH RESPECT TO THE PRODUCTS DESCRIBED HEREIN, AND QORVO HEREBY DISCLAIMS ANY AND ALL WARRANTIES WITH RESPECT TO SUCH PRODUCTS WHETHER EXPRESS OR IMPLIED BY LAW, COURSE OF DEALING, COURSE OF PERFORMANCE, USAGE OF TRADE OR OTHERWISE, INCLUDING THE IMPLIED WARRANTIES OF MERCHANTABILITY AND FITNESS FOR A PARTICULAR PURPOSE.**

Without limiting the generality of the foregoing, Qorvo products are not warranted or authorized for use as critical components in medical, life-saving, or life-sustaining applications, or other applications where a failure would reasonably be expected to cause severe personal injury or death.

Copyright 2016 © Qorvo, Inc. | Qorvo is a registered trademark of Qorvo, Inc.



Стандарт Электрон Связь

Мы молодая и активно развивающаяся компания в области поставок электронных компонентов. Мы поставляем электронные компоненты отечественного и импортного производства напрямую от производителей и с крупнейших складов мира.

Благодаря сотрудничеству с мировыми поставщиками мы осуществляем комплексные и плановые поставки широчайшего спектра электронных компонентов.

Собственная эффективная логистика и склад в обеспечивает надежную поставку продукции в точно указанные сроки по всей России.

Мы осуществляем техническую поддержку нашим клиентам и предпродажную проверку качества продукции. На все поставляемые продукты мы предоставляем гарантию .

Осуществляем поставки продукции под контролем ВП МО РФ на предприятия военно-промышленного комплекса России , а также работаем в рамках 275 ФЗ с открытием отдельных счетов в уполномоченном банке. Система менеджмента качества компании соответствует требованиям ГОСТ ISO 9001.

Минимальные сроки поставки, гибкие цены, неограниченный ассортимент и индивидуальный подход к клиентам являются основой для выстраивания долгосрочного и эффективного сотрудничества с предприятиями радиоэлектронной промышленности, предприятиями ВПК и научно-исследовательскими институтами России.

С нами вы становитесь еще успешнее!

Наши контакты:

Телефон: +7 812 627 14 35

Электронная почта: sales@st-electron.ru

Адрес: 198099, Санкт-Петербург,
Промышленная ул, дом № 19, литера Н,
помещение 100-Н Офис 331