

STK521

.....
User Guide



Table of Contents

Section 1 1

Introduction 1

Features 2

Section 2 3

Using the STK521 Top Module 3

Connecting the Atmel STK521 to the Atmel STK500 Starter Kit 3

Powering the STK521 4

Programming the AVR 5

Atmel AVR JTAGICE mkII Connector 7

Atmel STK521 switches configuration 9

Atmel STK521 headers 10

Atmel STK521 test points 11

Extra functions 11

Section 3 12

Troubleshooting Guide 12

Section 4 13

Technical Specifications 13

Section 5 14

Technical Support 14

Section 6 15

Complete Schematics 15

Introduction

The Atmel® AVR® STK®521 kit is made of the Atmel AVR STK521 board.

The STK521 board is a top module for the Atmel STK500 development board from Atmel Corporation. It is designed to support the Atmel AT90PWM81, Atmel AT90PWM161 products and future compatible derivatives.

The STK521 includes connectors and hardware allowing full utilization of the new features of the AT90PWM81/161, while the Zero Insertion Force (ZIF) socket allows easy to use of SOIC20 package for prototyping.

This user guide acts as a general getting started guide as well as a complete technical reference for advanced users.

Note that in this guide, the word AVR is used to refer to the target components (AT90PWM81/161). AT90PWM81 will be also used to refer to one of the products from this family.

Figure 1-1. STK521 Top Module for STK500.

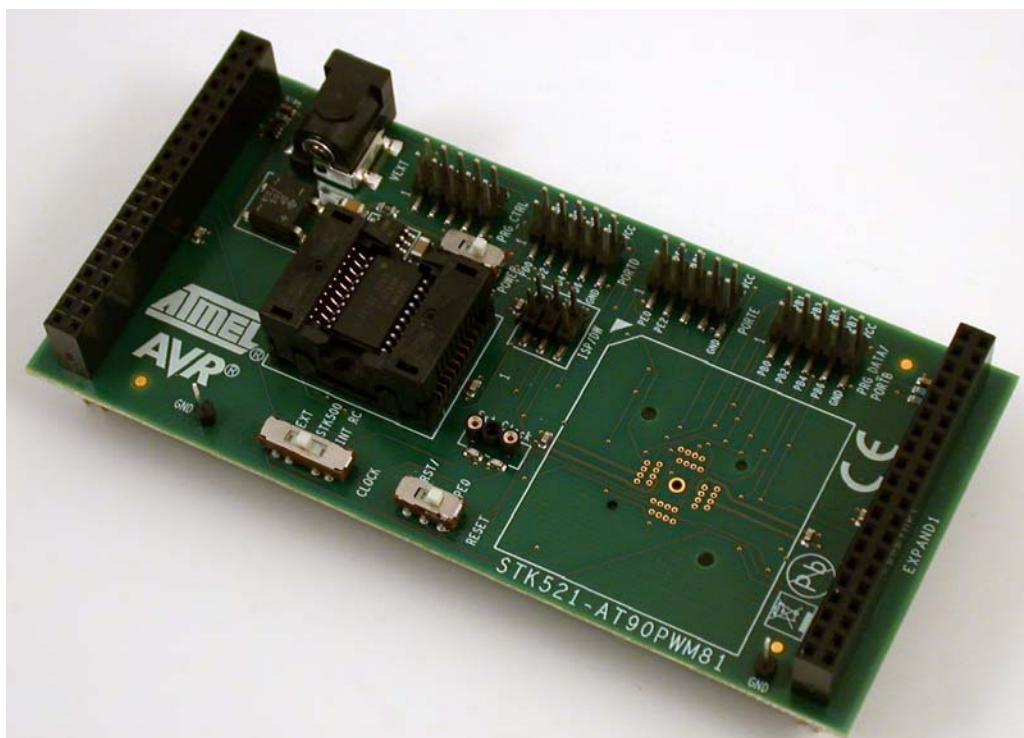

1.1 Features

- Atmel AVR STK521 is a new member of the successful Atmel STK500 starter kit family
- Supports the Atmel AT90PWM81, Atmel AT90PWM161
- Supported by Atmel AVR Studio® 4.15 or above and Atmel AVR Studio 5.1
- Zero Insertion Force Socket for SOIC20 Package
- Zero Insertion Force Socket for QFN32 Package (not populated)
- High Voltage Parallel Programming
- Serial Programming
- 6-pin Connector for On-chip Debugging using Atmel AVR JTAGICE mkII or Atmel AVR Dragon™ emulators
- Switches for Reset/GPIOs configuration, Xtal/GPIOs or power supply configuration
- External power supply connector for standalone mode
- Quick Reference to all Jumpers in the Silk-Screen of the PCB

Using the STK521 Top Module

2.1 Connecting the Atmel STK521 to the Atmel STK500 Starter Kit

Connect the STK521 to the STK500 expansion header 0 and 1. It is important that the top module is connected in the correct orientation as shown in [Figure 2-1](#). The EXPAND0 written on the STK521 top module should match the EXPAND0 written beside the expansion header on the STK500 board.

Figure 2-1. Connecting STK521 to the STK500 Board.

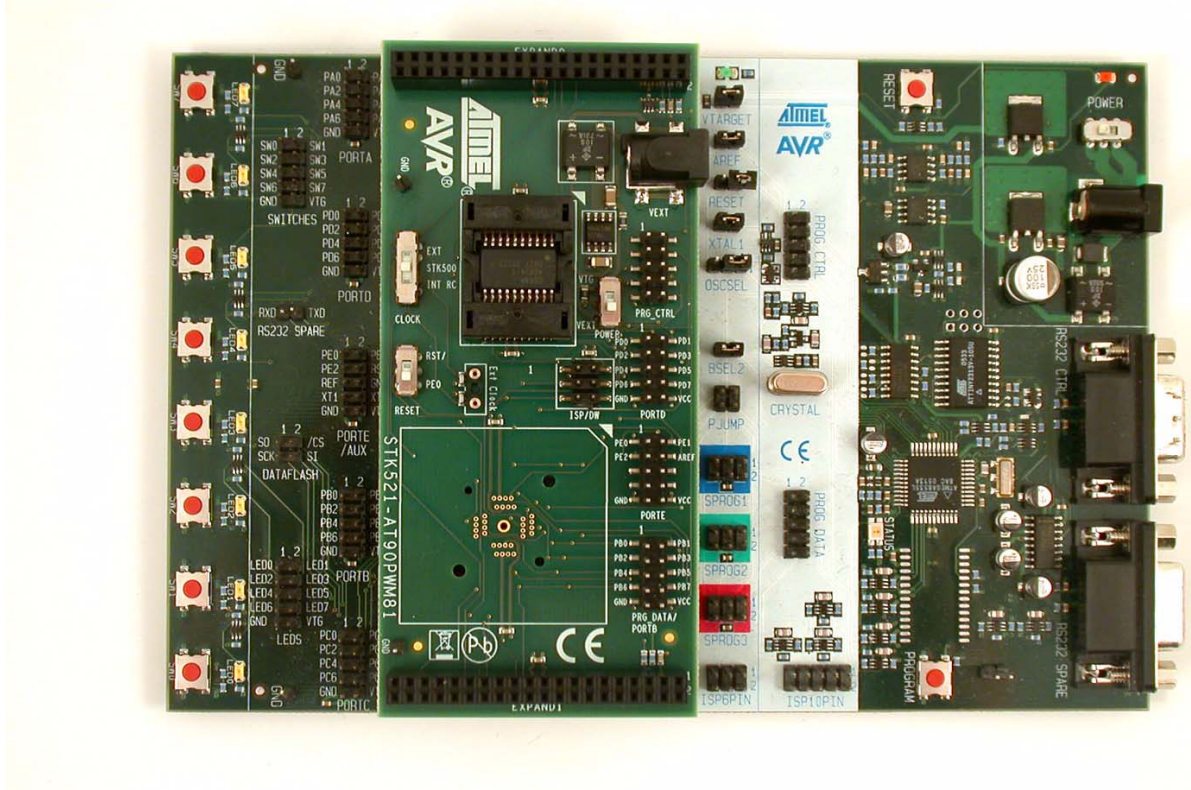

Note: Connecting the STK521 with wrong orientation may damage the board.

2.1.1 Placing an Atmel AT90PWM81 on the Atmel STK521

The STK521 contains a ZIF socket for a SOIC20 package. Care should be taken so that the device is mounted with the correct orientation. [Figure 2-2](#) shows the location of pin1 for the ZIF socket.

Figure 2-2. Pin1 on ZIF Socket.

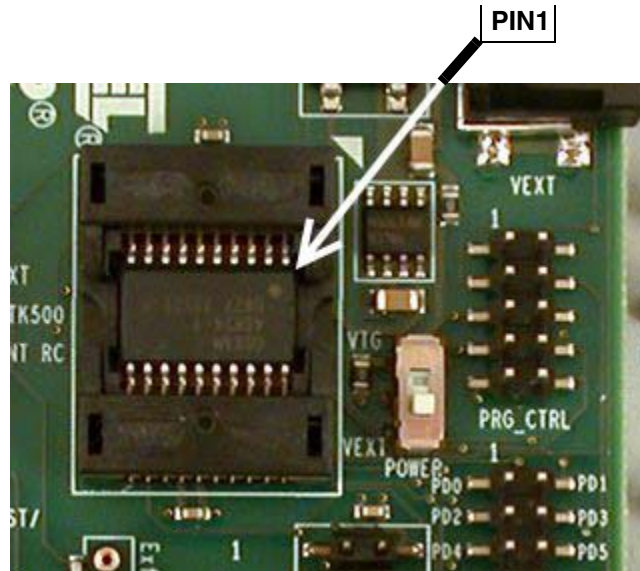

Caution: Do not mount an Atmel AT90PWM81 on the STK521 at the same time as an AVR is mounted on the STK500 board. None of the devices might work as intended.

2.2 Powering the STK521

The STK521 can be powered as follows :

1. Through the STK500 by selecting POWER switch to VTG.
2. Through an external power supply using the jack connector and selecting POWER switch to VEXT.

In this latter case, power supply must be 10V DC for a 5V device power supply.

2.3 Programming the AVR

The Atmel AT90PWM81 can be programmed using both serial SPI and high-voltage parallel programming. This section will explain how to connect the programming cables to successfully use one of these two modes. The Atmel AVR Studio STK500 software is used in the same way as for other AVR parts.

Note: The AT90PWM81 also supports Self Programming, see the Atmel AVR109 application note for more information on this topic.

2.3.1 Serial in-system programming

Figure 2-3. Serial in-system programming.

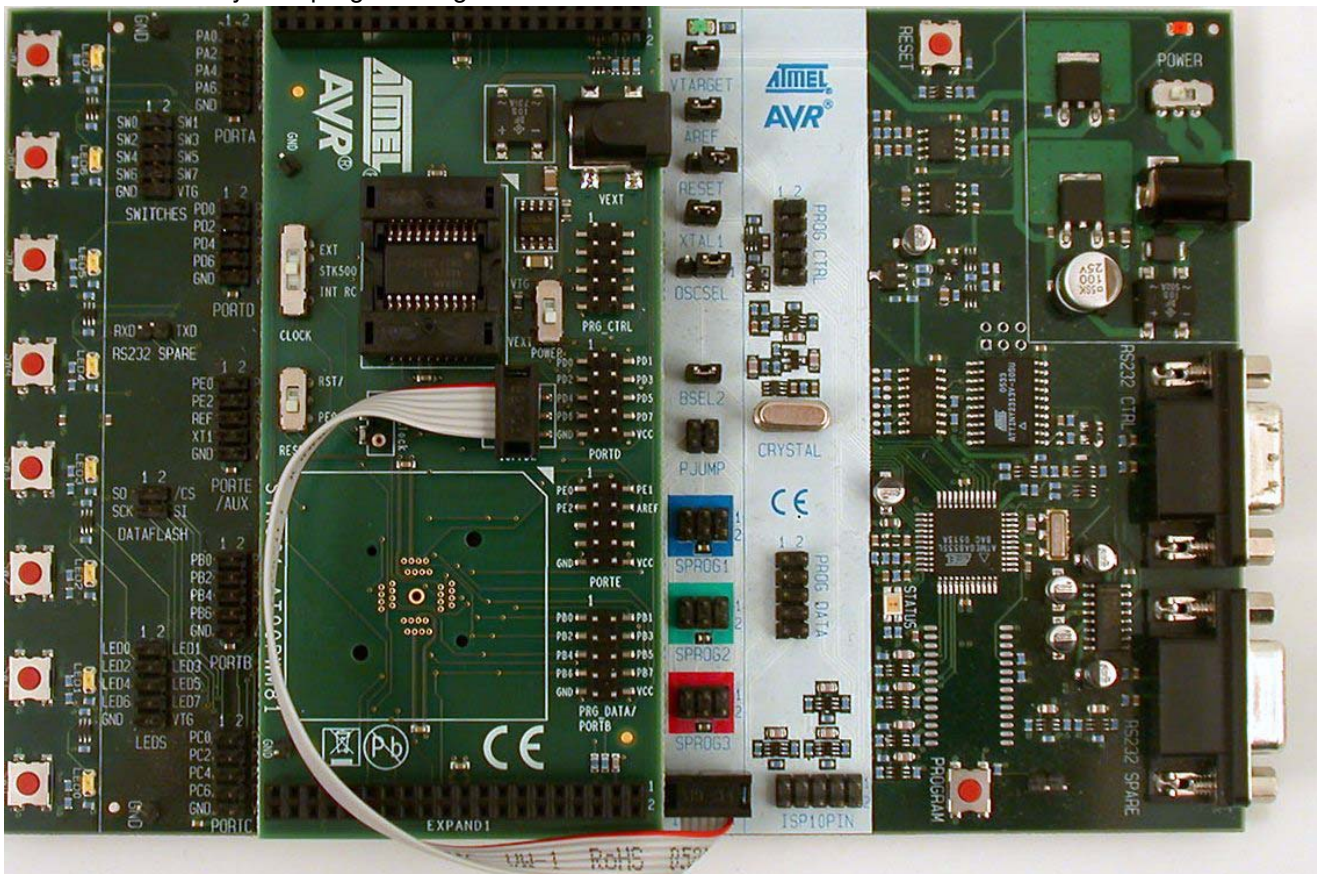

To program the AT90PWM81 using ISP programming mode, connect the 6-wire cable between the ISP6PIN connector on the Atmel STK500 board and the ISP connector on the Atmel STK521 board as shown in [Figure 2-3](#). The device can be programmed using the Serial Programming mode in the AVR Studio 4 STK500 software.

The Atmel STK500 and STK521 jumpers must be configured as follows :

Table 2-1. In-System programming jumper settings for the Atmel AT90PWM81.

STK500	
VTARGET	Mounted
AREF	Open
RESET	Open
XTAL1	Mounted
OSCSEL	Mounted, pin 1 and 2
BSEL2	Open
PJUMP	Open

Note: See the Atmel STK500 User Guide for information on how to use the STK500 front-end software for ISP Programming.

2.3.2 High-voltage programming

Figure 2-4. High-voltage (parallel) programming.

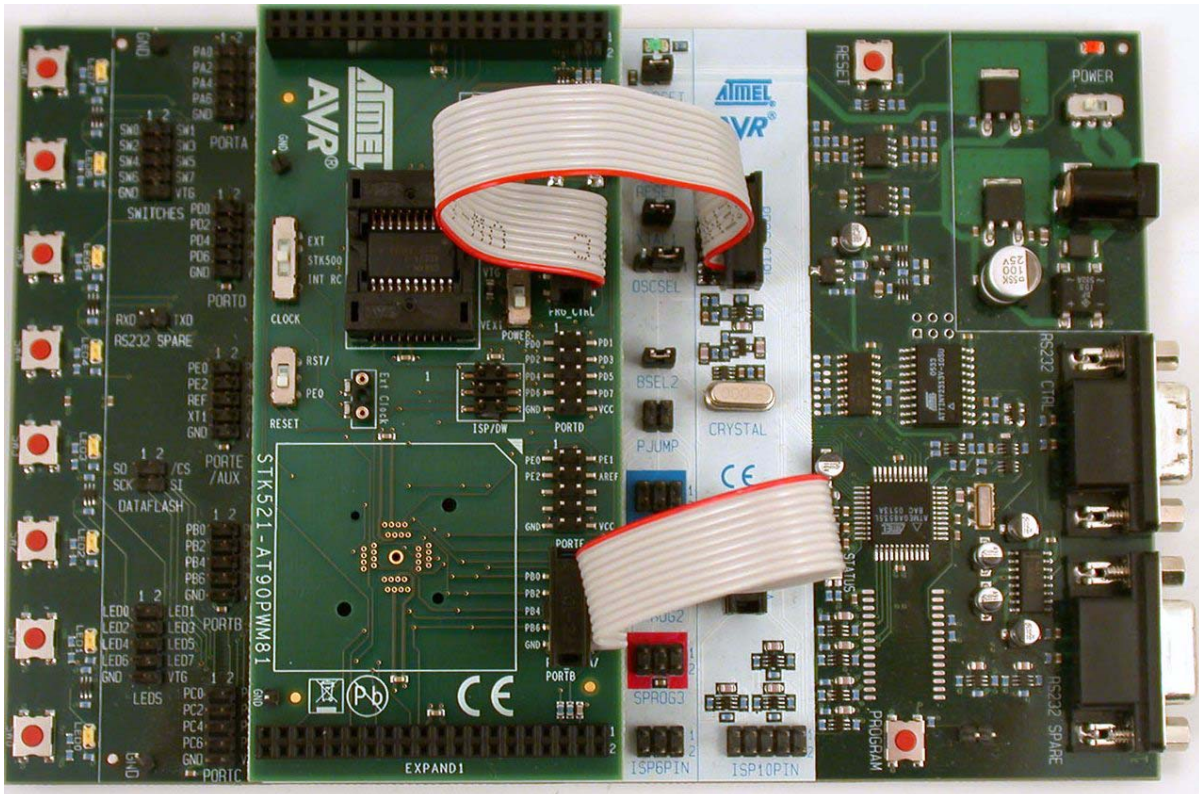

To program the AVR using high-voltage (parallel) programming, connect the PROG_CTRL of the Atmel STK500 to PRG_CTRL of the Atmel STK521 and PROG_DATA of STK500 to PRG_DATA of STK521 as shown in [Figure 2-4](#). Make sure that the CLOCK switch is placed in the STK500 position.

The STK500 and STK521 jumpers & switches must be configured as follows :

Table 2-2. High-Voltage programming jumper settings for the Atmel AT90PWM81.

STK500	
VTARGET	Mounted
AREF	Open
RESET	Mounted
XTAL1	Mounted
OSCSEL	Mounted, pin 1 and 2
BSEL2	Mounted
PJUMP	Open

Table 2-3. High-voltage programming switches settings for AT90PWM81.

STK521	
POWER	VTG
CLOCK	STK500
RESET	RST/

The device can now be programmed using the high-voltage programming mode in the Atmel AVR Studio STK500 software.

Note: See the Atmel STK500 User Guide for information on how to use the STK500 front-end software in high-voltage programming mode.

For the high-voltage programming mode to function correctly, the target voltage must be higher than 4.5V.

2.4 Atmel AVR JTAGICE mkII Connector

See the following document :

“JTAGICE mkII Quick Start Guide” which purpose is “Connecting to a target board with the AVR JTAGICE mkII”.

This note explains which signals are required for ISP and which signals are required for debugWIRE.

[Figure 2-5](#) shows how to connect the Atmel AVR JTAGICE mkII probe on the STK521 board.

Figure 2-5. Connecting the Atmel AVR JTAGICE mkII to the Atmel STK521.

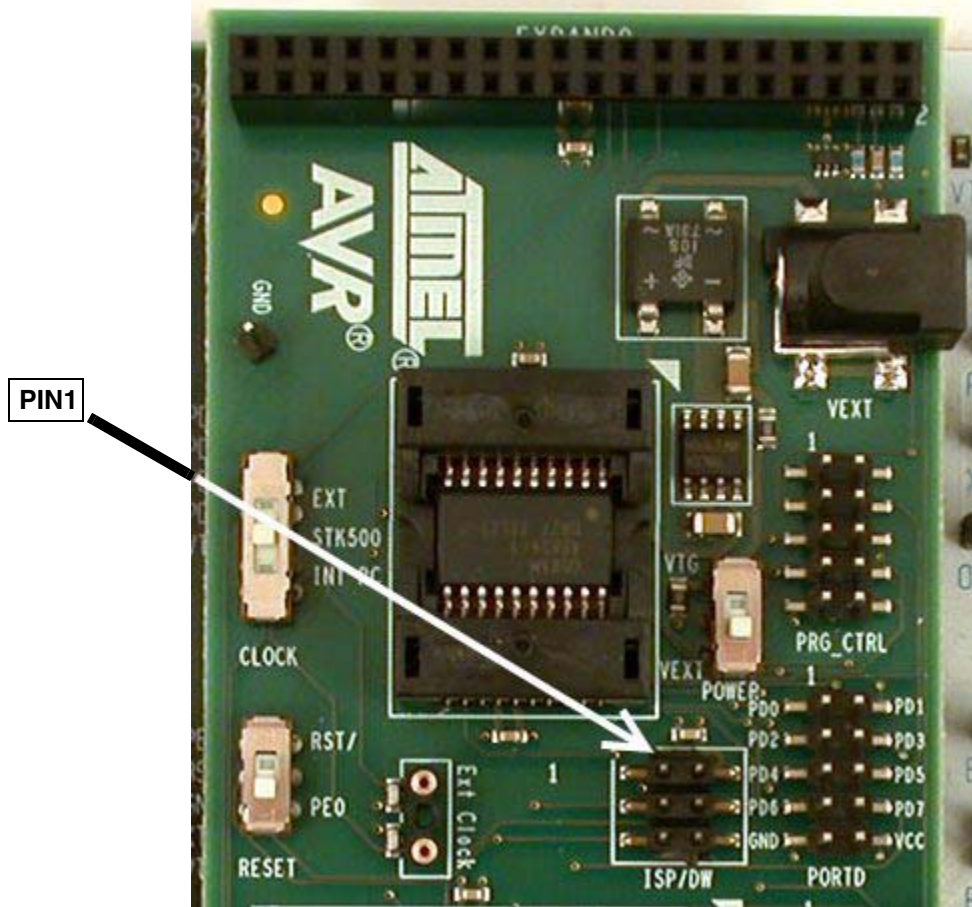

The ISP connector is used for the Atmel AT90PWM81 built-in debugWire interface. The pin out of the connector is shown in Table 2-4 and is compliant with the pin out of the JTAG ICE available from Atmel. Connecting a JTAGICE mkII to this connector allows on-chip debugging of the AT90PWM81.

More information about the JTAGICE mkII and on-chip debugging can be found in the Atmel AVR JTAGICE mkII User Guide, which is available at the Atmel web site, www.atmel.com.

Note: Remove the RESET jumper on the Atmel STK500 to work run properly JTAGICE mkII.

Table 2-4. STK521 ISP/DW connector pinout.

Squid cable colors	Target pins	STK521 ISP pinout		Target pins	Squid cable colors
grey	MISO	1	2	VTG	purple
black	SCK	3	4	MOSI	red
green	RESET	5	6	GND	brown

Note: MISO, MOSI, and SCK lines can be disconnected when the product is in debugging mode. They can then be used for application purpose.

2.5 Atmel STK521 switches configuration

The switches shown in [Figure 2-6](#) are described in [Table 2-5](#) .

Figure 2-6. STK521 switches.

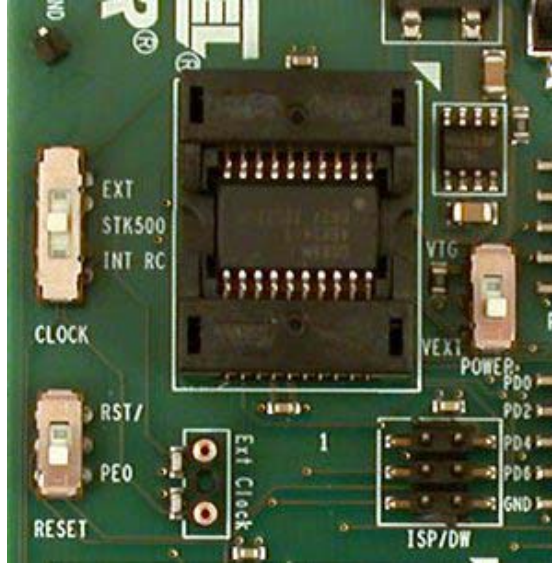

Table 2-5. STK521 switches description.

Switches	Function	Description
CLOCK	Clock source selection	EXT: clock from crystal plugged in Ext Clock socket STK500: clock from Atmel STK500 INT RC: clock from internal RC oscillator
RESET	Reset pin configuration	RST/: Product reset pin is connected to STK500 reset button PE0: Product reset pin is connected to PE0 on PORTE header
POWER	Power supply source selection	VEXT: External power supply through power jack VTG: STK500 power supply through expansion header

2.6 Atmel STK521 headers

Headers are populated for both high voltage programming purpose as well as for port connection to LEDs or switches.

Figure 2-7. STK521 port headers.

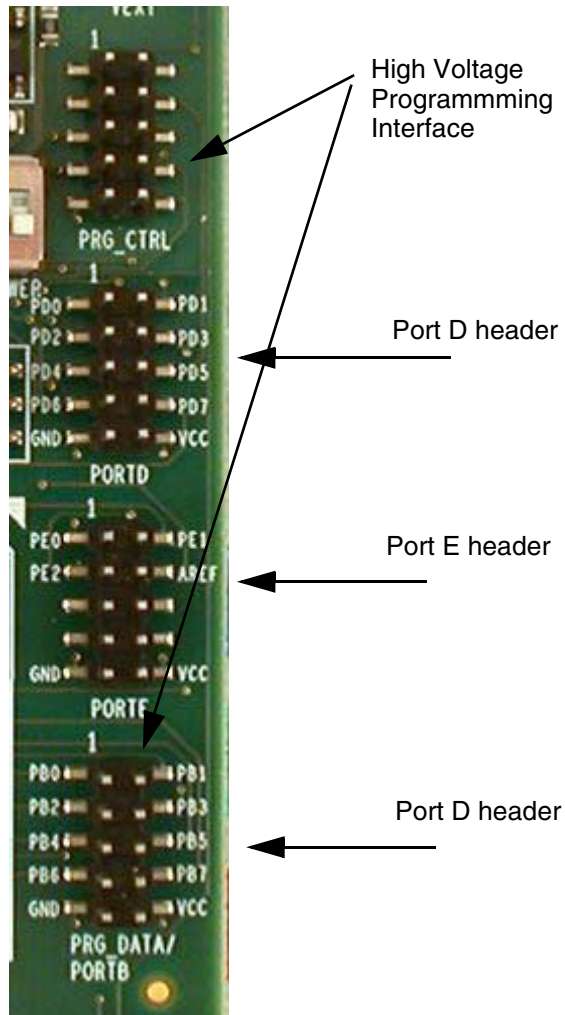

2.7 Atmel STK521 test points

Table 2-6. STK521 test points.

Test Point	Function	Description
T1	GND	GND test point
T2	GND	GND test point

These are placed on both right and left side of the board for probes.

2.8 Extra functions

The STK521 includes a footprint for a ZIF QFN32 5x5 mm socket to evaluate QFN32 package. The socket is not mounted but can be populated using the PN : QFN32(40)BT-0.5-02 from Enplas.



Section 3

Troubleshooting Guide

Table 3-1. Troubleshooting guide.

Problem	Reason	Solution
Unable to do ISP and high-voltage programming using Internal 1MHz RC oscillator	Usage of internal 1MHz RC oscillator not recommended	To start the microcontroller in low power mode, use the 128KHz oscillator



Section 4

Technical Specifications

System unit

Physical dimensions 56mm x 119mm x 27mm

Weight 70g

Operating conditions

Voltage supply 1.8V - 5.5V

Temperature 0°C - 50°C



Section 5

Technical Support

For technical support, please contact avr@atmel.com. When requesting technical support, please include the following information:

- Which target AVR device is used (complete part number)
- Target voltage and speed
- Clock source and fuse setting of the AVR
- Programming method (ISP or high-voltage)
- Hardware revisions of the AVR tools, found on the PCB
- Version number of the Atmel AVR Studio. This can be found in the AVR Studio help menu
- PC operating system and version/build
- PC processor type and speed
- A detailed description of the problem



Section 6

Complete Schematics

On the following pages the complete schematics and assembly drawing of the Atmel STK521 revision B are shown.

Figure 6-1. Schematics, 1 of 3.

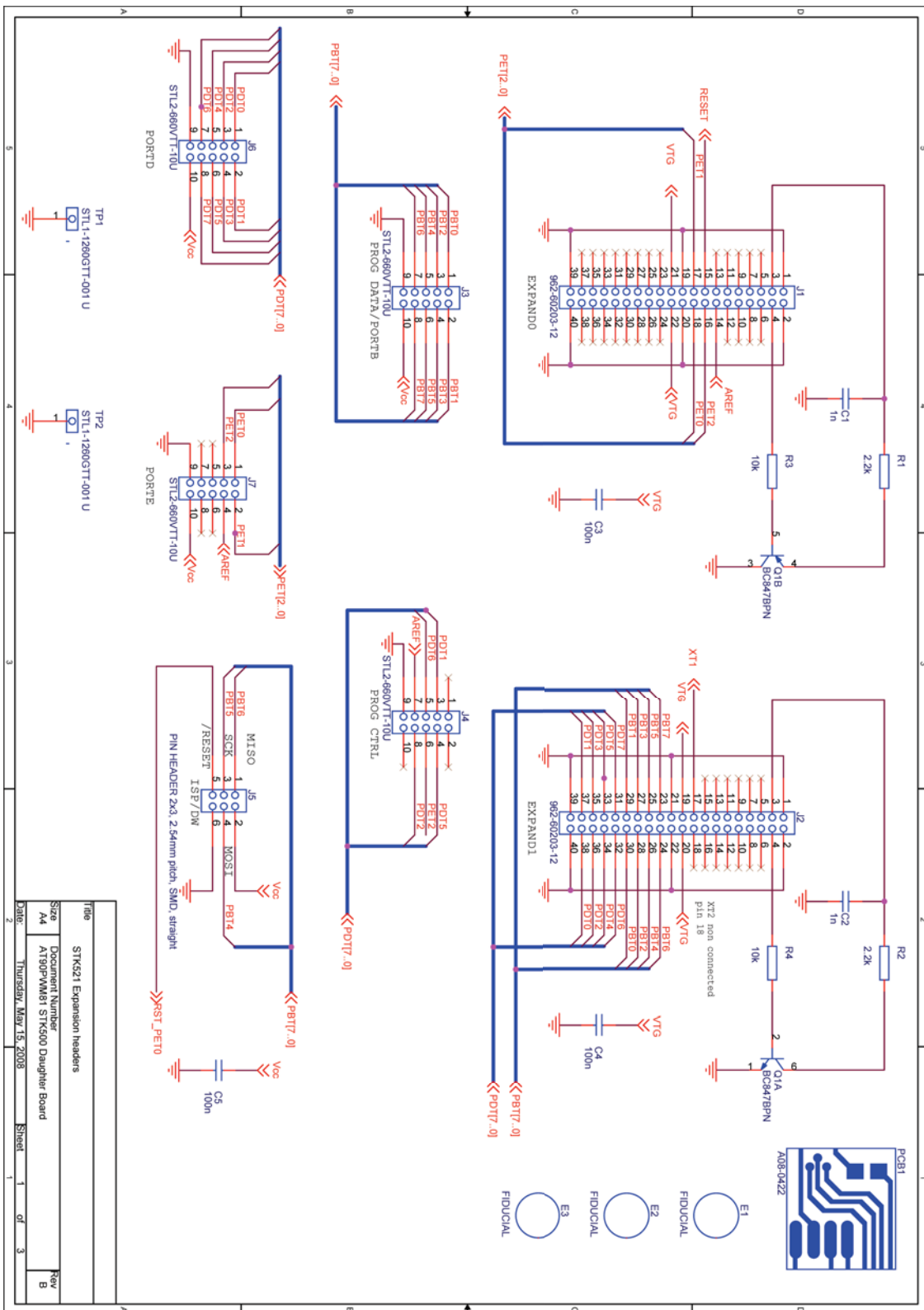

Figure 6-2. Schematics, 2 of 3.

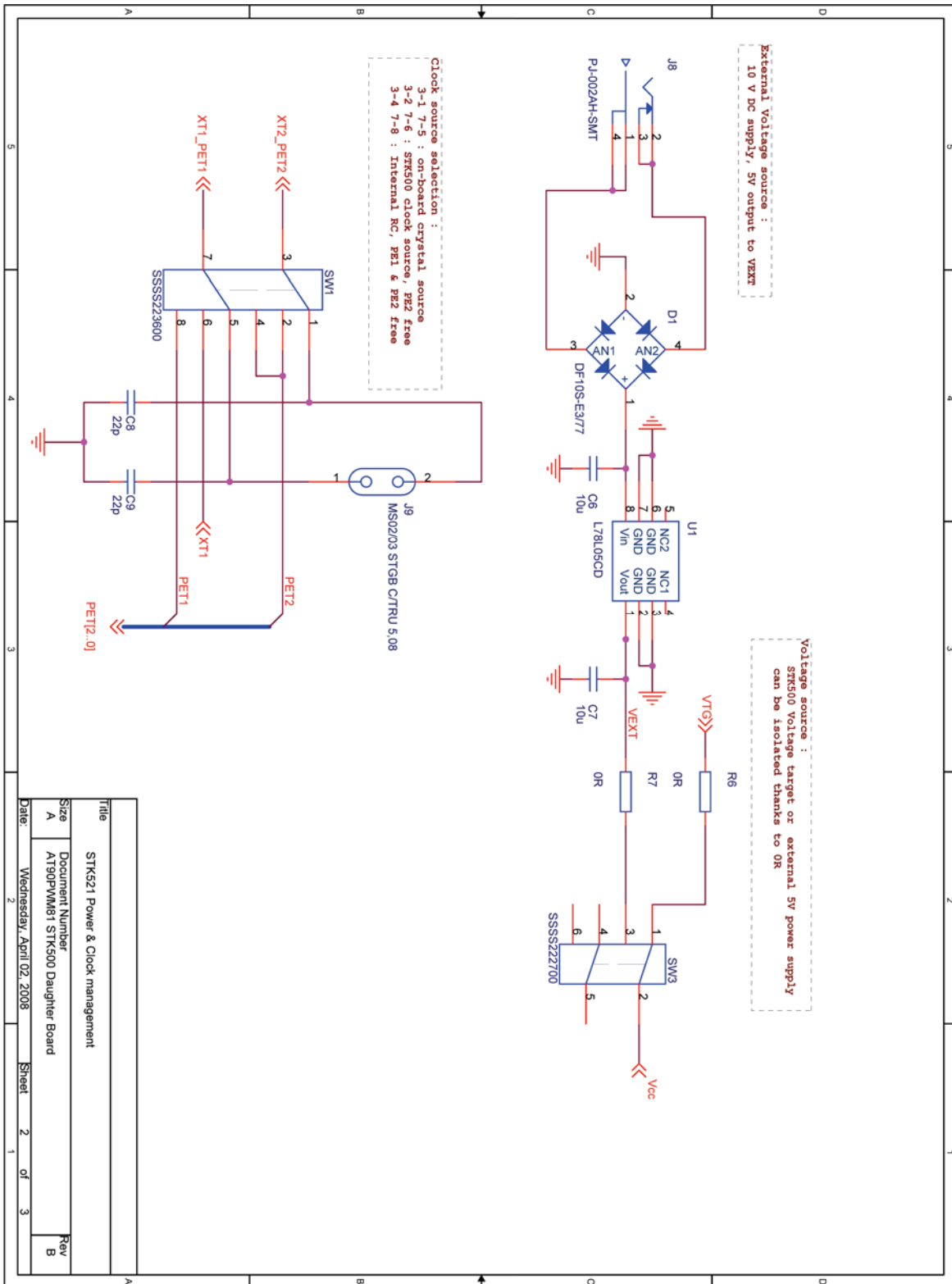

Figure 6-3. Schematics, 3 of 3.

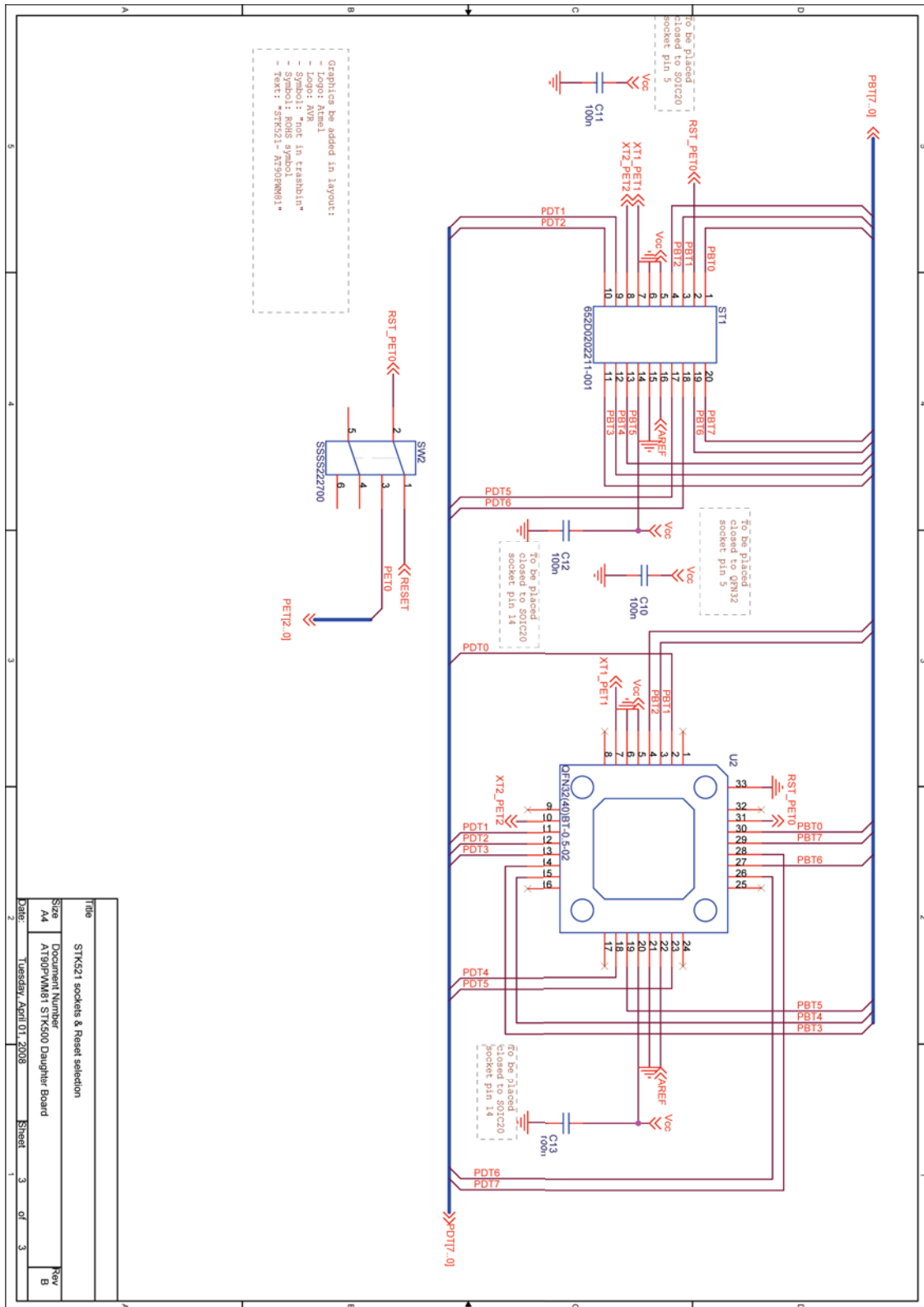
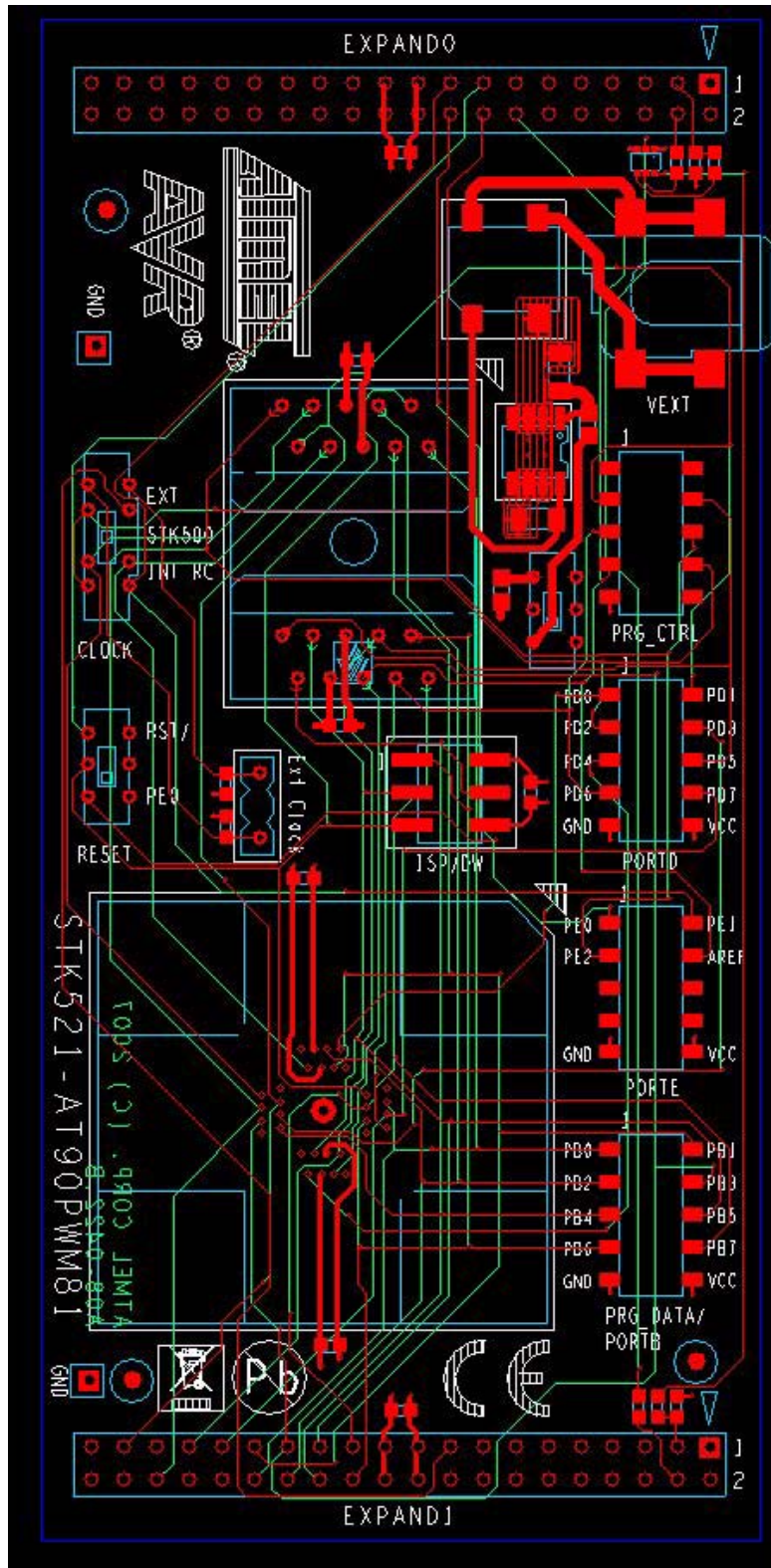

Figure 6-4. Assembly drawing, 1 of 1.



**Atmel Corporation**

2325 Orchard Parkway
San Jose, CA 95131
USA

Tel: (+1)(408) 441-0311

Fax: (+1)(408) 487-2600

www.atmel.com

Atmel Asia Limited

Unit 1-5 & 16, 19/F
BEA Tower, Millennium City 5
418 Kwun Tong Road
Kwun Tong, Kowloon

HONG KONG

Tel: (+852) 2245-6100

Fax: (+852) 2722-1369

Atmel Munich GmbH

Business Campus
Parkring 4
D-85748 Garching b. Munich
GERMANY

Tel: (+49) 89-31970-0

Fax: (+49) 89-3194621

Atmel Japan

16F, Shin Osaki Kangyo Bldg.
1-6-4 Osaki Shinagawa-ku
Tokyo 104-0032

JAPAN

Tel: (+81) 3-6417-0300

Fax: (+81) 3-6417-0370

© 2012 Atmel Corporation. All rights reserved.

Atmel®, Atmel logo and combinations thereof, AVR®, AVR Studio®, STK®, and others are registered trademarks or trademarks of Atmel Corporation or its subsidiaries. Other terms and product names may be trademarks of others.

Disclaimer: The information in this document is provided in connection with Atmel products. No license, express or implied, by estoppel or otherwise, to any intellectual property right is granted by this document or in connection with the sale of Atmel products. **EXCEPT AS SET FORTH IN THE ATMEL TERMS AND CONDITIONS OF SALES LOCATED ON THE ATMEL WEBSITE, ATMEL ASSUMES NO LIABILITY WHATSOEVER AND DISCLAIMS ANY EXPRESS, IMPLIED OR STATUTORY WARRANTY RELATING TO ITS PRODUCTS INCLUDING, BUT NOT LIMITED TO, THE IMPLIED WARRANTY OF MERCHANTABILITY, FITNESS FOR A PARTICULAR PURPOSE, OR NON-INFRINGEMENT. IN NO EVENT SHALL ATMEL BE LIABLE FOR ANY DIRECT, INDIRECT, CONSEQUENTIAL, PUNITIVE, SPECIAL OR INCIDENTAL DAMAGES (INCLUDING, WITHOUT LIMITATION, DAMAGES FOR LOSS AND PROFITS, BUSINESS INTERRUPTION, OR LOSS OF INFORMATION) ARISING OUT OF THE USE OR INABILITY TO USE THIS DOCUMENT, EVEN IF ATMEL HAS BEEN ADVISED OF THE POSSIBILITY OF SUCH DAMAGES.** Atmel makes no representations or warranties with respect to the accuracy or completeness of the contents of this document and reserves the right to make changes to specifications and product descriptions at any time without notice. Atmel does not make any commitment to update the information contained herein. Unless specifically provided otherwise, Atmel products are not suitable for, and shall not be used in, automotive applications. Atmel products are not intended, authorized, or warranted for use as components in applications intended to support or sustain life.

Mouser Electronics

Authorized Distributor

Click to View Pricing, Inventory, Delivery & Lifecycle Information:

[Microchip:](#)

[ATSTK521](#)



Стандарт Электрон Связь

Мы молодая и активно развивающаяся компания в области поставок электронных компонентов. Мы поставляем электронные компоненты отечественного и импортного производства напрямую от производителей и с крупнейших складов мира.

Благодаря сотрудничеству с мировыми поставщиками мы осуществляем комплексные и плановые поставки широчайшего спектра электронных компонентов.

Собственная эффективная логистика и склад в обеспечивает надежную поставку продукции в точно указанные сроки по всей России.

Мы осуществляем техническую поддержку нашим клиентам и предпродажную проверку качества продукции. На все поставляемые продукты мы предоставляем гарантию .

Осуществляем поставки продукции под контролем ВП МО РФ на предприятия военно-промышленного комплекса России , а также работаем в рамках 275 ФЗ с открытием отдельных счетов в уполномоченном банке. Система менеджмента качества компании соответствует требованиям ГОСТ ISO 9001.

Минимальные сроки поставки, гибкие цены, неограниченный ассортимент и индивидуальный подход к клиентам являются основой для выстраивания долгосрочного и эффективного сотрудничества с предприятиями радиоэлектронной промышленности, предприятиями ВПК и научно-исследовательскими институтами России.

С нами вы становитесь еще успешнее!

Наши контакты:

Телефон: +7 812 627 14 35

Электронная почта: sales@st-electron.ru

Адрес: 198099, Санкт-Петербург,
Промышленная ул, дом № 19, литера Н,
помещение 100-Н Офис 331