

## PIC32-MAXI-WEB development board Users Manual



All boards produced by Olimex are RoHS compliant

Rev. A, February 2011

Copyright(c) 2011, OLIMEX Ltd, All rights reserved

## **INTRODUCTION:**

This board features a PIC32 processor with embedded 100Mbit Ethernet module allows you to easily develop Ethernet connectivity applications. It has everything you normally would need for such applications: power relays which you can command through web interface, a large 240x320 TFT LCD with touchscreen support that allows you to develop complex graphical user interface applications, digital optoisolated inputs, trimmer potentiometer, accelerometer with integrated temperature sensor, two CAN interface channels, RS232 interface, USB on-the-go and micro SD card slot to store large amounts of data. With this board you can easily automate your home and then control and monitor it from any point in the world via Internet. An extension connector is available so you can connect custom made hardware to the board. The PIC32MX795F512L has 512K Flash memory (plus an additional 12 KB of Boot Flash).

## **BOARD FEATURES:**

- PIC32MX795F512L High-Performance, USB, CAN and Ethernet 32-bit Flash Microcontroller
- TFT LCD 320x240 65 k colours with resistive touchscreen
- Debug interface - JTAG and ICSP
- RESET circuit
- Reset button
- Two optoisolated digital inputs with indicator LEDs
- Two CAN interfaces
- 100Mbit Ethernet interface
- Two UEXT connectors to connect to other Olimex boards
- Accelerometer with integrated temperature sensor
- micro SD card holder
- Two Relays 10A/250VAC with indicator LEDs
- USB\_OTG
- RS232 interface
- Trimmer connected to analogue input
- Three user LEDs
- PWR LED
- Three user buttons
- 3.3V voltage regulator
- Dimensions 140x100 mm (5.51x3.94")

## **ELECTROSTATIC WARNING:**

The PIC32-MAXI-WEB board is shipped in protective anti-static packaging. The board must not be subject to high electrostatic potentials. General practice for working with static sensitive devices should be applied when working with this board.

## **BOARD USE REQUIREMENTS:**

**Cables:** The Board needs external power supply cable and mini ICSP cable (connected to the respective debugger) in order to test basic functionality. Depending on the peripherals used you may also need and Ethernet RJ45 terminated cable, 9pin RS232 cable, miniUSB cable.

**Hardware:** The board requires +12V regulated power supply.

!!! Please note that the processor on this board is not supported by the once famous ICD2 programmer/debugger and derivatives, but by the PIC-KIT3 and other compatible tools.

**Software:** PIC32-MAXI-WEB is tested with MPLAB IDE v8.63 + MPLAB C32 v1.10B C compiler. It is possible that the demo application may not work as expected as new releases of MPLAB and the C32 compiler are released in the future.

## MICROCONTROLLER FEATURES:

**PIC32-MAXI-WEB** board use MCU **PIC32MX795F512L** from Microchip Technology with these features:

### **High-Performance 32-bit RISC CPU:**

- MIPS32® M4K® 32-bit core with 5-stage pipeline
- 80 MHz maximum frequency
- 1.56 DMIPS/MHz (Dhrystone 2.1) performance at zero Wait state Flash access
- Single-cycle multiply and high-performance divide unit
- MIPS16e™ mode for up to 40% smaller code size
- Two sets of 32 core register files (32-bit) to reduce interrupt latency
- Prefetch Cache module to speed execution from Flash

### **Microcontroller Features:**

- Operating voltage range of 2.3V to 3.6V
- 512K Flash memory (plus an additional 12 KB of Boot Flash)
- 128K SRAM memory
- Pin-compatible with most PIC24/dsPIC® DSC devices
- Multiple power management modes
- Multiple interrupt vectors with individually programmable priority
- Fail-Safe Clock Monitor mode
- Configurable Watchdog Timer with on-chip Low-Power RC oscillator for reliable operation

### **Peripheral Features:**

- Atomic SET, CLEAR and INVERT operation on select peripheral registers
- 8-channels of hardware DMA with automatic data size detection
- USB 2.0-compliant full-speed device and On-The-Go (OTG) controller:
  - Dedicated DMA channels
- 10/100 Mbps Ethernet MAC with MII and RMII interface:
  - Dedicated DMA channels
- CAN module:
  - 2.0B Active with DeviceNet™ addressing support
  - Dedicated DMA channels
- 3 MHz to 25 MHz crystal oscillator
- Internal 8 MHz and 32 kHz oscillators
- Six UART modules with:
  - RS-232, RS-485 and LIN 1.2 support
- IrDA® with on-chip hardware encoder and decoder
- Four SPI modules
- Five I<sup>2</sup>C™ modules
- Separate PLLs for CPU and USB clocks
- Parallel Master and Slave Port (PMP/PSP) with 8-bit and 16-bit data, and up to 16 address lines

- Hardware Real-Time Clock and Calendar (RTCC)
- Five 16-bit Timers/Counters (two 16-bit pairs combine to create two 32-bit timers)
- Five Capture inputs
- Five Compare/PWM outputs
- Five external interrupt pins
- High-speed I/O pins capable of toggling at up to 80 MHz
- High-current sink/source (18 mA/18 mA) on all I/O pins
- Configurable open-drain output on digital I/O pins
- Debug Features:
- Two programming and debugging Interfaces:
- 2-wire interface with unintrusive access and real-time data exchange with application
- 4-wire MIPS® standard enhanced Joint Test Action Group (JTAG) interface
- Unintrusive hardware-based instruction trace
- IEEE Standard 1149.2 compatible (JTAG) boundary scan
- Analog Features:**
- 16-channel, 10-bit Analog-to-Digital Converter:
- 1 Msps conversion rate
- Conversion available during Sleep and Idle
- Two Analog Comparators
- 5V tolerant input pins (digital pins only)

# BLOCK DIAGRAM:

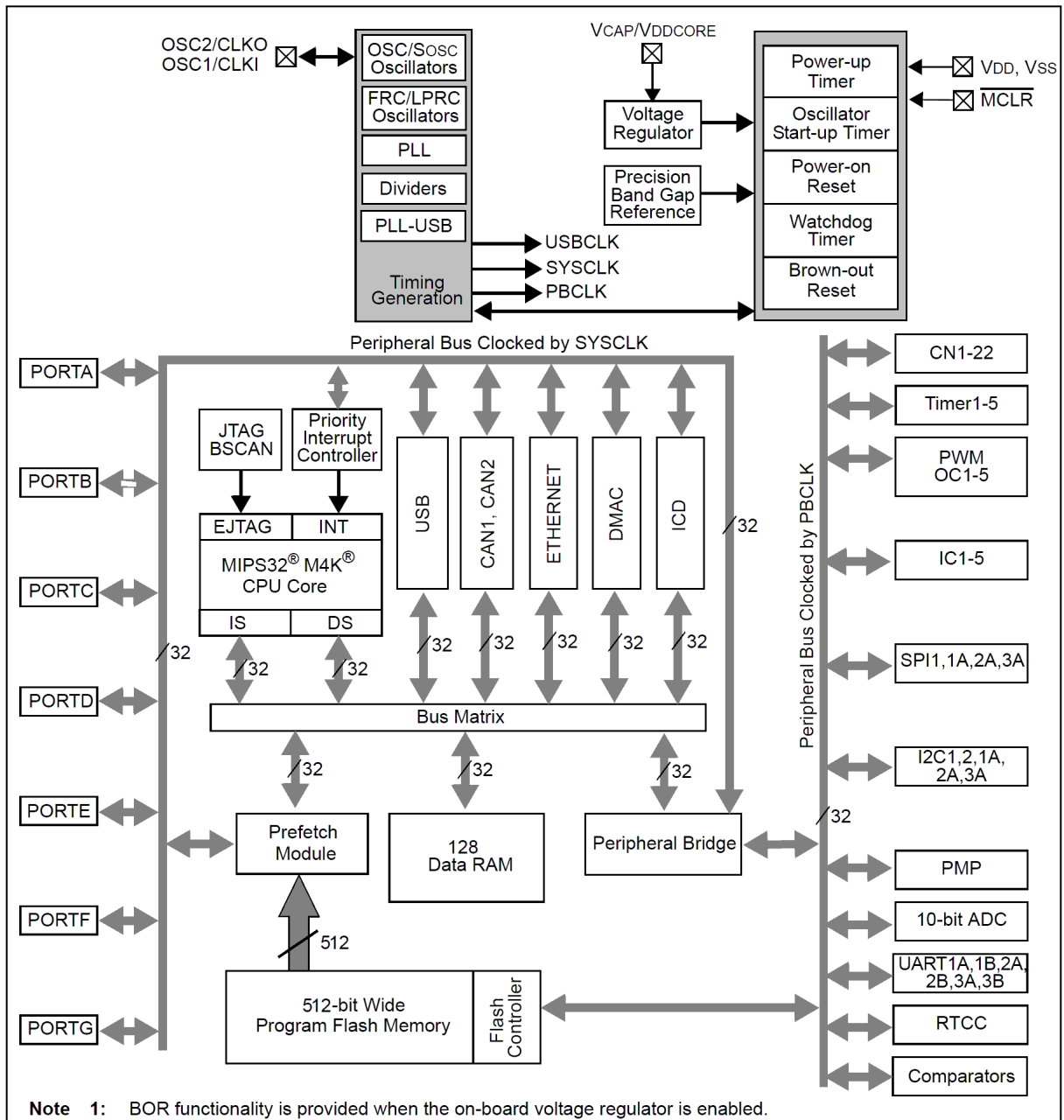

# MEMORY MAP:

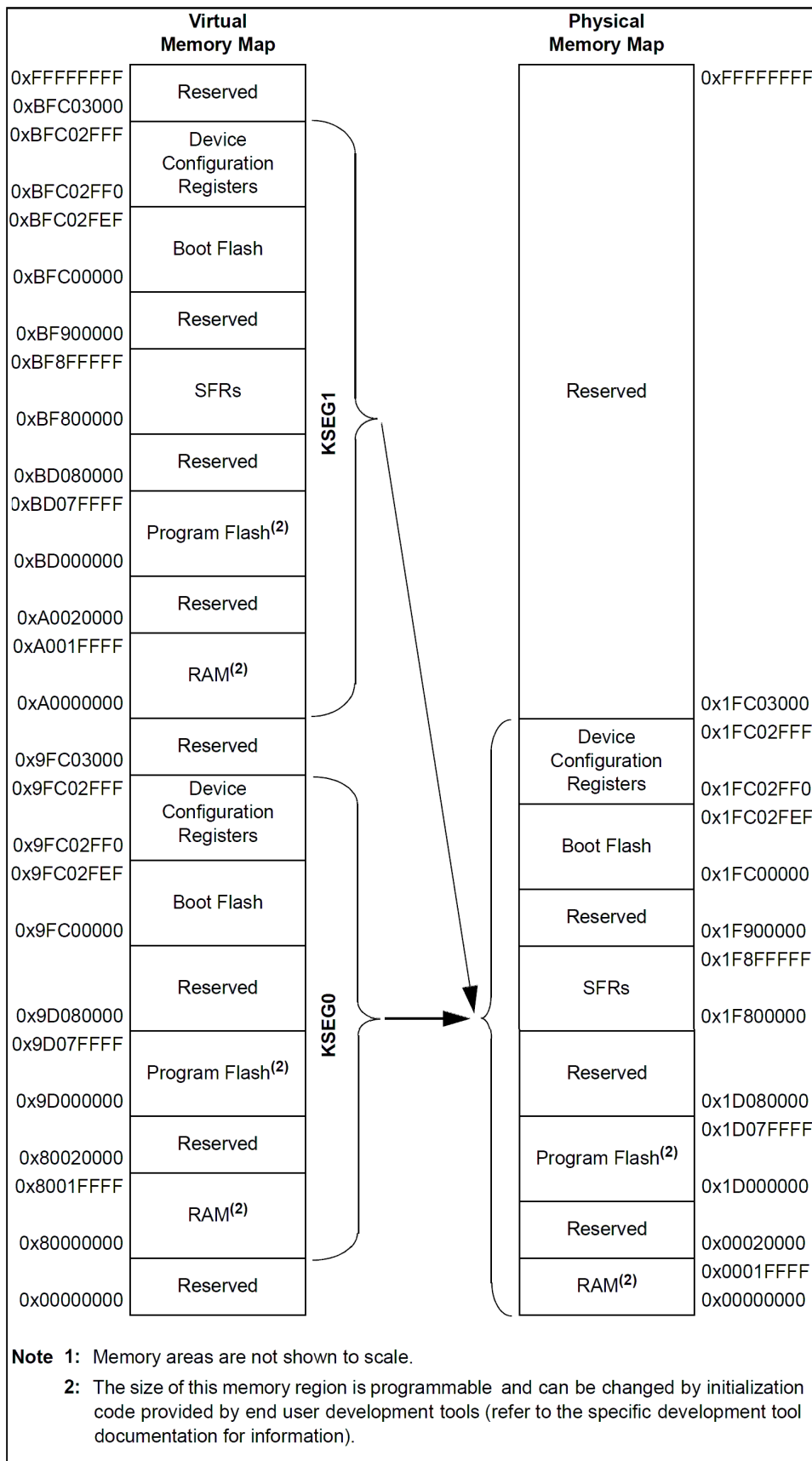

# SCHEMATIC:

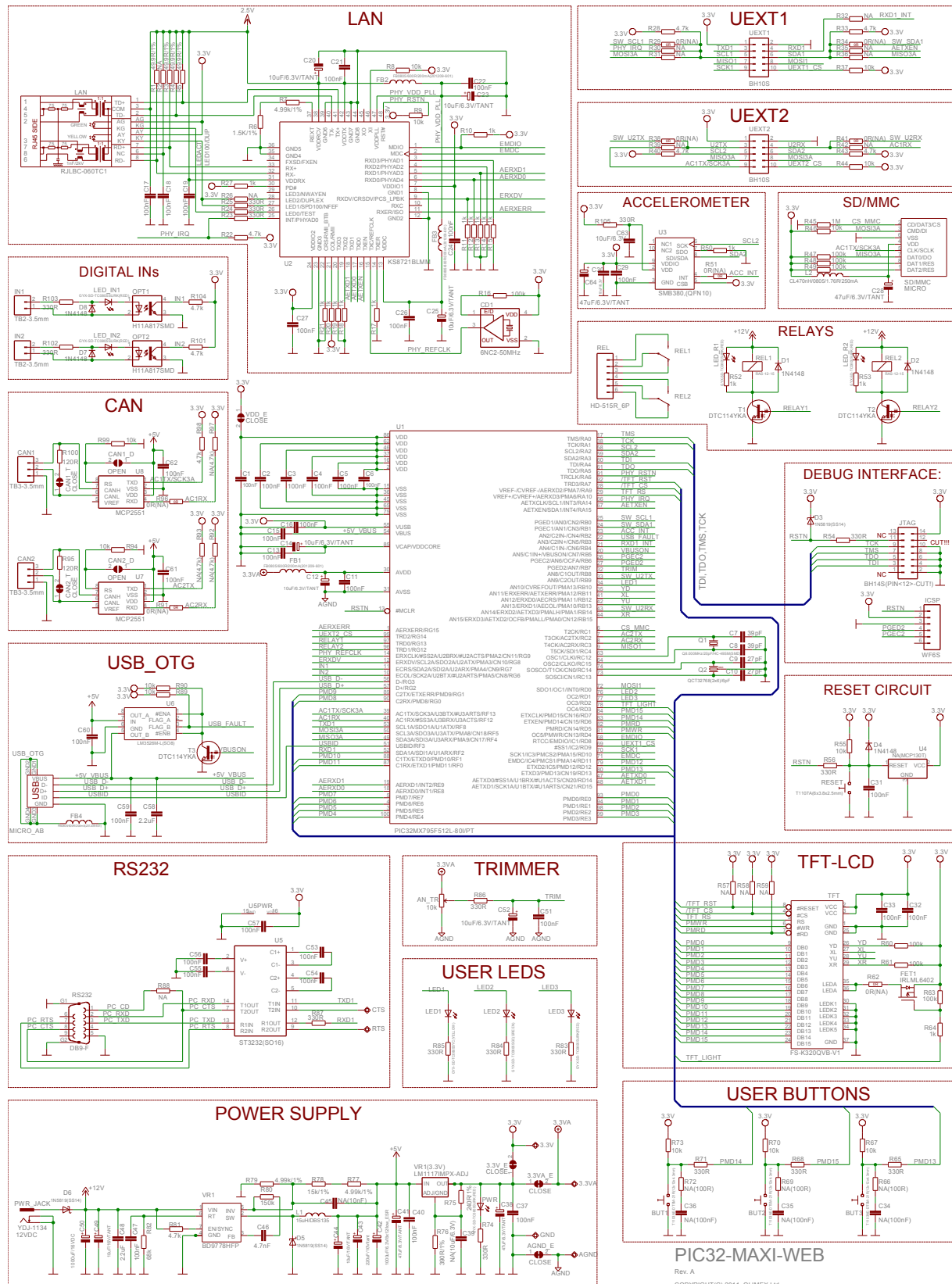

PIC32-MAXI-WEB

Rev. A  
 COPYRIGHT(C) 2011, OLIMEX LTD.  
 http://www.olimex.com/dev



## BOARD LAYOUT:

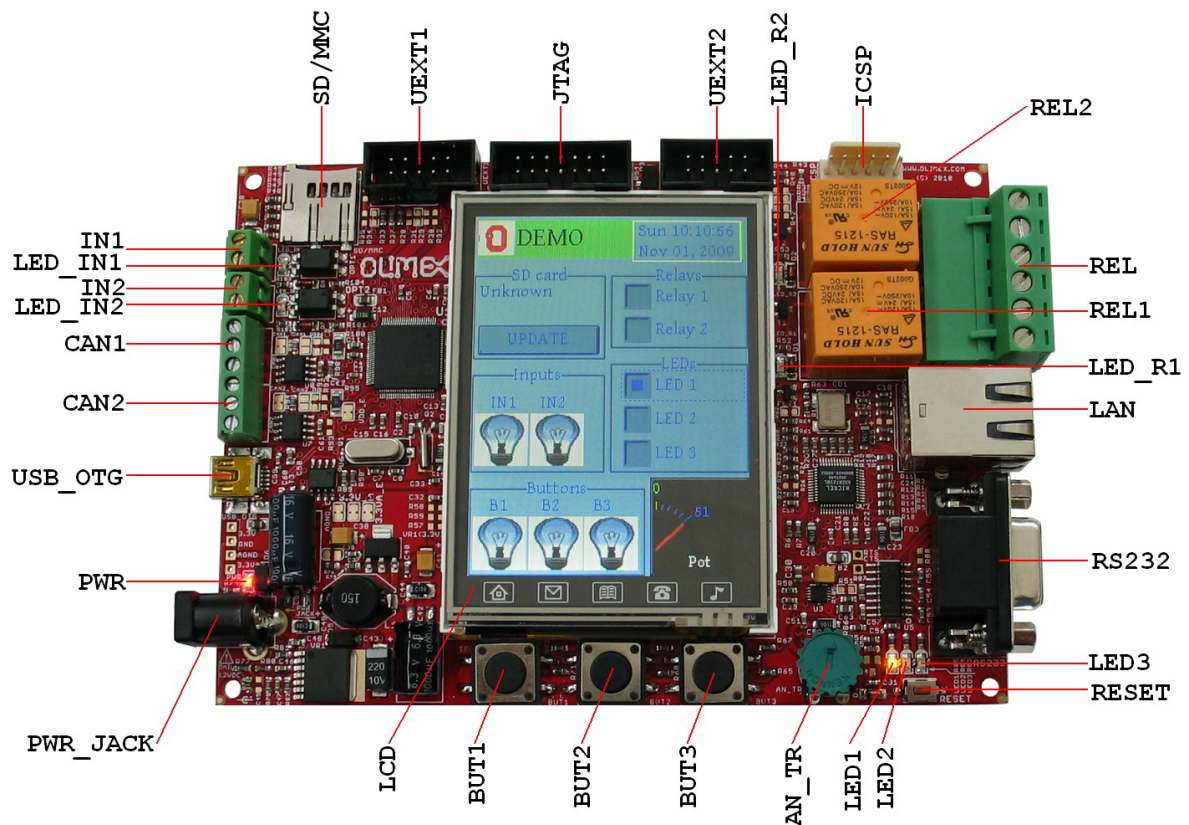

## POWER SUPPLY CIRCUIT:

PIC32-MAXI-WEB can take power only from power connector PWR\_JACK, where only 12 VDC external voltage source has to be applied.

The board power consumption is about 300mA with all peripherals and MCU running at full speed, relays and LEDs on and working Ethernet connection.

## RESET CIRCUIT:

PIC32-MAXI-WEB reset circuit is made of D4 (1N4148), RC group R55 - 10k and C31 - 100nF. Serial resistor R56 - 330Ω is used to prevent fast C31 charge and discharge when PIC32MX795F512L is being programmed. Manual reset is possible by the RESET button.

## CLOCK CIRCUIT:

Quartz crystal Q1 8MHz is connected to PIC32MX795F512L pins 63 (OSC1/CLKI/RC12) and 64 (OSC2/CLKO/RC15).

Quartz crystal Q2 32.768 KHz is connected to PIC32MX795F512L pins 73 (SOSCI/CN1/RC13) and 74 (SOSCO/T1CK/CN0/RC14).

## **JUMPER DESCRIPTION:**

**3.3V\_E**



Enables 3.3V supply for PIC32MX795F512L and all other devices.

Default state closed (shorted).

**3.3VA\_E**



Enables 3.3V positive supply for analog modules.

Default state is closed (shorted).

**VDD\_E**



Enables PIC32MX795F512L's 3.3V power supply.

Default state is closed (shorted).

**AGND\_E**



Enables the analog ground.

Default state is closed (shorted).

**CAN1\_T**



This jumper assures correct work of the CAN1. At each end of the bus it should be closed. This means that if you have only two devices with CAN, the jumpers of both devices should be closed. If you have more than two devices, only the two end devices should be closed.

Default state is closed (shorted).

**CAN1\_D**



CAN Disable. If this jumper is closed, the CAN1 is disabled.

Default state is open (not shorted).

**CAN2\_T**



This jumper assures correct work of the CAN2. At each end of the bus it should be closed. This means that if you have only two devices with CAN, the jumpers of both devices should be closed. If you have more than two devices, only the two end devices should be closed.

Default state is closed (shorted).

**CAN2\_D**



CAN Disable. If this jumper is closed, the CAN2 is disabled.

Default state is open (not shorted).

## INPUT/OUTPUT:

**User button** with name **BUT1** – connected to PIC32MX795F512L pin 83 (ETXEN/PMD14/CN15/RD6).

**User button** with name **BUT2** – connected to PIC32MX795F512L pin 84 (ETXCLK/PMD15/CN16/RD7).

**User button** with name **BUT3** – connected to PIC32MX795F512L pin 80 (ETXD3/PMD13/CN19/RD13).

**Reset button** with name **RESET** – connected to PIC32MX460F512L pin 13 (#MCLR).

One **analog trimmer** with name **AN\_TR** – connected to PIC32MX795F512L pin 32 (AN8/C1OUT/RB8).

**Status Led (yellow)** with name **LED1** – connected to PIC32MX795F512L pin 34 (AN10/CVREFOUT/PMA13/RB10).

**Status Led (green)** with name **LED2** – connected to PIC32MX795F512L pin 76 (OC2/RD1).

**Status Led (red)** with name **LED3** – connected to PIC32MX795F512L pin 77 (OC3/RD2).

Two **optoisolated** digital inputs **IN1** and **IN2**.

Two red **LEDs** – **LED\_IN1** and **LED\_IN2** for every digital input.

Two red **LEDs** – **LED\_R1**, **LED\_R2** – for the relays.

Power supply red **LED** with name **PWR** – indicates that 3.3V power supply is available.

**TFT LCD Display** - FS-K320QVB-V1

## EXTERNAL CONNECTOR DESCRIPTION:

### ICSP:

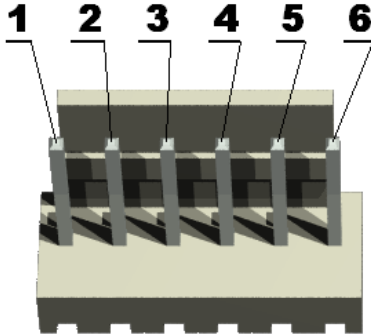

Pin #	Signal Name
1	RSTN
2	3.3V
3	GND
4	PGED2
5	PGEC2
6	NC

**PGED2 I/O** **Program Data.** Serial data for programming.

**PGEC2 Input** **Program Clock.** Clock used for transferring the serial data (output from ICSP, input for the MCU).

### RS232:

Pin #	Signal Name
1	PC_CD
2	PC_RXD
3	PC_TXD
4	NC
5	GND
6	NC
7	PC_RTS
8	PC_CTS
9	NC

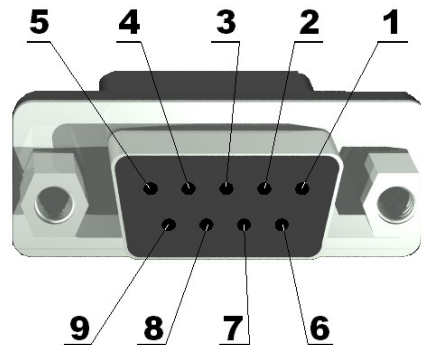

**TXD** Output **Transmit Data.** This is the asynchronous serial data output (RS232) for the shift register on the UART controller.

**RXD** Input **Receive Data.** This is the asynchronous serial data input (RS232) for the shift register on the UART controller.

## LAN:

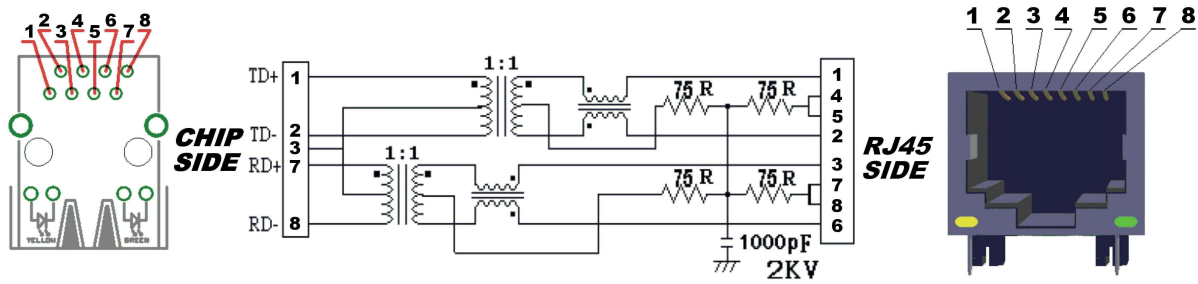

Pin #	Signal Name Chip Side	Pin #	Signal Name Chip Side
1	TX+	5	Not Connected (NC)
2	TX-	6	Not Connected (NC)
3	VCC/2 (2.5V)	7	RX+
4	Not Connected (NC)	8	RX-

LED	Color	Usage
Left	Yellow	100MBits/s (Half/Full duplex)
Right	Green	Activity

## REL:

Pin #	Signal Name	
1	Normal Open	REL1
2	Common	
3	Normal Close	
4	Normal Open	REL2
5	Common	
6	Normal Close	

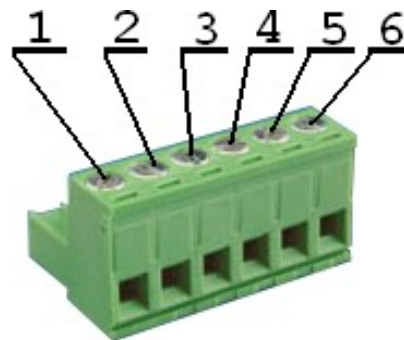

### CAN1:

Pin #	Signal
1	GND
2	CANL
3	CANH

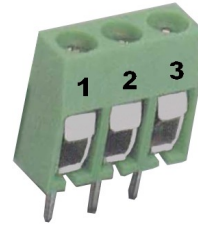

### CAN2:

Pin #	Signal
1	GND
2	CANL
3	CANH

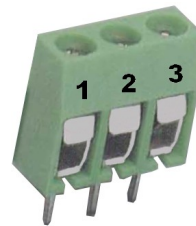

### JTAG:

Pin #	Signal Name
1	NC
2	GND
3	TDI
4	GND
5	TDO
6	GND
7	TMS
8	GND
9	TCK
10	GND
11	RSTN
12	CUT
13	NC
14	3.3 V

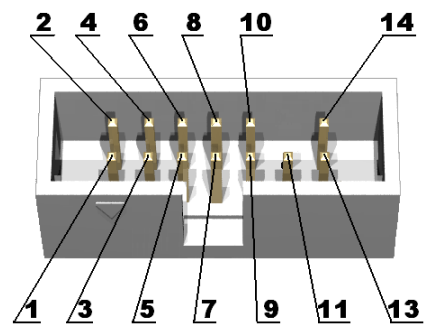

## PWR JACK:

Pin #	Signal Name
1	Power Input
2	GND

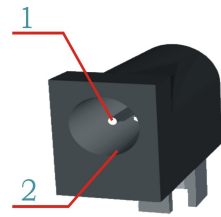

## USB OTG

Pin #	Signal Name
1	+5V_VBUS
2	USB_D-
3	USB_D+
4	USBID
5	GND

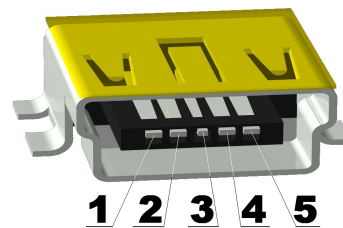

## UEXT1:

Pin #	Signal Name
1	3.3 V
2	GND
3	TXD1
4	RXD1
5	SCL1
6	SDA1
7	MISO1
8	MOSI1
9	SCK1
10	UEXT1_CS

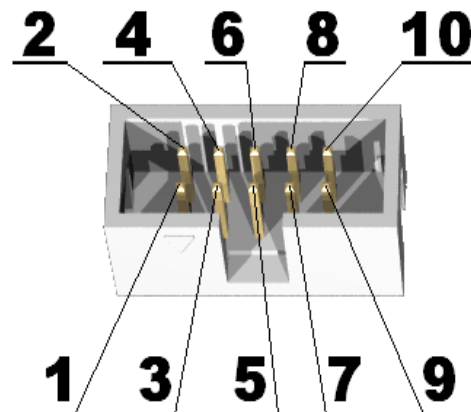

## UEXT2:

Pin #	Signal Name
1	3.3 V
2	GND
3	U2TX
4	U2RX
5	SCL2
6	SDA2
7	MISO3A
8	MOSI3A
9	AC1TX/SCK3A
10	UEXT2_CS

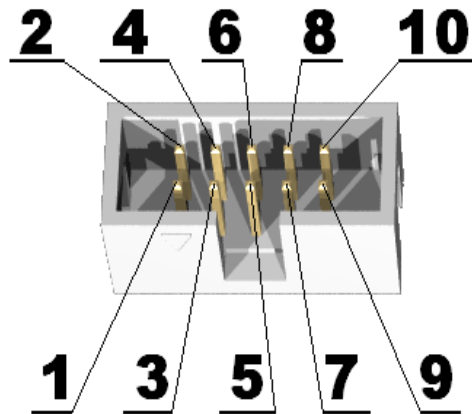

## SD/MMC:

Pin #	Signal Name
1	MCIDAT2
2	CS_MMC
3	MOSI3A
4	VDD (3.3 V)
5	AC1TX/SCK3A
6	GND
7	MISO3A
8	MCIDAT1
9	Not Connected
10	Not Connected
11	Not Connected
12	Not Connected

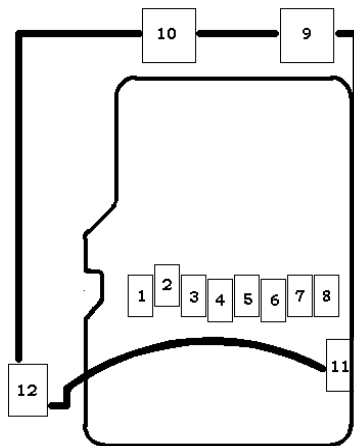



# MECHANICAL DIMENSIONS:

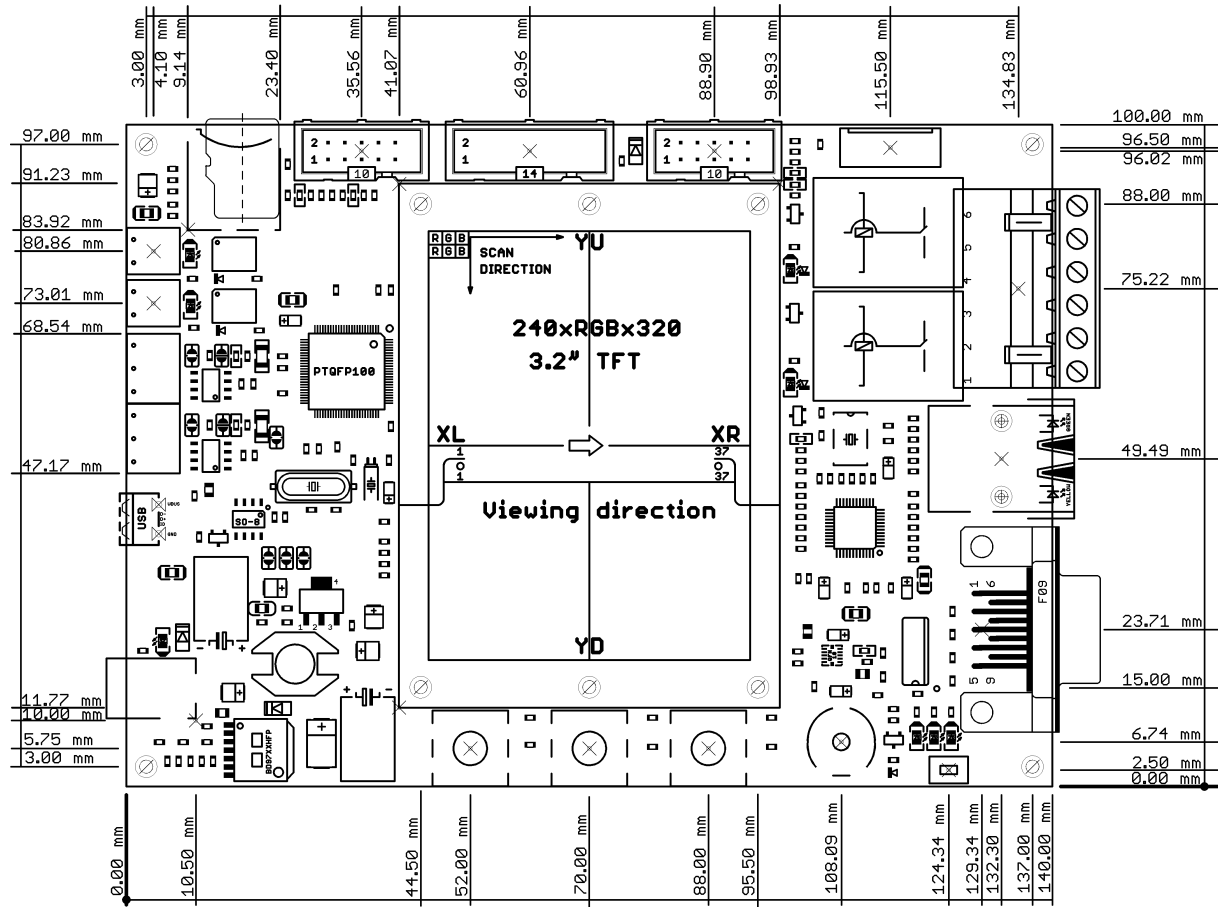

## AVAILABLE DEMO SOFTWARE:

You could find demo software for PIC32-MAXI-WEB board on [www.olimex.com/dev](http://www.olimex.com/dev).

- DemoSoft PIC32-MAXI-WEB v.1.00

### Description:

The demo demonstrates the functionality of the various peripherals of the board including user input, serial communication, Graphical User Interface (GUI) and Network connectivity

The demo is built upon the following Microchip's freely distributed support libraries:

- Microchip Graphics Library v2.00
- Microchip TCP/IP Stack Library v.5.20
- Microchip MDD File System Library
- Microchip USB support source files

FreeRTOS was used to make all tasks run virtually simultaneously. FreeRTOS is a freely distributed RTOS with excellent support and online documentation. Version used is v6.0.2. MPLAB has support for FreeRTOS (Tools/RTOS viewer).

Upon power up the user is presented with a welcome screen. Pressing the screen leads you to the demo screen which contains controls for nearly all the peripheral features of the board. To test the functionality of the buttons press button and its corresponding virtual light bulb will be lit. Digital optoinsulated inputs act the same way, but at least 3V must be applied to the terminal block of the input. LEDs and Relays can be toggled by clicking inside their respective checkboxes. Potentiometer controls the meter widget at the lower right corner of the screen. To test the SD card slot just insert a FAT formatted SD card in the slot and press the UPDATE button at the upper left corner of the screen - you'll see information about the size of the card as well as sector size. This demo also implements a USB device function - just connect a miniUSB cable to the board and a HID mouse device should be installed and started (the cursor should draw octagons onscreen), no drivers necessary.

This demo program implements a WEB server (and a ICMP server for test purposes). After connecting the LAN cable to the board the TCP/IP stack is initialized and an attempt is made to get a valid IP address. In the presence of a DHCP server the IP is received automatically (as well as subnet mask, gateway etc.). Otherwise defaults defined in 'TCPIPConfig.h' are used:

IP:	192.168.0.113
Subnet mask:	255.255.255.0
Gateway:	192.168.0.1
DNS1:	192.168.0.1

To access the WEB server you need a way to determine the current IP address of the board. If you connect a RS232 straight cable to a PC and start any terminal program with the following settings: 9600-8-N-1, IP address info will be displayed in the terminal window. The last entry defines the currently assigned IP address. Enter this IP in the address bar of your favourite browser (for ex. <http://192.168.0.113>) and you'll access a demo page which dynamically updates status of many of the peripherals present on the board. Try it :). You'll see values of the embedded accelerometer, potentiometer, buttons, digital inputs, LEDs and relays.

\*NOTE: CAN modules demo can be found inside the file 'Additional Projects.zip' as this feature is not part of the main demo.

Build info:

MPLAB IDE v8.50

MPLAB C32 v1.10B

Microchip Graphics Library v2.00

FreeRTOS v6.0.2

Debugger used:

PICKit3 by Microchip

## **ORDER CODE:**

**PIC32-MAXI-WEB** – assembled and tested (no kit, no soldering required)

How to order?

You can order to us directly or by any of our distributors.

Check our web [www.olimex.com/dev](http://www.olimex.com/dev) for more info.

## **Revision history:**

Rev. A            - created February 2011

**Disclaimer:**

© 2011 Olimex Ltd. All rights reserved. Olimex®, logo and combinations thereof, are registered trademarks of Olimex Ltd. Other terms and product names may be trademarks of others.

The information in this document is provided in connection with Olimex products. No license, express or implied or otherwise, to any intellectual property right is granted by this document or in connection with the sale of Olimex products.

Neither the whole nor any part of the information contained in or the product described in this document may be adapted or reproduced in any material from except with the prior written permission of the copyright holder.

The product described in this document is subject to continuous development and improvements. All particulars of the product and its use contained in this document are given by OLIMEX in good faith. However all warranties implied or expressed including but not limited to implied warranties of merchantability or fitness for purpose are excluded.

This document is intended only to assist the reader in the use of the product. OLIMEX Ltd. shall not be liable for any loss or damage arising from the use of any information in this document or any error or omission in such information or any incorrect use of the product.



## Стандарт Электрон Связь

Мы молодая и активно развивающаяся компания в области поставок электронных компонентов. Мы поставляем электронные компоненты отечественного и импортного производства напрямую от производителей и с крупнейших складов мира.

Благодаря сотрудничеству с мировыми поставщиками мы осуществляем комплексные и плановые поставки широчайшего спектра электронных компонентов.

Собственная эффективная логистика и склад в обеспечивает надежную поставку продукции в точно указанные сроки по всей России.

Мы осуществляем техническую поддержку нашим клиентам и предпродажную проверку качества продукции. На все поставляемые продукты мы предоставляем гарантию .

Осуществляем поставки продукции под контролем ВП МО РФ на предприятия военно-промышленного комплекса России , а также работаем в рамках 275 ФЗ с открытием отдельных счетов в уполномоченном банке. Система менеджмента качества компании соответствует требованиям ГОСТ ISO 9001.

Минимальные сроки поставки, гибкие цены, неограниченный ассортимент и индивидуальный подход к клиентам являются основой для выстраивания долгосрочного и эффективного сотрудничества с предприятиями радиоэлектронной промышленности, предприятиями ВПК и научно-исследовательскими институтами России.

С нами вы становитесь еще успешнее!

### Наши контакты:

**Телефон:** +7 812 627 14 35

**Электронная почта:** [sales@st-electron.ru](mailto:sales@st-electron.ru)

**Адрес:** 198099, Санкт-Петербург,  
Промышленная ул, дом № 19, литера Н,  
помещение 100-Н Офис 331