

# ABC600 Series AC-DC/DC-DC Open-Frame Power Supplies



## Applications

- Instrumentation
- Lighting
- Industrial Applications
- Test and Measurement
- Robotics
- Renewable Energy
- Data Comm.
- Applied Computing
- Process Control
- Wireless

## Features

- 600W standard, 420W convection cooled
- Size: 5.0" x 8.0" x 1.6" (127.0 x 203.2 x 40.6 mm)
- High efficiency up to 94.0%
- Universal input voltage range: 90-277 VAC
- Active power factor correction
- Less than 5 W dissipation at standby mode
- Parallel operation with active current sharing
- Digital control for circuit loop and power management
- Fully protected ( OTP, OCP, OVP, SCP )
- PMBus™ for control, programming and monitoring
- Both AC input and DC input are available
- Designed to meet Class B per CISPR 22 and EN 55022
- Approved to the latest edition of the following standards: UL/GSA60950-1 2nd Ed., EN60950-1 2nd Ed., and IEC60950-1 2nd Ed.
- CE marked LVD

**North America**  
+1-866.513.2839

**Asia-Pacific**  
+86.755.29885888

**Europe, Middle East**  
+353 61 225 977

Bel Power Solutions  
152 North 3rd Street, Suite 805  
San Jose, CA 95112 USA

tech.support@psbel.com  
[belpowersolutions.com](http://belpowersolutions.com)

© 2014 Bel Power Solutions, inc.

BCD.00336\_AC

# ABC600 Series

## 1. Ordering Information

MODELS	OUTPUT VOLTAGE (VDC)	MAX LOAD CONVECTION	MAX LOAD 300 LFM	MINIMUM LOAD	RIPPLE & NOISE	TOTAL REGULATION
ABC600-1012G	12 V	35.0 A	50.0 A	0A	1%	± 2%
ABC600-1015G	15 V	28.0 A	40.0 A	0A	1%	± 2%
ABC600-1024G	24 V	17.5 A	25.0 A	0A	1%	± 2%
ABC600-1028G	28 V	15.0 A	21.4 A	0A	1%	± 2%
ABC600-1048G	48 V	8.8 A	12.5 A	0A	1%	± 2%
ABC600-1052G	52 V	8.1 A	11.5 A	0A	1%	± 2%
V <sub>fan</sub> (all models)	12 V	1.0 A	1.0 A	0A	1%	± 20%
V <sub>sb</sub> (all models)	5 V	1.0 A	1.0 A	0A	2%	± 2%

### NOTES:

1. Peak current rating on V1 (main output) is 120% of max, lasting 3 second with max of 10% duty cycle.
2. Combined output power of V1 plus fan supply and standby supply should not exceed max power rating.
3. +/-20% tolerance of V<sub>fan</sub> includes the factors of set point accuracy, line and load regulation.
4. Air flow over long edge (either direction) required for air flow rating. See mechanical drawing, Figure 7 on page 11.
5. More than 800K hours MTBF is to be calculated according to Bellcore TR-332 standard current edition at 25 °C

## 2. Overview

The ABC600 SERIES AC-DC/DC-DC power supply can operate using AC or DC input. It is a highly efficient front-end power supply. The PFC stage adopts an analog controller in continuous conduction mode to achieve high power factor and high efficiency. The DC/DC stage is fully DSP controlled and employs soft switching resonant techniques in conjunction with synchronous rectification for high efficiency and better thermal control. With a wide input operational voltage range and minimal linear derating of output power with temperature, the ABC600 SERIES maximizes power availability in demanding server, network, and other high availability applications. The supply is convection cooled or fan cooled and ideally suited for integration with a matching airflow path. An active OR-ing MOSFET on the output ensures no reverse current and renders the supply ideally suited for operation in redundant power systems. The always-on standby output V<sub>sb</sub> (5Volts) provides power to external power distribution and management controllers. It is protected with an active OR-ing diode for maximum reliability. In addition, the PMBus allows full monitoring of the supply, including input and output voltage, current, power, and internal temperatures. Current share signal (V1\_I<sub>share</sub>) is used for current sharing, and the difference between two units is within 2.5A if system load is more than 25% of full load. The current share signal (V1\_I<sub>share</sub>) voltage shall be a linear function  $V_{cs} = 8 \times I_{out}/I_{max}$  for a single power supply. Example: for ABC600-1012G, VCS is 8 V at 50A loading; I<sub>max</sub> is 50A of ABC600-1012G.

# ABC600 Series

Figure 1: ABC600 SERIES Block Diagram

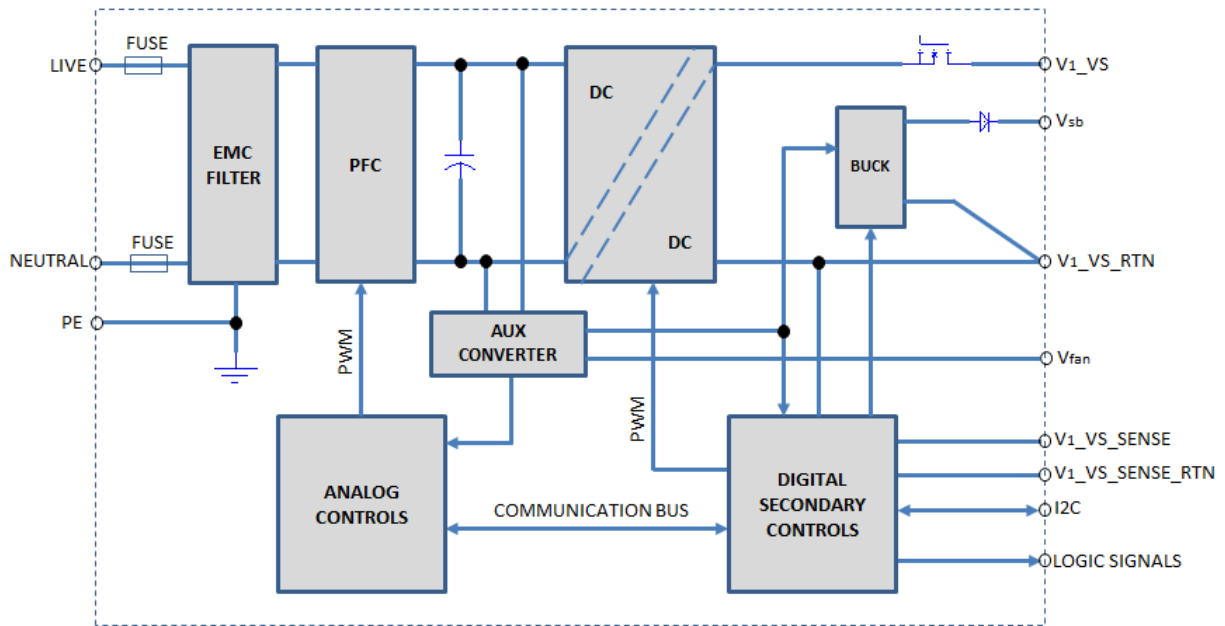

## 3. Input

General Condition:  $T_{amb} = -25$  to  $70^{\circ}\text{C}$  unless otherwise noted.

PARAMETER	DESCRIPTION / CONDITION	MIN	NOM	MAX	UNIT		
$V_{in}$	Input Voltage Ranges	90 120	100-250	277 390	VAC VDC		
$I_{in\ max}$	Max Input Current	$V_{in}=90\text{VAC}/60\text{Hz}$ , Full load			9	Arms	
$I_{inrush}$	Inrush Current Limitation	$V_{i\ min}$ to $V_{i\ max}$ ,			20	Apk	
$F_i$	Input Frequency	47	50/60	63	Hz		
PF	Power Factor	$V_{in\ nom}$ , 50Hz, >50% full load.			0.95	0.99	1
$\eta$	Efficiency without Fan	$V_{in}=230\text{VAC}$ , 20% of Full load, $T_{amb} = 25^{\circ}\text{C}$			91.0	%	
		$V_{in}=230\text{VAC}$ , 50% of Full load,, $T_{amb} = 25^{\circ}\text{C}$			94.0		
		$V_{in}=230\text{VAC}$ , 100% of Full load,, $T_{amb} = 25^{\circ}\text{C}$			93.0		
$P_{min}$	Min Power at no Load	$V_{in}=120\text{VAC}$ , $T_{amb} = 25^{\circ}\text{C}$ , if diable V1			5	W	
$I_{Leakage}$	Leakage Current	$V_{in}=120\text{VAC}$ , $T_{amb} = 25^{\circ}\text{C}$ , Input to Earth			3	mA	
		$V_{in}=277\text{VAC}$ , $T_{amb} = 25^{\circ}\text{C}$ , Input to Earth			3	mA	
$T_{hold}$	Hold-up Time	16	$V_{in} = 230\text{VAC}$ , Full load, $V_{sb}$ within regulation, stay within $90\% \cdot V_{1nom}$ from AC zero point			mS	

# ABC600 Series

## 4. Output

General Condition:  $T_{amb} = -25$  to  $70^{\circ}\text{C}$  unless otherwise noted.

PARAMETER	DESCRIPTION / CONDITION	MIN	NOM	MAX	UNIT		
<b>Main Output V1</b>							
$V_{1\ set}$	Output Set point Accuracy	$0.5 \cdot I_{1\ nom}$ , $T_{amb} = 25^{\circ}\text{C}$		-0.5	+0.5	% $V_{1\ nom}$	
$V_{1\ nom}$	Nominal Output Voltage	Refer to ordering information table as above				VDC	
$V_{1\ total\ reg}$	Total Regulation	$V_{in\ min}$ to $V_{in\ max}$ , 0 to 100% $I_{1\ nom}$ , $T_{amb\ min}$ to $T_{amb\ max}$		-2	+2	% $V_{1\ nom}$	
$V_{adj}$	Voltage Adjustment	V1 output voltage could be adjusted with the potentiometer or I2C protocol		+/-10		% $V_{1\ nom}$	
$V_{1\ pp}$	Output Ripple Voltage	$V_{1\ nom}$ , $I_{1\ nom}$ , 20MHz BW #1				1	% $V_{1\ nom}$
$V_{1\ Load\ reg}$	Load Regulation	$V_i = V_{i\ nom}$ , 0...100 % $I_{1\ nom}$				2	% $V_{1\ nom}$
$V_{1\ Line\ reg}$	Line Regulation	$V_i = V_{i\ min} \dots V_{i\ max}$				1	% $V_{1\ nom}$
$I_{share}$	Current Sharing abs (I1-I2), between any two units in parallel)	when Bus load $\geq$ 25% of full load				2.5	A
		when Bus load $<$ 25% of full load #2				3.5	A
$V_{1\ dyn}$	Dynamic Load Regulation	50 to 100% of load change, 50 Hz, 50% duty cycle, 1A/us		-5	+5	% $V_{1\ nom}$	
$T_{v1\ rec}$	Recovery Time			0.5		5	mS
$V_{1\ Overshoot}$	V1 overshoot at turn-on					1	%
$C_{v1\ Load}$	Capacitive Loading	$T_{amb} = 25^{\circ}\text{C}$ , $C_{Load} = 220\mu\text{F}/\text{A} \cdot I_{1\ nom}$					$\mu\text{F}$
<b>Standby output Vsb</b>							
$V_{sb\ nom}$	Nominal Output Voltage			5			VDC
$V_{sb\ total\ reg}$	Total Regulation	$V_{sb\ min}$ to $V_{sb\ max}$ , 0 to 100% $I_{sb\ nom}$ , $T_{amb\ min}$ to $T_{amb\ max}$		-2	+2	% $V_{sb}$	
$P_{sb\ nom}$	Nominal Output Power	$V_{sb} = 5\ \text{VDC}$		5			W
$V_{sb\ pp}$	Output Ripple Voltage	$V_{sb\ nom}$ , $I_{sb\ nom}$ , 20MHz BW				100	mV
$V_{sb\ Load\ reg}$	Load Regulation	$V_{sb} = V_{sb\ nom}$ , 0...100 % $I_{sb\ nom}$				2	% $V_{sb}$
$V_{sb\ Line\ reg}$	Line Regulation	$V_{sb} = V_{sb\ min} \dots V_{sb\ max}$				2	% $V_{sb}$
$I_{sb\ max}$	Current Limitation	Constant current limit then hiccup		120	150	% $I_{sb}$	
$V_{sb\ dyn}$	Dynamic Load Regulation	50 to 100% of load change, 50 Hz, 50% duty cycle, 1A/us		-5	+5	% $V_{sb}$	
$T_{sb\ rec}$	Recovery Time			0.5		5	mS
$C_{sb\ Load}$	Capacitive Loading	$T_{amb} = 25^{\circ}\text{C}$				220	$\mu\text{F}$
<b>Fan output Vfan</b>							
$V_{fan\ nom}$	Nominal Output Voltage			12			VDC
$V_{fan\ total\ reg}$	Total Regulation	$V_{fan\ min}$ to $V_{fan\ max}$ , 0 to 100% $I_{1\ nom}$ , $T_{amb\ min}$ to $T_{amb\ max}$		-20	+20	% $V_{fan\ nom}$	
$P_{fan\ nom}$	Nominal Output Power	$V_{fan} = 12\ \text{VDC}$ , Power derating linearly to 50% at $70^{\circ}\text{C}$ , refer to figure 2		12			W
$V_{fan\ pp}$	Output Ripple Voltage	$V_{fan\ nom}$ , $I_{fan\ nom}$ , 20MHz BW				2	% $V_{fan\ nom}$
$I_{fan\ max}$	Current Limitation	$T_{amb} = 25^{\circ}\text{C}$		270		% $I_{fan\ nom}$	
$V_{fan\ dyn}$	Dynamic Load Regulation	50 to 100% of load change, 50 Hz, 50% duty cycle, 1A/us		-5	+5	% $V_{fan\ nom}$	
$T_{fan\ rec}$	Recovery Time			0.5		5	mS
$C_{fan\ Load}$	Capacitive Loading	$T_{amb} = 25^{\circ}\text{C}$				220	$\mu\text{F}$

### NOTES:

- The output noise and ripple measurement was made with 20MHz bandwidth using a 6 inch twisted pair, terminated with a 10 uF tantalum capacitor in parallel with a 0.1uF ceramic capacitor.
- For ABC600-1048G/52G, the current share abs (I1-I2) should be less than 3A at light load (<25% of full load).

# ABC600 Series

Figure 2: Output Power vs. Temperature

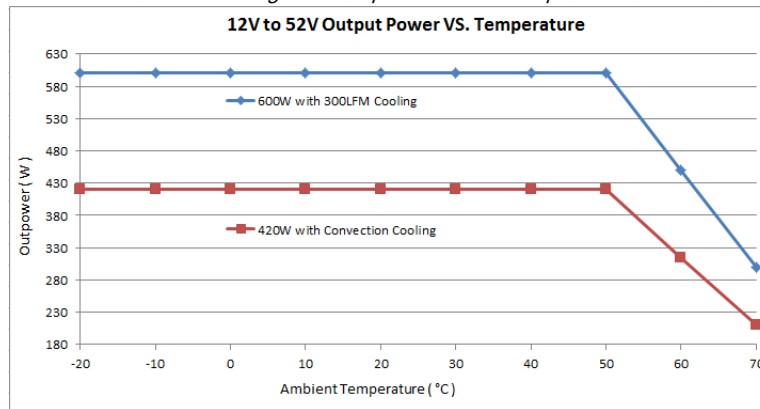

NOTE: Power derating linearly to 50% at 70°C for the output including main output V1, Vfan.

## 5. Protection

PARAMETER	DESCRIPTION / CONDITION	MIN	NOM	MAX	UNIT	
F	Input Fuses (L+N)	Not user accessible, slow-acting (F)			A	
V <sub>in ov</sub>	Input Over Voltage Limit	285VAC/395VDC	/	295VAC/405VDC	V	
	Recovery	280VAC/390VDC	/	290VAC/400VDC	V	
V <sub>in uv</sub>	Input Under Voltage Limit	75VAC/105VDC	/	85VAC/115VDC	V	
	Recovery	80VAC/110VDC	/	90VAC/120VDC	V	
V <sub>1 ov</sub>	OV Threshold V <sub>1</sub>	110		132	%V <sub>1 nom</sub>	
V <sub>sb ov</sub>	OV Threshold V <sub>sb</sub>	110		120	%V <sub>sb nom</sub>	
I <sub>1 lim</sub>	Current Limit V <sub>1</sub>	Over current limit meet below curve, Figure 3				
I <sub>sb lim</sub>	Current Limit V <sub>sb</sub>	1.2		2	A	
I <sub>fan lim</sub>	Current Limit V <sub>fan</sub>	T <sub>amb</sub> = 25°C			2.7	A
T <sub>SD</sub>	Over Temperature On Heat Sinks	No damage, Automatic shut-down and recovers.				

The Output is protected against an overload or a Short Circuit for indefinite duration. The unit shall meet this requirement when in general operating conditions. Over current limit should meet below curve within +/-1.5A tolerance, and the unit is allowed to hiccup under over current conditions

Figure 3: Over Current Mode

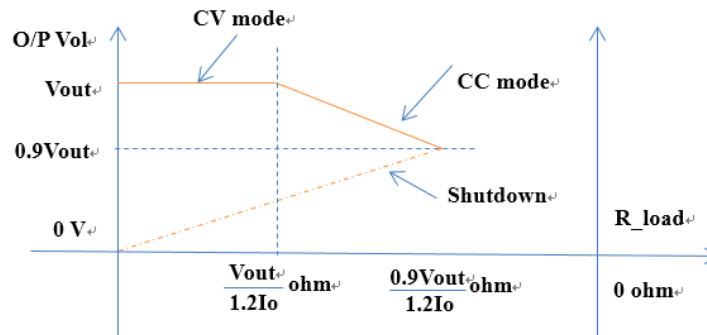

# ABC600 Series

## 6. Graphical User Interface

Bel Power Solution provides with its “Bel Power Solution I2C Utility” a Windows® XP/Vista/Win7 compatible graphical user interface allowing the programming and monitoring of the ABC600 Series Front-End. The utility can be downloaded on [www.belpowersolutions.com](http://www.belpowersolutions.com) and supports both the PSMI and PMBus™ protocols.

The GUI allows automatic discovery of the units connected to the communication bus and will show them in the navigation tree. In the monitoring view the power supply can be controlled and monitored.

Reference Documents:

- BCA.00029\_AA\_ABC600 Series PMBus Communication Manual.pdf
- PMBus Specification Part I Revision 1.1
- PMBus Specification Part II Revision 1.1
- System Management Bus (SMBus) Specification Revision 2.0

Figure 4: I2C Bus to DSP

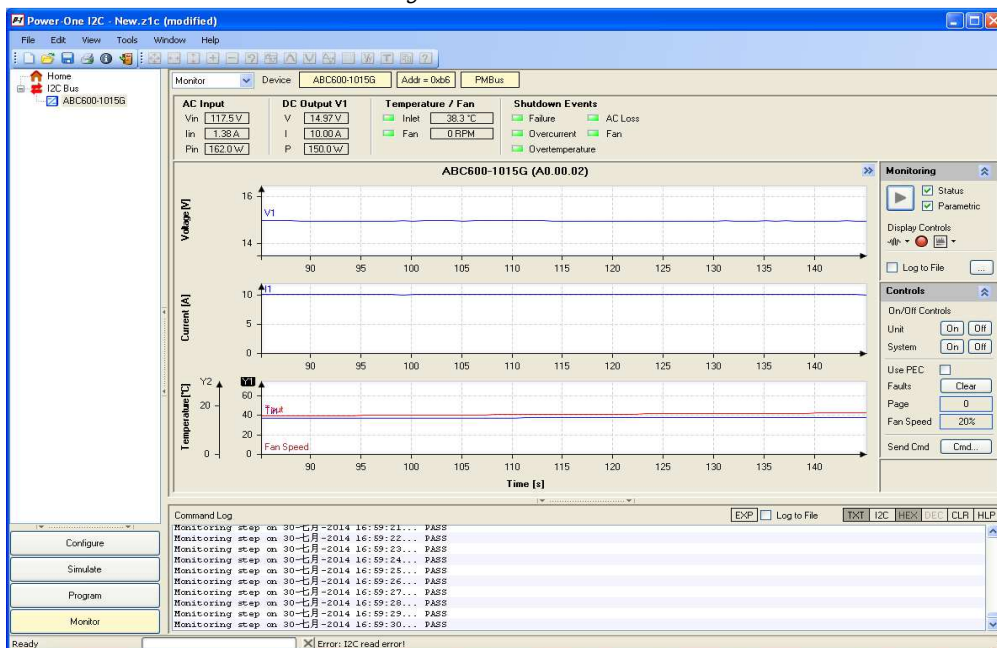

The sensor commands shall meet the following accuracy requirements.

COMMAND	10%-20% OF MAX LOAD	20%-100% OF MAX LOAD	Remark
READ_IIN	< 0.5A	+/-20 %	It is for corresponding to max input current
READ_IOUT	+/-5 %	+/-2.5A	It is for corresponding to max output current
READ_VIN	+/-3 %	+/-2.5V	It is for corresponding to max input voltage
READ_VOUT	+/-2 %	+/-2 %	
READ_PIN	- - -	+/-20 %	It is for corresponding to max input power
READ_POUT	+/-5 %	+/-5 %	It is for corresponding to max output power

# ABC600 Series

## 7. Timing Diagram and Signals

Unless defined otherwise, all control signals shall be TTL compatible with respect to the output return and shall be isolated from the primary circuit and be SELV rated. All input signals shall be driven from an open collector with the pull-up resistor located in the power supply and shall be capable of sourcing up to 4 mA. Unless otherwise specified, signal levels for parameters listed in the table below are general LVTTTL signals.

PARAMETER	DESCRIPTION/CONDITION
A0, A1	PMBus selected address Pin.
SDA, SCL	SDA is serial data signal and SCL is serial clock signal (I2C).
SMB_ALERT_L	Output alert signal. It shall be an open collector with the pull-up resistor located at the receiving end. This signal will be asserted due to fault or warning events. High = Normal, Low = Alert, Refer to Figure 5.
V <sub>1_</sub> Ishare	Current share signal. The PSU can operate at redundant mode by connecting V <sub>1_</sub> Ishare signal of each power supply together.
V <sub>1_</sub> VS_SENSE, V <sub>1_</sub> VS_SENSE_RTN	Remote Sense signal for V1, V <sub>1_</sub> VS_SENSE is positive sense, V <sub>1_</sub> VS_SENSE_RTN is negative sense.
V <sub>sb</sub> , SGND	V <sub>sb</sub> is standby output, and SGND is secondary ground.
+VP	Source voltage located at receiving end. Provide a voltage for power good signal. Refer to Figure 6.
PW_OK_H	Output power good signal. It is isolated from the output. Goes high/low when output is within regulation. Refer to Figure 6 (two methods for Power Good connection).
INHIBIT_L, INHIBIT_L_RTN	Power up signal. It is isolated from the output. Apply a DC voltage between INHIBIT_L and INHIBIT_L_RTN can power up the unit. Refer to Figure 6.
V <sub>fan</sub> , SGND	V <sub>fan</sub> is fan output to provide energy for user, and SGND is secondary ground.

Figure 5: SMB\_ALERT\_L connections

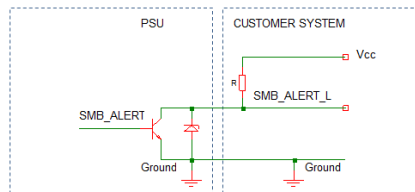
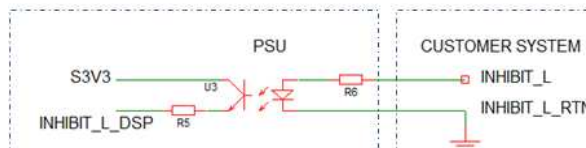
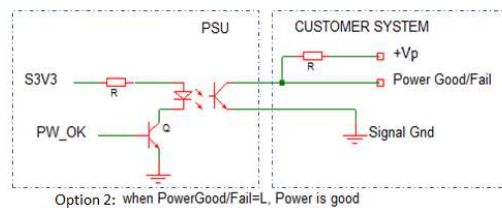
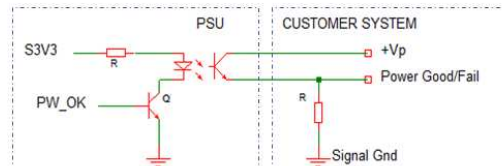

Figure 6: Isolated Signal Output connections



# ABC600 Series

## Low-Voltage TTL (LVTTTL) voltage levels

PARAMETER	SYMBOL	MIN	MAX	UNITS
Output High Voltage	$V_{oh}$	2.4	3.6	V
Output Low Voltage	$V_{ol}$	0	0.4	V
Input High Voltage	$V_{ih}$	2.0	3.6	V
Input Low Voltage	$V_{il}$	0	0.8	V
Sink current(PW_OK_H)	$I_{sink}$		4	mA
Operate voltage (between INHIBIT_L and INHIBIT_L_RTN)	$V_{ope}$	2.0	10	V
Max operate current (SMB_ALERT_L)	$I_{ope}$		30	mA

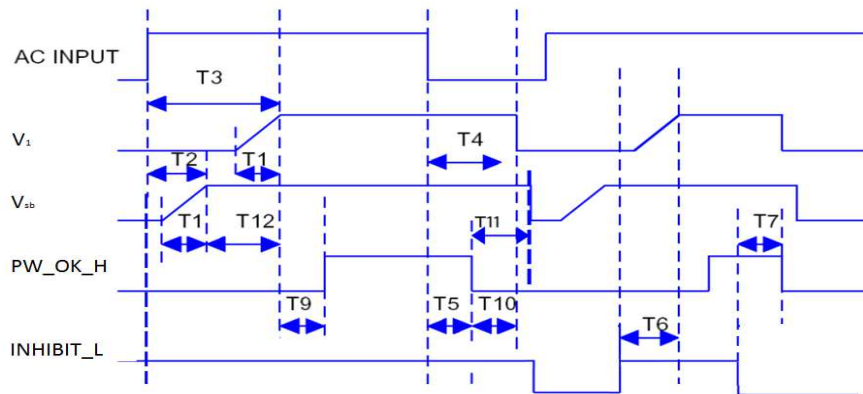

PARAMETER	CONDITION/COMMENTS	MIN	NOM	MAX	UNITS
T1 ( $T_{V_{out\_rise}}$ )	Output voltage rise time from each output	0.5		100	mS
T2 ( $T_{VAC_{on\_Vsb_{on}}}$ )	Delay from AC being applied to $V_{sb}$ being within regulation			2500	mS
T3 ( $T_{VAC_{on\_V1_{on}}}$ )	Delay from AC being applied to $V_1$ being within regulation			3000	mS
T4 ( $T_{V1\_holdup}$ )	Time $V_1$ stay within 90% normal output after loss of AC	16			mS
T5 ( $T_{pwok\_holdup}$ )	Delay from loss of AC to de-assertion of PW_OK_H	10			mS
T6 ( $T_{inhibitL\_V1_{on}}$ )	Delay INHIBIT_L active to $V_1$ output voltages within regulation			1000	mS
T7 ( $T_{inhibitL\_pwok}$ )	Delay from INHIBIT_L de-active to PW_OK_H being de-asserted			50	mS
T9 ( $T_{V1_{on\_pwok}}$ )	Delay from $V_1$ within regulation to PW_OK_H asserted at turn on	100		1000	mS
T10 ( $T_{pwok_{off\_V1}}$ )	Delay from PW_OK_H de-asserted to $V_1$ dropping out of regulation			10	mS
T11 ( $T_{pwok_{off\_Vsb}}$ )	Delay from PW_OK_H de-asserted to $V_{sb}$ dropping out of regulation	20			mS
T12 ( $T_{Vsb\_V1}$ )	Delay from $V_{sb}$ being in regulation to $V_1$ being in regulation at AC turn on	50		1000	mS



# ABC600 Series

## 8. Environmental

PARAMETER	DESCRIPTION/CONDITION	CRITERION
Operating Temperature	See derating charts above Figure 2, $T_{amb\ min} = -25^{\circ}C$ , $T_{amb\ max} = 70^{\circ}C$	-25 to 70°C
Storage Temperature		-40 to 85°C
Relative Humidity	Operating humidity: Non-operating humidity, non-condensing	5%-90% 5%-95%
Altitude	Operating: Non-operating:	10,000 ft. 40,000 ft.
CE Mark	Complies with LVD Directive	
Conducted Emissions:	EN55022-B, CISPR22-B, FCC PART15-B	Criterion B
Static Discharge	EN61000-4-2, Level-3	Criterion A
RF Field Susceptibility	EN61000-4-3, Level-3	Criterion A
Fast Transients/Bursts	EN61000-4-4, Level-3	Criterion B
Radiated Emissions	EN55022-B, CISPR22-B, FCC PART15-B	Criterion B
Surge Susceptibility	EN61000-4-5, Level-3	Criterion B
RF Immunity	EN61000-4-6, Level-3	Criterion A
Magnetic Fields	EN61000-4-8, Level-4	Criterion A
Voltage Interruptions	EN61000-4-11	Criterion B
Harmonic Current	EN61000-3-2, Level A	Criterion A
Voltage Fluctuations / Flicker	EN61000-3-3	
Vibration	Operating: Random vibration; 5 to 500 Hz (10 minutes, each axis).	Max. 2.4Grms
	Non-Operating: Random vibration; 5 to 500 Hz (10 minutes, each axis).	Max. 6Grms
Shock	Operating: half-sine, 11 ±3 mS 3-axis.	Max. 15G
	Non-Operating: half-sine, 11 ±3 mS 3-axis.	Max. 40G

## 9. Safety/Approvals

Maximum electric strength testing is performed in the factory according to IEC/EN 60950, UL 60950, CCC and BSMI. Input-to-output electric strength tests should not be repeated in the field. Bel Power Solutions will not honor any warranty claims resulting from electric strength field tests.

PARAMETER	DESCRIPTION / CONDITION	CRITERION
Agency Approvals	TUV, cCSAus, CCC, BSMI, CE (UL 60950-1 Second Edition CAN/CSA-C22.2 No. 60950-1-07 Second Edition IEC 60950-1:2005 EN 60950-1:2006 GB4943-2011)	Approved by independent body (see CE Declaration)
Isolation Strength	Input (L/N) to case (PE) Input (L/N) to output Output to case (PE)	Basic Reinforced Functional
Creepage / Clearance	Primary (L/N) to protective earth (PE) Primary to secondary	Min 4.0/2.5 mm Min 8/5 mm
Electrical Strength Test	Input to case Input to output Output and Signals to case	1840/2600 VAC/VDC 3000/4242 VAC/VDC 500 VDC

# ABC600 Series

## 10. Mechanical

PARAMETER	CONDITIONS/DESCRIPTION
Dimensions (L x W x H)	203.2 x 127 x 40.64 mm
Mounting	(Location/Hardware); Dimensions Drawing Figure 7
Input	Connector type: Molex 26-62-4056 or equivalent; (Location/Connector); Figure 7
Output	Connector type: M4 screw terminal; (Location/Connector); Figure 7
Signal	Connector type: AMTEK 2211MS-208GW-U; (Location/Connector); Figure 7
Outline Drawing Pins/Functions	See Mechanical Drawing/ Figure 7
Weight	0.9 kg (To be advised by engineering)
Mounting distance	Distance from top of the components (component side) to the customer's metal chassis – Natural cooling: 101.6 mm
	Distance from top of the components (component side) to the customer's metal chassis – Force cooling: 5 mm <sup>1</sup>

<sup>1</sup> 5 mm is not required if there is insulator between PSU and customer chassis.

CONNECTOR	PIN DESCRIPTION	HOUSING	CRIMP TERMINAL	WIRE GAUGE
J101	J101-1 = Live J101-2 = Live J101-3 = not fitted J101-4 = Neutral J101-5 = Neutral	Molex 09-50-3051 or equivalent	Molex 08-50-0105 or equivalent	AWG#18~16
J102	J102-1: A0 J102-2: A1 J102-3: SDA J102-4: SCL J102-5: SMB_ALERT_L J102-6: V1 <sub>share</sub> J102-7: V1_VS_SENSE J102-8: V1_VS_SENSE_RTN J102-9: SGND J102-10: V <sub>sb</sub> J102-11: +VP J102-12: PW_OK_H J102-13: INHIBIT_L J102-14: INHIBIT_L_RTN J102-15: V <sub>fan</sub> J102-16: SGND	AMTEK 2211MS-208GW-U or equivalent	AMTEK 2211H-208B-L or equivalent	AWG#22~26
J103	J103: EARTH	NA	Molex 19002-0024 or equivalent	AWG#16
Output terminal J106/J107	J107 = V1_VS_RTN J106 = V1_VS	NA	Molex 0190670067 or equivalent	AWG#6

## 11. Accessories

ITEM	DESCRIPTION	ORDERING PART NUMBER	SOURCE
	<b>I<sup>2</sup>C Utility</b> Windows XP/Vista/7 compatible GUI to program, control and monitor PET Front-Ends (and other I2C units)	N/A	<a href="http://www.belpowersolutions.com">www.belpowersolutions.com</a>

# ABC600 Series

Figure 7: Dimensions Drawing

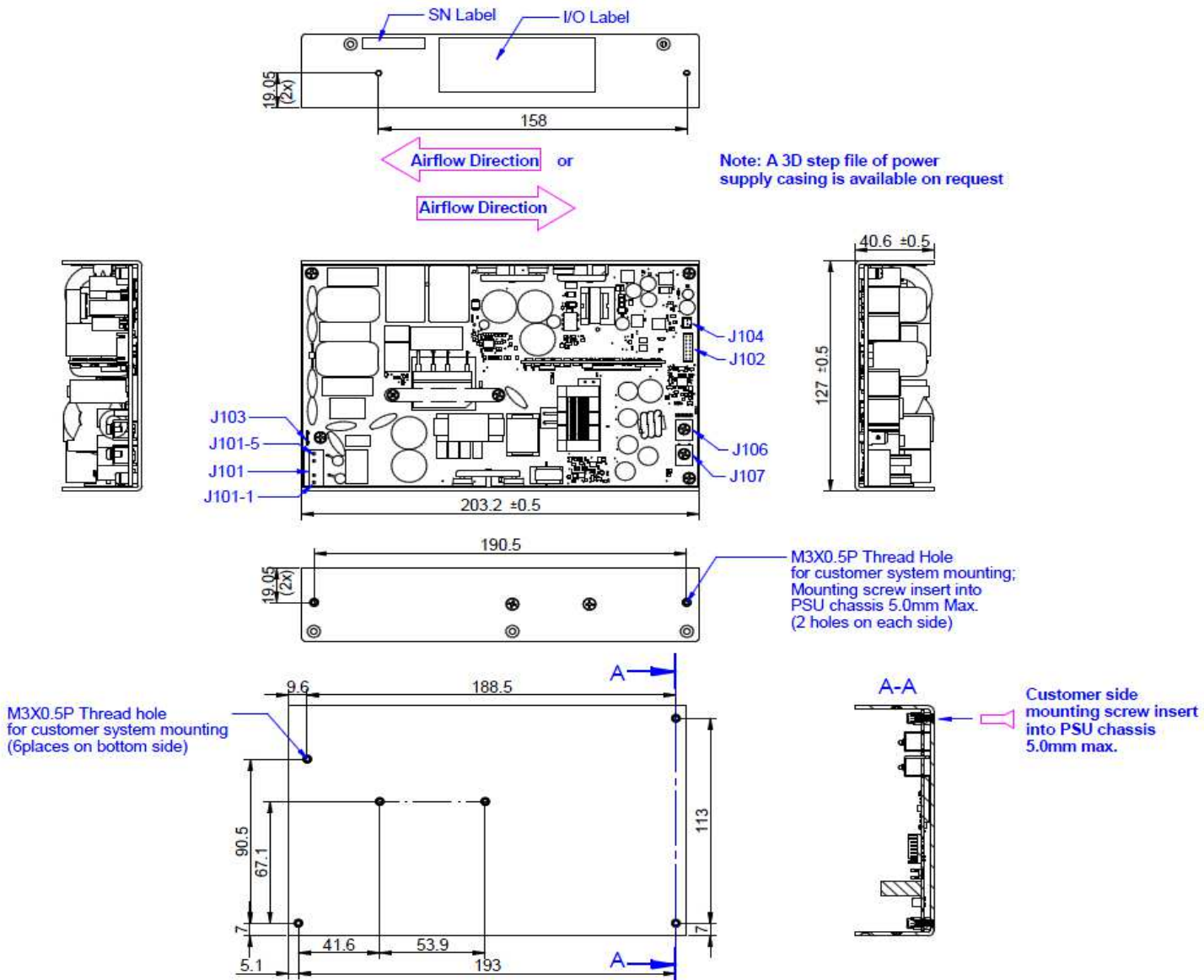

For more information on these products consult: [tech.support@psbel.com](mailto:tech.support@psbel.com)

**NUCLEAR AND MEDICAL APPLICATIONS** - Products are not designed or intended for use as critical components in life support systems, equipment used in hazardous environments, or nuclear control systems.

**TECHNICAL REVISIONS** - The appearance of products, including safety agency certifications pictured on labels, may change depending on the date manufactured. Specifications are subject to change without notice.



## Стандарт Электрон Связь

Мы молодая и активно развивающаяся компания в области поставок электронных компонентов. Мы поставляем электронные компоненты отечественного и импортного производства напрямую от производителей и с крупнейших складов мира.

Благодаря сотрудничеству с мировыми поставщиками мы осуществляем комплексные и плановые поставки широчайшего спектра электронных компонентов.

Собственная эффективная логистика и склад в обеспечивает надежную поставку продукции в точно указанные сроки по всей России.

Мы осуществляем техническую поддержку нашим клиентам и предпродажную проверку качества продукции. На все поставляемые продукты мы предоставляем гарантию .

Осуществляем поставки продукции под контролем ВП МО РФ на предприятия военно-промышленного комплекса России , а также работаем в рамках 275 ФЗ с открытием отдельных счетов в уполномоченном банке. Система менеджмента качества компании соответствует требованиям ГОСТ ISO 9001.

Минимальные сроки поставки, гибкие цены, неограниченный ассортимент и индивидуальный подход к клиентам являются основой для выстраивания долгосрочного и эффективного сотрудничества с предприятиями радиоэлектронной промышленности, предприятиями ВПК и научно-исследовательскими институтами России.

С нами вы становитесь еще успешнее!

### Наши контакты:

**Телефон:** +7 812 627 14 35

**Электронная почта:** [sales@st-electron.ru](mailto:sales@st-electron.ru)

**Адрес:** 198099, Санкт-Петербург,  
Промышленная ул, дом № 19, литера Н,  
помещение 100-Н Офис 331