

General Description

RFMD's QPA4563C is a high performance SiGe HBT MMIC amplifier utilizing a Darlington configuration with a patented active bias network. The active bias network provides stable current over temperature and process Beta variations. Designed to run directly from a 3V supply, the QPA4563C does not require a dropping resistor as compared to typical Darlington amplifiers. The QPA4563C is designed for high linearity 3V gain block applications that require small size and minimal external components. It is internally matched to 50 Ω .



6 Lead SOT-363 Package

Product Features

- Single Fixed 3V Supply
- No Dropping Resistor Required
- Patented Self-Bias Circuitry
- P1dB=+15.2dBm at 1950MHz
- OIP3=+27.8dBm at 1950MHz
- Robust 2000V ESD, Class 2 HBM

Functional Block Diagram

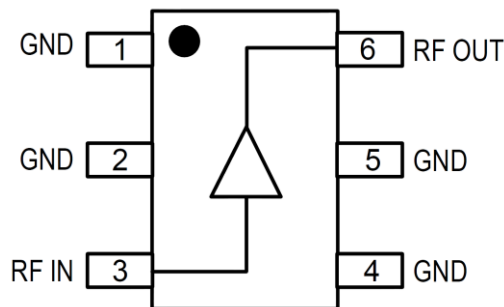

Top View

Applications

- Instrumentation
- Repeaters
- Boosters
- PA Driver Amplifier
- Cellular, PCS, GSM, UMTS
- IF Amplifier
- Wireless Data, Satellite

Ordering Information

| Part No. | Description |
|-----------------|--------------------------------------|
| QPA4563CTR7 | 3000 pieces on a 7" reel (standard) |
| QPA4563CSQ | 25 Piece Sample Bag |
| QPA4563CSR | 100 Pieces on 7" Reel |
| QPA4563CPCCK401 | 850 MHz, EVB with 5 Piece Sample Bag |

Absolute Maximum Ratings

| Parameter | Rating |
|----------------------------------|----------------|
| Storage Temp | -55 to +150 °C |
| Device Voltage (V _D) | +4 V |
| Device Current (I _D) | 110 mA |
| RF Input Power ⁽¹⁾ | +12 dBm |

Exceeding any one or a combination of the Absolute Maximum Rating conditions may cause permanent damage to the device. Extended application of Absolute Maximum Rating conditions to the device may reduce device reliability.

Notes:

1. Z_L to 10:1 VSWR

Electrical Specifications

| Parameter | Conditions | Min | Typ | Max | Units |
|-------------------------------------|------------|-------|-------|-----|-------|
| Small Signal Gain | 850 MHz | 20.0 | 23.6 | | dB |
| | 1950 MHz | 17.5 | 21.1 | | dB |
| | 2400 MHz | | 19.8 | | dB |
| Output Power at 1dB Compression | 850 MHz | | +15.8 | | dBm |
| | 1950 MHz | +13.0 | +15.2 | | dBm |
| | 2400 MHz | | +14.6 | | dBm |
| Output Third Intercept Point | 850 MHz | | +29.0 | | dBm |
| | 1950 MHz | +25.0 | +27.8 | | dBm |
| | 2400 MHz | | +26.6 | | dBm |
| Input Return Loss | 1950 MHz | | 16.3 | | dB |
| Output Return Loss | 1950 MHz | | 15.4 | | dB |
| Noise Figure | 1950 MHz | | 2.5 | 4.0 | dB |
| Device Operating Current | | | 48 | 60 | mA |
| Thermal Resistance, θ _{JC} | | | 126 | | °C/W |

Notes:

1. Test conditions unless otherwise noted: V_S = +3 V, I_D = 48 mA Typ., OIP3 Tone Spacing=1 MHz, P_{OUT} per tone = 0 dBm, 50 Ω system, Temp = +25 °C

Recommended Operating Conditions

| Parameter | Min | Typ | Max | Units |
|--|-----|------|------|-------|
| Operating Temperature | -40 | | +105 | °C |
| Junction Temperature (T _J) | | | +125 | °C |
| Device Operating Voltage | | +3.0 | | V |

Electrical specifications are measured at specified test conditions. Specifications are not guaranteed over all recommended operating conditions.

Evaluation Board and Schematic – 850 MHz Application Circuit

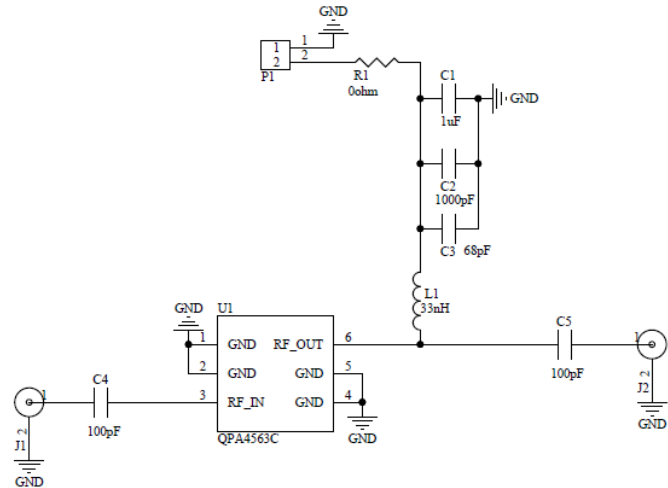

Bill of Material – 850 MHz Application Circuit

| Reference | Value | Description | Manufacturer | Part Number |
|-----------|---------|--|-----------------------|--------------------|
| n/a | n/a | PCB, QPA4563C | Qorvo | QPAXX63X-410(A) |
| C1 | 1 uF | CAP, 10%, 25V, X7R, 1206 | Murata Electronics | GRM31MR71E105KA01L |
| C2 | 1000 pF | CAP, 10%, 50V, X7R, 0402 | Murata Electronics | GRM155R71H102KA01D |
| C3 | 68 pF | CAP, 5%, 50V, C0G, 0402 | Murata Electronics | GRM1555C1H680JA01D |
| C4, C5 | 100 pF | CAP, 5%, 50V, C0G, 0402 | Murata Electronics | GRM1555C1H101JA01D |
| R1 | 0 Ω | RES, 0 Ω, 1210 | KOA Speer Electronics | RK73Z2ETTD |
| L1 | 33 nH | IND, 5%, M/L, 0603 | Murata Electronics | LL1608-FSL33NJ |
| J1, J2 | n/a | CONN, SMA, EL, FLT, 0.068" SPE-000318 | Amphenol RF Asia Corp | 901-10426 |
| U1 | n/a | HBT MMIC Amplifier | Qorvo | QPA4563C |
| J3, J4 | n/a | CONN, HDR, ST, 1x2, 0.100", Hi-temp, T/H | Samtec Inc | HTSW-102-07-G-S |

Component Values for Specific Frequencies

| Frequency | 500 MHz | 850 MHz | 1950 MHz | 2400 MHz | 3500 MHz |
|-----------|---------|---------|----------|----------|----------|
| C4, C5 | 220 pF | 100 pF | 68 pF | 56 pF | 39 pF |
| C3 | 100 pF | 68 pF | 22 pF | 22 pF | 15 pF |
| L1 | 68 nH | 33 nH | 22 nH | 18 nH | 15 nH |

Typical Performance – 850 MHz Application Circuit

| Parameter | Typical Value | | | | | Units |
|---------------------------------|---------------|-------|-------|-------|-------|-------|
| Frequency | 500 | 850 | 1950 | 2400 | 3500 | MHz |
| Small Signal Gain | 23.7 | 23.6 | 21.1 | 19.8 | 16.9 | dB |
| Output Third Intercept Point | +28.6 | +29.0 | +27.8 | +26.6 | +24.8 | dBm |
| Output Power at 1dB Compression | +16.2 | +15.8 | +15.2 | +14.6 | +13.8 | dBm |
| Input Return Loss | 17.2 | 17.2 | 16.3 | 15.8 | 13.8 | dB |
| Output Return Loss | 13.5 | 21.3 | 15.4 | 13.8 | 14.6 | dB |
| Reverse Isolation | 26.5 | 26.7 | 25.7 | 24.9 | 23.0 | dB |
| Noise Figure | 2.3 | 2.2 | 2.5 | 2.7 | 3.3 | dB |

Notes:

1. Test conditions: $V_s = +3\text{ V}$, $I_D = 48\text{ mA Typ.}$, OIP3 Tone Spacing=1 MHz, P_{OUT} per tone = 0 dBm, 50 Ω system, Temp = +25 °C

Performance Plots – 850 MHz Application Circuit

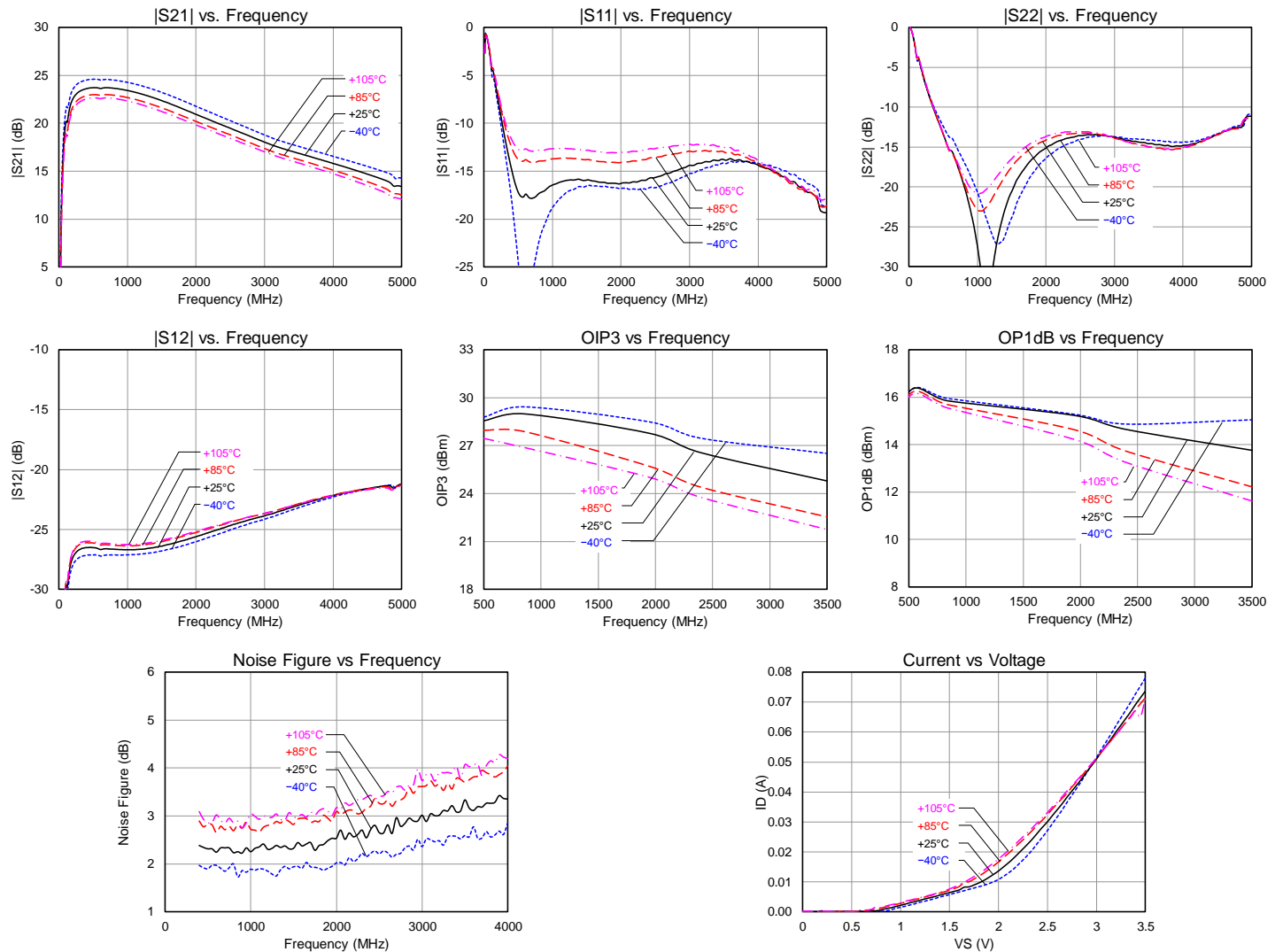
 Test conditions unless otherwise noted: $V_s = +3.0\text{ V}$, $I_D = 48\text{ mA}$, Temp.= +25 °C

Pin Configuration and Description

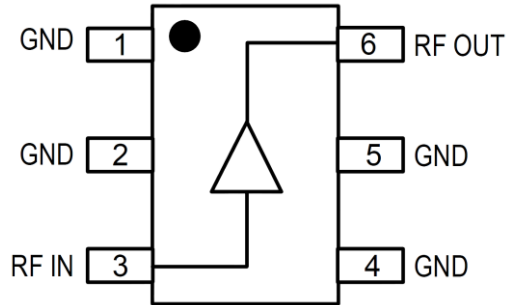

Top View

| Pad No. | Label | Description |
|------------|-------------------|---|
| 1, 2, 4, 5 | GND | Connection to ground. Use via holes in PCB for best performance to reduce lead inductance as close to ground leads as possible |
| 3 | RF _{IN} | RF Input Pin. This pin requires the use of an external DC blocking capacitor chosen for the frequency of operation. |
| 6 | RF _{OUT} | RF Output and Bias Pin. DC voltage is present on this pin, therefore a DC blocking capacitor is necessary for proper operation. |

Package Marking

Trace Code - XXXX

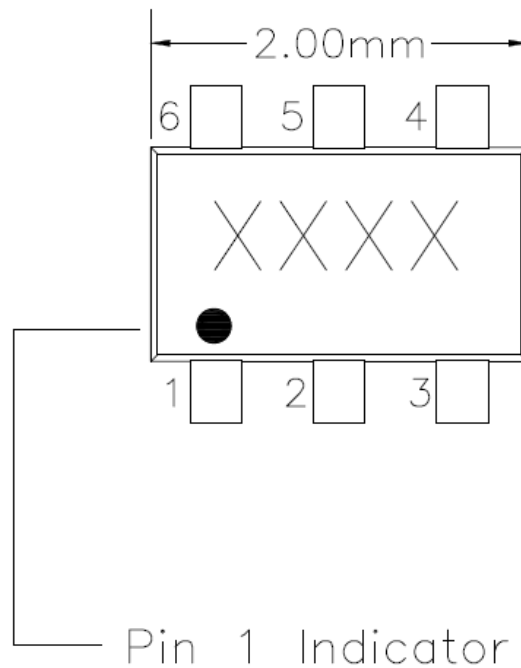

Package Dimensions

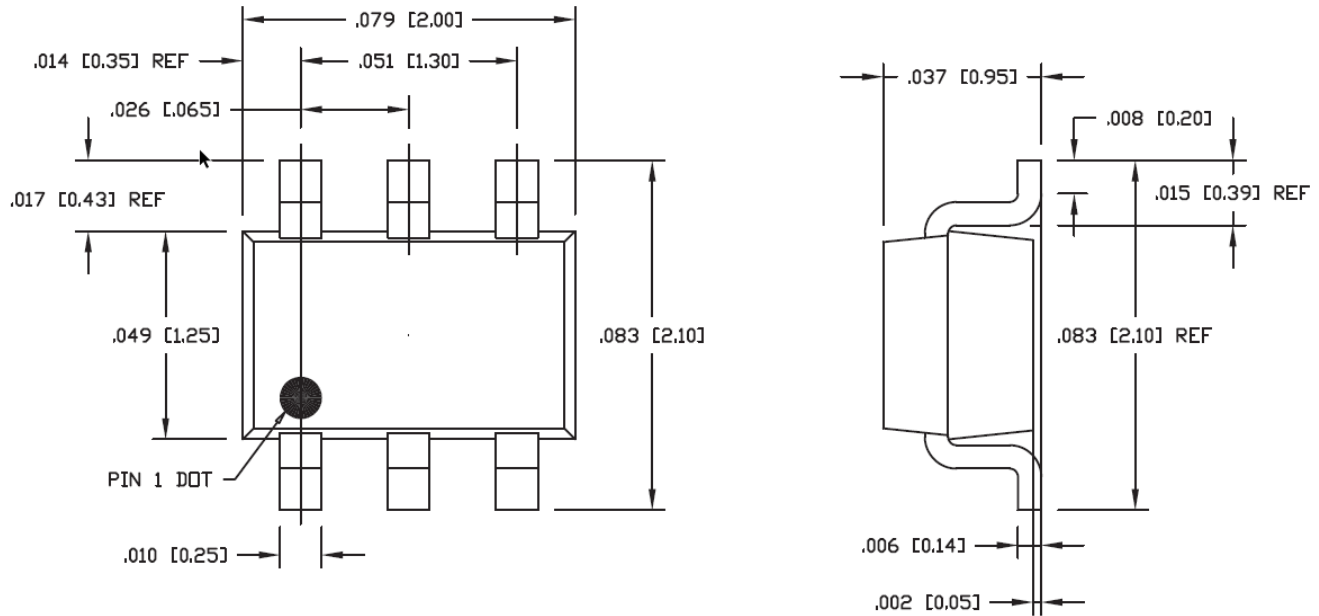

- Notes:
1. All dimensions are in inches (millimeters). Angles are in degrees.
 2. Dimension and tolerance formats conform to ASME Y15.5-2009.

PCB Mounting Pattern

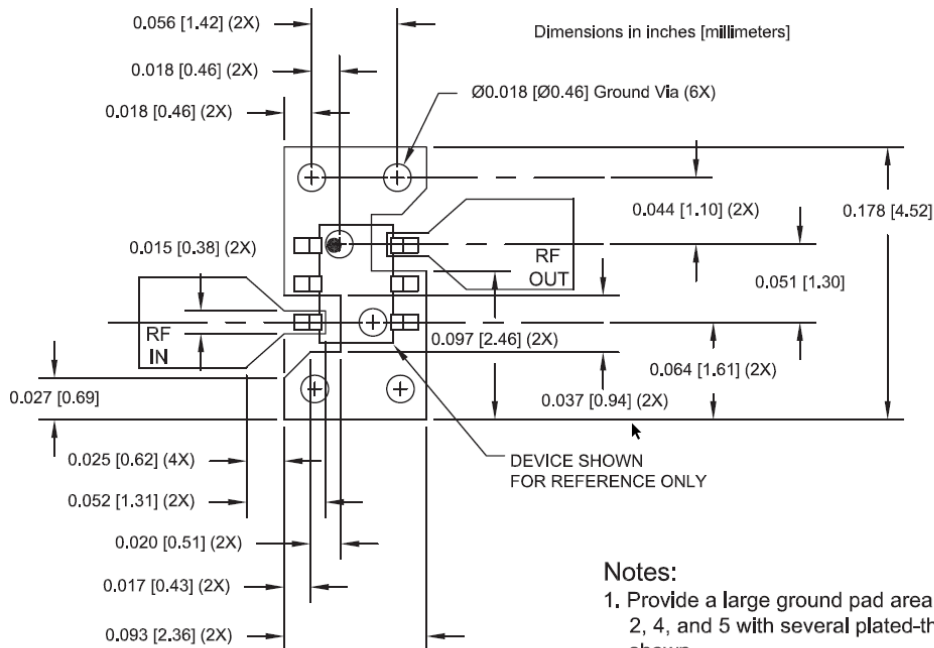

- Notes:
1. Provide a large ground pad area under device pins 1, 2, 4, and 5 with several plated-through holes placed as shown.
 2. 1/2 ounce finished copper thickness is recommended.
 3. RF I/O lines are 50Ω

- Notes:
1. All dimensions are in inches (millimeters). Angles are in degrees.

Handling Precautions

| Parameter | Rating | Standard |
|----------------------------------|----------|--------------------------|
| ESD – Human Body Model (HBM) | Class 2 | ESDA / JEDEC JS-001-2014 |
| ESD – Charged Device Model (CDM) | Class C3 | ESDA / JEDEC JS-002-2014 |
| MSL – Moisture Sensitivity Level | Level 1 | IPC/JEDEC J-STD-020 |



Caution!
ESD-Sensitive Device

Solderability

Compatible with lead-free (260°C max. reflow temp.) soldering process.

Solder profiles available upon request.

Contact plating: Matte Sn

RoHS Compliance

This part is compliant with 2011/65/EU RoHS directive (Restrictions on the Use of Certain Hazardous Substances in Electrical and Electronic Equipment) as amended by Directive 2015/863/EU.

This product also has the following attributes:

- Lead Free
- Halogen Free (Chlorine, Bromine)
- Antimony Free
- TBBP-A (C₁₅H₁₂Br₄O₂) Free
- PFOS Free
- SVHC Free



Contact Information

For the latest specifications, additional product information, worldwide sales and distribution locations:

Web: www.qorvo.com

Tel: 1-844-890-8163

Email: customer.support@qorvo.com

For technical questions and application information:

Email: appsupport@qorvo.com

Important Notice

The information contained herein is believed to be reliable; however, Qorvo makes no warranties regarding the information contained herein and assumes no responsibility or liability whatsoever for the use of the information contained herein. All information contained herein is subject to change without notice. Customers should obtain and verify the latest relevant information before placing orders for Qorvo products. The information contained herein or any use of such information does not grant, explicitly or implicitly, to any party any patent rights, licenses, or any other intellectual property rights, whether with regard to such information itself or anything described by such information. **THIS INFORMATION DOES NOT CONSTITUTE A WARRANTY WITH RESPECT TO THE PRODUCTS DESCRIBED HEREIN, AND QORVO HEREBY DISCLAIMS ANY AND ALL WARRANTIES WITH RESPECT TO SUCH PRODUCTS WHETHER EXPRESS OR IMPLIED BY LAW, COURSE OF DEALING, COURSE OF PERFORMANCE, USAGE OF TRADE OR OTHERWISE, INCLUDING THE IMPLIED WARRANTIES OF MERCHANTABILITY AND FITNESS FOR A PARTICULAR PURPOSE.**

Without limiting the generality of the foregoing, Qorvo products are not warranted or authorized for use as critical components in medical, life-saving, or life-sustaining applications, or other applications where a failure would reasonably be expected to cause severe personal injury or death.

Copyright 2018 © Qorvo, Inc. | Qorvo is a registered trademark of Qorvo, Inc.



Стандарт Электрон Связь

Мы молодая и активно развивающаяся компания в области поставок электронных компонентов. Мы поставляем электронные компоненты отечественного и импортного производства напрямую от производителей и с крупнейших складов мира.

Благодаря сотрудничеству с мировыми поставщиками мы осуществляем комплексные и плановые поставки широчайшего спектра электронных компонентов.

Собственная эффективная логистика и склад в обеспечивает надежную поставку продукции в точно указанные сроки по всей России.

Мы осуществляем техническую поддержку нашим клиентам и предпродажную проверку качества продукции. На все поставляемые продукты мы предоставляем гарантию .

Осуществляем поставки продукции под контролем ВП МО РФ на предприятия военно-промышленного комплекса России , а также работаем в рамках 275 ФЗ с открытием отдельных счетов в уполномоченном банке. Система менеджмента качества компании соответствует требованиям ГОСТ ISO 9001.

Минимальные сроки поставки, гибкие цены, неограниченный ассортимент и индивидуальный подход к клиентам являются основой для выстраивания долгосрочного и эффективного сотрудничества с предприятиями радиоэлектронной промышленности, предприятиями ВПК и научно-исследовательскими институтами России.

С нами вы становитесь еще успешнее!

Наши контакты:

Телефон: +7 812 627 14 35

Электронная почта: sales@st-electron.ru

Адрес: 198099, Санкт-Петербург,
Промышленная ул, дом № 19, литера Н,
помещение 100-Н Офис 331