

## 1M x 8 HIGH-SPEED CMOS STATIC RAM

JUNE 2008

### FEATURES

- High-speed access times:  
8, 10, 20 ns
- High-performance, low-power CMOS process
- Multiple center power and ground pins for greater noise immunity
- Easy memory expansion with  $\overline{CE}$  and  $\overline{OE}$  options
- $\overline{CE}$  power-down
- Fully static operation: no clock or refresh required
- TTL compatible inputs and outputs
- Single power supply
  - $V_{DD}$  1.65V to 2.2V (IS61WV10248ALL)  
speed = 20ns for  $V_{cc} = 1.65V$  to 2.2V
  - $V_{DD}$  2.4V to 3.6V (IS61/64WV10248BLL)  
speed = 10ns for  $V_{cc} = 2.4V$  to 3.6V  
speed = 8ns for  $V_{cc} = 3.3V \pm 5\%$
- Packages available:
  - 48-ball miniBGA (9mm x 11mm)
  - 44-pin TSOP (Type II)
- Industrial and Automotive Temperature Support
- Lead-free available

### DESCRIPTION

The *ISSI* IS61WV10248ALL/BLL and IS64WV10248BLL are very high-speed, low power, 1M-word by 8-bit CMOS static RAM. The IS61WV10248ALL/BLL and IS64WV10248BLL are fabricated using *ISSI*'s high-performance CMOS technology. This highly reliable process coupled with innovative circuit design techniques, yields higher performance and low power consumption devices.

When  $\overline{CE}$  is HIGH (deselected), the device assumes a standby mode at which the power dissipation can be reduced down with CMOS input levels.

The IS61WV10248ALL/BLL and IS64WV10248BLL operate from a single power supply and all inputs are TTL-compatible.

The IS61WV10248ALL/BLL and IS64WV10248BLL are available in 48 ball mini BGA and 44-pin TSOP (Type II) packages.

### FUNCTIONAL BLOCK DIAGRAM

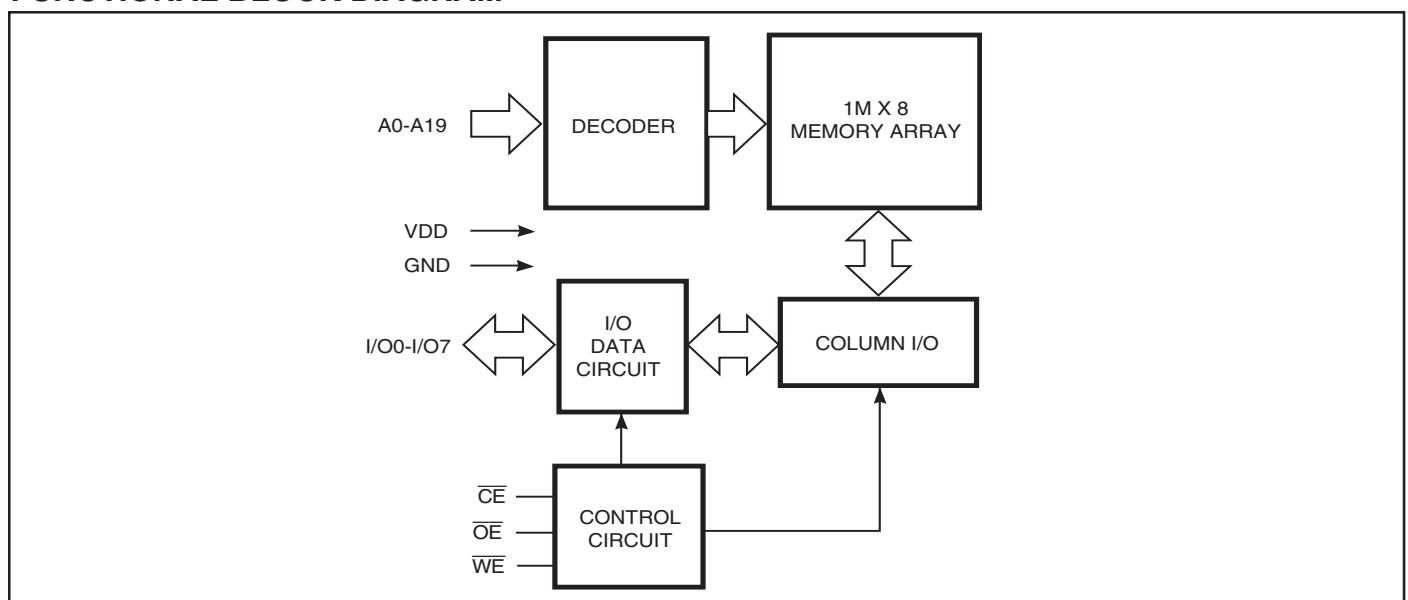

Copyright © 2006 Integrated Silicon Solution, Inc. All rights reserved. ISSI reserves the right to make changes to this specification and its products at any time without notice. ISSI assumes no liability arising out of the application or use of any information, products or services described herein. Customers are advised to obtain the latest version of this device specification before relying on any published information and before placing orders for products.

## PIN CONFIGURATION

### 48-pin Mini BGA (M ) (9mm x 11mm)

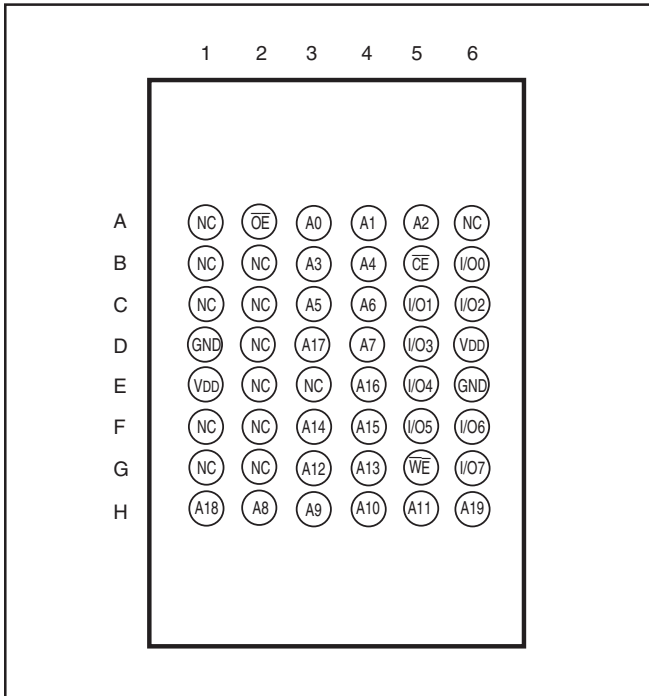

### 44-pin TSOP (Type II )

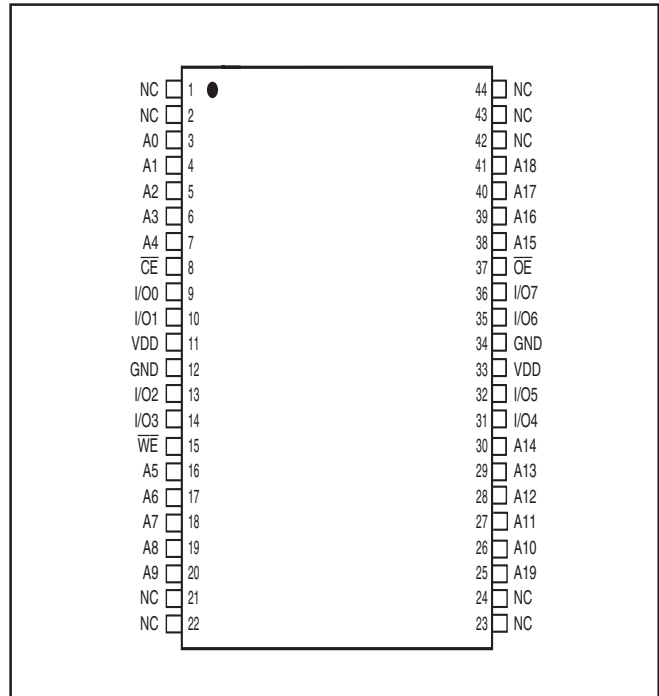

## PIN DESCRIPTIONS

A0-A19	Address Inputs
CE	Chip Enable Input
OE	Output Enable Input
WE	Write Enable Input
I/O0-I/O7	Data Input / Output
VDD	Power
GND	Ground
NC	No Connection

## TRUTH TABLE

Mode	$\overline{WE}$	$\overline{CE}$	$\overline{OE}$	I/O Operation	V <sub>DD</sub> Current
Not Selected (Power-down)	X	H	X	High-Z	I <sub>SB1</sub> , I <sub>SB2</sub>
Output Disabled	H	L	H	High-Z	I <sub>CC</sub>
Read	H	L	L	D <sub>OUT</sub>	I <sub>CC</sub>
Write	L	L	X	D <sub>IN</sub>	I <sub>CC</sub>

## ABSOLUTE MAXIMUM RATINGS<sup>(1)</sup>

Symbol	Parameter	Value	Unit
V <sub>TERM</sub>	Terminal Voltage with Respect to GND	-0.5 to V <sub>DD</sub> + 0.5	V
V <sub>DD</sub>	V <sub>DD</sub> Relates to GND	-0.3 to 4.0	V
T <sub>STG</sub>	Storage Temperature	-65 to +150	°C
P <sub>T</sub>	Power Dissipation	1.0	W

### Notes:

1. Stress greater than those listed under ABSOLUTE MAXIMUM RATINGS may cause permanent damage to the device. This is a stress rating only and functional operation of the device at these or any other conditions above those indicated in the operational sections of this specification is not implied. Exposure to absolute maximum rating conditions for extended periods may affect reliability.

## CAPACITANCE<sup>(1,2)</sup>

Symbol	Parameter	Conditions	Max.	Unit
C <sub>IN</sub>	Input Capacitance	V <sub>IN</sub> = 0V	6	pF
C <sub>I/O</sub>	Input/Output Capacitance	V <sub>OUT</sub> = 0V	8	pF

### Notes:

1. Tested initially and after any design or process changes that may affect these parameters.
2. Test conditions: T<sub>A</sub> = 25°C, f = 1 MHz, V<sub>DD</sub> = 3.3V.

### OPERATING RANGE (V<sub>DD</sub>) (IS61WV10248ALL)

Range	Ambient Temperature	V <sub>DD</sub> (20 ns)
Commercial	0°C to +70°C	1.65V-2.2V
Industrial	-40°C to +85°C	1.65V-2.2V
Automotive	-40°C to +125°C	1.65V-2.2V

### OPERATING RANGE (V<sub>DD</sub>) (IS61WV10248BLL)<sup>(1)</sup>

Range	Ambient Temperature	V <sub>DD</sub> (8 ns)	V <sub>DD</sub> (10 ns)
Commercial	0°C to +70°C	3.3V ± 5%	2.4V-3.6V
Industrial	-40°C to +85°C	3.3V ± 5%	2.4V-3.6V

**Note:**

1. When operated in the range of 2.4V-3.6V, the device meets 10ns. When operated in the range of 3.3V ± 5%, the device meets 8ns.

### OPERATING RANGE (V<sub>DD</sub>) (IS64WV10248BLL)

Range	Ambient Temperature	V <sub>DD</sub> (10 ns)
Automotive	-40°C to +125°C	2.4V-3.6V

**DC ELECTRICAL CHARACTERISTICS** (Over Operating Range)

**V<sub>DD</sub> = 3.3V ± 5%**

Symbol	Parameter	Test Conditions	Min.	Max.	Unit
V <sub>OH</sub>	Output HIGH Voltage	V <sub>DD</sub> = Min., I <sub>OH</sub> = -4.0 mA	2.4	—	V
V <sub>OL</sub>	Output LOW Voltage	V <sub>DD</sub> = Min., I <sub>OL</sub> = 8.0 mA	—	0.4	V
V <sub>IH</sub>	Input HIGH Voltage		2	V <sub>DD</sub> + 0.3	V
V <sub>IL</sub>	Input LOW Voltage <sup>(1)</sup>		-0.3	0.8	V
I <sub>LI</sub>	Input Leakage	GND ≤ V <sub>IN</sub> ≤ V <sub>DD</sub>	-1	1	μA
I <sub>LO</sub>	Output Leakage	GND ≤ V <sub>OUT</sub> ≤ V <sub>DD</sub> , Outputs Disabled	-1	1	μA

**Note:**

- V<sub>IL</sub>(min.) = -0.3V DC; V<sub>IL</sub>(min.) = -2.0V AC (pulse width ≤ 10 ns). Not 100% tested.  
 V<sub>IH</sub>(max.) = V<sub>DD</sub> + 0.3V DC; V<sub>IH</sub>(max.) = V<sub>DD</sub> + 2.0V AC (pulse width ≤ 10 ns). Not 100% tested.

**DC ELECTRICAL CHARACTERISTICS** (Over Operating Range)

**V<sub>DD</sub> = 2.4V-3.6V**

Symbol	Parameter	Test Conditions	Min.	Max.	Unit
V <sub>OH</sub>	Output HIGH Voltage	V <sub>DD</sub> = Min., I <sub>OH</sub> = -1.0 mA	1.8	—	V
V <sub>OL</sub>	Output LOW Voltage	V <sub>DD</sub> = Min., I <sub>OL</sub> = 1.0 mA	—	0.4	V
V <sub>IH</sub>	Input HIGH Voltage		2.0	V <sub>DD</sub> + 0.3	V
V <sub>IL</sub>	Input LOW Voltage <sup>(1)</sup>		-0.3	0.8	V
I <sub>LI</sub>	Input Leakage	GND ≤ V <sub>IN</sub> ≤ V <sub>DD</sub>	-1	1	μA
I <sub>LO</sub>	Output Leakage	GND ≤ V <sub>OUT</sub> ≤ V <sub>DD</sub> , Outputs Disabled	-1	1	μA

**Note:**

- V<sub>IL</sub>(min.) = -0.3V DC; V<sub>IL</sub>(min.) = -2.0V AC (pulse width ≤ 10 ns). Not 100% tested.  
 V<sub>IH</sub>(max.) = V<sub>DD</sub> + 0.3V DC; V<sub>IH</sub>(max.) = V<sub>DD</sub> + 2.0V AC (pulse width ≤ 10 ns). Not 100% tested.

**DC ELECTRICAL CHARACTERISTICS** (Over Operating Range)

**V<sub>DD</sub> = 1.65V-2.2V**

Symbol	Parameter	Test Conditions	V <sub>DD</sub>	Min.	Max.	Unit
V <sub>OH</sub>	Output HIGH Voltage	I <sub>OH</sub> = -0.1 mA	1.65-2.2V	1.4	—	V
V <sub>OL</sub>	Output LOW Voltage	I <sub>OL</sub> = 0.1 mA	1.65-2.2V	—	0.2	V
V <sub>IH</sub>	Input HIGH Voltage		1.65-2.2V	1.4	V <sub>DD</sub> + 0.2	V
V <sub>IL</sub> <sup>(1)</sup>	Input LOW Voltage		1.65-2.2V	-0.2	0.4	V
I <sub>LI</sub>	Input Leakage	GND ≤ V <sub>IN</sub> ≤ V <sub>DD</sub>		-1	1	μA
I <sub>LO</sub>	Output Leakage	GND ≤ V <sub>OUT</sub> ≤ V <sub>DD</sub> , Outputs Disabled		-1	1	μA

**Note:**

- V<sub>IL</sub>(min.) = -0.3V DC; V<sub>IL</sub>(min.) = -2.0V AC (pulse width ≤ 10 ns). Not 100% tested.  
 V<sub>IH</sub>(max.) = V<sub>DD</sub> + 0.3V DC; V<sub>IH</sub>(max.) = V<sub>DD</sub> + 2.0V AC (pulse width ≤ 10 ns). Not 100% tested.

### AC TEST CONDITIONS (HIGH SPEED)

Parameter	Unit (2.4V-3.6V)	Unit (3.3V ± 5%)	Unit (1.65V-2.2V)
Input Pulse Level	0.4V to $V_{DD}-0.3V$	0.4V to $V_{DD}-0.3V$	0.4V to $V_{DD}-0.2V$
Input Rise and Fall Times	1.5ns	1.5ns	1.5ns
Input and Output Timing and Reference Level ( $V_{Ref}$ )	$V_{DD}/2$	$V_{DD}/2 + 0.05$	$V_{DD}/2$
Output Load	See Figures 1 and 2	See Figures 1 and 2	See Figures 1 and 2

### AC TEST LOADS



Figure 1.

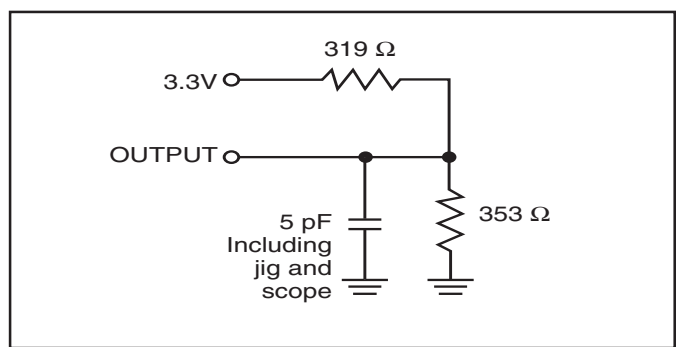

Figure 2.

**POWER SUPPLY CHARACTERISTICS<sup>(1)</sup>** (Over Operating Range)

Symbol	Parameter	Test Conditions		-8		-10		-20		Unit
				Min.	Max.	Min.	Max.	Min.	Max.	
I <sub>CC</sub>	V <sub>DD</sub> Dynamic Operating Supply Current	V <sub>DD</sub> = Max., I <sub>OUT</sub> = 0 mA, f = f <sub>MAX</sub>	Com.	—	110	—	95	—	90	mA
			Ind.	—	120	—	100	—	100	
			Auto.	—	—	—	140	—	140	
			typ. <sup>(2)</sup>			60				
I <sub>CC1</sub>	Operating Supply Current	V <sub>DD</sub> = Max., I <sub>OUT</sub> = 0 mA, f = 0	Com.	—	30	—	30	—	30	mA
			Ind.	—	35	—	35	—	35	
			Auto.	—	—	—	60	—	70	
I <sub>SB1</sub>	TTL Standby Current (TTL Inputs)	V <sub>DD</sub> = Max., V <sub>IN</sub> = V <sub>IH</sub> or V <sub>IL</sub> $\overline{CE} \geq V_{IH}$ , f = 0	Com.	—	30	—	30	—	30	mA
			Ind.	—	35	—	35	—	35	
			Auto.	—	—	—	70	—	70	
I <sub>SB2</sub>	CMOS Standby Current (CMOS Inputs)	V <sub>DD</sub> = Max., $\overline{CE} \geq V_{DD} - 0.2V$ , V <sub>IN</sub> ≥ V <sub>DD</sub> - 0.2V, or V <sub>IN</sub> ≤ 0.2V, f = 0	Com.	—	20	—	20	—	15	mA
			Ind.	—	25	—	25	—	20	
			Auto.	—	—	—	70	—	70	
			typ. <sup>(2)</sup>			4				

**Note:**

1. At f = f<sub>MAX</sub>, address and data inputs are cycling at the maximum frequency, f = 0 means no input lines change.
2. Typical values are measured at V<sub>DD</sub> = 3.0V, T<sub>A</sub> = 25°C and not 100% tested.

**READ CYCLE SWITCHING CHARACTERISTICS<sup>(1)</sup>** (Over Operating Range)

Symbol	Parameter	-8		-10		Unit
		Min.	Max.	Min.	Max.	
t <sub>RC</sub>	Read Cycle Time	8	—	10	—	ns
t <sub>AA</sub>	Address Access Time	—	8	—	10	ns
t <sub>CHA</sub>	Output Hold Time	2	—	2	—	ns
t <sub>ACE</sub>	$\overline{\text{CE}}$ Access Time	—	8	—	10	ns
t <sub>DOE</sub>	$\overline{\text{OE}}$ Access Time	—	5.5	—	6.5	ns
t <sub>HZOE<sup>(2)</sup></sub>	$\overline{\text{OE}}$ to High-Z Output	—	3	—	4	ns
t <sub>LZOE<sup>(2)</sup></sub>	$\overline{\text{OE}}$ to Low-Z Output	0	—	0	—	ns
t <sub>HZCE<sup>(2)</sup></sub>	$\overline{\text{CE}}$ to High-Z Output	0	3	0	4	ns
t <sub>LZCE<sup>(2)</sup></sub>	$\overline{\text{CE}}$ to Low-Z Output	3	—	3	—	ns
t <sub>PU</sub>	Power Up Time	0	—	0	—	ns
t <sub>PD</sub>	Power Down Time	—	8	—	10	ns

**Notes:**

1. Test conditions assume signal transition times of 3 ns or less, timing reference levels of 1.5V, input pulse levels of 0V to 3.0V and output loading specified in Figure 1.
2. Tested with the load in Figure 2. Transition is measured  $\pm 500$  mV from steady-state voltage.



**READ CYCLE SWITCHING CHARACTERISTICS<sup>(1)</sup>** (Over Operating Range)

Symbol	Parameter	-20 ns		Unit
		Min.	Max.	
t <sub>RC</sub>	Read Cycle Time	20	—	ns
t <sub>AA</sub>	Address Access Time	—	20	ns
t <sub>OHA</sub>	Output Hold Time	2.5	—	ns
t <sub>ACE</sub>	$\overline{\text{CE}}$ Access Time	—	20	ns
t <sub>DOE</sub>	$\overline{\text{OE}}$ Access Time	—	8	ns
t <sub>HZOE<sup>(2)</sup></sub>	$\overline{\text{OE}}$ to High-Z Output	0	8	ns
t <sub>LZOE<sup>(2)</sup></sub>	$\overline{\text{OE}}$ to Low-Z Output	0	—	ns
t <sub>HZCE<sup>(2)</sup></sub>	$\overline{\text{CE}}$ to High-Z Output	0	8	ns
t <sub>LZCE<sup>(2)</sup></sub>	$\overline{\text{CE}}$ to Low-Z Output	3	—	ns
t <sub>PU</sub>	Power Up Time	0	—	ns
t <sub>PD</sub>	Power Down Time	—	20	ns

**Notes:**

1. Test conditions assume signal transition times of 1.5 ns or less, timing reference levels of 1.25V, input pulse levels of 0.4V to V<sub>DD</sub>-0.3V and output loading specified in Figure 1.
2. Tested with the load in Figure 2. Transition is measured ±500 mV from steady-state voltage. Not 100% tested.
3. Not 100% tested.

**AC WAVEFORMS**

**READ CYCLE NO. 1<sup>(1,2)</sup>** (Address Controlled) ( $\overline{CE} = \overline{OE} = V_{IL}$ )

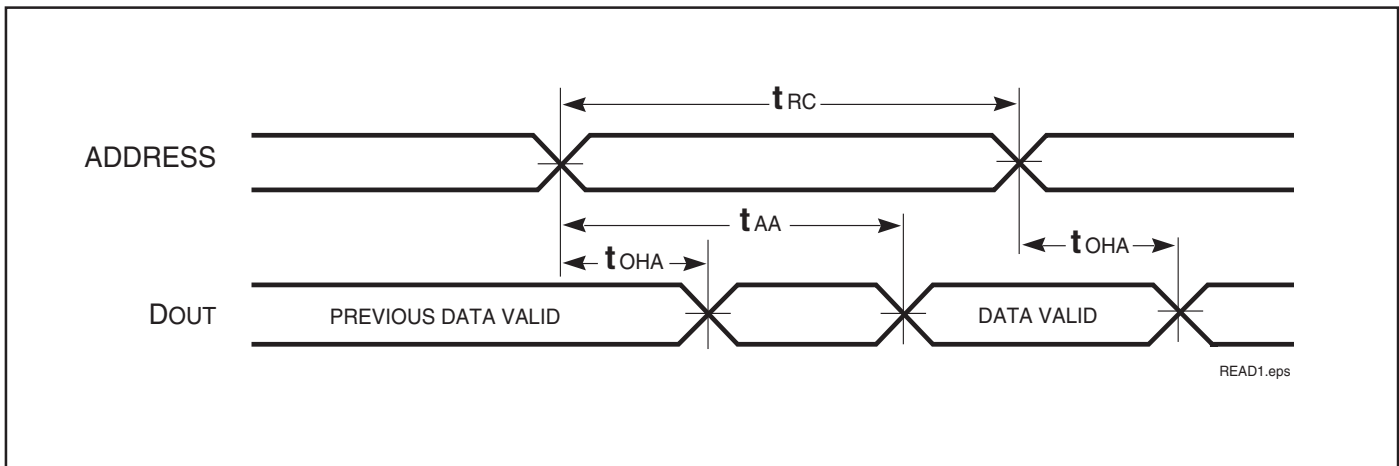

**READ CYCLE NO. 2<sup>(1,3)</sup>** ( $\overline{CE}$  and  $\overline{OE}$  Controlled)

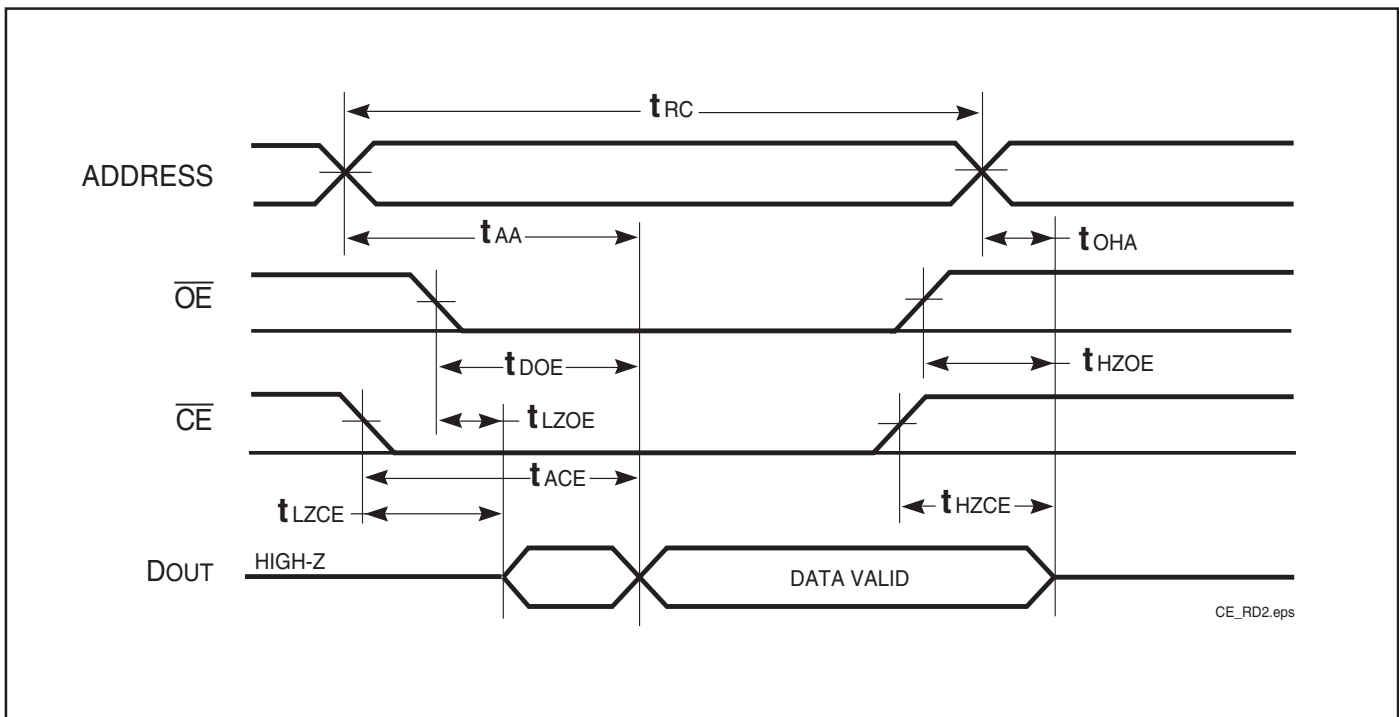

**Notes:**

1.  $\overline{WE}$  is HIGH for a Read Cycle.
2. The device is continuously selected.  $\overline{OE}$ ,  $\overline{CE} = V_{IL}$ .
3. Address is valid prior to or coincident with  $\overline{CE}$  LOW transitions.

**WRITE CYCLE SWITCHING CHARACTERISTICS<sup>(1,3)</sup>** (Over Operating Range)

Symbol	Parameter	-8		-10		Unit
		Min.	Max.	Min.	Max.	
t <sub>WC</sub>	Write Cycle Time	8	—	10	—	ns
t <sub>SCE</sub>	$\overline{CE}$ to Write End	6.5	—	8	—	ns
t <sub>AW</sub>	Address Setup Time to Write End	6.5	—	8	—	ns
t <sub>HA</sub>	Address Hold from Write End	0	—	0	—	ns
t <sub>SA</sub>	Address Setup Time	0	—	0	—	ns
t <sub>PWE1</sub>	$\overline{WE}$ Pulse Width ( $\overline{OE}$ = HIGH)	6.5	—	8	—	ns
t <sub>PWE2</sub>	$\overline{WE}$ Pulse Width ( $\overline{OE}$ = LOW)	8.0	—	10	—	ns
t <sub>SD</sub>	Data Setup to Write End	5	—	6	—	ns
t <sub>HD</sub>	Data Hold from Write End	0	—	0	—	ns
t <sub>HZWE<sup>(2)</sup></sub>	$\overline{WE}$ LOW to High-Z Output	—	3.5	—	5	ns
t <sub>LZWE<sup>(2)</sup></sub>	$\overline{WE}$ HIGH to Low-Z Output	2	—	2	—	ns

**Notes:**

1. Test conditions assume signal transition times of 3 ns or less, timing reference levels of 1.5V, input pulse levels of 0V to 3.0V and output loading specified in Figure 1.
2. Tested with the load in Figure 2. Transition is measured  $\pm 500$  mV from steady-state voltage. Not 100% tested.
3. The internal write time is defined by the overlap of  $\overline{CE}$  LOW and  $\overline{WE}$  LOW. All signals must be in valid states to initiate a Write, but any one can go inactive to terminate the Write. The Data Input Setup and Hold timing are referenced to the rising or falling edge of the signal that terminates the write. Shaded area product in development

**WRITE CYCLE SWITCHING CHARACTERISTICS<sup>(1,2)</sup>** (Over Operating Range)

Symbol	Parameter	-20 ns		Unit
		Min.	Max.	
t <sub>WC</sub>	Write Cycle Time	20	—	ns
t <sub>SCE</sub>	$\overline{CE}$ to Write End	12	—	ns
t <sub>AW</sub>	Address Setup Time to Write End	12	—	ns
t <sub>HA</sub>	Address Hold from Write End	0	—	ns
t <sub>SA</sub>	Address Setup Time	0	—	ns
t <sub>PWE1</sub>	$\overline{WE}$ Pulse Width ( $\overline{OE}$ = HIGH)	12	—	ns
t <sub>PWE2</sub>	$\overline{WE}$ Pulse Width ( $\overline{OE}$ = LOW)	17	—	ns
t <sub>SD</sub>	Data Setup to Write End	9	—	ns
t <sub>HD</sub>	Data Hold from Write End	0	—	ns
t <sub>HZWE<sup>(3)</sup></sub>	$\overline{WE}$ LOW to High-Z Output	—	9	ns
t <sub>LZWE<sup>(3)</sup></sub>	$\overline{WE}$ HIGH to Low-Z Output	3	—	ns

**Notes:**

1. Test conditions assume signal transition times of 1.5ns or less, timing reference levels of 1.25V, input pulse levels of 0.4V to V<sub>DD</sub>-0.3V and output loading specified in Figure 1.
2. Tested with the load in Figure 2. Transition is measured ±500 mV from steady-state voltage. Not 100% tested.
3. The internal write time is defined by the overlap of  $\overline{CE}$  LOW and  $\overline{WE}$  LOW. All signals must be in valid states to initiate a Write, but any one can go inactive to terminate the Write. The Data Input Setup and Hold timing are referenced to the rising or falling edge of the signal that terminates the write.

**AC WAVEFORMS**

**WRITE CYCLE NO. 1**<sup>(1,2)</sup> ( $\overline{CE}$  Controlled,  $\overline{OE}$  = HIGH or LOW)

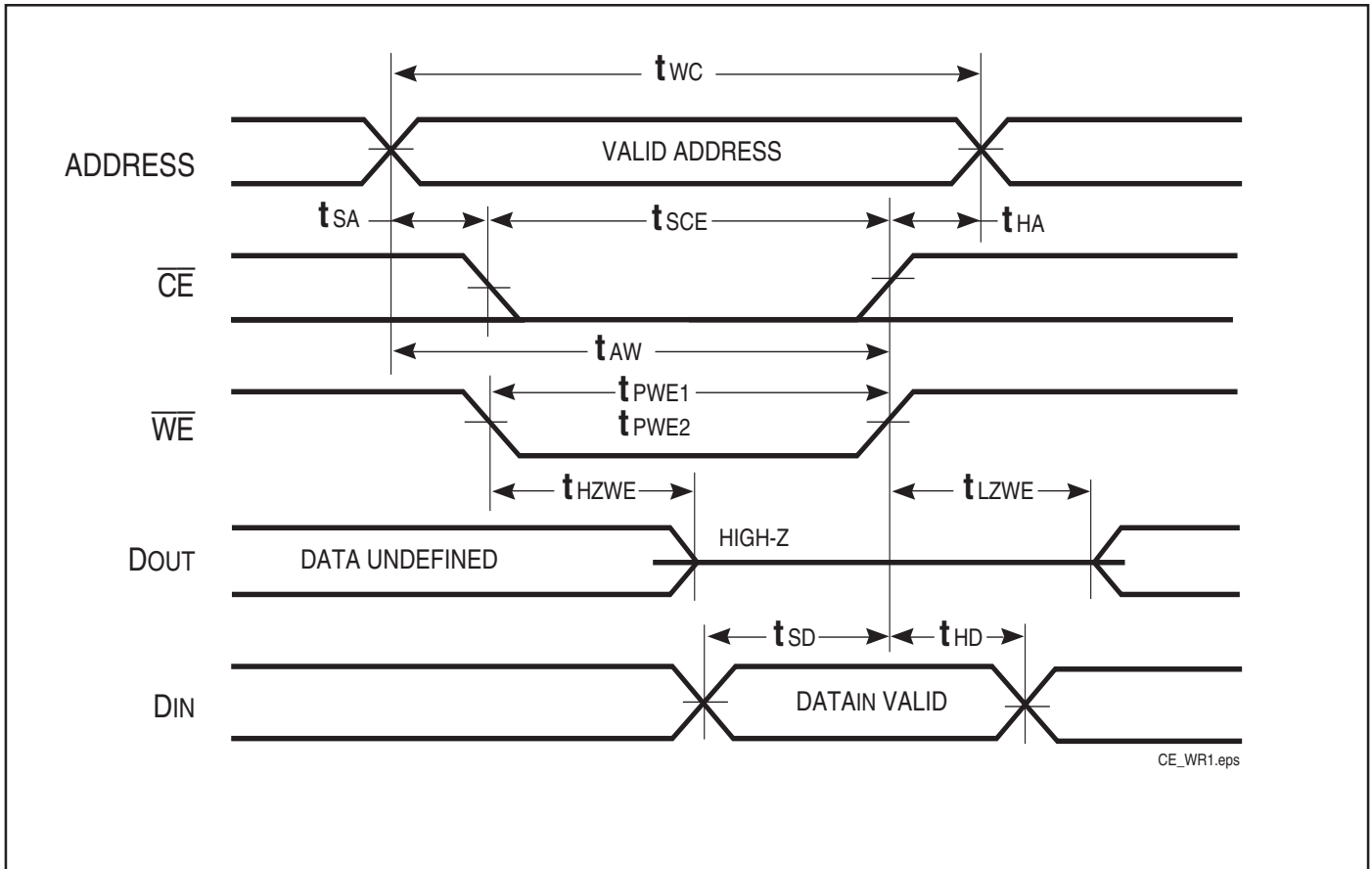

CE\_WR1.eps

AC WAVEFORMS

WRITE CYCLE NO. 2<sup>(1,2)</sup> ( $\overline{WE}$  Controlled:  $\overline{OE}$  is HIGH During Write Cycle)

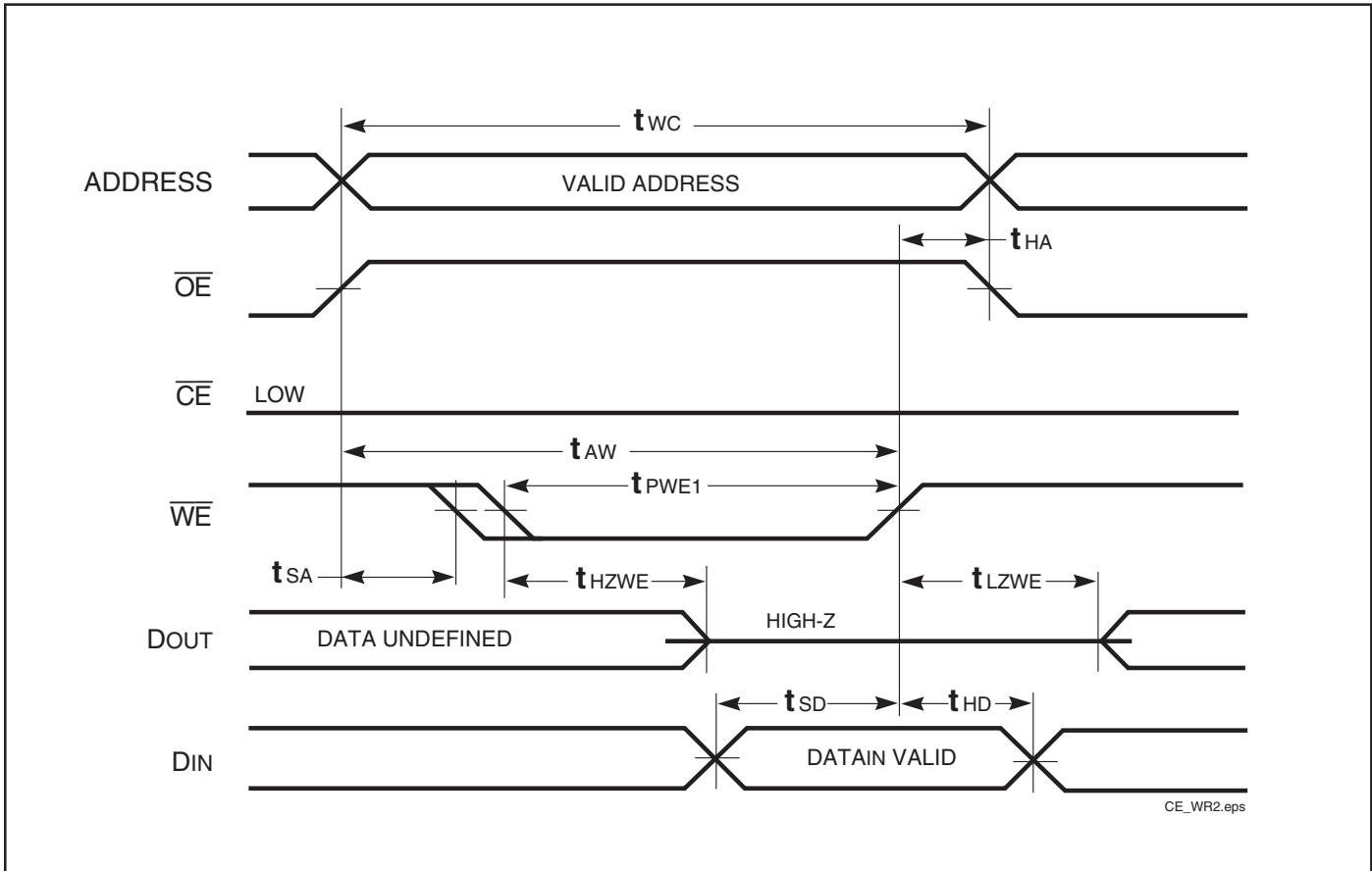

Notes:

1. The internal write time is defined by the overlap of  $\overline{CE}$  LOW and  $\overline{WE}$  LOW. All signals must be in valid states to initiate a Write, but any one can go inactive to terminate the Write. The Data Input Setup and Hold timing are referenced to the rising or falling edge of the signal that terminates the Write.
2. I/O will assume the High-Z state if  $\overline{OE} > V_{IH}$ .

**AC WAVEFORMS**

**WRITE CYCLE NO. 3** ( $\overline{WE}$  Controlled:  $\overline{OE}$  is LOW During Write Cycle)

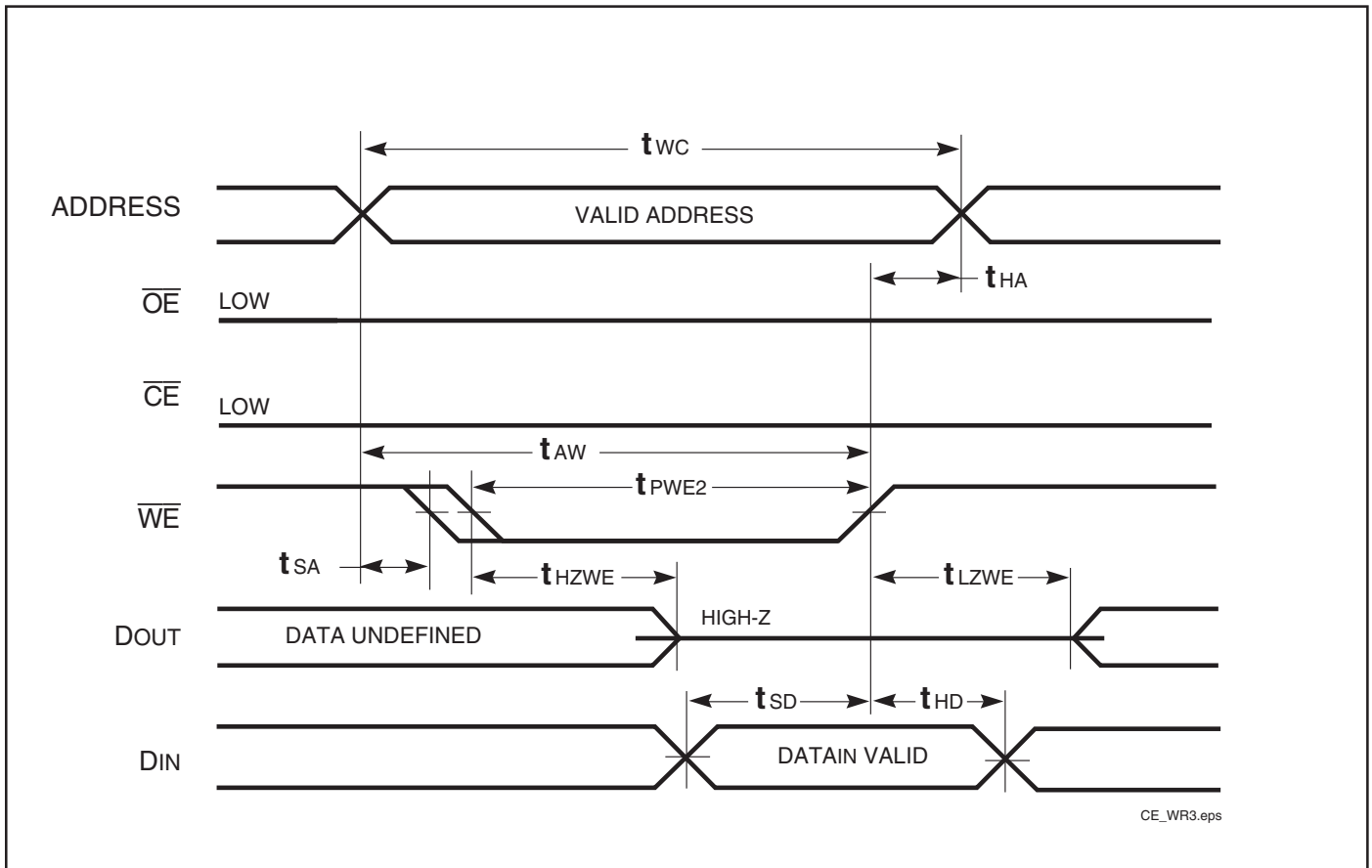

## DATA RETENTION SWITCHING CHARACTERISTICS

Symbol	Parameter	Test Condition	Min.	Max.	Unit
$V_{DR}$	$V_{DD}$ for Data Retention	See Data Retention Waveform	1.2	3.6	V
$I_{DR}$	Data Retention Current	$V_{DD} = 1.2V, \overline{CE} \geq V_{DD} - 0.2V$	—	25 70 4	mA
		Ind. Auto. typ. <sup>(1)</sup>			
$t_{SDR}$	Data Retention Setup Time	See Data Retention Waveform	0	—	ns
$t_{RDR}$	Recovery Time	See Data Retention Waveform	$t_{RC}$	—	ns

**Note:**

1. Typical values are measured at  $V_{DD} = 3.0V$ ,  $T_A = 25^\circ C$  and not 100% tested.

### DATA RETENTION WAVEFORM ( $\overline{CE}$ Controlled)





## ORDERING INFORMATION

**Industrial Range: -40°C to +85°C**

**Voltage Range: 2.4V to 3.6V**

Speed (ns)	Order Part No.	Package
10 (8 <sup>1</sup> )	IS61WV10248BLL-10MI	48 mini BGA (9mm x 11mm)
	IS61WV10248BLL-10MLI	48 mini BGA (9mm x 11mm), Lead-free
	IS61WV10248BLL-10TI	TSOP (Type II)
	IS61WV10248BLL-10TLI	TSOP (Type II), Lead-free

**Note:**

1. Speed = 8ns for  $V_{DD} = 3.3V \pm 5\%$ . Speed = 10ns for  $V_{DD} = 2.4V$  to 3.3V.

**Industrial Range: -40°C to +85°C**

**Voltage Range: 1.65V to 2.2V**

Speed (ns)	Order Part No.	Package
20	IS61WV10248ALL-20MI	48 mini BGA (9mm x 11mm)
	IS61WV10248ALL-20TI	TSOP (Type II)

**Automotive Range: -40°C to +125°C**

**Voltage Range: 2.4V to 3.6V**

Speed (ns)	Order Part No.	Package
10	IS64WV10248BLL-10MA3	48 mini BGA (9mm x 11mm)
	IS64WV10248BLL-10TA3	TSOP (Type II)
	IS64WV10248BLL-10CTLA3	TSOP (Type II), Lead-free, Copper Leadframe

# PACKAGING INFORMATION

Mini Ball Grid Array  
 Package Code: M (48-pin)

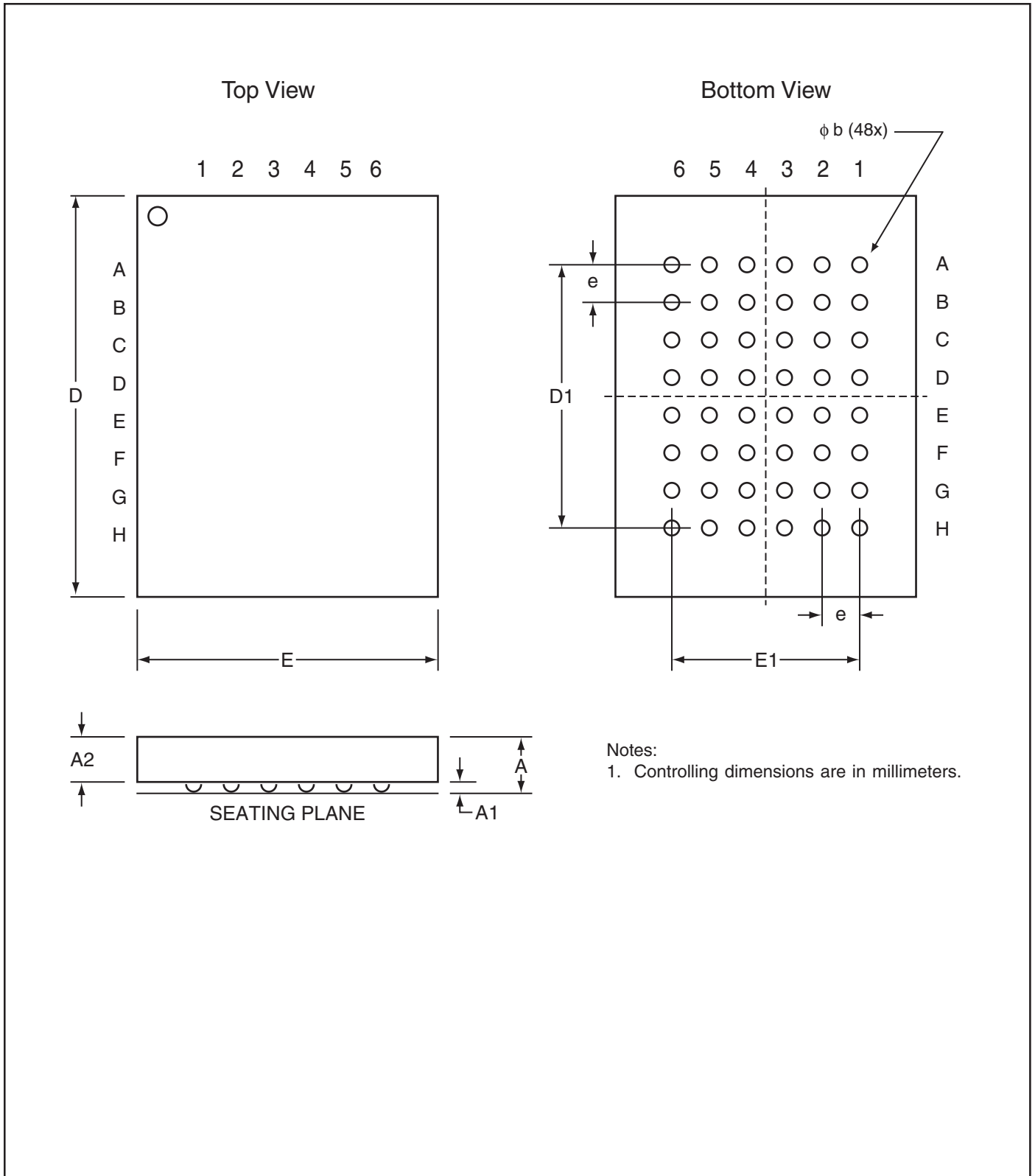

Notes:  
 1. Controlling dimensions are in millimeters.



# PACKAGING INFORMATION

## Mini Ball Grid Array

Package Code: M (48-pin)

### mBGA - 6mm x 8mm

MILLIMETERS				INCHES		
Sym.	Min.	Typ.	Max.	Min.	Typ.	Max.
NO. Leads		<b>48</b>				
A	—	—	1.20	—	—	0.047
A1	0.25	—	0.40	0.010	—	0.016
A2	0.60	—	—	0.024	—	—
D	7.90	8.00	8.10	0.311	0.314	0.319
D1	5.60BSC			0.220BSC		
E	5.90	6.00	6.10	0.232	0.236	0.240
E1	4.00BSC			0.157BSC		
e	0.80BSC			0.031BSC		
b	0.40	0.45	0.50	0.016	0.018	0.020

### mBGA - 7.2mm x 8.7mm

MILLIMETERS				INCHES		
Sym.	Min.	Typ.	Max.	Min.	Typ.	Max.
NO. Leads		<b>48</b>				
A	—	—	1.20	—	—	0.047
A1	0.24	—	0.30	0.009	—	0.012
A2	0.60	—	—	0.024	—	—
D	8.60	8.70	8.80	0.339	0.343	0.346
D1	5.25BSC			0.207BSC		
E	7.10	7.20	7.30	0.280	0.283	0.287
E1	3.75BSC			0.148BSC		
e	0.75BSC			0.030BSC		
b	0.30	0.35	0.40	0.012	0.014	0.016

### mBGA - 9mm x 11mm

MILLIMETERS				INCHES		
Sym.	Min.	Typ.	Max.	Min.	Typ.	Max.
NO. Leads		<b>48</b>				
A	—	—	1.20	—	—	0.047
A1	0.24	—	0.30	0.009	—	0.012
A2	0.60	—	—	0.024	—	—
D	10.90	11.00	11.10	0.429	0.433	0.437
D1	5.25BSC			0.207BSC		
E	8.90	9.00	9.10	0.350	0.354	0.358
E1	3.75BSC			0.148BSC		
e	0.75BSC			0.030BSC		
b	0.30	0.35	0.40	0.012	0.014	0.016

# PACKAGING INFORMATION

Plastic TSOP  
 Package Code: T (Type II)

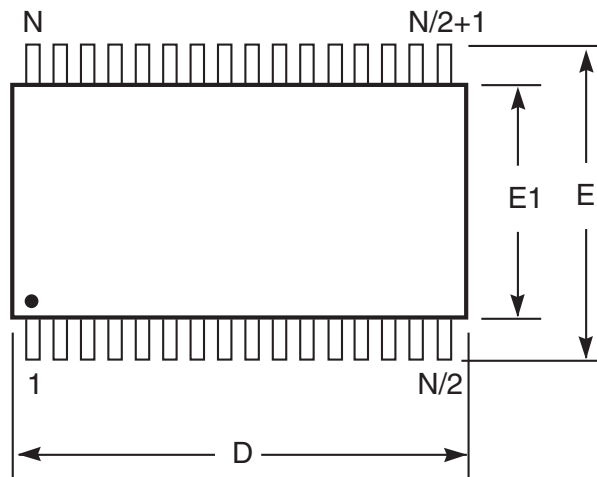

**Notes:**

1. Controlling dimension: millimeters, unless otherwise specified.
2. BSC = Basic lead spacing between centers.
3. Dimensions D and E1 do not include mold flash protrusions and should be measured from the bottom of the package.
4. Formed leads shall be planar with respect to one another within 0.004 inches at the seating plane.



Plastic TSOP (T - Type II)

Symbol	Millimeters		Inches		Millimeters		Inches		Millimeters		Inches	
	Min	Max	Min	Max	Min	Max	Min	Max	Min	Max	Min	Max
Ref. Std.												
No. Leads (N)	32				44				50			
A	—	1.20	—	0.047	—	1.20	—	0.047	—	1.20	—	0.047
A1	0.05	0.15	0.002	0.006	0.05	0.15	0.002	0.006	0.05	0.15	0.002	0.006
b	0.30	0.52	0.012	0.020	0.30	0.45	0.012	0.018	0.30	0.45	0.012	0.018
C	0.12	0.21	0.005	0.008	0.12	0.21	0.005	0.008	0.12	0.21	0.005	0.008
D	20.82	21.08	0.820	0.830	18.31	18.52	0.721	0.729	20.82	21.08	0.820	0.830
E1	10.03	10.29	0.391	0.400	10.03	10.29	0.395	0.405	10.03	10.29	0.395	0.405
E	11.56	11.96	0.451	0.466	11.56	11.96	0.455	0.471	11.56	11.96	0.455	0.471
e	1.27 BSC		0.050 BSC		0.80 BSC		0.032 BSC		0.80 BSC		0.031 BSC	
L	0.40	0.60	0.016	0.024	0.41	0.60	0.016	0.024	0.40	0.60	0.016	0.024
ZD	0.95 REF		0.037 REF		0.81 REF		0.032 REF		0.88 REF		0.035 REF	
α	0°	5°	0°	5°	0°	5°	0°	5°	0°	5°	0°	5°

Copyright © 2003 Integrated Silicon Solution, Inc. All rights reserved. ISSI reserves the right to make changes to this specification and its products at any time without notice. ISSI assumes no liability arising out of the application or use of any information, products or services described herein. Customers are advised to obtain the latest version of this device specification before relying on any published information and before placing orders for products.

Integrated Silicon Solution, Inc. — [www.issi.com](http://www.issi.com) — 1-800-379-4774

Rev. F  
 06/18/03



## Стандарт Электрон Связь

Мы молодая и активно развивающаяся компания в области поставок электронных компонентов. Мы поставляем электронные компоненты отечественного и импортного производства напрямую от производителей и с крупнейших складов мира.

Благодаря сотрудничеству с мировыми поставщиками мы осуществляем комплексные и плановые поставки широчайшего спектра электронных компонентов.

Собственная эффективная логистика и склад в обеспечивает надежную поставку продукции в точно указанные сроки по всей России.

Мы осуществляем техническую поддержку нашим клиентам и предпродажную проверку качества продукции. На все поставляемые продукты мы предоставляем гарантию .

Осуществляем поставки продукции под контролем ВП МО РФ на предприятия военно-промышленного комплекса России , а также работаем в рамках 275 ФЗ с открытием отдельных счетов в уполномоченном банке. Система менеджмента качества компании соответствует требованиям ГОСТ ISO 9001.

Минимальные сроки поставки, гибкие цены, неограниченный ассортимент и индивидуальный подход к клиентам являются основой для выстраивания долгосрочного и эффективного сотрудничества с предприятиями радиоэлектронной промышленности, предприятиями ВПК и научно-исследовательскими институтами России.

С нами вы становитесь еще успешнее!

### Наши контакты:

**Телефон:** +7 812 627 14 35

**Электронная почта:** [sales@st-electron.ru](mailto:sales@st-electron.ru)

**Адрес:** 198099, Санкт-Петербург,  
Промышленная ул, дом № 19, литера Н,  
помещение 100-Н Офис 331