

MINI MCR-2-UI-FRO(-PT)(-C)

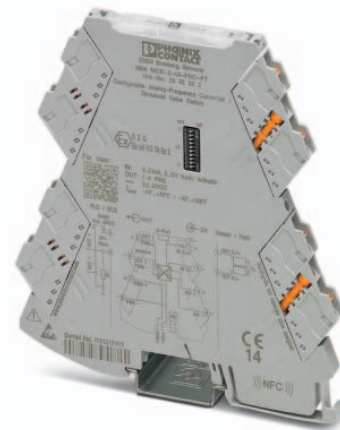

Analog frequency transducer with limit value functionality

Data sheet
106296_en_01

© PHOENIX CONTACT 2016-02-26

1 Description

This freely adjustable analog frequency transducer with additional switching output, limit function, and plug-in connection technology serves to convert standard analog signals into frequency signals or into pulse width modulated (PWM) signals.

On the input side, current signals between 0 mA and 24 mA and voltage signals between 0 V and 12 V can be processed.

On the output side, frequency signals between 0 Hz and 11 kHz, and PWM signals from 0 % to 100 % are possible.

Furthermore, the output can also be operated as an additional switching output so that two independent switching outputs are available.

The external circuit of the frequency output shows the block diagram. The additional switching output (terminals 3 and 4) will be switched identically.

The minimum measurement span is 1 mA or 0.5 V. Full precision is achieved with a span of more than 10 mA or 5 V.

You can optionally configure the device using DIP switches, or with enhanced functionality via the S-PORT using the standard Analog-Conf software via FDT/DTM, or without further accessories using the Mini Analog Pro Smartphone app.

Features

- Configurable analog frequency transducer with switching output and plug-in connection technology
- Frequency output can be used as second switching output as an option
- Freely adjustable input and output
- Screw or push-in connection available
- Can be supplied configured or unconfigured
- Reinforced insulation according to IEC 61010-1
- Supply voltage range 9.6 ... 30 V DC



WARNING: Correct usage in potentially explosive areas

The module is a category 3 item of electrical equipment. It is absolutely vital to follow the instructions provided here during installation and observe the information in the "Safety regulations and installation notes".



This device offers the option of NFC communication.

You can use the MINI Analog Pro Smartphone app via the NFC interface of your Smartphone to configure the device and to call-up DIP switch setting help and comprehensive module information.

The MINI Analog Pro Smartphone app is available to you free.



Make sure you always use the latest documentation.

It can be downloaded from the product at phoenixcontact.net/products.

This document is valid for the products listed in the "Ordering data".

2	Table of contents	
1	Description	1
2	Table of contents	2
3	Ordering data	3
4	Technical data	5
5	Safety regulations and installation notes.....	7
	5.1 Installation notes	7
	5.2 Installation in Zone 2.....	7
	5.3 UL Notes	7
6	Installation	8
	6.1 Connection notes	8
	6.2 Structure	8
	6.3 Block diagram.....	8
	6.4 Power supply.....	8
	6.5 Assembly.....	9
	6.6 FASTCON Pro plugs	9
	6.7 Fault monitoring FM	10
	6.8 Current measurement	10
	6.9 Marking.....	10
7	Configuration	11
	7.1 Configuration via DIP switches	11
	7.2 Configuration via software.....	13
	7.3 Configuration via MINI Analog Pro app.....	13
8	Function description	14
	8.1 Output signals.....	14
	8.2 Digital switching output	14
	8.3 Analog switching output	15
	8.4 Monitoring.....	15
	8.5 Limiting behavior of the analog output.....	16
	8.6 Output response in the event of fast input signal change.....	16
	8.7 Diagnostic functions and error messages	16
	8.8 Simulation mode/force	16
	8.9 Measuring rate.....	17
9	Diagnostics and status indicators	17

3 Ordering data

Description	Type	Order No.	Pcs./Pkt.
Analog frequency transducer with limit value functionality and plug-in connection technology for converting standard signals into frequency or PWM signals. Configurable via DIP switch or software. Screw connection technology, standard configuration.	MINI MCR-2-UI-FRO	2902031	1
Analog frequency transducer with limit value functionality and plug-in connection technology for converting standard signals into frequency or PWM signals. Configurable via DIP switch or software. Push-in connection technology, standard configuration.	MINI MCR-2-UI-FRO-PT	2902032	1
Analog frequency transducer with limit value functionality and plug-in connection technology for converting standard signals into frequency or PWM signals. Configurable via DIP switch or software. Screw connection technology, order configuration.	MINI MCR-2-UI-FRO-C	2906201	1
Analog frequency transducer with limit value functionality and plug-in connection technology for converting standard signals into frequency or PWM signals. Configurable via DIP switch or software. Push-in connection technology, order configuration.	MINI MCR-2-UI-FRO-PT-C	2906202	1
Accessories	Type	Order No.	Pcs./Pkt.
Near Field Communication (NFC) programming adapter with USB interface, for the wireless programming of MINI Analog Pro signal conditioners with software. No separate USB driver is required.	NFC-USB-PROG-ADAPTER	2900013	1
Programming adapter with USB interface, for programming with software. The USB driver is included in the software solutions for the products to be programmed, such as measuring transducers or motor managers.	IFS-USB-PROG-ADAPTER	2811271	1
DIN rail connector for DIN rail mounting. Universal for TBUS housing. Gold-plated contacts, 5-pos. Plug component, Number of positions: 5, Pitch: 3.81 mm	ME 6,2 TBUS-2 1,5/5-ST-3,81 GN	2869728	10
DIN rail connector (TBUS), 5-pos., for bridging the supply voltage, can be snapped onto NS 35/... DIN rails according to EN 60715	ME 6,2 TBUS-2 1,5/5-ST-3,81 GY	2695439	10
Power terminal with plug-in connection technology for delivering the supply voltage to the DIN rail connector. Monitoring of the supply voltages in combination with the fault monitoring module. Screw connection technology	MINI MCR-2-PTB	2902066	1
Power terminal with plug-in connection technology for delivering the supply voltage to the DIN rail connector. Monitoring of the supply voltages in combination with the fault monitoring module. Push-in connection technology	MINI MCR-2-PTB-PT	2902067	1
Fault monitoring module with plug-in connection technology for evaluating and reporting group errors from the FM system and for monitoring the supply voltages. Error reporting via N/O contact. Screw connection technology, standard configuration	MINI MCR-2-FM-RC	2904504	1
Fault monitoring module with plug-in connection technology for evaluating and reporting group errors from the FM system and for monitoring the supply voltages. Error reporting via N/O contact. Push-in connection technology, standard configuration	MINI MCR-2-FM-RC-PT	2904508	1
Primary-switched MINI POWER supply for DIN rail mounting, input: 1-phase, output: 24 V DC/1.5 A	MINI-SYS-PS-100-240AC/24DC/1.5	2866983	1
Marker for end clamp, Sheet, white, unlabeled, can be labeled with: THERMOMARK CARD, BLUEMARK CLED, BLUEMARK LED, TOPMARK LASER, Mounting type: snapped into marker carrier, Lettering field: 30 x 5 mm	UCT-EM (30X5)	0801505	10
Marker for end clamp, can be ordered: by sheet, white, labeled according to customer specifications, Mounting type: snapped into marker carrier, Lettering field: 30 x 5 mm	UCT-EM (30X5) CUS	0801589	1
Marker for end clamp, Sheet, yellow, unlabeled, can be labeled with: THERMOMARK CARD, BLUEMARK CLED, BLUEMARK LED, TOPMARK LASER, Mounting type: snapped into marker carrier, Lettering field: 30 x 5 mm	UCT-EM (30X5) YE	0830340	10

Accessories	Type	Order No.	Pcs./Pkt.
Marker for end clamp, can be ordered: by sheet, yellow, labeled according to customer specifications, Mounting type: snapped into marker carrier, Lettering field: 30 x 5 mm	UCT-EM (30X5) YE CUS	0830348	1
Plastic label, Sheet, white, unlabeled, can be labeled with: BLUEMARK CLED, BLUEMARK LED, Plotter, Mounting type: Adhesive, Lettering field: 15 x 5 mm	UC-EMLP (15X5)	0819301	10
Plastic label, Sheet, white, unlabeled, can be labeled with: BLUEMARK CLED, BLUEMARK LED, Plotter, Mounting type: Adhesive, Lettering field: 15 x 5 mm	UC-EMLP (15X5)L	0820138	5
Plastic label, Sheet, yellow, unlabeled, can be labeled with: BLUEMARK CLED, BLUEMARK LED, Plotter, Mounting type: Adhesive, Lettering field: 15 x 5 mm	UC-EMLP (15X5) YE	0822615	10
Plastic label, can be ordered: by sheet, white, labeled according to customer specifications, Mounting type: Adhesive, Lettering field: 15 x 5 mm	UC-EMLP (15X5) CUS	0824550	1
Plastic label, can be ordered: by sheet, yellow, labeled according to customer specifications, Mounting type: Adhesive, Lettering field: 15 x 5 mm	UC-EMLP (15X5) YE CUS	0824551	1
Plastic label, can be ordered: by sheet, white, labeled according to customer specifications, Mounting type: Adhesive, Lettering field: 15 x 5 mm	UC-EMLP (15X5)L CUS	0824552	1
Plastic label, Sheet, yellow, unlabeled, can be labeled with: BLUEMARK CLED, BLUEMARK LED, Plotter, Mounting type: Adhesive, Lettering field: 15 x 5 mm	UC-EMLP (15X5)L YE	0825325	5
Plastic label, can be ordered: by sheet, yellow, labeled according to customer specifications, Mounting type: Adhesive, Lettering field: 15 x 5 mm	UC-EMLP (15X5)L YE CUS	0826680	1
Plastic label, Sheet, silver, unlabeled, can be labeled with: BLUEMARK CLED, BLUEMARK LED, Plotter, Mounting type: Adhesive, Lettering field: 15 x 5 mm	UC-EMLP (15X5) SR	0828095	10
Plastic label, can be ordered: by sheet, silver, labeled according to customer specifications, Mounting type: Adhesive, Lettering field: 15 x 5 mm	UC-EMLP (15X5) SR CUS	0828099	1
Plastic label, Sheet, silver, unlabeled, can be labeled with: BLUEMARK CLED, BLUEMARK LED, Plotter, Mounting type: Adhesive, Lettering field: 15 x 5 mm	UC-EMLP (15X5)L SR	0828103	5
Marker strip, Roll, white, unlabeled, can be labeled with: THERMOMARK ROLL, THERMOMARK X, THERMOMARK S1.1, THERMOMARK ROLL X1, Mounting type: Adhesive, Lettering field: continuous x 5 mm	SK 5,0 WH:REEL	0805221	1
Bluetooth programming adapter with μ USB and S-PORT interface for wireless programming and monitoring. The driver is included in the software solutions for the products to be programmed, such as measuring transducers or motor managers.	IFS-BT-PROG-ADAPTER	2905872	1

4 Technical data

Input	
Configurable/programmable	Yes
Voltage input signal	0 V ... 10 V (via DIP switch) 2 V ... 10 V (via DIP switch) 0 V ... 5 V (via DIP switch) 1 V ... 5 V (via DIP switch) 10 V ... 0 V (via DIP switch) 10 V ... 2 V (via DIP switch) 5 V ... 0 V (via DIP switch) 5 V ... 1 V (via DIP switch) 0 V ... 12 V (Can be set via software)
Max. voltage input signal	12 V
Current input signal	0 mA ... 0.02 A (via DIP switch) 4 mA ... 0.02 A (via DIP switch) 0 mA ... 0.01 A (via DIP switch) 2 mA ... 0.01 A (via DIP switch) 20 mA ... 0 A (via DIP switch) 20 mA ... 0.004 A (via DIP switch) 10 mA ... 0 A (via DIP switch) 10 mA ... 0.002 A (via DIP switch) 0 mA ... 0.024 A (Can be set via software)
Max. current input signal	24 mA
Input resistance of voltage input	> 120 kΩ
Input resistance current input	approx. 50 Ω
Output	
Output description	Switching output
Number of outputs	1
Contact type	1 N/O contact
Minimum switching voltage	1 V
Maximum switching voltage	30 V DC
Min. switching current	100 μA
Max. switching current	100 mA (at 30 V)
Frequency output	0 Hz ... 10 kHz (via DIP switches) 0 Hz ... 5 kHz (via DIP switches) 0 Hz ... 2.5 kHz (via DIP switches) 0 Hz ... 1 kHz (via DIP switches) 0 Hz ... 500 Hz (via DIP switches) 0 Hz ... 250 Hz (via DIP switches) 0 Hz ... 100 Hz (via DIP switches) 0 Hz ... 50 Hz (via DIP switches) 0 Hz ... 10.5 kHz (via software)
Load min.	$4 \text{ mA} \leq (U_L / R_L) \leq 100 \text{ mA}$
Output signal PWM	15.6 kHz (10 bit) 1.9 kHz (10 bit) 3.9 kHz (12 bit) 488 Hz (12 bit) 977 Hz (14 bit) 122 Hz (14 bit) 244 Hz (16 bit) 31 Hz (16 bit)
Load min.	$12 \text{ mA} \leq (U_L / R_L) \leq 100 \text{ mA}$
Load current maximum	100 mA
Maximum switching voltage	30 V
Overrange/underrange	Can be set (via software)

Supply

Nominal supply voltage	24 V DC
Supply voltage range	9.6 V DC ... 30 V DC (The DIN rail bus connector (ME 6,2 TBUS-2 1,5/5-ST-3,81 GN, Order No. 2869728) can be used to bridge the supply voltage. It can be snapped onto a 35 mm DIN rail according to EN 60715))
Typical current consumption	27 mA (12 V DC) 13.5 mA (24 V DC)
Power consumption	≤ 350 mW (9.6 V DC)

General data

Temperature coefficient, typical	0.01 %/K
Maximum temperature coefficient	< 0.01 %/K
Step response (0–99%)	120 ms (15 Hz sample rate)
Frequency output	35 ms (60 Hz sample rate)
Frequency output	15 ms (240 Hz sample rate)
Frequency output	130 ms (15 Hz sample rate)
Switching output	40 ms (60 Hz sample rate)
Switching output	20 ms (240 Hz sample rate)
Electrical isolation	Reinforced insulation in accordance with IEC 61010-1
Overvoltage category	II
Mounting position	any
Degree of protection	IP20
Degree of pollution	2
Rated insulation voltage	300 V (effective)
Test voltage, input/output/supply	3 kV (50 Hz, 1 min.)
Dimensions W/H/D	6.2 mm / 110.5 mm / 120.5 mm
Type of housing	PBT gray

Connection data
Screw connection
Push-in connection

Solid conductor cross section with ferrule	0.2 mm ² ... 1.5 mm ²	0.14 mm ² ... 2.5 mm ²
Solid conductor cross section without ferrule	0.2 mm ² ... 2.5 mm ²	0.14 mm ² ... 2.5 mm ²
Conductor cross section, flexible	0.2 mm ² ... 1.5 mm ²	0.14 mm ² ... 2.5 mm ²
Conductor cross section AWG	24 ... 12	24 ... 12
Stripping length	10 mm	10 mm

Ambient conditions

Ambient temperature (operation)	-40 °C ... 70 °C
Ambient temperature (storage/transport)	-40 °C ... 85 °C
Permissible humidity (operation)	5 % ... 95 % (non-condensing)

Conformance with EMC Directive 2004/108/EC (valid until 19.04.2016) / 2014/30/EU (valid from 20.04.2016)

Noise immunity according to EN 61000-6-2
When being exposed to interference, there may be minimal deviations.

Noise emission according to EN 61000-6-4

Conformance / approvals

Conformance	CE-compliant
ATEX	⊕ II 3 G Ex nA IIC T4 Gc X
UL, USA / Canada	UL 508 Listed
UL, USA / Canada	Class I, Div. 2, Groups A, B, C, D T6
UL, USA / Canada	Class I, Zone 2, Group IIC T6
Shipbuilding	GL applied for

5 Safety regulations and installation notes

5.1 Installation notes

- The category 3 device is suitable for installation in potentially explosive area zone 2. It fulfills the requirements of EN 60079-0:2012 and EN 60079-15:2010.
- Installation, operation, and maintenance may only be carried out by qualified electricians. Follow the installation instructions as described. When installing and operating the device, the applicable regulations and safety directives (including national safety directives), as well as generally approved technical regulations, must be observed. The safety data is provided in this package slip and on the certificates (conformity assessment, additional approvals where applicable).
- While the devices are in operation, contact-dangerous voltages may be present on the control elements. For this reason parameterization, conductor connection, and opening of the module lid are allowed only when devices are in a de-energized state unless the connected circuits are exclusively SELV or PELV circuits.
- The device must not be opened or modified. Do not repair the device yourself, replace it with an equivalent device. Repairs may only be carried out by the manufacturer. The manufacturer is not liable for damage resulting from violation.
- The IP20 protection (IEC 60529/EN 60529) of the device is intended for use in a clean and dry environment. The device must not be subject to mechanical strain and/or thermal loads, which exceed the limits described.
- The device is not designed for use in atmospheres with a danger of dust explosions.
- The device complies with the EMC regulations for industrial areas (EMC class A). When using the device in residential areas, it may cause radio interference.
- If the device is not used as described in the documentation, the intended protection can be negatively affected.
- To protect the device against mechanical or electrical damage, install it in a suitable housing with appropriate degree of protection as per IEC 60529.
- Provide a switch/circuit breaker close to the device, which is labeled as the disconnecting device for this device.
- Provide for an overcurrent protection device ($I \leq 4 \text{ A}$) in the installation.

- There is a double isolation of $300 \text{ V}_{\text{eff}}$ between neighboring modules of the same type oriented the same way. The device has a base isolation of $150 \text{ V}_{\text{eff}}$ to other neighboring modules on the side with the DIP switch.
- The voltages present at the input, output and supply are extra-low voltages (ELV). Depending on the application, dangerous voltage ($> 30 \text{ V}$) against ground could occur. For this event, safe electrical isolation from the other connections has been implemented.
- The device must be stopped if it is damaged, has been subjected to an impermissible load, stored incorrectly, or if it malfunctions.
- Only use copper connecting cables providing the permitted temperature range ($60^\circ\text{C}/75^\circ\text{C}$).

5.2 Installation in Zone 2

- Observe the specified conditions for use in potentially explosive areas! Install the device in a suitable approved housing (with a minimum of IP54 protection) that meets the requirements of EN 60079-15. Observe the requirements of EN 60079-14.
- Only devices which are designed for operation in Ex zone 2 and are suitable for the conditions at the installation location may be connected to the circuits in the Ex zone.
- In potentially explosive areas, terminals may only be snapped onto or off the DIN rail connector and wires may only be connected or disconnected when the power is switched off.
- The device must be stopped and immediately removed from the Ex area if it is damaged, was subject to an impermissible load, stored incorrectly or if it malfunctions.

5.3 UL Notes

INDUSTRIAL CONTROL EQUIPMENT FOR HAZARDOUS LOCATIONS 45FP

- 1 Suitable for use in class 1, division 2, groups A, B, C and D hazardous locations, or nonhazardous locations only.
- 2 WARNING - EXPLOSION HAZARD: Do not disconnect equipment unless power has been removed or the area is known to be non-hazardous.
- 3 WARNING - EXPLOSION HAZARD: Substitution of any components may impair suitability for Class I, Division 2.
- 4 This device is open-type and is required to be installed in an enclosure suitable for the environment and can only be accessed with the use of a tool or key.

6 Installation

6.1 Connection notes



The device contains components that can be damaged or destroyed by electrostatic discharge. When handling the device, observe the necessary safety precautions against electrostatic discharge (ESD) according to EN 61340-5-1 and IEC 61340-5-1.

6.2 Structure

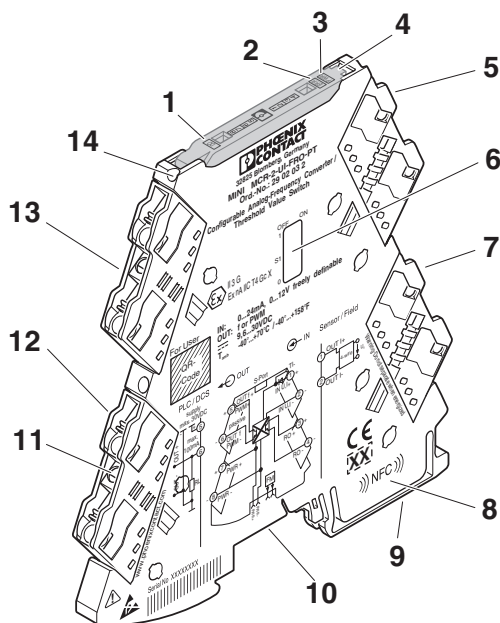

Figure 1 Structure

- 1 DO switch contact yellow LED
- 2 Error indicator "ERR" red LED
- 3 Green "PWR" LED, power supply
- 4 Cover with labeling option
- 5 Voltage/current input
- 6 DIP switch S1
- 7 Output: Switch contact 2
- 8 NFC coil
- 9 Universal snap-on foot for EN DIN rails
- 10 Connection for DIN rail connector
- 11 Spindle screw
- 12 Supply voltage
- 13 Frequency/PWM output, switch contact 1
- 14 Current measuring socket

6.3 Block diagram

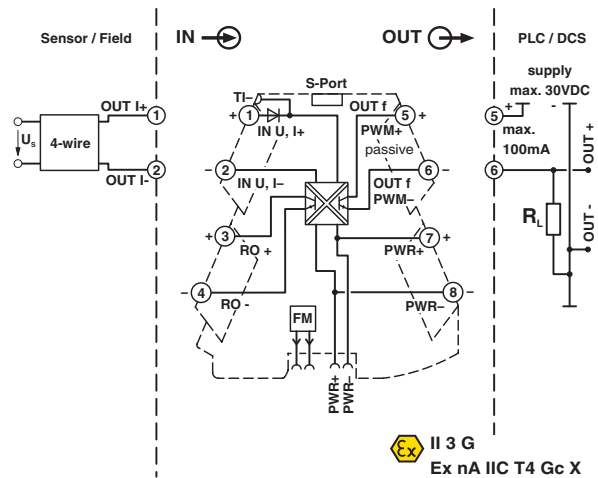

Figure 2 Block diagram

6.4 Power supply

You must refer to the MACX and MINI Analog power manual for the design of the power supply.



NOTE

Never connect the supply voltage directly to the DIN rail connector. Drawing power from individual devices is not permitted!

Supply via the module

Where the total current consumption of the aligned modules does not exceed 400 mA, the power can be supplied directly at the connection terminal blocks of the module.

We recommend connecting a 630 mA fuse (normal-blow or slow-blow) upstream.

Supply via a power terminal block

The MINI MCR-2-PTB power terminal block (Order No. 2902066) or the MINI MCR-2-PTB-PT power terminal block (Order No. 2902067) of the same shape is used to supply the supply voltage to the DIN rail connector.

We recommend connecting a 4 A fuse upstream.

Supply via a system power supply unit

The system power supply unit with 1.5 A output current connects the DIN rail connector to the supply voltage and can thus be used to supply several modules from the mains.

- MINI-SYS-PS-100-240AC/24DC/1.5 (Order No. 2866983)
- Potentially explosive areas:
MINI-PS-100-240AC/24DC/1.5/EX (Order No. 2866653)

6.5 Assembly

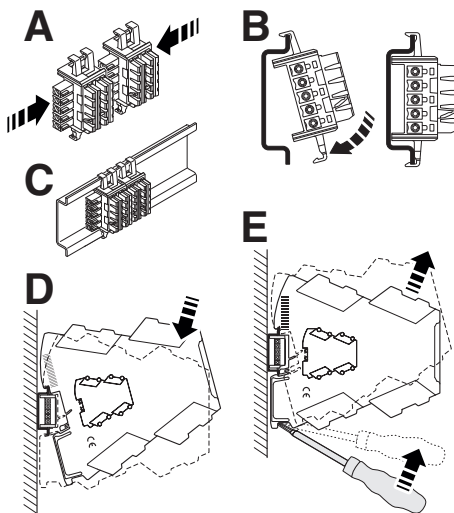

Figure 3 Mounting and removing

- Mount the module on a 35 mm DIN rail according to EN 60715.
- When using the DIN rail connector, first place it into the DIN rail (see A – C). It is used to bridge the power supply. It is also absolutely vital that you snap the module and the DIN rail connector into position in the correct direction: the snap-on foot should be at the bottom and the connector on the left.

6.6 FASTCON Pro plugs

The device has pluggable connection terminals with an integrated test disconnect terminal block, with either push-in or screw-in connection technology.

You can plug or screw the FASTCON Pro plugs onto the device directly without tools. You can use the integrated spindle screw to easily remove the plugs from the module or set the isolating position, even when the plugs are connected. For this purpose, use a screwdriver of sufficient width, e.g. SZF 1-0.6x3.5 (order number: 1204517).

The spindle screw will turn by itself when the FASTCON Pro plugs are connected. There is no need for you to fix the spindle screw in place as well.

4-way coding prevents incorrect insertion into the module.

Screw connection:

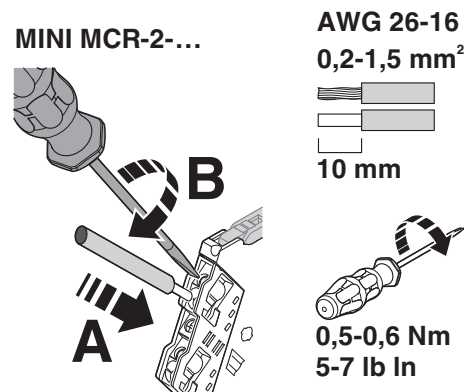

Figure 4 Screw connection

- Insert the wire into the corresponding connection terminal block.
- Use a screwdriver to tighten the screw in the opening above the connection terminal block.

Push-in connection:

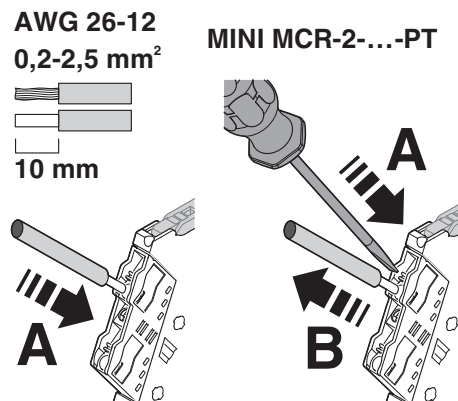

Figure 5 Push-in connection

- Insert the wire into the corresponding connection terminal block.

6.7 Fault monitoring FM

In addition to module and power supply failures, known faults in the signal input of the module are reported via the DIN rail connector to the form-matched MINI MCR-2-FM-RC (order number 2904504) or MINI MCR-2-FM-RC-PT (order number 2904508) fault monitoring module. The module reports the error centrally via an N/C contact.

A fault monitoring module is only required once in a group. There is no need for individual evaluation of up to 115 connected Mini Analog Pro signal conditioners.

For the behavior of the fault monitoring contact with the various DIP switch configurations, see the relevant table in the data sheet at phoenixcontact.net/products.

6.8 Current measurement

The device allows current measurement without disconnection of the conductors by means of integrated test disconnect terminals.

Test sockets which support current measurement are marked TI+ or TI-.

For the current measurement, use 2 mm probe tips of the type Fluke TL75-1 or probe tips with a comparable tip shape.

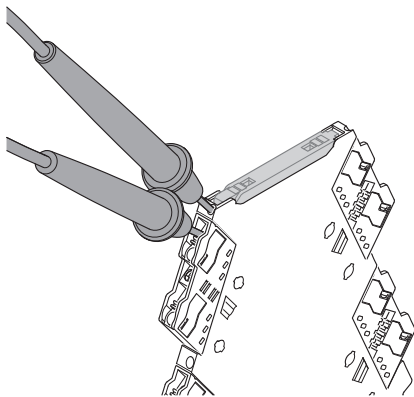

Figure 6 Test disconnect terminal block

Furthermore, individual circuits can be specifically disconnected, e.g. for commissioning.

You can set the isolating position by turning the integrated spindle screw through 180°. The isolating position is indicated by the marking on the plugs.

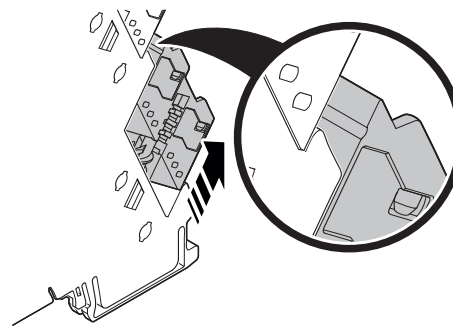

Figure 7 Disconnect position

6.9 Marking

Standard UCT-EM... or UC-EMLP tags are available for marking the devices and can be printed as per customer requirements. In addition, the covers provide enough space for the use of freely chosen sticky labels such as SK 5.0 WH:REEL without concealing the LED diagnostic indicators.

7 Configuration

Standard configuration for devices not configured to order:

Sample rate: 15 Hz; input 4...20 mA; output 0...10 kHz; no output limitation; fault monitoring contact reacts for all faults; configurable via software; error evaluation:

	Open circuit/short circuit	Measuring range overrange	Measuring range underrange
f	105 %	100 %	0 %
PWM	0 %	95 %	5 %

The values relate to the entire output range.

7.1 Configuration via DIP switches

At delivery, all DIP switches are in the "OFF" position.

Configure the DIP switches according to the planned application using the configuration tables.

Configuration tables

		• ≙ ON DIP S1									
		1	2	3	4	5	6	7	8	9	0
Default											
DIP switch configuration off											
DIP switch configuration on											•
Input signal	15 Hz										•
	60 Hz	•									•
	0...20 mA										•
	4...20 mA		•								•
	0...10 mA			•							•
	2...10 mA		•	•							•
	0...10 V				•						•
	2...10 V		•	•							•
	0...5 V				•	•					•
	1...5 V		•	•	•						•
	20...0 mA					•					•
	20...4 mA		•			•					•
	10...0 mA			•		•					•
	10...2 mA		•	•		•					•
	10...0 V				•	•					•
	10...2 V		•	•	•						•
	5...0 V			•	•	•					•
	5...1 V		•	•	•	•					•
Output signal frequency	0...10 kHz										•
	0...5 kHz						•				•
	0...2.5 kHz							•			•
	0...1 kHz							•	•		•
	0...500 Hz								•		•
	0...250 Hz							•	•		•
	0...100 Hz								•	•	•
	0...50 Hz								•	•	•
Output signal PWM	15.6 kHz (10 bits)										•
	1.9 kHz (10 bits)						•				•
	3.9 kHz (12 bits)							•			•
	488 Hz (12 bits)							•	•		•
	977 Hz (14 bits)								•	•	•
	122 Hz (14 bits)							•		•	•
	244 Hz (16 bits)								•	•	•
31 Hz (16 bits)								•	•	•	

7.2 Configuration via software



Use the IFS-USB-PROG-ADAPTER programming adapter (Order No.: 2811271), the NFC-USB-PROG-ADAPTER (Order No.: 2900013), or the IFS-BT-PROG-ADAPTER (Order No.: 2905872) for connection of the device and PC.

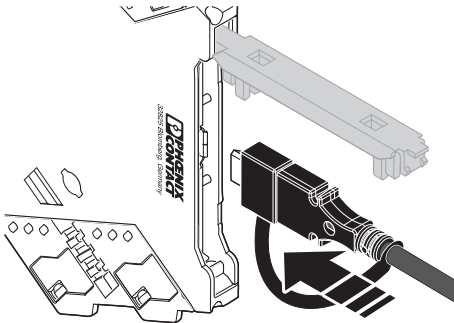

Figure 8 Programming connection

In addition to DIP switch settings, software configuration offers enhanced setting options and a monitoring function for maintenance purposes.

The following free software solutions are available for you to download from the Internet.

- ANALOG-CONF standard software
- FDT/DTM solutions: FDT frame application and DTM packages

7.3 Configuration via MINI Analog Pro app

In addition to DIP switch settings, app configuration offers enhanced setting options.

Using the MINI Analog Pro Smartphone app via the NFC interface of your Smartphone you can configure the module without an additional programming adapter or cables.

Alternatively, you can use the Bluetooth programming adapter (Order No. 2905872).

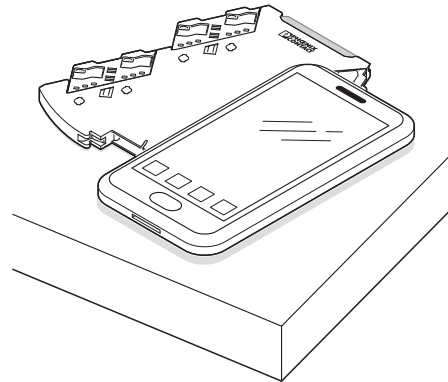

Figure 9 Configuration

8 Function description

8.1 Output signals

The input signals can be converted into frequency signals or pulse width modulated (PWM) signals (0 ... 100%).

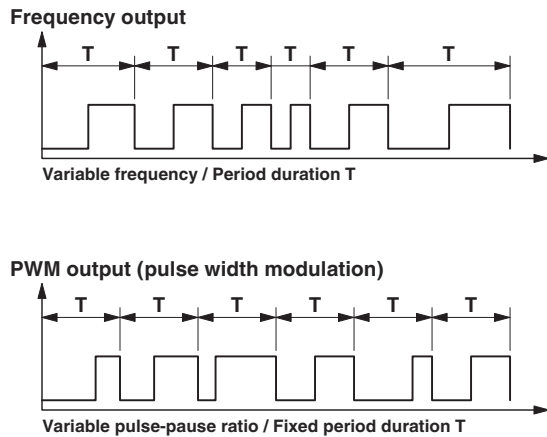

Figure 10 Output signals

8.2 Digital switching output

The digital switching output is a transistor output that can be used as a threshold value output.

You can define up to 2 switching points for a characteristic curve.



As an option, you can also operate the F/PWM output as an additional switching output so that two independent switching outputs are available.

Switching points

The switching points are set finitely and in the selected unit (V, mA) and relate to the measuring input. In the case of a user characteristic curve, use the unit selected there.

A fixed mini hysteresis exists for each switching point, which is independent of the respective input signal. The mini hysteresis for the switching point is $\pm 0.1\%$ of the nominal input range.

In the case of the “Two switching points with hysteresis” switching behavior (menu item in ANALOG-CONF), there is no mini hysteresis for the switching points.

For user characteristic curves, the difference between the first and the last Y value is the nominal range.

The up to two switching points can be configured within the input signal range as follows.

Nominal measuring range	Input signal range
0 V ... 10 V	0.020 V ... 11.980 V
0 V ... 5 V	0.010 V ... 5.990 V
0 V ... 2.5 V	0.005 V ... 2.995 V
0 mA ... 20 mA	0.040 mA ... 23.960 mA
0 mA ... 10 mA	0.020 mA ... 11.980 mA
0 mA ... 5 mA	0.010 mA ... 5.990 mA

Switching points (including the mini hysteresis) must not exceed the maximum measuring range.

The minimum distance between two switching points is 0.2% of the nominal input range. This also applies to user characteristic curves.

Switching behavior

You can configure eight different switching behaviors.

Switching behavior	Number of switching points	Normal function of the switching output
0	0	Permanently inactive (not connected through)
1	0	Permanently active (connected through)
2	1	Active after the switching point is exceeded
3	1	Inactive after the switching point is exceeded
4	Two switching points with hysteresis	Active after the upper switching point is exceeded, inactive after the lower switching point is undershot. If the input variable assigned to the switching output lies between the two switching points when the module is switched on, the switching output is inactive.
5	Two switching points with hysteresis	Inactive after the upper switching point is exceeded, active after the lower switching point is undershot. If the input variable assigned to the switching output lies between the two switching points when the module is switched on, the switching output is active.
6	2	Active between the two switching points
7	2	Inactive between the two switching points

You can set the switching behavior in the event of a short circuit/open circuit at the input (on/off/no response).

You can set the switch-on/switch-off delay in increments of 0.1 s from 0 s ... 10 s.

If an error is detected, the delay time is not taken into account.

8.3 Analog switching output

If you configure the device using one of the software or app solutions, this additional function is available. It allows you to implement a threshold value switch without having to integrate an extra switching output or use a separate threshold value switch.

The analog output can be used as an analog switching output. A low level or high level is output at the analog output. The low level or high level can be freely adjusted within the analog output range from 0 Hz ... 11 kHz or 0% ... 100%. The minimum distance between the two levels must be 10 Hz or 10%. The high level must be greater than the low level.

Switching points

The switching points are set finitely and in the selected unit (V, mA) and relate to the measuring input. In the case of a user characteristic curve, use the unit selected there.

A fixed mini hysteresis exists for each switching point, which is independent of the respective input signal. The mini hysteresis for the switching point is $\pm 0.1\%$ of the nominal input range.

The two switching points can be configured within the input signal range as follows.

Nominal measuring range	Input signal range
0 V ... 10 V	0.020 V ... 11.980 V
0 V ... 5 V	0.010 V ... 5.990 V
0 V ... 2.5 V	0.005 V ... 2.995 V
0 mA ... 20 mA	0.040 mA ... 23.960 mA
0 mA ... 10 mA	0.020 mA ... 11.980 mA
0 mA ... 5 mA	0.010 mA ... 5.990 mA

Switching points (including the mini hysteresis) must not exceed the maximum measuring range.

Switching behavior

Function of the switching output: signal high level after the switching point is exceeded; before this signal low level.

8.4 Monitoring

A monitoring function can be used with the software or app solutions. This means that you can display and note down current measured values via the software interface.

8.5 Limiting behavior of the analog output

In some applications it is important that the standard signal at the output remains within its limits. In the case of a 100 Hz ... 1000 Hz signal, for example, this means that the signal does not fall below 100 Hz or exceed 1000 Hz.

You can set this behavior under “Error signaling > Analog output > Limitation”. The best way to do this is via the software or app solutions.

If you configure the device via the DIP switches, you must select the combination with which the error signaling outputs the measuring range starting value as the value for underrange and the measuring range final value as the value for overrange.

8.6 Output response in the event of fast input signal change

In certain applications it can be important to respond immediately to changes to the input signal, before the end of a frequency period is reached. You can set this via the software or app under “Frequency output > Cancel period in the event of frequency change”. If the checkbox is not set, the frequency will not change until the current period has elapsed.

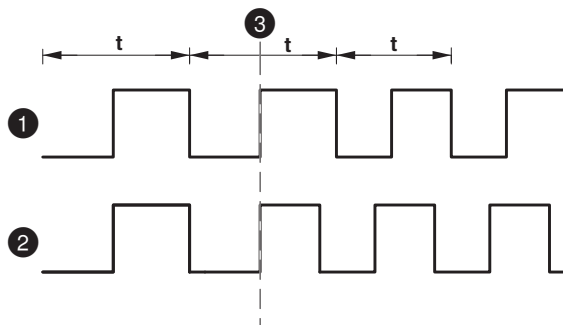

Figure 11 Output signals

1	Output signal changed once the entire period has elapsed
2	Output signal changed immediately
3	Input signal change

8.7 Diagnostic functions and error messages

Errors such as open circuit, short circuit, overrange, underrange, and module errors are detected by the modules. The errors are signaled via the analog output and/or the fault monitoring and/or, if present, via a switching output. At the same time, the error signaling is displayed by means of a red LED.

The respective error displays are removed when the error is eliminated.

The software and app solutions allow you to freely select and adjust all signaling variants.

If you configure the device via the DIP switches, you can choose between fixed signaling combinations (see configuration tables).

Analog input

A short circuit/open circuit in the current input can be detected if a live-zero signal is used (measuring range starts at 1 mA). A signal is defined as a short circuit/open circuit when it is less than 0.1% of the applicable nominal range.

A short circuit/open circuit in the voltage input can be detected if a live-zero signal is used (measuring range starts at 0.5 V). A signal is defined as a short circuit/open circuit when it is less than 0.1% of the applicable nominal range.

The settings options for signaling in the analog output or the switching output only appear in the software interfaces if a live-zero signal is set as described above.

8.8 Simulation mode/force

During startup it must be possible to specify analog values without a pending sensor signal from the field.

Analog signals can be simulated at the output with the software or app solutions.

You can set this behavior via “Service > Force analog output”. It can be specified as a percentage in relation to the set input or as an absolute value of the output signal range.

8.9 Measuring rate

With the measuring rate (sample rate) you can use the software solutions to achieve a higher device speed.

The following response times can be achieved for the analog output and the switching output.

Sample rate	Jump	Filter	Output	Response time	Transmission error
15 Hz	0 % ... 99.9 %	1	F/PWM output	approx. 120 ms	< 0.1 %
15 Hz	-	1	Switching output	approx. 130 ms	< 0.1 %
60 Hz	0 % ... 99.9 %	1	F/PWM output	approx. 35 ms	< 0.5%
60 Hz	-	1	Switching output	approx. 40 ms	< 0.5%
240 Hz	0 % ... 99.9 %	1	F/PWM output	approx. 15 ms	< 2 %
240 Hz	-	1	Switching output	approx. 20 ms	< 2 %

9 Diagnostics and status indicators

Green LED	PWR	Supply voltage
	Lit	Supply voltage present
Red LED	ERR	Fault display or simulation mode
	Flashing fast (2.8 Hz)	Sensor fault or invalid DIP switch configuration
	Flashing slowly (1.4 Hz)	Simulation mode
Yellow LED	Lit	Internal device error
	DO	Switch contact 1
	Lit	Switch contact 1 activated



Стандарт Электрон Связь

Мы молодая и активно развивающаяся компания в области поставок электронных компонентов. Мы поставляем электронные компоненты отечественного и импортного производства напрямую от производителей и с крупнейших складов мира.

Благодаря сотрудничеству с мировыми поставщиками мы осуществляем комплексные и плановые поставки широчайшего спектра электронных компонентов.

Собственная эффективная логистика и склад в обеспечивает надежную поставку продукции в точно указанные сроки по всей России.

Мы осуществляем техническую поддержку нашим клиентам и предпродажную проверку качества продукции. На все поставляемые продукты мы предоставляем гарантию .

Осуществляем поставки продукции под контролем ВП МО РФ на предприятия военно-промышленного комплекса России , а также работаем в рамках 275 ФЗ с открытием отдельных счетов в уполномоченном банке. Система менеджмента качества компании соответствует требованиям ГОСТ ISO 9001.

Минимальные сроки поставки, гибкие цены, неограниченный ассортимент и индивидуальный подход к клиентам являются основой для выстраивания долгосрочного и эффективного сотрудничества с предприятиями радиоэлектронной промышленности, предприятиями ВПК и научно-исследовательскими институтами России.

С нами вы становитесь еще успешнее!

Наши контакты:

Телефон: +7 812 627 14 35

Электронная почта: sales@st-electron.ru

Адрес: 198099, Санкт-Петербург,
Промышленная ул, дом № 19, литера Н,
помещение 100-Н Офис 331