

FEATURES

- TI OMAP-L138 Dual Core Application Processor
 - **456 MHz (Max) C674x VLIW DSP**
 - Floating Point DSP
 - 32 KB L1 Program Cache
 - 32 KB L1 Data Cache
 - 256 KB L2 cache
 - 1024 KB boot ROM
 - JTAG Emulation/Debug
 - **456 MHz (Max) ARM926EJ-S MPU**
 - 16 KB L1 Program Cache
 - 16 KB L1 Data Cache
 - 8 KB Internal RAM
 - 64 KB boot ROM
 - JTAG Emulation/Debug
- Up To 256 MB mDDR2 CPU RAM
- Up To 512 MB Parallel NAND FLASH
- 8 MB SPI based NOR FLASH
- Integrated Power Management
- Standard SO-DIMM-200 Interface
 - 10/100 EMAC MII / MDIO
 - 2 UARTS
 - 2 McBSPs
 - 2 USB Ports
 - Video Output
 - Camera/Video Input
 - MMC/SD
 - SATA
 - Single 3.3V Power Supply



(actual size)

APPLICATIONS

- Embedded Instrumentation
- Industrial Automation
- Industrial Instrumentation
- Medical Instrumentation
- Embedded Control Processing
- Network Enabled Data Acquisition
- Test and Measurement
- Software Defined Radio
- Bar Code Scanners
- Power Protection Systems
- Portable Data Terminals

BENEFITS

- Rapid Development / Deployment
- Multiple Connectivity and Interface Options
- Rich User Interfaces
- High System Integration
- Fixed & Floating Point Operations in Single CPU
 - High Level OS Support
 - Linux
 - QNX 6.4
 - Windows Embedded CE Ready
 - ThreadX Real Time OS
- Embedded Digital Signal Processing

DESCRIPTION

The MityDSP-L138 is a highly configurable, very small form-factor processor card that features a Texas Instruments OMAP-L138 456 MHz (max) Applications Processor (OMAP). The module includes FLASH (NAND, and NOR) and mDDR2 RAM memory subsystems. The MityDSP-L138 provides a complete and flexible digital processing infrastructure necessary for the most demanding embedded applications development.

The onboard OMAP-L138 processor provides a dual CPU core topology. The OMAP-L138 includes an ARM926EJ-S micro-processor unit (MPU) capable of running the rich software applications programmer interfaces (APIs) expected by modern system designers. The ARM architecture supports several operating systems, including linux and windows XP embedded. In addition to the ARM core, the OMAP-L138 also includes a TMS320C674x floating point digital signal processing (DSP) core. The DSP core supports the freely provided TI DSP/BIOS real-time kernel. Users can leverage the DSP to execute real-time compute algorithms (codecs, image/data processing, compression techniques, filtering, etc.)

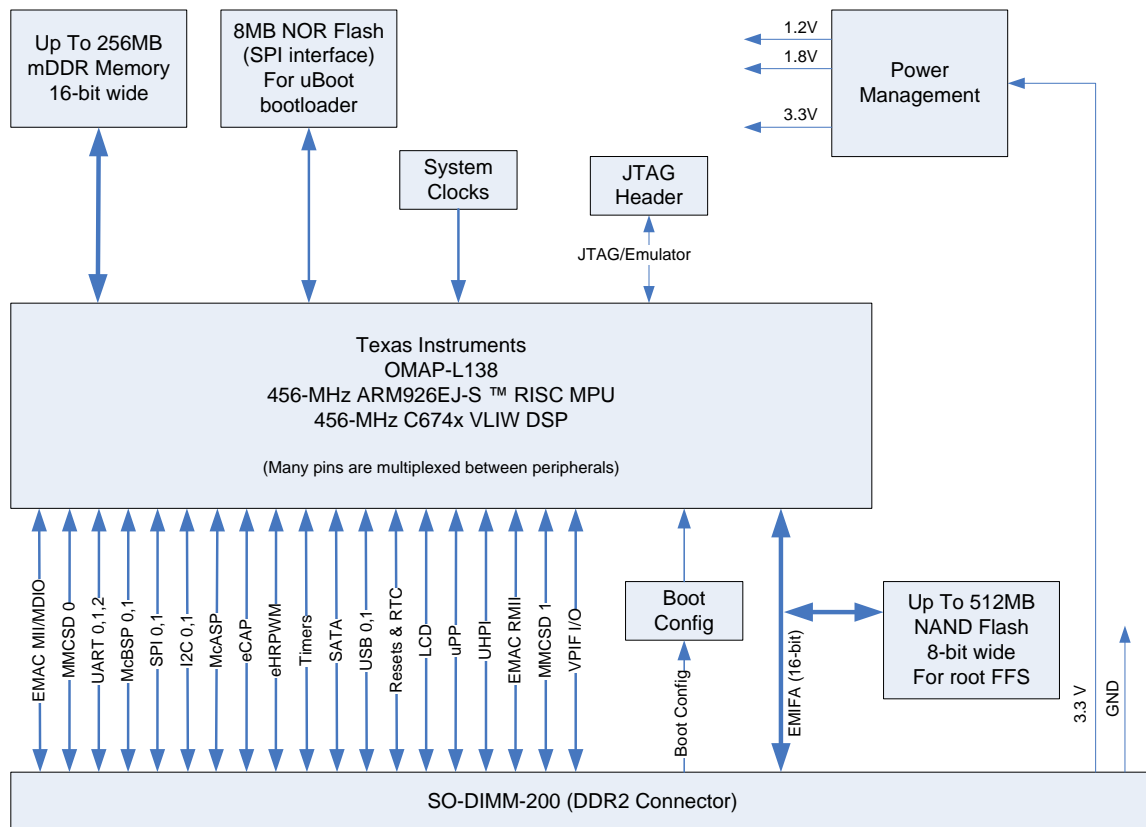

Figure 1 MityDSP-L138 Block Diagram

Figure 1 provides a top level block diagram of the MityDSP-L138 processor card. As shown in the figure, the primary interface to the MityDSP-L138 is through a standard SO-DIMM-200 card edge interface. The interface provides power, synchronous serial connectivity, and many other interfaces provided by the OMAP processor. Details of the SO-DIMM-200 connector interface are included in the SO-DIMM-200 Interface Description, below.

OMAP-L138 mDDR2 Memory Interface

The OMAP-L138 includes a dedicated DDR2 SDRAM memory interface shared between the onboard ARM and DSP cores. The MityDSP-L138 includes up to 256 MB of mDDR2 RAM integrated with the OMAP-L138 processor. The bus interface is capable of burst transfer rates of 600 MB / second. Note that the OSCIN frequency to the OMAP-L138 processor on the module is 24MHz.

OMAP-L138 SPI NOR FLASH Interface

The MityDSP-L138 includes 8 MB of SPI NOR FLASH. This FLASH memory is intended to store a factory provided bootloader, and typically a compressed image of a Linux kernel for the ARM core processor.

EMIFA - NAND FLASH / External Interface

Up to 512 MB of on-board NAND FLASH memory is connected to the OMAP-L138 using the EMIFA bus. The FLASH memory is 8 bits wide and is connected to third chip select line of the EMIFA (CE1). The FLASH memory is typically used to store the following types of data:

- ARM Linux / windows XP / QNX embedded root file-system
- FPGA application images
- runtime DSP or ARM software
- runtime application data (non-volatile storage)

The EMIFA bus is also accessible on the SO-DIMM connector. It can be used to access external memories such as SDRAM, SRAM, NOR flash, NAND flash, or memory-mapped ASICs and FPGAs. The interface is a maximum of 16-bits wide, but can also be used for 8-bit access. The interface has 14 dedicated address lines (plus 2 word/byte select lines), but up to 10 more are available if the MMCSDB0 interface is not used, or only partially used.

OMAP-L138 Camera and Video Interfaces

The OMAP-L138 includes an optional video port I/O interface commonly used to drive LCD screens as well as a camera input interface. These interfaces have been routed to the SO-DIMM-200 connector.

Debug Interface

Both the JTAG interface signals for the FPGA and the JTAG and emulator signals for the OMAP-L138 processor have been brought out to a Hirose header that is intended for use with an available Critical Link breakout adapter. This header can be removed for production units; please contact your Critical Link representative for details.

This adapter is not included with individual modules but is included with each Critical Link Development Kit that is ordered. If an adapter, Critical Link (CL) part number 80-000286, is needed please contact your Critical Link representative.

Software and Application Development Support

Users of the MityDSP-L138 are encouraged to develop applications using the MityDSP-L138 hardware and software development kit provided by Critical Link LLC. The development kit includes an implementation of an OpenEmbedded board support package providing an Angstrom based Linux distribution and compatible gcc compiler tool-chain with debugger. In addition, the development kit includes support libraries necessary to program the DSP core using the TI Code Composer Studio DSP compiler tool-chain.

The libraries provide the necessary functions needed to configure the MityDSP-L138, program standalone embedded applications, and interface with the various hardware components both on the processor board as well as a custom application carrier card. The libraries include several interface “cores” – DSP software modules designed to interface with various high performance data converter modules (ADCs, DACs, LCD and touchscreen interfaces, etc) – as well as bootloading and FLASH programming utilities.

Growth Options

The OMAP-L138 has been designed to support several upgrade options. These options include various speed grades, memory configurations, and operating temperature specifications including commercial and industrial temperature ranges. The available options are listed in the section below containing ordering information. For additional ordering information and details regarding these options, or to inquire about a particular configuration not listed below, please contact a Critical Link sales representative.

ABSOLUTE MAXIMUM RATINGS

If Military/Aerospace specified cards are required, please contact the Critical Link Sales Office or unit Distributors for availability and specifications.

Maximum Supply Voltage, Vcc 3.5 V

Storage Temperature Range -65 to 80C

Shock, Z-Axis ±10 g

Shock, X/Y-Axis ±10 g

OPERATING CONDITIONS

Ambient Temperature 0°C to 70°C

Range Commercial

Ambient Temperature -40°C to 85°C

Range Industrial

Humidity 0 to 95%

Non-condensing

MIL-STD-810F

Contact Critical Link for Details

SO-DIMM-200 Interface Description

The primary interface connector for the MityDSP-L138 is the SO-DIMM card edge interface which contains 4 classes of signals:

Power (PWR)

Dedicated signals mapped to the OMAP-L138 device (D)

Dedicated signals when NAND memory is populated on the module (D*)

Multi-function signals mapped to the OMAP-L138 device (M)

Table 1 contains a summary of the MityDSP-L138 pin mapping.

Table 1 SO-DIMM Pin-Out

Pin	Ball	Type	I/O	Signal	Pin	Ball	Type	I/O	Signal
1	-	PWR	-	+3.3 V in	2	-	PWR	-	+3.3 V in
3	-	PWR	-	+3.3 V in	4	-	PWR	-	+3.3 V in
5	-	PWR	-	+3.3 V in	6	-	PWR	-	+3.3 V in
7	-	PWR	-	GND	8	-	PWR	-	GND
9	-	PWR	-	GND	10	-	PWR	-	GND
11	K14	D	I	RESET_IN#	12	-	D	I	EXT_BOOT#
13	J1	D	O	SATA_TX_P	14	A4	M	I/O	GP0_7
15	J2	D	O	SATA_TX_N	16	A3	M	I/O	GP0_10
17	L1	D	I	SATA_RX_P	18	A2	M	I/O	GP0_11
19	L2	D	I	SATA_RX_N	20	A1	M	I/O	GP0_15
21	P16	D	I	USB0_ID	22	B4	M	I/O	GP0_6
23	P18	D	I/O	USB1_D_N	24	B1	M	I/O	GP0_14
25	P19	D	I/O	USB1_D_P	26	B2	M	I/O	GP0_12
27	N19	D	O	USB0_VBUS	28	B3	M	I/O	GP0_5
29	M18	D	I/O	USB0_D_N	30	C2	M	I/O	GP0_13
31	M19	D	I/O	USB0_D_P	32	C3	M	I/O	GP0_1
33	K18	D	O	USB0_DRVVBUS	34	C4	M	I/O	GP0_4
35	-	D	-	3V RTC Battery	36	C5	M	I/O	GP0_3
37	-	PWR	-	+3.3 V in	38	-	PWR	-	+3.3 V in
39	-	PWR	-	+3.3 V in	40	-	PWR	-	+3.3 V in

Pin	Ball	Type	I/O	Signal	Pin	Ball	Type	I/O	Signal
41	-	PWR	-	GND	42	-	PWR	-	GND
43	H17	D	I/O	SPI1_MISO	44	D4	M	I/O	GP0_2
45	G17	D	I/O	SPI1_MOSI	46	E4	M	I/O	GP0_0
47	H16	D	I/O	SPI1_ENA	48	F4	M	I/O	GP0_8
49 ¹	G19	D	I/O	SPI1_CLK	50	D5	M	I/O	GP0_9
51	F18	M	I/O	SPI1_SCS[1]	52	A12	M	I/O	MMCSD0_DAT[7]
53	-	D	-	Reserved	54	C11	M	I/O	MMCSD0_DAT[6]
55 ²	G16	D	I/O	I2C0_SCL	56	E12	M	I/O	MMCSD0_DAT[5]
57 ²	G18	D	I/O	I2C0_SDA	58	B11	M	I/O	MMCSD0_DAT[4]
59	F16	M	I/O	UART2_TXD / I2C1_SDA	60	E11	M	I/O	MMCSD0_DAT[3]
61	F17	M	I/O	UART2_RXD / I2C1_SCL	62	C10	M	I/O	MMCSD0_DAT[2]
63	-	PWR	-	GND	64	-	PWR	-	GND
65	F19	M	O	UART1_TXD	66	A11	M	I/O	MMCSD0_DAT[1]
67	E18	M	I	UART1_RXD	68	B10	M	I/O	MMCSD0_DAT[0]
69	E16	M	O	MDIO_CLK	70	A10	M	I/O	MMCSD0_CMD
71	D17	M	I/O	MDIO_D	72	E9	M	O	MMCSD0_CLK
73	D19	M	I	MII_RXCLK	74	D3	M	I	MII_TXCLK
75	C17	M	I	MII_RXDV	76	E3	M	O	MII_TXD[3]
77	D16	M	I	MII_RXD[0]	78	E2	M	O	MII_TXD[2]
79	E17	M	I	MII_RXD[1]	80	E1	M	O	MII_TXD[1]
81	D18	M	I	MII_RXD[2]	82	F3	M	O	MII_TXD[0]
83	C19	M	I	MII_RXD[3]	84	C1	M	O	MII_TXEN
85	-	PWR	-	GND	86	-	PWR	-	GND
87	C18	M	I	MII_CRS	88	D1	M	I	MII_COL
89	C16	M	I	MII_RXER	90	-	D	-	NC
91	A18	M	O	EMA_CS[0]	92	W15	M	I/O	UPP_CHA_START
93	B15	D*	O	EMA_OE	94	V15	M	I	VP_CLKIN1
95	C15	M	O	EMA_BA[0]	96	U18	M	I/O	UPP_D[15] / RMII_TXD[1]
97	A15	M	O	EMA_BA[1]	98	V16	M	I/O	UPP_D[14] / RMII_TXD[0]
99	C14	M	O	EMA_A[0]	100	R14	M	I/O	UPP_D[13] / RMII_TXEN
101	D15	D*	O	EMA_A[1]	102	W16	M	I/O	UPP_D[12] / RMII_RXD[1]
103	B14	D*	O	EMA_A[2]	104	V17	M	I/O	UPP_D[11] / RMII_RXD[0]
105	D14	M	O	EMA_A[3]	106	W17	M	I/O	UPP_D[10] / RMII_RXER
107	-	PWR	-	GND	108	-	PWR	-	GND
109	A14	M	O	EMA_A[4]	110	W18	M	I/O	UPP_D[9] / RMII_REF_CLK
111	C13	M	O	EMA_A[5]	112	W19	M	I/O	UPP_D[8] / RMII_CRS_DV
113	E13	M	O	EMA_A[6]	114	V18	M	I/O	UPP_D[7]
115	B13	M	O	EMA_A[7]	116	V19	M	I/O	UPP_D[6]
117	A13	M	O	EMA_A[8]	118	U16	M	I/O	UPP_CHA_ENABLE
119	D12	M	O	EMA_A[9]	120	U19	M	I/O	UPP_D[5]
121	C12	M	O	EMA_A[10]	122	T16	M	I/O	UPP_D[4]
123	B12	M	O	EMA_A[11]	124	R18	M	I/O	UPP_D[3]
125	D13	M	O	EMA_A[12]	126	R19	M	I/O	UPP_D[2]
127	D11	M	O	EMA_A[13]	128	T15	M	I/O	UPP_CHA_WAIT
129	-	PWR	-	GND	130	-	PWR	-	GND
131	E6	D*	I/O	EMA_D[15]	132	R15	M	I/O	UPP_D[1]
133	C7	D*	I/O	EMA_D[14]	134	P17	M	I/O	UPP_D[0]
135	B6	D*	I/O	EMA_D[13]	136	U17	M	I/O	UPP_CHA_CLK
137	A6	D*	I/O	EMA_D[12]	138	J4	M	I/O	UPP_CHB_ENABLE
139	D6	D*	I/O	EMA_D[11]	140	K3	M	O	VP_CLKOUT2
141	A7	D*	I/O	EMA_D[10]	142	H3	M	I	VP_CLKIN2



Pin	Ball	Type	I/O	Signal	Pin	Ball	Type	I/O	Signal
143	D9	D*	I/O	EMA_D[9]	144	G3	M	I/O	UPP_CHB_WAIT
145	E10	D*	I/O	EMA_D[8]	146	G2	M	I/O	UPP_CHB_START
147	D7	D*	I/O	EMA_D[7]	148	G1	M	I/O	UPP_CHB_CLK
149	C6	D*	I/O	EMA_D[6]	150	W14	M	I	VP_CLKIN0
151	-	PWR	-	GND	152	-	PWR	-	GND
153	E7	D*	I/O	EMA_D[5]	154	P4	M	I/O	LCD_D[15]
155	B5	D*	I/O	EMA_D[4]	156	R3	M	I/O	LCD_D[14]
157	E8	D*	I/O	EMA_D[3]	158	R2	M	I/O	LCD_D[13]
159	B8	D*	I/O	EMA_D[2]	160	R1	M	I/O	LCD_D[12]
161	A8	D*	I/O	EMA_D[1]	162	T3	M	I/O	LCD_D[11]
163	C9	D*	I/O	EMA_D[0]	164	T2	M	I/O	LCD_D[10]
165	C8	M	O	EMA_WEN_DQM[0]	166	T1	M	I/O	LCD_D[9]
167	A5	M	O	EMA_WEN_DQM[1]	168	U3	M	I/O	LCD_D[8]
169	D8	M	O	EMA_SDCKE	170	U2	M	I/O	LCD_D[7]
171 ³	B7	M	O	EMA_CLK	172	U1	M	I/O	LCD_D[6]
173	-	PWR	-	GND	174	-	PWR	-	GND
175	B9	D*	O	EMA_WE	176	G4	M	O	LCD_VSYNC
177	A9	M	O	EMA_CAS	178	H4	M	O	LCD_HSYNC
179	A16	M	O	EMA_RAS	180	V3	M	I/O	LCD_D[5]
181	B17	M	O	EMA_CS[2]	182	F1	M	O	LCD_PCLK
183	F9	M	O	EMA_CS[4]	184	V2	M	I/O	LCD_D[4]
185	B16	M	O	EMA_CS[5]	186	V1	M	I/O	LCD_D[3]
187	T17	D	O	RESET_OUT	188	W3	M	I/O	LCD_D[2]
189	J3	M	I	VP_CLKIN3	190	W2	M	I/O	LCD_D[1]
191	K4	M	O	VP_CLKOUT3	192	W1	M	I/O	LCD_D[0]
193	F2	M	O	LCD_MCLK	194	R5	M	O	LCD_AC_ENB_CS
195	-	PWR	-	GND	196	-	PWR	-	GND
197 ⁴	D10	M	O	EMA_A_RW	198	B18 ⁴	D*	I	EMA_WAIT[0]
199 ⁴	A17	D*	O	EMA_CS[3]	200	B19 ⁴	M	I	EMA_WAIT[1]

Note 1: Pin 49, SPI1_CLK, has a 100K Ohm pull-down resistor on the module

Note 2: Pins 55 and 57 have 4.70K pull-up resistors on the module

Note 3: Pin 171, EMA_CLK, has a 49.9 Ohm resistor in series with the signal on the module

Note 4: Pins 197, 198, 199 and 200 have 1.00K Ohm resistors in series with the signals on the module

The signal group description for the above pins is included in Table 2

Table 2 Signal Group Description

Signal / Group	Type	Description
3.3 V in	N/A	3.3 volt input power referenced to GND.
EXT_BOOT#	I	Bootstrap configuration pin. Pull low to configure booting from external UART1.
RESET_IN#	I	Manual Reset. When pulled to GND for a minimum of 1 usec, resets the processor.

Signal / Group	Type	Description
SPI1_*	I/O	Serial Peripheral Interface 1 pins. These pins are direct connects to the corresponding SPI1_* pins on the OMAP-L138 processor. The SPI1_* function pins are multiplexed with other functions. These include PWM, Timers, UARTs, I2C0, and GPIO. For details please refer to the OMAP-L138 processor specifications.
MII_*	I/O	Media Independent Interface (Ethernet) pins. These pins are direct connects to the corresponding MII_* pins on the OMAP-L138 processor. The MII_* function pins are multiplexed with other functions. These include SPI0, PWM, Timers, UART0, MCBSP, MCASP, and GPIO. For details please refer to the OMAP-L138 processor specifications.
MDIO_DAT MDIO_CLK	I/O	MII/RMII Management Interface pins. The MDIO_CLK and MDIO_DAT signals are direct connects to the corresponding MDIO_* signals on the OMAP-L138 processor. The MDIO_* function pins are multiplexed with other functions. These include SPI0 and Timer functions. For details please refer to the OMAP-L138 processor specifications.
GP0_*	I/O	General Purpose / multiplexed pins. These pins are direct connects to the corresponding GP0[*] pins on the OMAP-L138 processor. The include support for the McASP, general purpose I/O, UART flow control, and McBSP 1. For details please refer to the OMAP-L138 processor specifications.
SATA_TX_P SATA_TX_N	O	Serial ATA Controller Transmit pins. These pins are direct connects to the corresponding SATA_TX_* pins on the OMAP-L138 processor. For details please refer to the OMAP-L138 processor specifications.
SATA_RX_P SATA_RX_N	I	Serial ATA Controller Receive pins. These pins are direct connects to the corresponding SATA_RX_* pins on the OMAP-L138 processor. For details please refer to the OMAP-L138 processor specifications.
GND	N/A	System Digital Ground.
EMA_*	I/O	EMIF-A pins. These pins are direct connects to the corresponding EMA_* pins on the OMAP-L138 processor. Alternatively, these pins can be configured as GPIOs for modules that do not have NAND memory present. For details please refer to the OMAP-L138 processor specifications. Note that pins 197, 198, 199 and 200 have 1.00K Ohm resistors in series with the signals on the module.

Signal / Group	Type	Description
UPP_*	I/O	Universal Parallel Port pins. These pins are direct connects to the corresponding UPP_* pins on the OMAP-L138 processor. The UPP_* function pins are multiplexed with other functions. These include RMII, VP_DIN, MMCSD1, and GPIO. For details please refer to the OMAP-L138 processor specifications.
RMII_*	I/O	Reduced Media Independent Interface pins. These pins are direct connects to the corresponding RMII_* pins on the OMAP-L138 processor. The RMII_* function pins are multiplexed with other functions. These include UPP and VP_DIN. For details please refer to the OMAP-L138 processor specifications.
LCD_*	I/O	Liquid Crystal Display pins. These pins are direct connects to the corresponding LCD_* pins on the OMAP-L138 processor. The LCD_* function pins are multiplexed with other functions. These include VP_DOUT, UPP, MMCSD1, and GPIO. For details please refer to the OMAP-L138 processor specifications.
VP_*	I/O	Video Port In/Out. These pins are direct connects to the corresponding VP_* pins on the OMAP-L138 processor. The VP_* function pins are multiplexed with other functions. These include UPP, MMCSD1, and GPIO. For details please refer to the OMAP-L138 processor specifications.
RESET_OUT	I/O	Reset Output pin. This pin is a direct connect to the RESET_OUT pin on the OMAP-L138 processor. This pin can also be configured as a GPIO. For details please refer to the OMAP-L138 processor specifications.
USB0_*, USB1_*	I/O	Universal Serial Bus 0 / 1 pins. These pins are direct connects to the corresponding USB_* pins on the OMAP-L138 processor. For details please refer to the OMAP-L138 processor specifications.

DEBUG INTERFACE

Below is the pin-out for the Hirose 31 pin header (DF9-31P-1V(32)) that interfaces with an available adapter board, CL part number 80-000286, to debug the OMAP-L138.

Debug Interface Connector Description (J2)

Table 3 OMAP-L138 Hirose Connector

Pin	I/O	Signal	Pin	I/O	Signal
1	-	GND	2	O	OMAP EMU1
3	-	GND	4	O	OMAP EMU0
5	-	GND	6	I	OMAP TCK
7	-	GND	8	O	OMAP RTCK
9	-	GND	10	O	OMAP TDO
11	-	GND	12	-	OMAP VCC / 3.3V
13	-	GND	14	I	OMAP TDI
15	-	GND	16	I	OMAP TRST
17	-	GND	18	I	OMAP TMS
19	-	GND	20	-	GND
21	-	GND	22	NC	FPGA VREF / VCCAUX
23	-	GND	24	NC	FPGA TMS
25	-	GND	26	NC	FPGA TCK
27	-	GND	28	NC	FPGA TDO
29	-	GND	30	NC	FPGA TDI
31	-	GND			

ELECTRICAL CHARACTERISTICS

Table 4: Electrical Characteristics

Symbol	Parameter	Conditions	Min	Typ	Max	Units
V33	Voltage supply, 3.3 volt input.		3.2	3.3	3.4	Volts
I33	Quiescent Current draw, 3.3 volt input		170	230	250	mA
I33-max	Max current draw, positive 3.3 volt input.			300	TBS	mA
FCPU	CPU internal clock Frequency (PLL output)		96	300	456	MHz
FEMIF	EMIF bus frequency	Must be $\leq \frac{1}{2}$ CPU	-	100	-	MHz
1. Power utilization of the MityDSP-L138 is heavily dependent on end-user application. Major factors include: ARM CPU PLL configuration, DSP Utilization FPGA utilization, and external DDR2 RAM utilization.						

ORDERING INFORMATION

The following table lists the standard module configurations. For shipping status, availability, and lead time of these or other configurations please contact your Critical Link representative.

Table 5: Standard Model Numbers

Model	ARM and DSP Speed	FPGA	NOR Flash	NAND Flash	RAM	Operating Temp
L138-DX-225-RI	375 MHz	N/A	8MB	256MB	128MB	-40°C to 85°C
L138-FX-225-RC	456 MHz	N/A	8MB	256MB	128MB	0°C to 70°C
L138-FX-236-RC	456 MHz	N/A	8MB	512MB	256MB	0°C to 70°C

MECHANICAL INTERFACE

A mechanical outline of the MityDSP-L138 is illustrated in Figure 2, below.

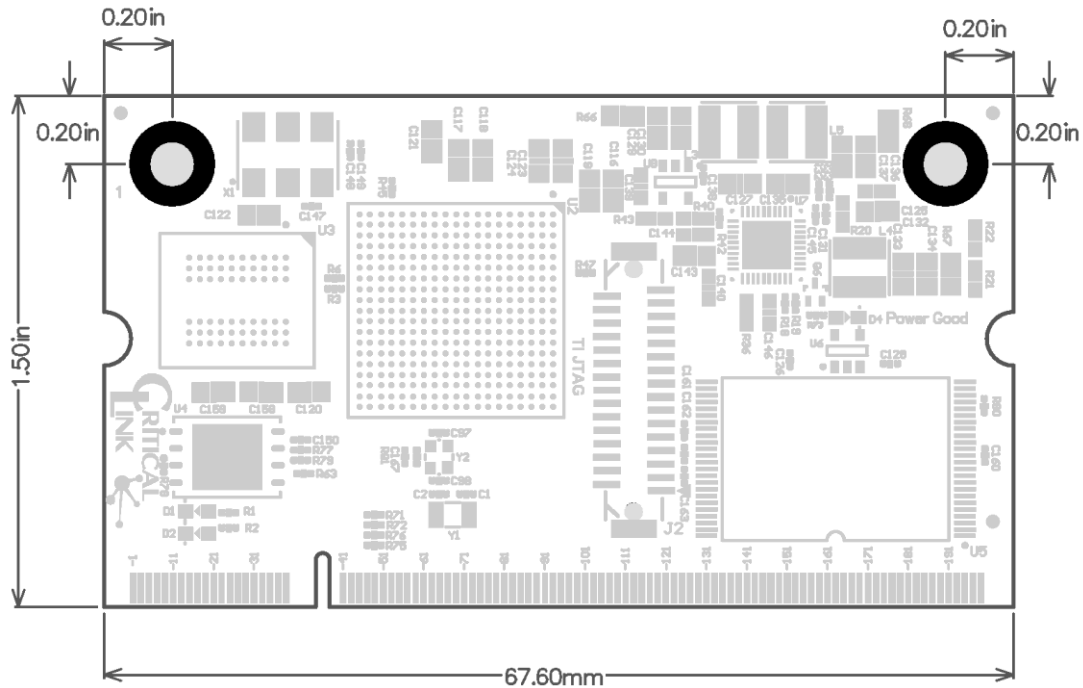

Figure 2 MityDSP-L138 Mechanical Outline

REVISION HISTORY

Date	Change Description
31-DEC-2010	Initial revision.
11-FEB-2011	Update picture. Update Table 1. Change to 456 MHz max speed. Change DDR bandwidth to support 150 MHz clocking. Update model number table.
12-JUL-2011	Update NAND to indicate 8 bit data width. Update block diagram accordingly.
17-FEB-2012	Updated ordering information.
11-DEC-2012	Update Debug Header information, added MIL-STD-810F and Up To notation for RAM and NAND
27-MAR-2013	Added OMAP-L138 processor pins with notes about on module resistors for specific pins as well as the OSCIN frequency.



Стандарт Электрон Связь

Мы молодая и активно развивающаяся компания в области поставок электронных компонентов. Мы поставляем электронные компоненты отечественного и импортного производства напрямую от производителей и с крупнейших складов мира.

Благодаря сотрудничеству с мировыми поставщиками мы осуществляем комплексные и плановые поставки широчайшего спектра электронных компонентов.

Собственная эффективная логистика и склад в обеспечивает надежную поставку продукции в точно указанные сроки по всей России.

Мы осуществляем техническую поддержку нашим клиентам и предпродажную проверку качества продукции. На все поставляемые продукты мы предоставляем гарантию .

Осуществляем поставки продукции под контролем ВП МО РФ на предприятия военно-промышленного комплекса России , а также работаем в рамках 275 ФЗ с открытием отдельных счетов в уполномоченном банке. Система менеджмента качества компании соответствует требованиям ГОСТ ISO 9001.

Минимальные сроки поставки, гибкие цены, неограниченный ассортимент и индивидуальный подход к клиентам являются основой для выстраивания долгосрочного и эффективного сотрудничества с предприятиями радиоэлектронной промышленности, предприятиями ВПК и научно-исследовательскими институтами России.

С нами вы становитесь еще успешнее!

Наши контакты:

Телефон: +7 812 627 14 35

Электронная почта: sales@st-electron.ru

Адрес: 198099, Санкт-Петербург,
Промышленная ул, дом № 19, литера Н,
помещение 100-Н Офис 331