

Two vertical bars on the left side of the page: a yellow one on top and a green one below it.

VisionSOM-RT Datasheet and Pinout

Rev. 20200401074826

Source URL: http://wiki.somlabs.com/index.php/VisionSOM-RT_Datasheet_and_Pinout

Table of Contents

General description	1
Applications	1
Features	3
Pictures of SOM versions	4
Ordering info	5
Block Diagram	6
Operating ranges	8
Electrical parameters	9
Pinout	10
Dimensions	17

VisionSOM-RT Datasheet and Pinout

General description

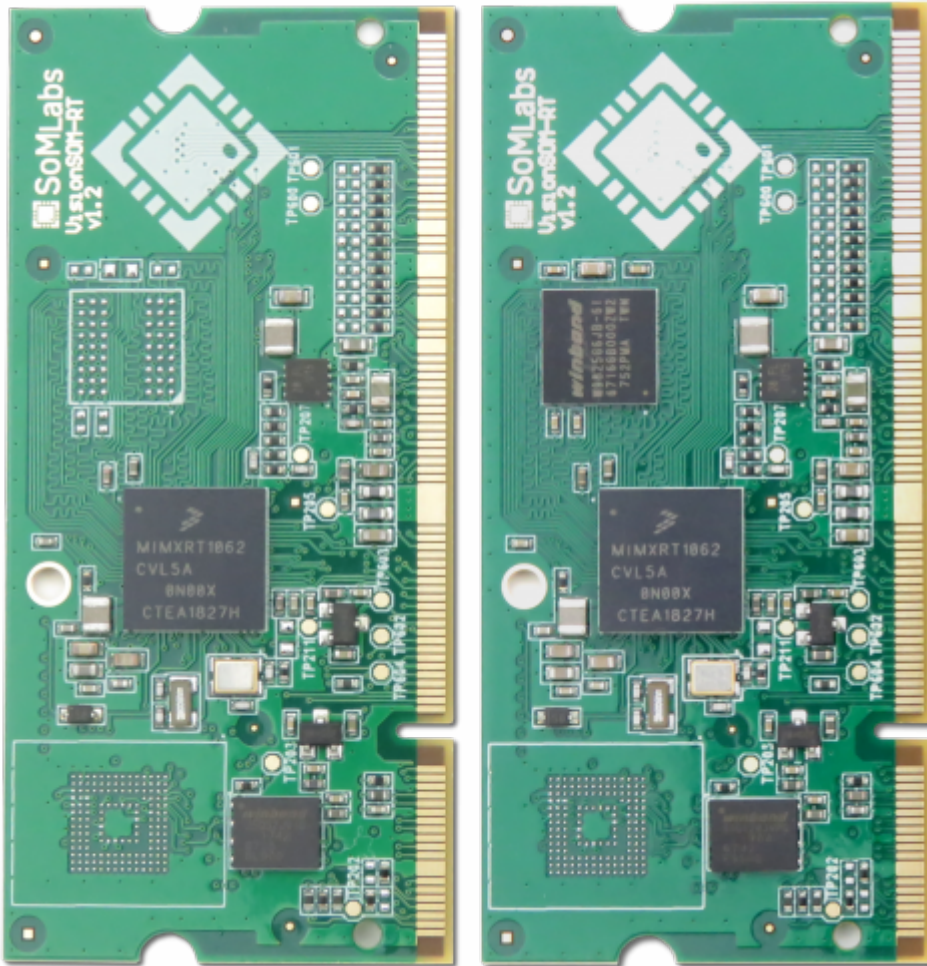

The VisionSOM-RT family is a SODIMM-sized SoM based on the NXP i.MX RT application processor which features an advanced implementation of a single ARM Cortex-M7 core (at speeds up to 600MHz).

The VisionSOM-RT is a low power highly integrated SoM (System-on-Module) featuring high computation performance, real-time functionality and MCU usability. High security enabled by AES-128, HAB and On-the-fly QSPI Flash Decryption together with 2D graphical acceleration make an ideally suited solution for home and industrial control systems, wireless application, communication solutions and real-time systems.

The system supports industrial grade targeting embedded application.

SoMLabs also provides a complete hardware and software development board for the SoM in the form of a carrier board and optional TFT display and touch panel.

Applications

- Industrial embedded RTOS computer
- Home Appliances

- Home Automation - Smart Home
- Human-machine Interfaces (HMI)
- Point-of-sales (POS) terminals
- Cash Register
- 2D barcode scanners and printers
- Smart grid Infrastructure
- IoT gateways
- Residential gateways
- Machine vision equipment
- Robotics
- Fitness/outdoor equipment

Features

- Powered by NXP i.MX RT application processor
- Core clock up to 600MHz
- 512kB on-chip RAM memory
- 256Mb (32MB) SDRAM memory
- 128Mb (16MB) QuadSPI Flash memory
- Power-efficient and cost-optimized solution
- Ideal for industrial IoT and embedded applications
- FreeRTOS support

Pictures of SOM versions

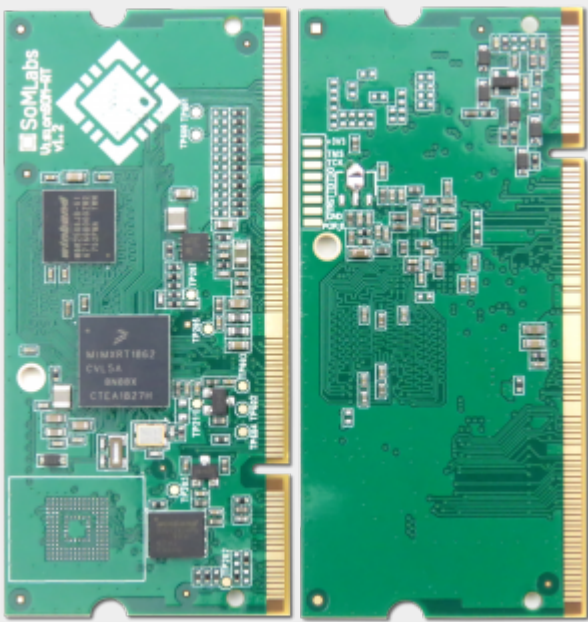
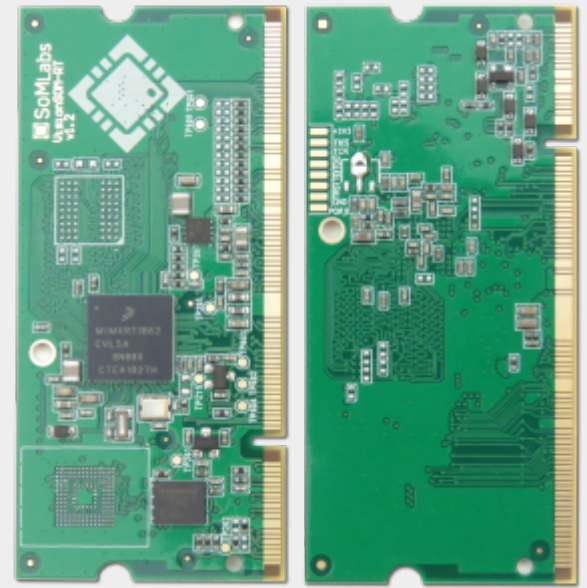
Version	Photo
RAM&QSPI	
QSPI	

Ordering info

SLSN2CpuType_Clock_RamSize_FlashSize_SF_TEMP_V

SLS	Product type SLS - System on Module
N	SOM Name 1 - VisionSOM SODIMM200
2	CPU Family 2 - i.MX RT
CpuType	CPU Type RT52 - i.MX RT 1052 RT62 - i.MX RT 1062
Clock	CPU Clock Speed 528C - 528MHz
RamSize	RAM Size 0R - No RAM 32R - 32MB
FlashSize	Flash Size Type and Density 4QSPI - 4MB QSPI Flash 16QSPI - 16MB QSPI Flash
SF	Special Features 0SF - No Special Features
TEMP	Operating Temperature C - Consumer: 0 to +70 C I - Industrial: -40 to +85 C
V	SOM Version A - Version 1.2

Block Diagram

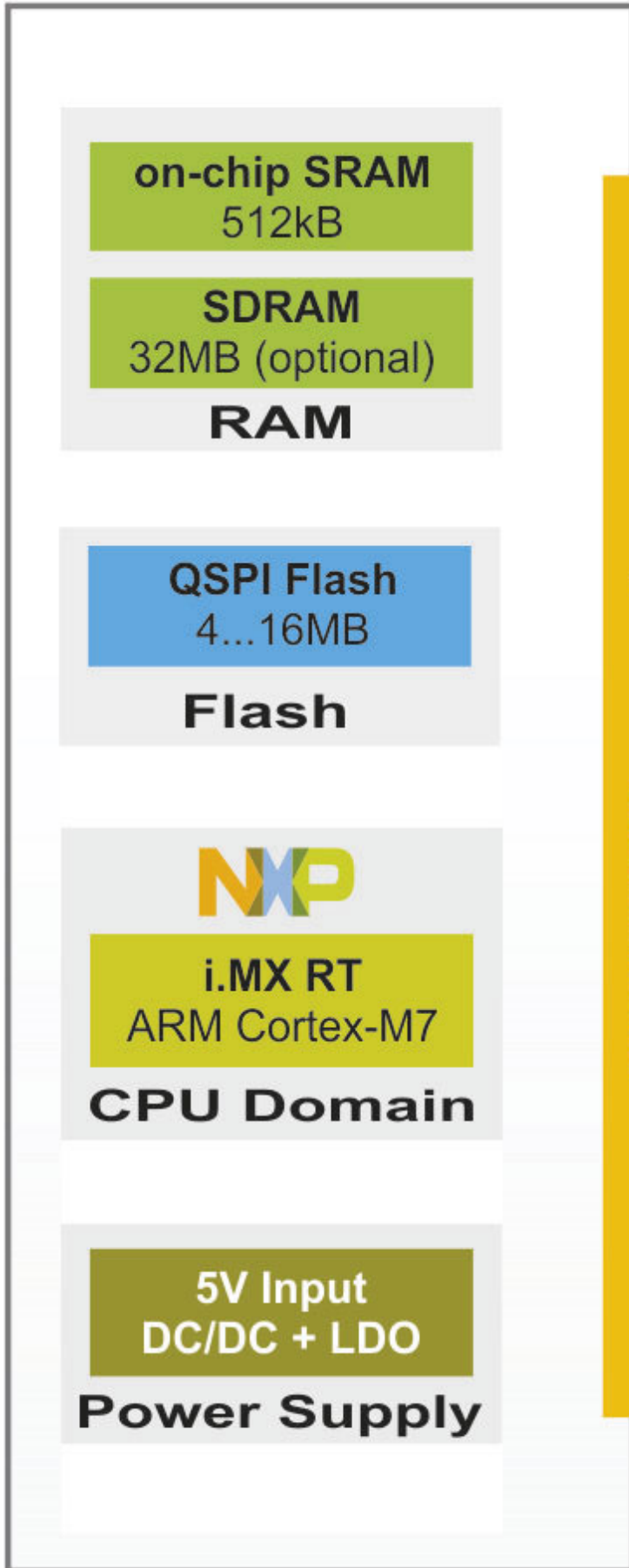

Operating ranges

Parameter	Value	Unit	Comment
Power Supply	5.0	V	Connected to +5VIN SODIMM pin
Internal LDO output voltage	3.3	V	Generated by internal LDO
Internal LDO output current	500	mA	Maximum value
Input GPIO voltage	0...+3.3	V	-
Environment temperature ¹	-40...+85	°C	Industrial range
	0...+70		Consumer range

Note:

1. Maximum MPU junction temperature is +105°C (industrial version) or +95°C (consumer version).

Electrical parameters

SOM signal name	Parameter	Value			Units
		Min.	Typ.	Max.	
+5VIN	Supply Voltage	4.0	5.0	5.5	V
-	Total Supply Current ¹	-	80	150	mA
VGPI0	GPIO Input Voltage	0	3.3	3.6 ²	V
+3.3VOUT	SOM Internal LDO Output Current	-	-	0.5	A
USB-OTGx-VBUS	USB Supply	4.40	-	5.5	V
VDD-COIN-3V	SNVS Backup Battery Supply	2.66	-	3.6	V
-	ADC Inputs Voltage	0	-	3.3	V

Notes:

1. Excluding external load connected to +3.3VOUT lines.
2. Applying the maximum voltage 3.6V results in shorten lifetime. Recommended value is smaller than 3.5V.

Pinout

Important notes: Important notes

1. Detail pin configurations description you can find, edit and arrange in dedicated MEX files (with free "i.MX Pin Tool" configurational tool): [VisionSOM-RT52 with QSPI Flash memory on board](#) or [VisionSOM-RT52 with eMMC Flash memory on board](#)
2. LCD_DATAxx pins are internally used for boot sequence configuration. We recommend to use LCD_DATAxx lines as outputs or using eFuse boot configuration.
3. Internal peripherals and pin functions depends on i.MX-RT version (i.a. in RT1052 there is just one Ethernet channel). Description in table fits to RT1052 model.

SODIMM pin	Functional domain	Function name	i.MX-RT pad name	Description (refer to i.MX-RT manuals for details)
1	Power	GND	-	-
2	Power	GND	-	-
3	Ctrl	PMIC-STBY-REQ	CCM_PMIC_STBY_REQ	Output, leave open if not used.
4	Ctrl	POR-B	-	External warm reset input, active L.
5	Ctrl	PMIC-ON-REQ	SNVS_PMIC_ON_REQ	Output, leave open if not used.
6	Power	VDD-SNVS-3V3	VDD_SNVS_IN	SNVS backup power supply must be held between 2.9V and 3.3V if the system requires keeping real time and other data on OFF state. Internally connected to +3.3V, leave open.
7	BOOT	BOOT1	GPIO_AD_B0_05	BOOT1 configuration line or multifunction GPIO with 3.3V logic levels. By default this line is pulled-up with 1k resistor.
8	Power	VDD-COIN-3V	VDD_SNVS_IN	Optional external coin battery for SNVS power domain, must be held between 2.9V and 3.3V if the system requires keeping real time and other data on OFF state. Leave open if not used.
9	BOOT	BOOT0	GPIO_AD_B0_04	BOOT1 configuration line or multifunction GPIO with 3.3V logic levels. Pin shared with GPIO-B0-04 line. By default this line is pulled-down with 10k resistor.
10	NC	-	-	Not internally connected.
11	USB	USB-OTG2-VBUS	USB_OTG2_VBUS	+5V USB bus. Leave open if not used.
12	NC	-	-	Not internally connected.
13	USB	USB-OTG1-VBUS	USB_OTG1_VBUS	+5V USB bus. Leave open if not used.
14	Ctrl	ONOFF	ONOFF	Input for power interrupt generation. Leave open if not used.
15	Power	GND	-	-
16	Ctrl	POR-B	POR_B	Cold reset negative logic input resets all modules and logic in the IC. May be used in addition to internally generated power on reset signal (logical AND, both internal and external signals are considered active low).
17	Power	GND	-	-
18	NC	-	-	Not internally connected.
19	USB	USB-OTG2-DP	USB_OTG2_DP	Leave open if not used.
20	Power	GND	-	-
21	USB	USB-OTG2-DN	USB_OTG2_DN	Leave open if not used.
22	Power	GND	-	-
23	Power	GND	-	-

24	NC	-	-	Not internally connected.
25	USB	USB-OTG1-DP	USB_OTG1_DP	Leave open if not used.
26	Power	GND	-	-
27	USB	USB-OTG1-DN	USB_OTG1_DN	Leave open if not used.
28	Power	GND	-	-
29	Power	GND	-	-
30	NC	-	-	Not internally connected.
31	USB	nUSB-OTG-CHD	USB_OTG1_CHD_B	Leave open if not used.
32	NC	-	-	Not internally connected.
33	JTAG	JTAG-MOD	GPIO_AD_B0_08	JTAG mode selector. multifunction GPIO with 3.3V levels. Leave open if not used (built-in 4.7k pull-down resistor).
34	NC	-	-	Not internally connected.
35	Power	GND	-	-
36	NC	-	-	Not internally connected.
37		CLK1-N	CCM_CLK1_N	General purpose differential high speed clock input/output. Leave open if not used.
38	Power	GND	-	-
39		CLK1-P	CCM_CLK1_P	General purpose differential high speed clock input/output. Leave open if not used.
40	Power	GND	-	-
41	Power	GND	-	-
42	NC	-	-	Not internally connected.
43	JTAG	JTAG-TDI	GPIO_AD_B0_09	JTAG TDI input line. Multifunction GPIO with 3.3V logic levels.
44	NC	-	-	Not internally connected.
45	GPIO	GPIO-B1-09	GPIO_AD_B1_09	Multifunction GPIO with 3.3V logic levels.
46	JTAG	JTAG-TMS	GPIO_AD_B0_06	JTAG TMS input line. Multifunction GPIO with 3.3V logic levels.
47	GPIO	GPIO-B0-04	GPIO_AD_B0_04	Multifunction GPIO with 3.3V logic levels. Pin shared with BOOT-MODE0 line.
48	JTAG	JTAG-nTRST	GPIO_AD_B0_11	JTAG nTRST input line. Multifunction GPIO with 3.3V logic levels.
49	GPIO	GPIO-B1-11	GPIO_AD_B1_11	Multifunction GPIO with 3.3V logic levels.
50	Power	GND	-	-
51	Power	GND	-	-
52	JTAG	JTAG-TDO	GPIO_AD_B0_10	JTAG TDO output line. Multifunction GPIO with 3.3V logic levels.
53	GPIO	ENET-MDC	GPIO_EMC_40	Multifunction GPIO with 3.3V logic levels.
54	JTAG	JTAG-TCK	GPIO_AD_B0_07	JTAG TCK input line. Multifunction GPIO with 3.3V logic levels.
55	GPIO	GPIO-B0-03	GPIO_AD_B0_03	Multifunction GPIO with 3.3V logic levels.
56	GPIO	GPIO-B1-14	GPIO_B1_14	Multifunction GPIO with 3.3V logic levels.
57	COM-GPIO	UART1-TXD	GPIO_AD_B0_12	UART1 TxD output multifunction GPIO with 3.3V logic levels.
58	GPIO	GPIO-B0-02	GPIO_AD_B0_02	Multifunction GPIO with 3.3V logic levels.
59	Power	GND	-	-
60	Power	GND	-	-
61	GPIO	ENET-MDIO	GPIO_EMC_41	Multifunction GPIO with 3.3V logic levels.

62	GPIO	GPIO-B0-01	GPIO_AD_B0_01	Multifunction GPIO with 3.3V logic levels.
63	COM-GPIO	UART1-RXD	GPIO_AD_B0_13	UART1 RxD inputor multifunction GPIO with 3.3V logic levels.
64	GPIO	GPIO-B0-00	GPIO_AD_B0_00	Multifunction GPIO with 3.3V logic levels.
65	COM-GPIO	UART2-TXD	GPIO_AD_B1_02	UART2 TxD outputor multifunction GPIO with 3.3V logic levels.
66	COM-GPIO	UART1-CTS	GPIO_AD_B0_14	UART1 CTS outputor multifunction GPIO with 3.3V logic levels.
67	COM-GPIO	UART2-RXD	GPIO_AD_B1_03	UART2 RxD inputor multifunction GPIO with 3.3V logic levels.
68	COM-GPIO	UART5-RXD	GPIO_B1_13	UART5 RxD inputor multifunction GPIO with 3.3V logic levels.
69	COM-GPIO	UART3-TXD	GPIO_AD_B1_06	UART3 TxD inputor multifunction GPIO with 3.3V logic levels.
70	Power	GND	-	-
71	Power	GND	-	-
72	COM-GPIO	UART2-CTS	GPIO_AD_B1_00	UART2 CTS outputor multifunction GPIO with 3.3V logic levels.
73	COM-GPIO	UART3-RXD	GPIO_AD_B1_07	UART3 RxD inputor multifunction GPIO with 3.3V logic levels.
74	COM-GPIO	UART1-RTS	GPIO_AD_B0_15	UART1 RTS inputor multifunction GPIO with 3.3V logic levels.
75	NC	-	-	Not internally connected.
76	COM-GPIO	UART3-CTS	GPIO_AD_B1_04	UART3 CTS outputor multifunction GPIO with 3.3V logic levels.
77	NC	-	-	Not internally connected.
78	COM-GPIO	UART2-RTS	GPIO_AD_B1_01	UART2 RTS inputor multifunction GPIO with 3.3V logic levels.
79	COM-GPIO	UART5-TXD	GPIO_B1_12	UART5 TxD outputor multifunction GPIO with 3.3V logic levels.
80	COM-GPIO	UART3-RTS	GPIO_AD_B1_05	UART3 RTS inputor multifunction GPIO with 3.3V logic levels.
81	Power	GND	-	-
82	Power	GND	-	-
83	NC	-	-	Not internally connected.
84	Power	GND	-	-
85	Power	+3.3VOUT	-	+3.3V generated by SOM's LDO.
86	NC	-	-	Not internally connected.
87	Power	+3.3VOUT	-	+3.3V generated by SOM's LDO.
88	Power	+3.3VOUT	-	+3.3V generated by SOM's LDO.
89	Power	+3.3VOUT	-	+3.3V generated by SOM's LDO.
90	Power	+3.3VOUT	-	+3.3V generated by SOM's LDO.
91	Power	+3.3VOUT	-	+3.3V generated by SOM's LDO.
92	Power	+3.3VOUT	-	+3.3V generated by SOM's LDO.
93	Power	+3.3VOUT	-	+3.3V generated by SOM's LDO.
94	NC	-	-	Not internally connected.
95	NC	-	-	Not internally connected.
96	Power	+5VIN	-	+4.0-5.5V input power supply.
97	Ethernet	ENET1-RXD0	GPIO_B1_04	Ethernet MAC1-PHY interface signal or multifunction GPIO with 3.3V logic levels.

98	Power	+5VIN	-	+4.0-5.5V input power supply.
99	Ethernet	ENET1-RXD1	GPIO_B1_05	Ethernet MAC1-PHY interface signal or multifunction GPIO with 3.3V logic levels.
100	Power	+5VIN	-	+4.0-5.5V input power supply.
101	Ethernet	ENET1-CRS-DV	GPIO_B1_06	Ethernet MAC1-PHY interface signal or multifunction GPIO with 3.3V logic levels.
102	Power	+5VIN	-	+4.0-5.5V input power supply.
103	Power	GND	-	-
104	Power	+5VIN	-	+4.0-5.5V input power supply.
105	NC	-	-	Not internally connected.
106	Power	+5VIN	-	+4.0-5.5V input power supply.
107	Power	GND	-	-
108	Power	+5VIN	-	+4.0-5.5V input power supply.
109	NC	-	-	Not internally connected.
110	Power	+5VIN	-	+4.0-5.5V input power supply.
111	Ethernet	ENET2-RXD0	GPIO_AD_B1_14	Ethernet MAC2-PHY interface signal or multifunction GPIO with 3.3V logic levels.
112	Power	+5VIN	-	+4.0-5.5V input power supply.
113	NC	-	-	Not internally connected.
114	Ethernet	ENET1-TXEN	GPIO_B1_09	Ethernet MAC1-PHY interface signal or multifunction GPIO with 3.3V logic levels.
115	Power	GND	-	-
116	Power	GND	-	-
117	Ethernet	ENET2-CRS-DV	GPIO_AD_B1_15	Ethernet MAC2-PHY interface signal or multifunction GPIO with 3.3V logic levels.
118	Ethernet	ENET1-TX-CLK	GPIO_B1_10	Ethernet MAC1-PHY interface signal or multifunction GPIO with 3.3V logic levels. In series is connected 10R resistor.
119	Ethernet	ENET2-TXD1	GPIO_AD_B1_13	Ethernet MAC2-PHY interface signal or multifunction GPIO with 3.3V logic levels.
120	Power	GND	-	-
121	Ethernet	ENET2-TXEN	GPIO_AD_B1_12	Ethernet MAC2-PHY interface signal or multifunction GPIO with 3.3V logic levels.
122	Ethernet	ENET1-TXD0	GPIO_B1_07	Ethernet MAC1-PHY interface signal or multifunction GPIO with 3.3V logic levels.
123	Ethernet	ENET2-TXD0	GPIO_B1_15	Ethernet MAC2-PHY interface signal or multifunction GPIO with 3.3V logic levels.
124	Ethernet	ENET1-TXD1	GPIO_B1_08	Ethernet MAC1-PHY interface signal or multifunction GPIO with 3.3V logic levels.
125	Power	GND	-	-
126	Ethernet	ENET1-RXER	GPIO_B1_11	Ethernet MAC1-PHY interface signal or multifunction GPIO with 3.3V logic levels.
127	Power	GND	-	-
128	Power	GND	-	-
129	LCD	LCD-DATA21	GPIO_B1_01	LCD interface signal or multifunction GPIO with 3.3V logic levels.
130	Power	GND	-	-
131	LCD	LCD-DATA22	GPIO_B1_02	LCD interface signal or multifunction GPIO with 3.3V logic levels.
132	Power	GND	-	-

133	LCD	LCD-DATA17	GND	Internally connected to GND.
134	LCD	LCD-DATA23	GPIO_B1_03	LCD interface signal or multifunction GPIO with 3.3V logic levels.
135	Power	GND	-	-
136	Power	GND	-	-
137	LCD	LCD_DATA18	GND	Internally connected to GND.
138	LCD	LCD-DATA19	GPIO_B0_15	LCD interface signal or multifunction GPIO with 3.3V logic levels. By default this pin is pulled-down with 10k resistor.
139	LCD	LCD-DATA13	GPIO_B0_12	LCD interface signal or multifunction GPIO with 3.3V logic levels. By default this pin is pulled-down with 10k resistor.
140	LCD	LCD-DATA20	GPIO_B1_00	LCD interface signal or multifunction GPIO with 3.3V logic levels.
141	LCD	LCD-DATA14	GPIO_B0_13	LCD interface signal or multifunction GPIO with 3.3V logic levels. By default this pin is pulled-down with 10k resistor.
142	LCD	LCD-DATA15	GPIO_B0_14	LCD interface signal or multifunction GPIO with 3.3V logic levels. By default this pin is pulled-down with 10k resistor.
143	LCD	LCD_DATA8	GND	Internally connected to GND.
144	LCD	LCD-DATA16	GND	Internally connected to GND.
145	LCD	LCD-DATA9	GND	Internally connected to GND.
146	Power	GND	-	-
147	Power	GND	-	-
148	LCD	LCD-DATA11	GPIO_B0_10	LCD interface signal or multifunction GPIO with 3.3V logic levels. By default this pin is pulled-down with 10k resistor.
149	LCD	LCD-DATA5	GPIO_B0_06	LCD interface signal or multifunction GPIO with 3.3V logic levels. By default this pin is pulled-down with 10k resistor.
150	LCD	LCD-DATA12	GPIO_B0_11	LCD interface signal or multifunction GPIO with 3.3V logic levels. By default this pin is pulled-down with 10k resistor.
151	LCD	LCD-DATA6	GPIO_B0_07	LCD interface signal or multifunction GPIO with 3.3V logic levels. By default this pin is pulled-down with 10k resistor.
152	LCD	LCD-DATA10	GPIO_B0_09	LCD interface signal or multifunction GPIO with 3.3V logic levels. By default this pin is pulled-down with 10k resistor.
153	LCD	LCD-DATA0	GND	Internally connected to GND.
154	LCD	LCD-DATA3	GPIO_B0_04	LCD interface signal or multifunction GPIO with 3.3V logic levels. By default this pin is pulled-down with 10k resistor.
155	LCD	LCD-DATA1	GND	Internally connected to GND.
156	Power	GND	-	-
157	LCD	LCD-RESET	GPIO_AD_B1_08	LCD interface signal or multifunction GPIO with 3.3V logic levels.
158	LCD	LCD-DATA4	GPIO_B0_05	LCD interface signal or multifunction GPIO with 3.3V logic levels. By default this pin is pulled-down with 10k resistor.
159	Power	GND	-	-

160	LCD	LCD-HSYNC	GPIO_B0_02	LCD interface signal or multifunction GPIO with 3.3V logic levels.
161	LCD	LCD-CLK	GPIO_B0_00	LCD interface signal or multifunction GPIO with 3.3V logic levels.
162	LCD	LCD-VSYNC	GPIO_B0_03	LCD interface signal or multifunction GPIO with 3.3V logic levels.
163	LCD	LCD-ENABLE	GPIO_B0_01	LCD interface signal or multifunction GPIO with 3.3V logic levels.
164	LCD	LCD-DATA2	GND	Internally connected to GND.
165	Power	GND	-	-
166	LCD	LCD-DATA7	GPIO_B0_08	LCD interface signal or multifunction GPIO with 3.3V logic levels. By default this pin is pulled-down with 10k resistor.
167	SDIO	SDIO1-D0	GPIO_SD_B0_02	SDIO interface signal or multifunction GPIO with 3.3V logic levels.
168	NC	-	-	Not internally connected.
169	SDIO	SDIO1-D3	GPIO_SD_B0_05	SDIO interface signal or multifunction GPIO with 3.3V logic levels.
170	NC	-	-	Not internally connected.
171	SDIO	SDIO1-D1	GPIO_SD_B0_03	SDIO interface signal or multifunction GPIO with 3.3V logic levels.
172	NC	-	-	Not internally connected.
173	SDIO	SDIO1-CMD	GPIO_SD_B0_00	SDIO interface signal or multifunction GPIO with 3.3V logic levels.
174	NC	-	-	Not internally connected.
175	SDIO	SDIO1-D2	GPIO_SD_B0_04	SDIO interface signal or multifunction GPIO with 3.3V logic levels.
176	NC	-	-	Not internally connected.
177	Power	GND	-	-
178	NC	-	-	Not internally connected.
179	SDIO	SDIO1-CLK	GPIO_SD_B0_01	SDIO interface signal or multifunction GPIO with 3.3V logic levels.
180	NC	-	-	Not internally connected.
181	Power	GND	-	-
182	NC	-	-	Not internally connected.
183	NC	-	-	Not internally connected.
184	Power	GND	-	-
185	Power	GND	-	-
186	NC	-	-	Not internally connected.
187	NC	-	-	Not internally connected.
188	NC	-	-	Not internally connected.
189	Power	GND	-	-
190	NC	-	-	Not internally connected.
191	NC	-	-	Not internally connected.
192	NC	-	-	Not internally connected.
193	NC	-	-	Not internally connected.
194	NC	-	-	Not internally connected.
195	NC	-	-	Not internally connected.
196	NC	-	-	Not internally connected.

197	NC	-	-	Not internally connected.
198	NC	-	-	Not internally connected.
199	Power	GND	-	-
200	Power	GND	-	-

Dimensions

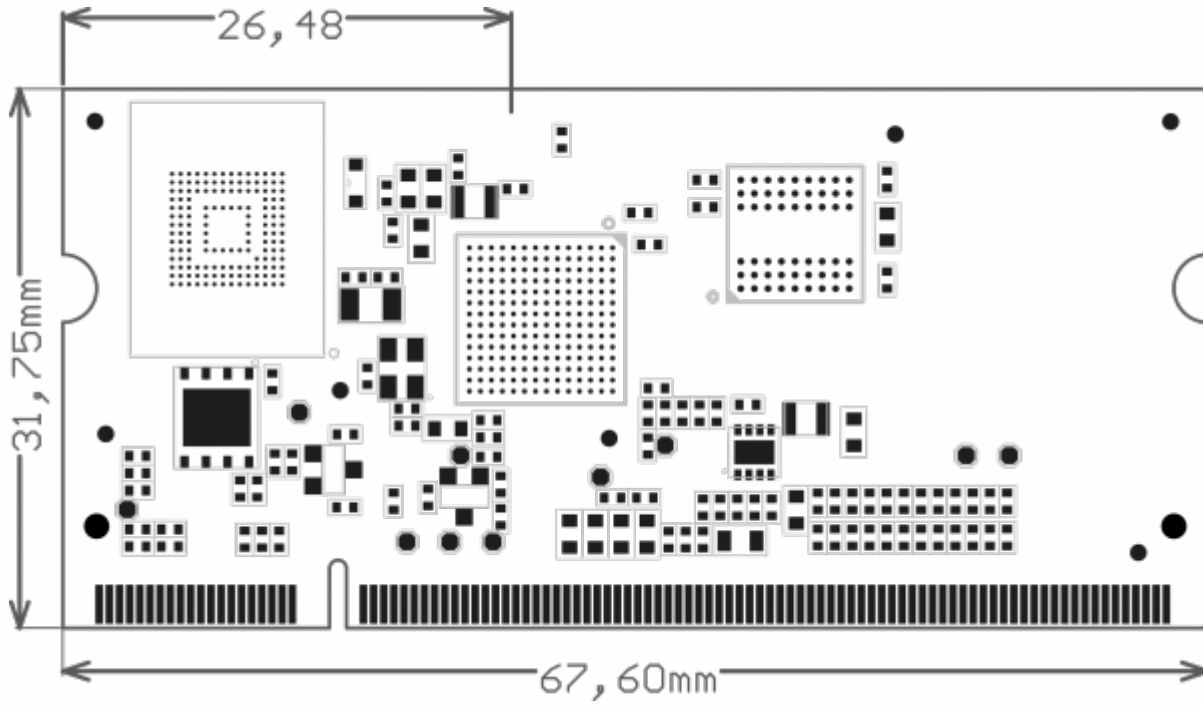



SoMLabs

Lwowska 5
05-120 Legionowo
Poland
Tel. +48 22 767 36 20
Email: contact@somlabs.com
<http://somlabs.com>

Disclaimer: The information in this document is provided in connection with SoMLabs products. No license, express or implied, to any intellectual property right is granted by this document or in connection with the sale of SoMLabs products. SoMLabs makes no representations or warranties with respect to the accuracy or completeness of the contents of this document and reserves the right to make changes to specifications and products descriptions at any time without notice. SoMLabs does not make any commitment to update the information contained herein.



Стандарт Электрон Связь

Мы молодая и активно развивающаяся компания в области поставок электронных компонентов. Мы поставляем электронные компоненты отечественного и импортного производства напрямую от производителей и с крупнейших складов мира.

Благодаря сотрудничеству с мировыми поставщиками мы осуществляем комплексные и плановые поставки широчайшего спектра электронных компонентов.

Собственная эффективная логистика и склад в обеспечивает надежную поставку продукции в точно указанные сроки по всей России.

Мы осуществляем техническую поддержку нашим клиентам и предпродажную проверку качества продукции. На все поставляемые продукты мы предоставляем гарантию .

Осуществляем поставки продукции под контролем ВП МО РФ на предприятия военно-промышленного комплекса России , а также работаем в рамках 275 ФЗ с открытием отдельных счетов в уполномоченном банке. Система менеджмента качества компании соответствует требованиям ГОСТ ISO 9001.

Минимальные сроки поставки, гибкие цены, неограниченный ассортимент и индивидуальный подход к клиентам являются основой для выстраивания долгосрочного и эффективного сотрудничества с предприятиями радиоэлектронной промышленности, предприятиями ВПК и научно-исследовательскими институтами России.

С нами вы становитесь еще успешнее!

Наши контакты:

Телефон: +7 812 627 14 35

Электронная почта: sales@st-electron.ru

Адрес: 198099, Санкт-Петербург,
Промышленная ул, дом № 19, литера Н,
помещение 100-Н Офис 331