



MICROCHIP

**Analog Solutions for Automotive Applications
Design Guide**

*This design guide includes analog solutions for Motor Control,
Power Supply, LED, Signal Chain and Sensor Applications*



Analog Competency

The demand for automobile electronics has never been greater. Do you need lower quiescent currents? Does your design require reduced board space? Designers of electronic control modules within the automobile are being challenged to deliver increased performance in a variety of systems including: powertrain, chassis, comfort, driver information, entertainment and safety. Microchip's broad portfolio of low-power analog products enable the development of cost-effective solutions that address these challenges and others facing the system designer.

Being one of the first companies to apply Non-Volatile Memory (NVM) technology to the development process for analog products, Microchip has utilized its NVM experience to deliver innovative analog solutions with unchallenged electrical characteristics.

Leveraging experience from the integration of analog features on PIC® microcontrollers, nanoWatt technology and low pin count packages, Microchip's analog circuitry consists of more than 400 different power management, linear, mixed signal, thermal management and interface products. As an innovative, market leading supplier of low-power solutions, Microchip Technology continues to expand its analog product portfolio to support the demanding needs of the automotive designer.

Analog and Interface Product Attributes

Low Power/Low Voltage

- Op Amp family with the lowest power for a given gain bandwidth
- 600 nA/1.4V/10 kHz bandwidth Op Amps
- 1.5V and 1.8V charge pumps and comparators
- Lowest power 12-bit ADC in a SOT-23 package

Integration

- One of the first to market integrated LDOs with Reset, fan controllers with temperature sensors and switcher regulators with LDOs and power good
- PGA integrates MUX, resistive ladder, gain switches, high-performance amplifier, SPI interface

Space Savings

- Resets, comparators, op amps, temperature sensors and LDOs in a SC-70 package, ADCs in a 5-lead SOT-23 package

Accuracy

- Offset trimmed after packaging using Non-Volatile Memory

Analog Competency – From Analog MCUs to Analog and Interface Products

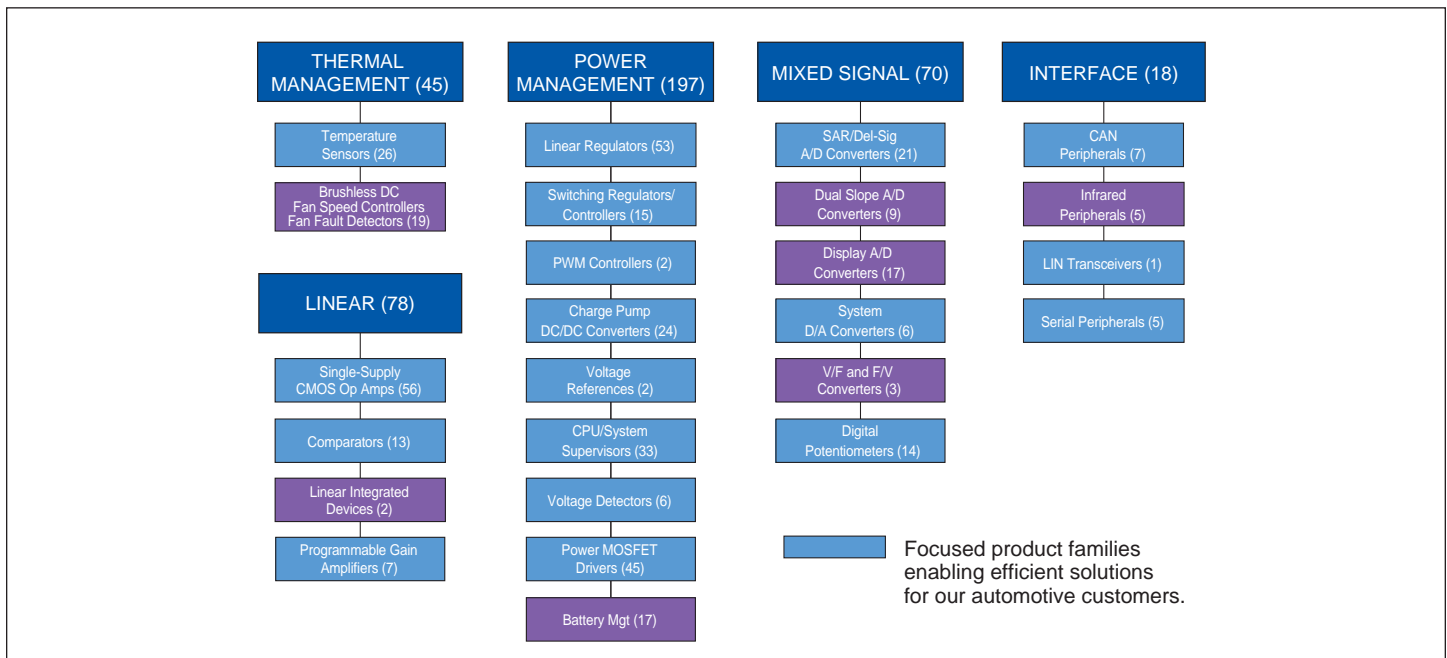

LOW-POWER ANALOG SOLUTIONS FOR AUTOMOTIVE APPLICATIONS

Microchip Analog Solutions Cover a Broad Range of Products and Applications in Automotive Systems

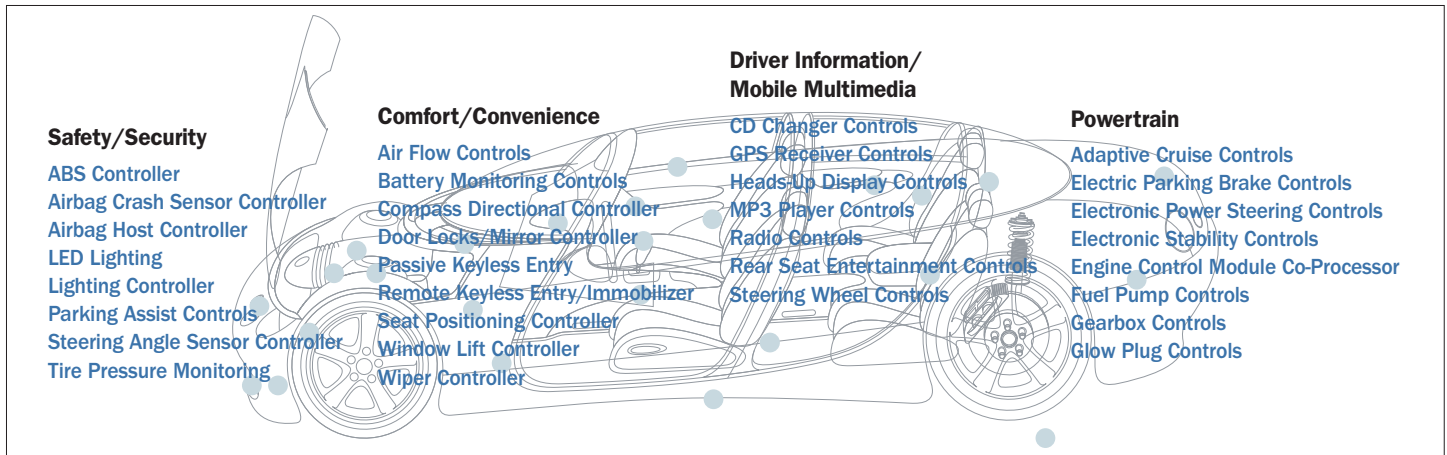

2002-2005 Analog Products FIT Rate Dynamic Life Test @ +150°C

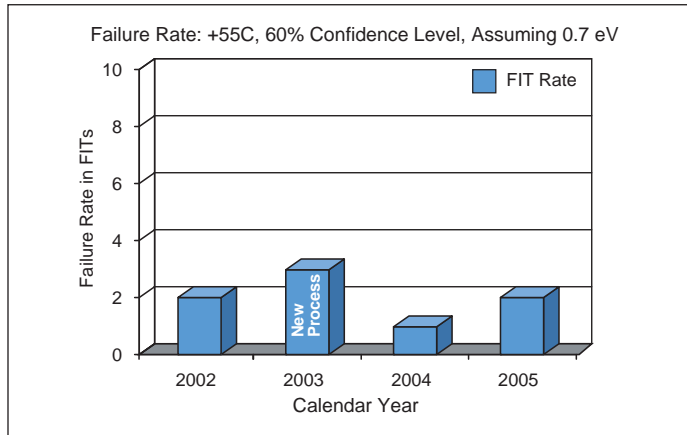

Stress Test Qualification

Microchip has experience with the automotive industry's quality requirements. Our automotive customers may request incremental device qualification testing such as the AEC-Q100, shown below.

AEC-Q100 Device Qualification Plan*

Test Name	Conditions
ELFR	150°C for 24 hours; Electrical test pre- and post-stress at +25°C and +125°C.
HTOL/DLT	150°C for 408 hours; Electrical test pre- and post-stress at -40, +25 and +125°C. Readouts at 0, 96 and 408 hours.
EDR Endurance Cycling	Specified erase/write cycles at +85°C; Electrical test pre- and post-stress at +25°C and 125°C.
EDR High-Temp Bake/Retention Bake	175°C for 504 hours; Electrical test pre- and post-stress at +25°C and +125°C. Readouts at 0, 96 and 504 hours.
EDR HTOL/DLT	150°C for 408 hours; Electrical test pre- and post-stress at -40, +25, and +125°C. Readouts at 0, 96 and 408 hours.
ESD - HBM	Electrical test pre- and post-stress at +25°C and +125°C. Test at each voltage: 500V, 1 KV, 2 KV, 4 KV.
ESD - MM	Electrical test pre- and post-stress at +25°C and +125°C. Test at each voltage: 100V, 200V, 300V, 400V.
Latch-Up (Overvoltage)	Test to ±14V and ±200 mA at +25°C and ±14V and ±100 mA at +125°C. Electrical test pre- and post-stress at +25°C and +125°C.

*Additional package level qualification is performed per AEC-Q100 recommendation.

Quality to Serve the Automotive Market

Our manufacturing meets the demanding quality and logistics requirements imposed by the automotive market environment. In 2003, Microchip became one of the first semiconductor manufacturers to achieve **ISO/TS-16949** certification.

Microchip Technology Automotive Certification History

Tempe, AZ – Fab

ISO 9001 Registered (1996)
ISO/TS 16949 Registration (2003)
Recertification (2006)

Gresham, OR – Fab

ISO/TS 16949 Registration (2004)
Recertification (2006)

Bangkok, Thailand – Assembly & Test

ISO 9002 Registered (1997)
ISO/TS 16949 Registration (2003)
Recertification (2006)
ISO 14001 (2004)

Solutions for Low-Frequency Communications Applications

Low-frequency communication systems provide many benefits in and around the vehicle. In sensing applications, it allows for the distribution of remote sensors while eliminating the concern for wired connection between the sensor and control module. In other applications, a transponder becomes a mobile device that can remain with the driver, or is attached to another apparatus that can be transferred to/from the vehicle when needed.

Application Examples

- Remote Keyless Entry (RKE)
- Passive Keyless Entry (PKE)
- Tire Pressure Monitoring Systems (TPMS)
- Child Seat Detection
- Immobilizers

Example of Passive Keyless Entry (PKE) Systems

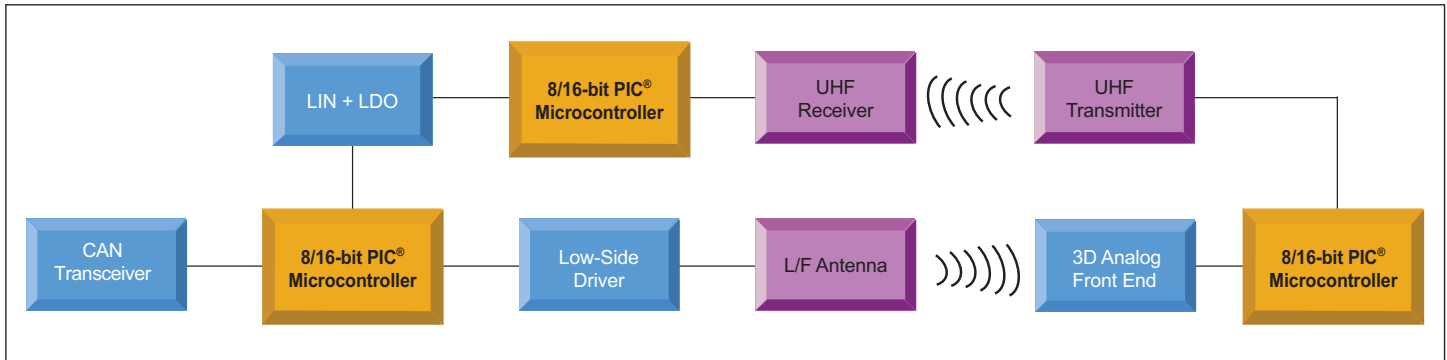

Recommended Product Families for PKE Applications

Family	Features	Device Examples
3D Analog Front End	Bidirectional low-frequency communications, low-operating and standby currents, programmable antenna tuning capacitance	MCP2030
CAN/LIN Products	CAN transceivers and stand-alone controllers with SPI, LIN transceivers with integrated voltage regulators	MCP2515, MCP2551X, MCP201
Op Amps	Single, dual and quad op amps, low quiescent current (600 nA), lowest Iq for a given Gain Bandwidth Product (GBWP); offered in space-saving packages	MCP6041/2/3/4, MCP6141/2/3/4 MCP601/2/3/4/6/7/8/9, MCP6021/2/3/4
Low-Side Drivers	Single, dual and quad MOSFET Drivers, 0.5 to 12A peak output currents, inverting and non-inverting outputs	TC4420/1/2/3/4/5/6/7/8/9/A, TC1410/1/2/3, TC4451/2, TC4467/8/9
Microcontrollers	Wide range of 8/16- RISC-based microcontrollers and digital signal controllers	PIC12, PIC16, PIC18, PIC24

Development Tools

Part Number	Product
DV251001	MCP2510/2515 CAN Developer's Kit
APGRD001	Passive Keyless Entry Reference Design
APGAC011	Accessory Key Fob For APGRD001 PKE Reference Design
DM163007/11/15	PICDEM™ CAN-LIN 1 2 and 3 Demonstration Boards
DM163005	PICDEM™ LIN Demonstration Board

LOW-POWER ANALOG SOLUTIONS FOR AUTOMOTIVE APPLICATIONS

Solutions for Motor Control

A broad product portfolio provides a complete system solution for your stepper motor, brushed DC motor, AC induction motor, variable speed brushless DC motor and switched reluctance motor applications.

Application Examples

- Electro Hydraulic Power Steering
- Electric Power Steering
- Wiper Control
- Water Pump, Oil Pump, Fuel Pump
- Window Lift
- Sun Roof
- Air Flaps
- Interior and External Mirrors

Microchip Solutions for Motor Control

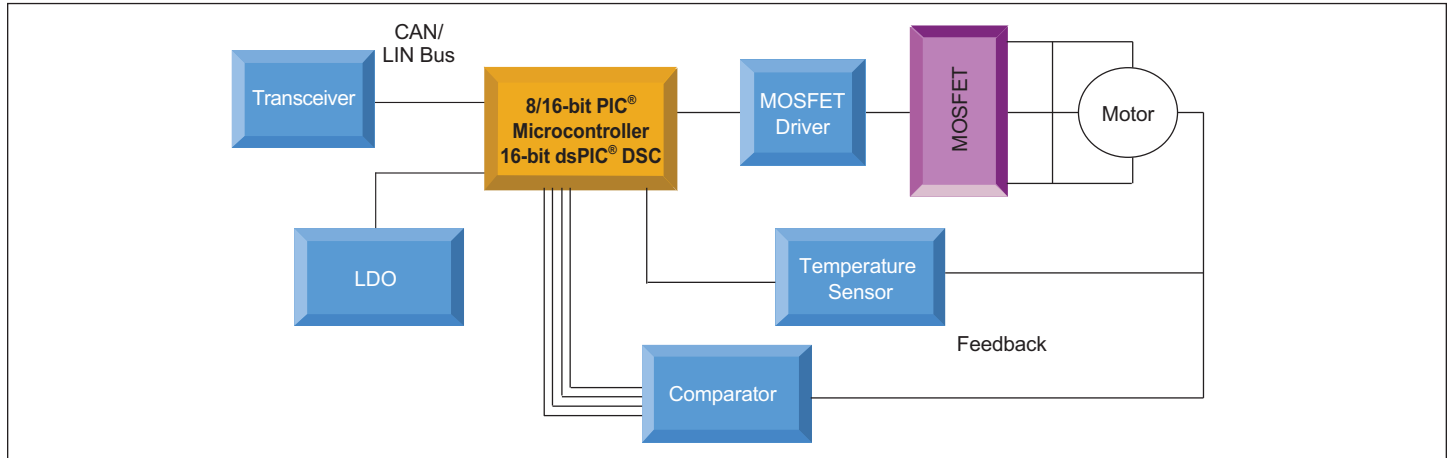

Recommended Product Families for Motor Control Applications

Family	Features	Device Examples
Temperature Sensors	Typical accuracy: $\pm 0.5^{\circ}\text{C}$, $\pm 1.0^{\circ}\text{C}$; Output options: 1) logic outputs, 2) voltage outputs, 3) serial outputs: SMBus/I ² C™, SPI	TC6501/2/3/4, MCP9700/1/A, MCP9800/1/2/3/5, TC72/4/5/7
Comparators	Single, dual and quad comparators, low-power consumption, low quiescent current, small packages	TC1027, TC1037/8/9, MCP6541/2/3/4/6/7/8/9
MOSFET Drivers	Single, dual and quad MOSFET Drivers, 0.5 to 12A peak output currents, inverting and non-inverting outputs	TC4420/1/2/3/4/5/6/7/8/9/A, TC1410/1/2/3, TC4451/2, TC4467/8/9
Low-Dropout Regulators	Low-operating current for longer battery life, very low-dropout voltage, high-output voltage accuracy: $\pm 0.4\%$ (typ), overcurrent and overtemperature protection, requires only 1 μF ceramic output capacitance	MCP1700/1/2
Transceivers	CAN transceivers and stand-alone controllers with SPI; LIN transceivers with integrated voltage regulators	MCP2515, MCP2551X, MCP201
Microcontrollers	Wide range of 8/16- RISC-based microcontrollers and digital signal controllers	PIC12, PIC16, PIC18, PIC24, dsPIC30, dsPIC33

Development Tools

Part Number	Product
Free at www.microchip.com	Motor Control Graphical User Interface
Free at www.microchip.com	FilterLab® Active Filter Design Software
DM183011	PICDEM™ MC Development Board
DM300020	dsPICDEM™ MC1 Motor Control Development Board
AC300020 (requires DM300020)	3-phase BLDC Low Voltage Motor (24V)
APGRD002	Window Lift Reference Design
MCP9700DM-PCTL	MCP9700 Temperature-to-Voltage Converter PICtail™ Demonstration Board
MCP9800DM-DL	MCP9800 Temperature Data Logger Demonstration Board
MCP9800DM-PCTL	MCP9800 Temperature Sensor PICtail™ Demonstration Board

Solutions for Power Supply Applications

The growing deployment of navigation, entertainment and communication equipment in modern cars, as well as the utilization of most advanced semiconductor technologies, has been changing the needs for voltage regulation in the car. Automotive power supplies are used for DC-DC conversion, DC voltage monitoring, pulse-width modulation and digital control. Electronic Control Units are using SEPIC and Buck Converters with multiple level output voltages and different current ratings.

Application Examples

- Car Radio
- Navigation System
- Car Communication/Entertainment Center
- GPS

Example of Infotainment Power Supply Unit

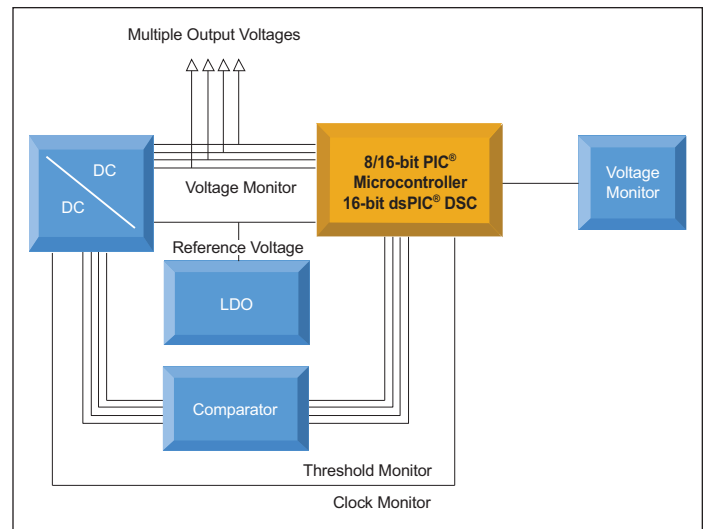

Recommended Product Families for Power Supply Applications

Family	Features	Device Examples
Comparators	Single, dual and quad comparators, low-power consumption, low quiescent current, small packages	TC1027, TC1037/8/9, MCP6541/2/3/4
Voltage Monitors	Low cost, precision system voltage supervisors; brown-out protection; wide range of output types, reset trip points and package options; watchdog input option	MCP102/3, MCP121, MCP131, MCP1316/17/18/19/20/21/22
Pulse Width Modulator	High-speed microcontroller adaptable PWM; excellent current mode controller, fast response time, provides a very tight limit to the maximum switch current over a wide range of input voltages, low quiescent current	MCP1630
Low-Dropout Regulators	Low-operating current for longer battery life, very low-dropout voltage, high-output voltage accuracy: $\pm 0.4\%$ (typ), overcurrent and overtemperature protection, requires only 1 μF ceramic output capacitance	MCP1700/1/2
Switching Regulators	Step-up and step-down DC-DC converters with soft start, programmable voltage/current supply, point-of-load sequencing, intelligent temperature compensation, overvoltage and overcurrent handling	MCP1601, MCP1650/1/2/3, MCP1612, TC105, TC120/5/6
Microcontrollers	Wide range of 8/16- RISC-based microcontrollers and digital signal controllers	PIC12, PIC16, PIC18, PIC24, dsPIC30, dsPIC33

Development Tools

Part Number	Product
MCP1601EV	MCP1601 Buck Regulator Evaluation Board
MCP1612EV	MCP1612 Synchronous Buck Regulator Evaluation Board
MCP1630DM-DDBS1	MCP1630 Automotive Input Boost Converter Demonstration Board
MCP1630RD DDBK1	MCP1630 +12V Dual Output Buck Converter Reference Design
MCP1650EV	MCP1650 Boost Controller Evaluation Board
MCP1726EV	MCP1726 1A LDO Evaluation Board
TC1016/17EV	TC1016/17 LDO Linear Regulator Evaluation Board
TC1303BDM-DDBK1	TC1303B Buck Regulator LDO Demonstration Board

Solutions for LED Applications

Traditional incandescent lamps are increasingly being replaced by Light Emitting Diodes (LEDs). LEDs offer compelling advantages, including a high level of light efficiency, reliability, mechanical stability and long operating lifetime. Because LEDs must be operated at constant current, DC-DC converters with the capability of efficiently translating the operating voltage into the LED forward voltage are required. Further key elements of LED control circuits are overcurrent protection, over heating protection (temperature sensing) and efficient energy utilization.

Application Examples

- Dashboard Illumination
- Signal and Warning Lights
- Daytime Running Lights
- Interior Lighting
- Tail Light
- Head up Displays
- Infrared Cameras

A typical LED solution can be as simple as a battery and a resistor, but with more complex dimming, flashing and multi-color applications; and more rigorous requirements in terms of matching brightness and color, there is an increasing need to control and monitor the current in an LED application.

Multiple White LED Solutions

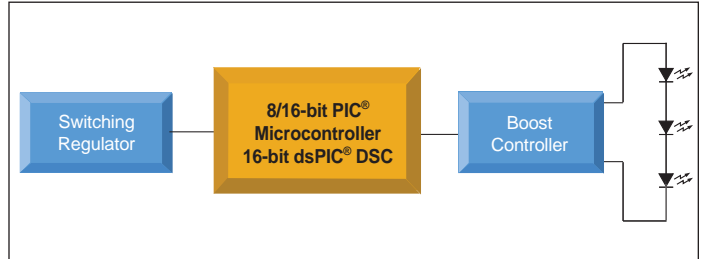

Recommended Product Families for LED Applications

Family	Features	Device Examples
Switching Regulators	Step-up and step-down DC-DC converters w/soft start, programmable voltage/current supply, point-of-load sequencing, intelligent temperature compensation, overvoltage and overcurrent handling	MCP1252/3, MCP1601, MCP1612, MCP1650/1/2/3, TC105, TC120/5/6
Pulse Width Modulator	High-speed microcontroller adaptable PWM; excellent current mode controller, fast response time, provides a very tight limit to the maximum switch current over a wide range of input voltages, low quiescent current	MCP1630
Temperature Sensors	Typical Accuracy: $\pm 0.5^{\circ}\text{C}$, $\pm 1.0^{\circ}\text{C}$; Output Options: 1) digital outputs, 2) analog outputs, 3) serial outputs: SMBus/I ² C™, SPI	TC6501/2/3/4, MCP9700/1/A, MCP9800/1/2/3/5, TC72/4/5/7
Op Amps	Single, dual and quad op amps, low quiescent current (600 nA), lowest I _q for a given Gain Bandwidth Product (GBWP); offered in space-saving packages	MCP6041/2/3/4, MCP6141/2/3/4, MCP601/2/3/4/6/7/8/9, MCP6021/2/3/4
Microcontrollers	Wide range of 8/16- RISC-based microcontrollers and digital signal controllers	PIC12, PIC16, PIC18, PIC24, dsPIC30, dsPIC33

Development Tools

Part Number	Product
DV164101	PICkit™ 1 Flash Starter Kit
AC163002	PICDEM™ MSC1 Infrared (IR) Driver Daughter Board
MCP1650DM-LED1	MCP1650 3W White LED Demonstration Board
MCP1650DM-LED2	MCP1650 Multiple White LED Demonstration Board
MCP6SX2DM-PCTLPD	MCP6SX2 PGA Photodiode PICTail™ Demonstration Board
MCP1252DM-BKLT	MCP1252 Charge Pump Backlight Demonstration Board

Solutions for Sensor Applications



Modern vehicles are networked PCs on wheels where sensors provide the interface to the real world. The number of sensors in automotive applications is rapidly increasing. Of all sensing technologies,

temperature sensing is the most common. Knowing and using the actual or relative temperature is critical. For instance, other sensors such as pressure, force, flow, level and position many times require temperature monitoring in order to ensure accuracy.

Signal Chain Solutions

Our extensive analog portfolio includes operational amplifiers and programmable gain amplifiers, voltage references, digital potentiometers, analog-to-digital converters and silicon IC temperature sensors to meet today's demanding measurement design requirements.

Application Examples

- Key-off Applications Requiring Low Power
- Humidity and Pressure Sensors
- Level and Tilt Sensors
- Air Quality Sensor
- Light and Temperature Sensor
- Rain Sensor
- ABS
- TPMS
- PKE/RKE
- Dashboard Illumination
- Car Audio (Infotainment)
- Air Bags (Occupant Detect)
- Electronic Power Steering
- Hybrid Electric Vehicle Battery Monitors
- Signal, Warning and Daytime Running Lights
- Approach, Crash and Steering Angle Sensors

Signal Chain Solutions

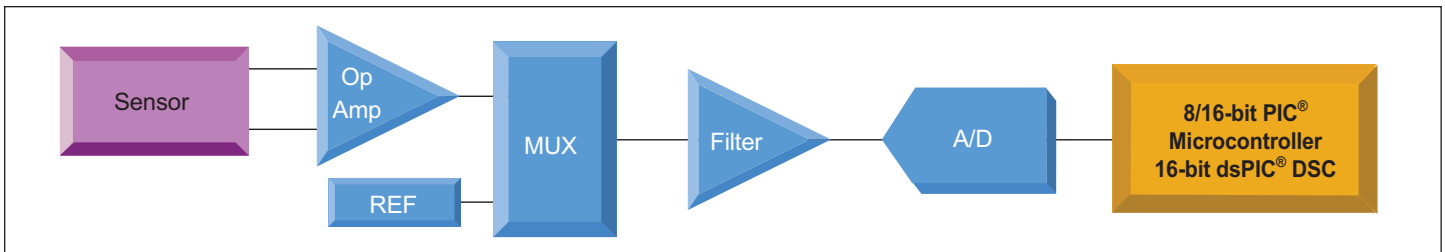

Recommended Product Families for Sensor Applications

Family	Features	Device Examples
Serial Output Temp Sensors	Offer excellent temperature accuracy with very low operating current; communication is accomplished via I ² C™ or SPI; all devices are offered in space-saving packages and feature very fast temperature conversion times	MCP9800/1/2/3/5, TC72/4/5/7/A
Voltage Output Temp Sensors	Temperature conversion accuracy, linear temperature slopes, small packages	MCP9700/1/A, TC1046/7/A
Logic Output Temp Sensors	Excellent temperature accuracy ($\pm 1^{\circ}\text{C}$ typical); low operating current (<600 μA); features include programmable hysteresis, remote temperature sensing and dual temperature limit output	TC620/1/2/3/4, TC6501/2/3/4, TCN75A
Programmable Gain Amplifiers (PGA)	Programmable over SPI bus, adds gain control and input channel selection to the embedded control system; reduces complexity of multiple sensor system to one amplifier; lower system costs, requires less space	MCP6S21/2/6/8, MCP6S91/2/3
Op Amps	Single, dual and quad op amps, low quiescent current (600 nA), lowest I _Q for a given Gain Bandwidth Product (GBWP); offered in space-saving packages	MCP6041/2/3/4, MCP6141/2/3/4, MCP601/2/3/4/6/7/8/9, MCP6021/2/3/4
Voltage References	Voltage references in SOT23-3 and T0-92 packages	MCP1525/41
Digital Potentiometers	A family of digital potentiometers combine high performance and low power consumption in a small package	MCP4011/2/3/4, MCP4021/2/3/4, MCP41010/050/100, MCP42010/050/100
Analog-to-Digital Converters (ADC)	Broad portfolio of high-precision SAR, Delta-Sigma and Dual Slope A/D Converters; SAR ADCs up to 13-bit with low power consumption combined in a small package	MCP3X01/2/4/8, MCP3X21, MCP3550/1/3, TC500/00A/10/14/20A/30/34, TC835/50, TC7135/14433/A
Microcontrollers	Wide range of 8/16- RISC-based microcontrollers and digital signal controllers	PIC12, PIC16, PIC18, PIC24, dsPIC30, dsPIC33

Development Tools for Sensor Applications

Part Number	Product
DV250501	MCP250XX CAN I/O Expander Developer's Kit
DV3201A	MCP3XXX Single/Dual ADC MXDEV® Daughter Board
DV3204A	MCP3204/08 MXDEV® Daughter Board
DV42XXX	MCP42XXX Digital Pot MXDEV® Daughter Board
DVMCPA	MXDEV Analog Evaluation System
MCP3221DM-PCTL	MCP3221 PICtail™ Demo Board
MCP3551DM-PCTL	MCP3551 Delta-Sigma ADC Demo Board
MCP355XDV-MS1	MCP355X Sensor Application Developer's Board
MCP402XEV	MCP402X Non-Volatile Digital Potentiometer Evaluation Board
MCP4XXDM-DB	MCP4XXX Digital Potentiometer Daughter Board
MCP6S22DM-PICTL	MCP6S22 PGA PICtail™ Demo Board
MCP6S2XEV	MCP6S2X PGA Evaluation Board
MCP6SX2DM-PCTLTH	MCP6SX2 PGA Thermistor PICtail™ Demo Board
MCP9700DM-PCTL	MCP9700 Temperature-to-Voltage Converter PICtail™ Demo Board
MCP9800DM-DL	MCP9800 Temperature Data Logger Demo Board
MCP9800DM-PCTL	MCP9800 Temperature Sensor PICtail™ Demo Board
TC72DM-PICTL	TC72 Digital Temperature Sensor PICtail™ Demo Board
TC74DEMO	TC74 Serial Digital Thermal Sensor Demo Board
TC77DM-PICTL	TC77 Thermal Sensor PICtail™ Demo Board
TC1047ADM-PICTL	TC1047A Temp-to-Voltage Converter PICtail™ Demo Board

Solutions for Connectivity Applications

Connectivity within the vehicle is dominated today by two main network protocols: CAN (Controller Area Network) and LIN (Local Interconnect Network). CAN utilizes a robust, high-speed protocol, usually linking major nodes or

subsystems within the vehicle, such as ABS, airbag, powertrain and suspension control modules. LIN is a low-speed, single-wire network that usually links nodes within a vehicle subsystem, such as body electronics, headlight controls and occupant detection.

Simple Sensor Node Using MCP2515 Standalone CAN Controller

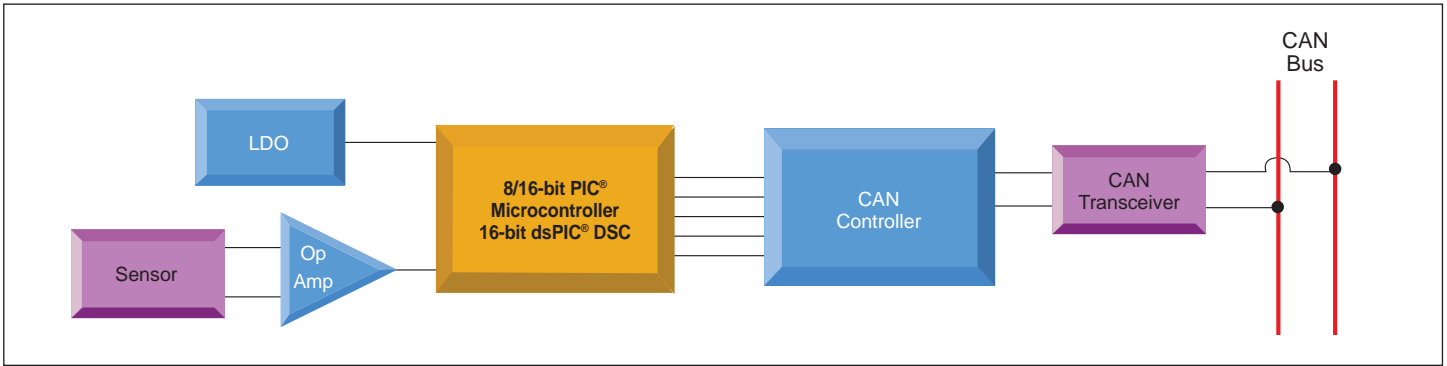

Motor Control Node Using MCP201 LIN Transceiver

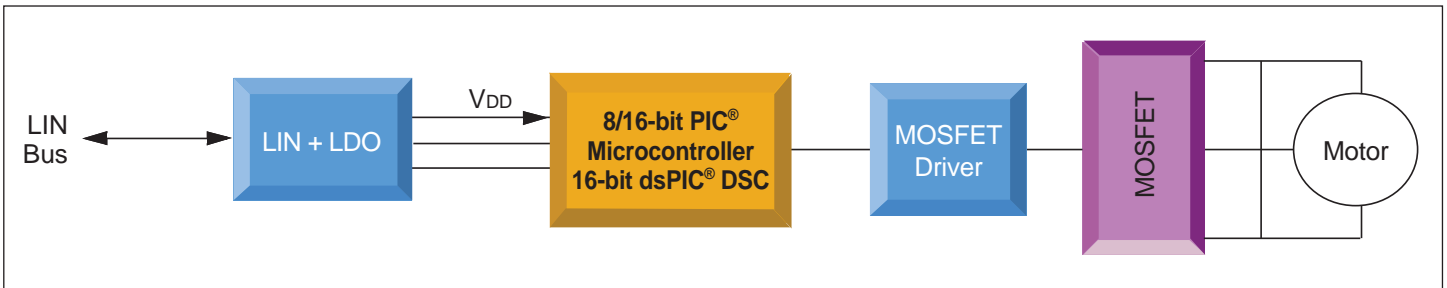

Recommended Interface Product Families for Connectivity Applications

Family	Features	Device Examples
CAN Controller	CAN V2.0B at 1Mb/s, two receive buffers, three transmit buffers high-speed SPI (10 MHz)	MCP2515
CAN Transceiver	Implements ISO 11898-2 physical layer requirements, $\pm 40V$ short-circuit protection, $\pm 250V$ transient protection	MCP2551X
CAN I/O Expander	CAN V2.0B, eight general purpose I/Os, four 10-bit A/D converters, two 10-bit PWM outputs	MCP25020/25/50/55
LIN Transceiver	Integrated LDO regulator ($5V \pm 5\%$), supports LIN rates up to 20 Kbaud, short-circuit and thermal overload protection	MCP201

Development Tools

Part Number	Product
DM163005	PICDEM™ LIN Demonstration Board
DM163007, DM163011, DM163015	PICDEM™ CAN-LIN 1, 2 and 3 Demonstration Boards
DV250501	MCP250XX CAN I/O Expander Developer's Kit
DV251001	MCP2510/2515 CAN Developer's Kit
MCP2515DM-PCTL	MCP2515 CAN Controller PICtail™ Demonstration Board
SOIC8EV	SOIC 8-Lead Evaluation Board

Application Notes and Additional Documentation Available

Application	Document Number	Title
Connectivity	AN228	A CAN Physical Layer Discussion
Connectivity	AN729	LIN Protocol Implementation Using PIC® MCUs
Connectivity	AN754	Understanding Microchip's CAN Module Bit Timing
Connectivity	AN816	A CAN System Using Multiple MCP25025 I/O Expanders
Low-Frequency Communications/PKE	AN232	Low-Frequency Magnetic Transmitter Design
Low-Frequency Communications/PKE	AN238	Tire Pressure Monitoring (TPM) System
Low-Frequency Communications/PKE	AN879	Using the Microchip Ultra Low-power Wake-up
Low-Frequency Communications/PKE	AN959	Using the PIC16F639 MCU for Smart Wireless
Low-Frequency Communications/PKE	AN1024	PKE System Design Using the PIC16F639
Low-Frequency Communications/PKE	TB090	MCP2030 Three-Channel Analog Front-End
Low-Frequency Communications/PKE	TB088	PIC16F639 Microcontroller Overview
Motor Control	AN799	Matching MOSFET Drivers to MOSFETs
Motor Control	AN894	Motor Control Sensor Feedback Circuits
Motor Control	AN898	Determining MOSFET Driver Needs for Motor Drive Applications
Motor Control	AN885	Brushless DC (BLDC) Motor Fundamentals
Motor Control	AN857	Brushless DC Motor Control Made Easy
Motor Control	AN763	Latch-Up Protection for MOSFET Drivers
Motor Control	AN807	Low-Cost DC Motor Speed Control with CMOS ICs
Power Supply	AN216	DC-DC Converter Controller using a PIC® Microcontroller
Power Supply	AN686	Understanding and Using Supervisory Circuits
Power Supply	AN761	LDO Thermal Considerations
Power Supply	AN765	Using Microchip's Micropower LDOs
Power Supply	AN766	Pin-compatible CMOS Upgrades to Bipolar LDOs
Power Supply	AN763	Latch-Up Protection for MOSFET Drivers
Power Supply	TB081	Soft-Start for Switching Power Supplies
Power Supply	TB085	A Simple Circuit for Driving Microcontroller Friendly PWM Generators
LED/Lighting	AN874	Buck Configuration High-Power LED Driver
LED/Lighting	AN948	Efficiently Powering Nine White LEDs with the MCP1650
LED/Lighting	TB029	Complementary LED Drive
LED/Lighting	TB060	Drive High Intensity White LEDs Efficiently Using the PIC16C781
LED/Lighting	TB062	High-Power IR LED Driver Using the PIC16C781/782
LED/Lighting	DS40040	PIC® Comparator Tips 'n Tricks
LED/Lighting	DS41215	8-pin Flash PIC® Microcontroller Tips 'n Tricks
Sensors/Signal Chain	AN251	Bridge Sensing with the MCP6S2X PGAs
Sensors/Signal Chain	AN679	Temperature Sensing Technologies
Sensors/Signal Chain	AN688	Layout Tips for 12-bit A/D Converter Application
Sensors/Signal Chain	AN691	Optimizing the Digital Potentiometer in Precision Circuits
Sensors/Signal Chain	AN695	Interfacing Pressure Sensors to Microchip's Analog Peripherals
Sensors/Signal Chain	AN699	Anti-Aliasing, Analog Filters for Data Acquisition Systems
Sensors/Signal Chain	AN845	Communicating with the MCP3221 using PIC Microcontrollers
Sensors/Signal Chain	AN865	Sensing Light with a Programmable Gain Amplifier
Sensors/Signal Chain	AN866	Temperature Sensing with a Programmable Gain Amplifier
Sensors/Signal Chain	AN981	Interfacing the MPC9700 Analog Output Temperature Sensor to a PIC® Microcontroller
Sensors/Signal Chain	AN988	Interfacing the MCP9800 I ² C™ Digital Temperature Sensor to a PIC® Microcontroller
Sensors/Signal Chain	TB051	Precision Temperature Measurement using a TC1046/TC1047 Sensor and a PIC16F872 Microcontroller

Support

Microchip is committed to supporting its customers in developing products faster and more efficiently. We maintain a worldwide network of field applications engineers and technical support ready to provide product and system assistance. In addition, the following service areas are available at www.microchip.com:

- **Support** link provides a way to get questions answered fast: <http://support.microchip.com>
- **Sample** link offers evaluation samples of any Microchip device: <http://sample.microchip.com>
- **Forum** link provides access to knowledge base and peer help: <http://forum.microchip.com>
- **Buy** link provides locations of Microchip Sales Channel Partners: www.microchip.com/sales

Sales Office Listing

AMERICAS

Atlanta

Tel: 678-957-9614

Boston

Tel: 774-760-0087

Chicago

Tel: 630-285-0071

Cleveland

Tel: 216-447-0464

Dallas

Tel: 972-818-7423

Detroit

Tel: 248-538-2250

Kokomo

Tel: 765-864-8360

Los Angeles

Tel: 949-462-9523

Santa Clara

Tel: 408-961-6444

Toronto

Mississauga, Ontario

Tel: 905-673-0699

EUROPE

Austria - Wels

Tel: 43-7242-2244-39

Denmark - Copenhagen

Tel: 45-4450-2828

France - Paris

Tel: 33-1-69-53-63-20

Germany - Munich

Tel: 49-89-627-144-0

Italy - Milan

Tel: 39-0331-742611

Netherlands - Druunen

Tel: 31-416-690399

Spain - Madrid

Tel: 34-91-708-08-90

UK - Wokingham

Tel: 44-118-921-5869

Training

If additional training interests you, then Microchip can help. We continue to expand our technical training options, offering a growing list of courses and in-depth curriculum locally, as well as significant online resources – whenever you want to use them.

- Regional Training Centers: www.microchip.com/rtc
- MASTERS Conferences: www.microchip.com/masters
- Worldwide Seminars: www.microchip.com/seminars
- eLearning: www.microchip.com/webseminars
- Resources from our Distribution and Third Party Partners www.microchip.com/training

ASIA/PACIFIC

Australia - Sydney

Tel: 61-2-9868-6733

China - Beijing

Tel: 86-10-8528-2100

China - Chengdu

Tel: 86-28-8665-5511

China - Hong Kong SAR

Tel: 852-2401-1200

China - Nanjing

Tel: 86-25-8473-2460

China - Qingdao

Tel: 86-532-8502-7355

China - Shanghai

Tel: 86-21-5407-5533

China - Shenyang

Tel: 86-24-2334-2829

China - Shenzhen

Tel: 86-755-8203-2660

China - Wuhan

Tel: 86-27-5980-5300

China - Xiamen

Tel: 86-592-2388138

China - Xian

Tel: 86-29-8833-7252

China - Zhuhai

Tel: 86-756-3210040

ASIA/PACIFIC

India - Bangalore

Tel: 91-80-3090-4444

India - New Delhi

Tel: 91-11-4160-8631

India - Pune

Tel: 91-20-2566-1512

Japan - Yokohama

Tel: 81-45-471- 6166

Korea - Daegu

Tel: 82-53-744-4301

Korea - Seoul

Tel: 82-2-554-7200

Malaysia - Kuala Lumpur

Tel: 60-3-6201-9857

Malaysia - Penang

Tel: 60-4-227-8870

Philippines - Manila

Tel: 63-2-634-9065

Singapore

Tel: 65-6334-8870

Taiwan - Hsin Chu

Tel: 886-3-572-9526

Taiwan - Kaohsiung

Tel: 886-7-536-4818

Taiwan - Taipei

Tel: 886-2-2500-6610

Thailand - Bangkok

Tel: 66-2-694-1351

1/26/09

Microcontrollers • Digital Signal Controllers • Analog • Serial EEPROMs

Information subject to change. The Microchip name and logo, the Microchip logo, dsPIC and PIC are registered trademarks of Microchip Technology Incorporated in the U.S.A. and other countries. FilterLab and MXDEV are registered trademarks of Microchip Technology Incorporated in the U.S.A. dsPICDEM, PICkit, PICDEM and PICtail are trademarks of Microchip Technology Incorporated in the U.S.A. and other countries. All other trademarks mentioned herein are property of their respective companies. © 2009, Microchip Technology Incorporated. All Rights Reserved. Printed in the U.S.A. 2/09 DS01005C



MICROCHIP
www.microchip.com

Microchip Technology Inc.
2355 W. Chandler Blvd.
Chandler, AZ 85224-6199



Стандарт Электрон Связь

Мы молодая и активно развивающаяся компания в области поставок электронных компонентов. Мы поставляем электронные компоненты отечественного и импортного производства напрямую от производителей и с крупнейших складов мира.

Благодаря сотрудничеству с мировыми поставщиками мы осуществляем комплексные и плановые поставки широчайшего спектра электронных компонентов.

Собственная эффективная логистика и склад в обеспечивает надежную поставку продукции в точно указанные сроки по всей России.

Мы осуществляем техническую поддержку нашим клиентам и предпродажную проверку качества продукции. На все поставляемые продукты мы предоставляем гарантию .

Осуществляем поставки продукции под контролем ВП МО РФ на предприятия военно-промышленного комплекса России , а также работаем в рамках 275 ФЗ с открытием отдельных счетов в уполномоченном банке. Система менеджмента качества компании соответствует требованиям ГОСТ ISO 9001.

Минимальные сроки поставки, гибкие цены, неограниченный ассортимент и индивидуальный подход к клиентам являются основой для выстраивания долгосрочного и эффективного сотрудничества с предприятиями радиоэлектронной промышленности, предприятиями ВПК и научно-исследовательскими институтами России.

С нами вы становитесь еще успешнее!

Наши контакты:

Телефон: +7 812 627 14 35

Электронная почта: sales@st-electron.ru

Адрес: 198099, Санкт-Петербург,
Промышленная ул, дом № 19, литера Н,
помещение 100-Н Офис 331