

# NHD-12232AZ-FL-YBW

## Graphic Liquid Crystal Display Module

NHD-	Newhaven Display
12232-	122 x 32 pixels
AZ-	Model
F-	Transflective
L-	Yellow/Green LED Backlight
Y-	STN- Yellow/Green
B-	6:00 view
W-	Wide Temperature (-20°C ~+70°C)
	<b>RoHS Compliant</b>

**Newhaven Display International, Inc.**

2511 Technology Drive, Suite 101

Elgin IL, 60124

Ph: 847-844-8795

Fax: 847-844-8796

[www.newhavendisplay.com](http://www.newhavendisplay.com)

[nhtech@newhavendisplay.com](mailto:nhtech@newhavendisplay.com)

[nhsales@newhavendisplay.com](mailto:nhsales@newhavendisplay.com)

## Document Revision History

Revision	Date	Description	Changed by
0	10/22/2008	Initial Release	-
1	3/16/2010	User guide reformat	BE
2	4/15/2010	Controller update	BE
3	5/5/2010	Block Diagram update	BE
4	8/5/2010	Electrical Characteristics Update	MP
5	10/25/2011	Electrical characteristics updated	AK
6	4/19/2012	Sample code updated	SB

## Functions and Features

- 122 x 32 pixels
- Built-in SBN1661G\_M02 Controller
- +5.0V power supply
- 1/32 duty cycle; 1/9 bias
- RoHS Compliant

# Mechanical Drawing

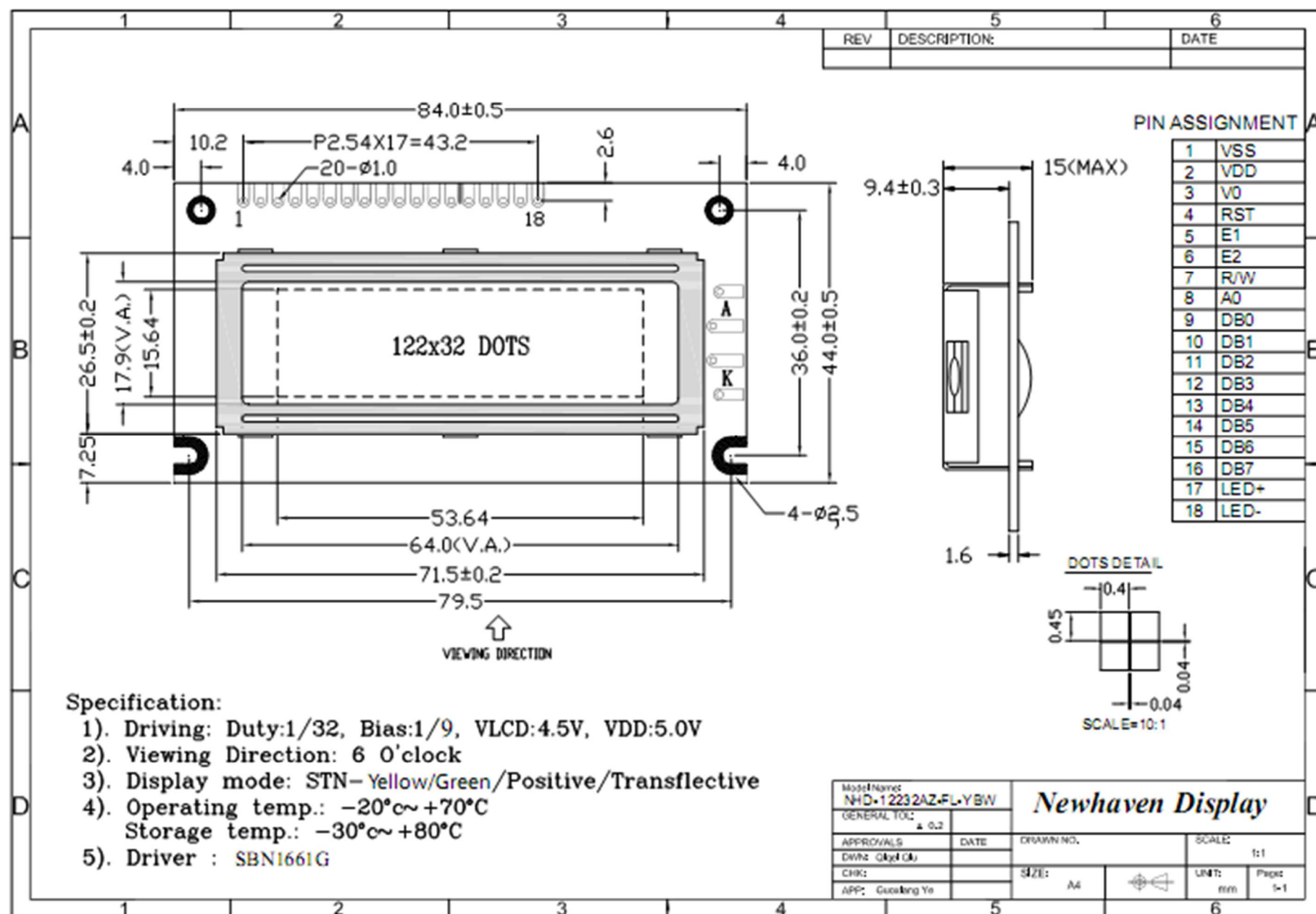

## Pin Description and Wiring Diagram

Pin No.	Symbol	External Connection	Function Description
1	VSS	Power Supply	Ground
2	VDD	Power Supply	Power supply for logic (+5.0V)
3	V0	Adj Power Supply	Power supply for contrast (approx. 0.5V)
4	RST	MPU	Active LOW Reset signal
5	E1	MPU	Operation enable signal. Falling edge triggered, SEG (1~60)
6	E2	MPU	Operation enable signal. Falling edge triggered, SEG (61~120)
7	R/W	MPU	Read/Write select signal, R/W=1: Read R/W: =0: Write
8	A0	MPU	Register select signal. A0=0: Command, A0=1: Data
9-16	DB0-DB7	MPU	This is an 8-bit bi-directional data bus
17	LED+	Power Supply	Power supply for LED Backlight (+5.0V via on-board resistor)
18	LED-	Power Supply	Ground for Backlight

Recommended LCD connector: 2.54mm pitch pins

Backlight connector: - Mates with: -

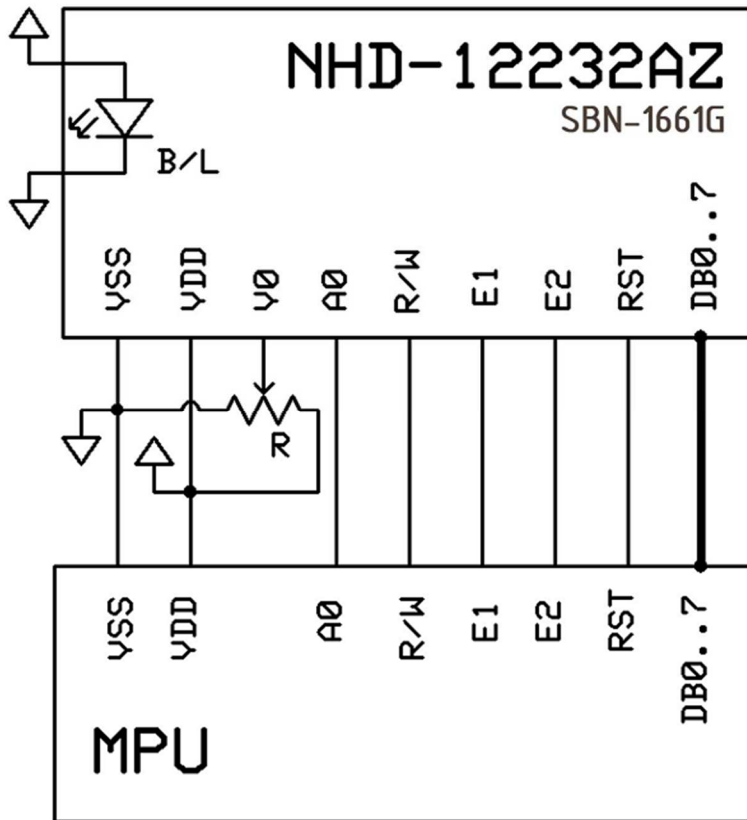

## Electrical Characteristics

Item	Symbol	Condition	Min.	Typ.	Max.	Unit
Operating Temperature Range	Top	Absolute Max	-20	-	+70	°C
Storage Temperature Range	Tst	Absolute Max	-30	-	+80	°C
Supply Voltage	VDD		4.7	5.0	5.5	V
Supply Current	IDD	Ta=25°C, VDD=5.0V	-	2.0	3.0	mA
Supply for LCD (contrast)	VDD-V0	Ta=25°C	-	4.5	-	V
"H" Level input	VIH		0.7*VDD	-	VDD	V
"L" Level input	VIL	-	0	-	1.1	V
"H" Level output	VOH	-	VDD-0.3	-	VDD	V
"L" Level output	VOL	-	0	-	0.3	V
Backlight Supply Voltage	VLED		-	5.0	-	V
Backlight Supply Current	ILED	VLED=5.0V	-	120	-	mA

## Optical Characteristics

Item	Symbol	Condition	Min.	Typ.	Max.	Unit
Viewing Angle - Vertical (top)	AV	Cr ≥ 3	-	10	-	
Viewing Angle – Vertical (bottom)	AV	Cr ≥ 3	-	60	-	°
Viewing Angle – Horizontal (left)	AH	Cr ≥ 3	-	45	-	
Viewing Angle - Horizontal (right)	AH	Cr ≥ 3	-	45	-	°
Contrast Ratio	Cr		-	5	-	-
Response Time (rise)	Tr	-	-	100	150	ms
Response Time (fall)	Tf	-	-	150	200	ms

## Controller Information

Built-in SBN1661G\_M02. Download specification at [http://www.newhavendisplay.com/app\\_notes/SBN1661G.pdf](http://www.newhavendisplay.com/app_notes/SBN1661G.pdf)

## Table of Commands

COMMAND	COMMAND CODE								FUNCTION
	D7	D6	D5	D4	D3	D2	D1	D0	
Write Display Data	Data to be written into the Display Data Memory.								Write a byte of data to the Display Data Memory.
Read Display Data	Data read from the Display Data Memory.								Read a byte of data from the Display Data Memory.
Read-Modify-Write	1	1	1	0	0	0	0	0	Start Read-Modify-Write operation.
END	1	1	1	0	1	1	1	0	Stop Read-Modify-Write operation.
Software Reset	1	1	1	0	0	0	1	0	Software Reset.

## Timing Characteristics

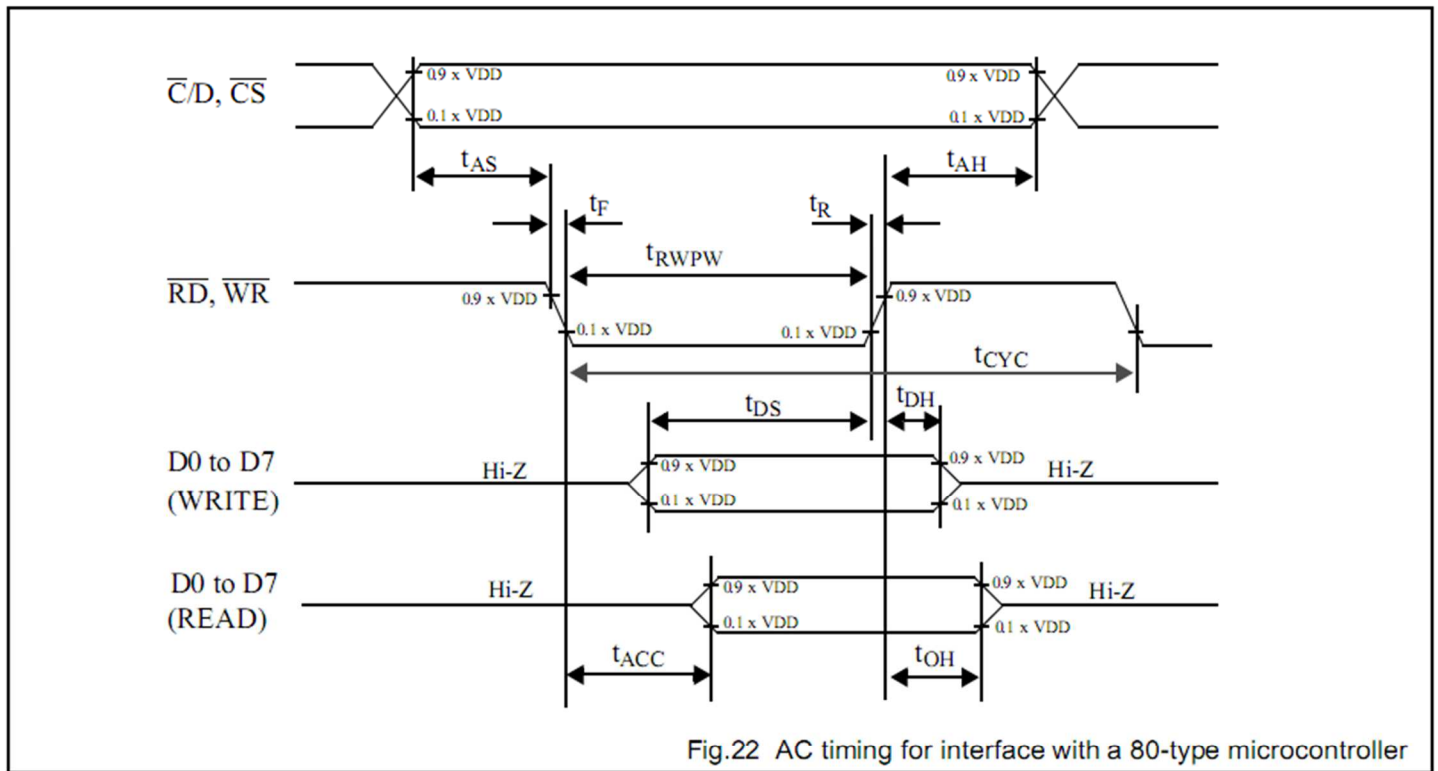
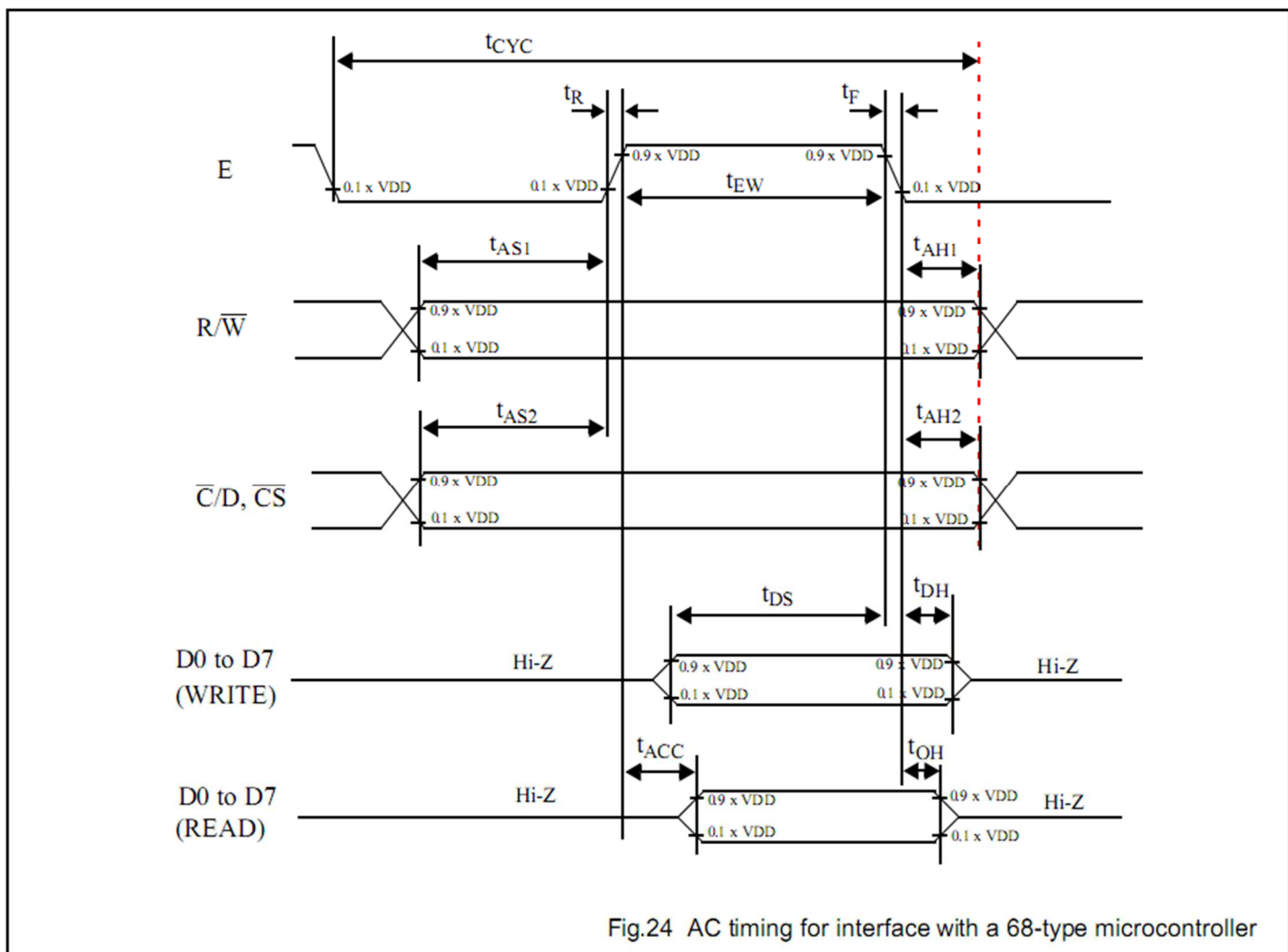

Fig.22 AC timing for interface with a 80-type microcontroller

$V_{DD} = 5 \text{ V} \pm 10\%$ ;  $V_{SS} = 0 \text{ V}$ ;  $T_{amb} = -20 \text{ }^\circ\text{C}$  to  $+75 \text{ }^\circ\text{C}$ .

symbol	parameter	min.	max.	test conditons	unit
$t_{AS}$	Address set-up time	20			ns
$t_{AH}$	Address hold time	10			ns
$t_F, t_R$	Read/Write pulse falling/rising time		15		ns
$t_{RWPW}$	Read/Write pulse width	200			ns
$t_{CYC}$	System cycle time	1000			ns
$t_{DS}$	Data setup time	80			ns
$t_{DH}$	Data hold time	10			ns
$t_{ACC}$	Data READ access time		90	CL= 100 pF.	ns
$t_{OH}$	Data READ output hold time	10	60	Refer to Fig. 23.	ns



$V_{DD} = 5 V \pm 10\%$ ;  $V_{SS} = 0 V$ ;  $T_{amb} = -20^{\circ}C$  to  $+75^{\circ}C$ .

symbol	parameter	min.	max.	test conditons	unit
$t_{AS1}$	Address set-up time with respect to $R/\bar{W}$	20			ns
$t_{AS2}$	Address set-up time with respect to $\bar{C}/D, \bar{CS}$	20			ns
$t_{AH1}$	Address hold time with respect to $R/\bar{W}$	10			ns
$t_{AH2}$	Address hold time respect with to $\bar{C}/D, \bar{CS}$	10			ns
$t_{F}, t_{R}$	Enable (E) pulse falling/rising time		15		ns
$t_{CYC}$	System cycle time	1000		Note 1	ns
$t_{EWR}$	Enable pulse width for READ	100			ns
$t_{EWW}$	Enable pulse width for WRITE	80			ns
$t_{DS}$	Data setup time	80			ns
$t_{DH}$	Data hold time	10			ns
$t_{ACC}$	Data access time		90	CL= 100 pF.	ns
$t_{OH}$	Data output hold time	10	60	Refer to Fig. 23.	ns

## Example Initialization Program:

```
/******  
void Comleft(char i)  
{  
    P1 = i;  
    R_W = 0;  
    D_I = 0;  
    E1 = 1;  
    delay(2);  
    E1 = 0;  
}  
  
void Comright(char i)  
{  
    P1 = i;  
    R_W = 0;  
    D_I = 0;  
    E2 = 1;  
    delay(2);  
    E2 = 0;  
}  
  
void Writeleft(char i)  
{  
    P1 = i;  
    R_W = 0;  
    D_I = 1;  
    E1 = 1;  
    delay(2);  
    E1 = 0;  
}  
  
void Writerright(char i)  
{  
    P1 = i;  
    R_W = 0;  
    D_I = 1;  
    E2 = 1;  
    delay(2);  
    E2 = 0;  
}  
/******  
void bothSides(char i)  
{  
    Comleft(i);  
    Comright(i);  
}  
/******  
  
void init()  
{  
    P1 = 0;  
    P3 = 0;  
    RST = 0;           //Reset RST  
    delay(1);  
    RST = 1;           //Reset RST= M68 Interface  
    delay(10);  
    D_I = 0;  
    R_W = 1;  
  
    bothSides(0xE2);   //0xE2 – Software reset  
    delay(10);  
    bothSides(0xA4);   //0xA4 – Static Driver off  
    bothSides(0xA9);   //0xA9 – select 1/32 duty  
    bothSides(0xA0);   //0xA0 – Memory/Segment mapping normal  
    bothSides(0xEE);   //0xEE – End  
    bothSides(0xC0);   //0xC0 – start at line address 0x00  
    bothSides(0xAF);   //0xAF – display on  
}  
/******
```



## Quality Information

Test Item	Content of Test	Test Condition	Note
High Temperature storage	Endurance test applying the high storage temperature for a long time.	+80°C , 200hrs	2
Low Temperature storage	Endurance test applying the low storage temperature for a long time.	-30°C , 200hrs	1,2
High Temperature Operation	Endurance test applying the electric stress (voltage & current) and the high thermal stress for a long time.	+70°C 200hrs	2
Low Temperature Operation	Endurance test applying the electric stress (voltage & current) and the low thermal stress for a long time.	-20°C , 200hrs	1,2
High Temperature / Humidity Operation	Endurance test applying the electric stress (voltage & current) and the high thermal with high humidity stress for a long time.	+60°C , 90% RH , 96hrs	1,2
Thermal Shock resistance	Endurance test applying the electric stress (voltage & current) during a cycle of low and high thermal stress.	-20°C,30min -> 25°C,5min -> 70°C,30min = 1 cycle 10 cycles	
Vibration test	Endurance test applying vibration to simulate transportation and use.	10-55Hz , 15mm amplitude. 60 sec in each of 3 directions X,Y,Z For 15 minutes	3
Static electricity test	Endurance test applying electric static discharge.	VS=800V, RS=1.5kΩ, CS=100pF One time	

**Note 1:** No condensation to be observed.

**Note 2:** Conducted after 4 hours of storage at 25°C, 0%RH.

**Note 3:** Test performed on product itself, not inside a container.

## Precautions for using LCDs/LCMs

See Precautions at [www.newhavendisplay.com/specs/precautions.pdf](http://www.newhavendisplay.com/specs/precautions.pdf)

## Warranty Information and Terms & Conditions

[http://www.newhavendisplay.com/index.php?main\\_page=terms](http://www.newhavendisplay.com/index.php?main_page=terms)



**Стандарт  
Электрон  
Связь**

Мы молодая и активно развивающаяся компания в области поставок электронных компонентов. Мы поставляем электронные компоненты отечественного и импортного производства напрямую от производителей и с крупнейших складов мира.

Благодаря сотрудничеству с мировыми поставщиками мы осуществляем комплексные и плановые поставки широчайшего спектра электронных компонентов.

Собственная эффективная логистика и склад в обеспечивает надежную поставку продукции в точно указанные сроки по всей России.

Мы осуществляем техническую поддержку нашим клиентам и предпродажную проверку качества продукции. На все поставляемые продукты мы предоставляем гарантию .

Осуществляем поставки продукции под контролем ВП МО РФ на предприятия военно-промышленного комплекса России , а также работаем в рамках 275 ФЗ с открытием отдельных счетов в уполномоченном банке. Система менеджмента качества компании соответствует требованиям ГОСТ ISO 9001.

Минимальные сроки поставки, гибкие цены, неограниченный ассортимент и индивидуальный подход к клиентам являются основой для выстраивания долгосрочного и эффективного сотрудничества с предприятиями радиоэлектронной промышленности, предприятиями ВПК и научно-исследовательскими институтами России.

С нами вы становитесь еще успешнее!

**Наши контакты:**

**Телефон:** +7 812 627 14 35

**Электронная почта:** [sales@st-electron.ru](mailto:sales@st-electron.ru)

**Адрес:** 198099, Санкт-Петербург,  
Промышленная ул, дом № 19, литера Н,  
помещение 100-Н Офис 331