

To Our Customers

CEL continues to offer industry leading semiconductor products from Japan. We are pleased to add new communication products from THine Electronics to our product portfolio.



THCV218

V-by-One® HS High-speed video data receiver

General Description

THCV218 is designed to support video data transmission between the host and display. One high-speed lane can carry up to 32bit data and 3 bits of synchronizing signals at a pixel clock frequency from 20MHz to 85MHz. This chip, which has two high-speed data lanes, can receive video data up to 1080p/10b/60Hz. The maximum serial data rate is 3.4Gbps/lane.

Width	Link	CMOS IO Frequency
24bit and 32bit	Si/So	20MHz to 85MHz
	Di/Do	
	Di/So	40MHz to 170MHz

Features

- Color depth selectable: 24(8*3)/32(10*3)bit
- Single-in/Single-out, Dual-in/Single-out, and Dual-in/Dual-out selectable.
- AC coupling for high-speed lines
- CORE 1.8v, CMOS IO 3.3v
- Package: TFBGA105
- Wide frequency range
- CDR requires no external frequency reference
- 3.3V logic compatible output interface.

Si/So: Single-in/Single-out,
Di/So: Dual-in/Single-out, Di/Do: Dual-in/Single-out

Block Diagram

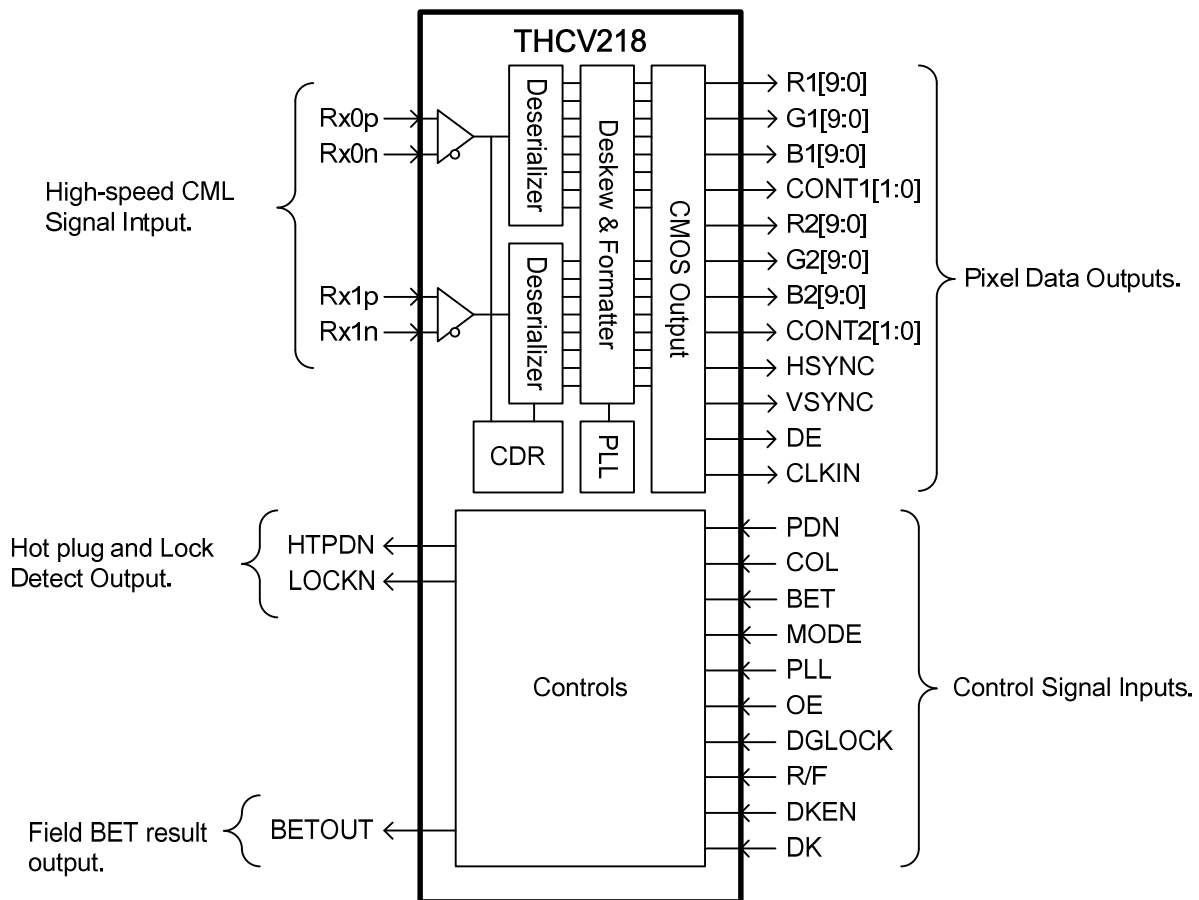

Example System Diagram

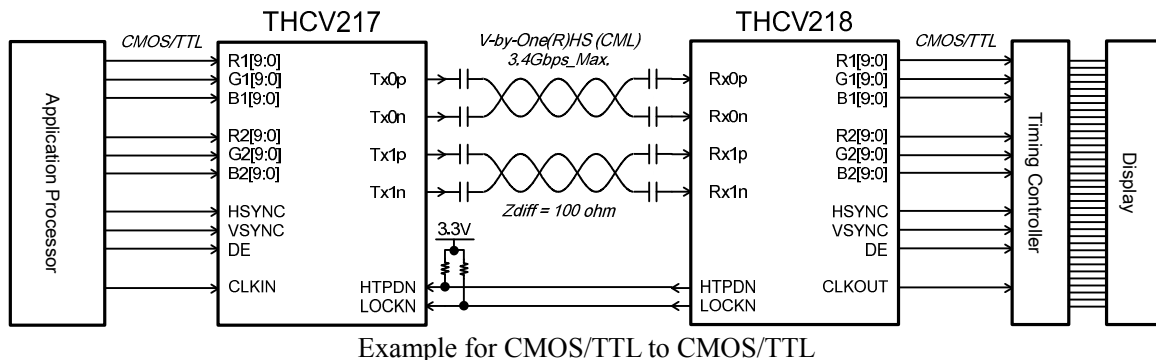

Example for CMOS/TTL to CMOS/TTL

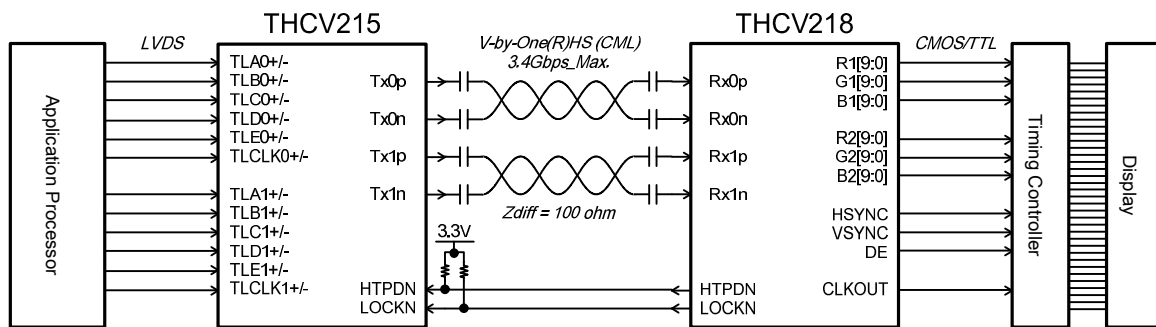

Example for LVDS to CMOS/TTL

Notices and Requests

1. The product specifications described in this material are subject to change without prior notice.
2. The circuit diagrams described in this material are examples of the application which may not always apply to the customer's design. We are not responsible for possible errors and omissions in this material. Please note if errors or omissions should be found in this material, we may not be able to correct them immediately.
3. This material contains our copy right, know-how or other proprietary. Copying or disclosing to third parties the contents of this material without our prior permission is prohibited.
4. Note that if infringement of any third party's industrial ownership should occur by using this product, we will be exempted from the responsibility unless it directly relates to the production process or functions of the product.
5. This product is presumed to be used for general electric equipment, not for the applications which require very high reliability (including medical equipment directly concerning people's life, aerospace equipment, or nuclear control equipment). Also, when using this product for the equipment concerned with the control and safety of the transportation means, the traffic signal equipment, or various Types of safety equipment, please do it after applying appropriate measures to the product.
6. Despite our utmost efforts to improve the quality and reliability of the product, faults will occur with a certain small probability, which is inevitable to a semi-conductor product. Therefore, you are encouraged to have sufficiently redundant or error preventive design applied to the use of the product so as not to have our product cause any social or public damage.
7. Please note that this product is not designed to be radiation-proof.
8. Customers are asked, if required, to judge by themselves if this product falls under the category of strategic goods under the Foreign Exchange and Foreign Trade Control Law.

THine Electronics, Inc.
sales@thine.co.jp



Стандарт Электрон Связь

Мы молодая и активно развивающаяся компания в области поставок электронных компонентов. Мы поставляем электронные компоненты отечественного и импортного производства напрямую от производителей и с крупнейших складов мира.

Благодаря сотрудничеству с мировыми поставщиками мы осуществляем комплексные и плановые поставки широчайшего спектра электронных компонентов.

Собственная эффективная логистика и склад в обеспечивает надежную поставку продукции в точно указанные сроки по всей России.

Мы осуществляем техническую поддержку нашим клиентам и предпродажную проверку качества продукции. На все поставляемые продукты мы предоставляем гарантию .

Осуществляем поставки продукции под контролем ВП МО РФ на предприятия военно-промышленного комплекса России , а также работаем в рамках 275 ФЗ с открытием отдельных счетов в уполномоченном банке. Система менеджмента качества компании соответствует требованиям ГОСТ ISO 9001.

Минимальные сроки поставки, гибкие цены, неограниченный ассортимент и индивидуальный подход к клиентам являются основой для выстраивания долгосрочного и эффективного сотрудничества с предприятиями радиоэлектронной промышленности, предприятиями ВПК и научно-исследовательскими институтами России.

С нами вы становитесь еще успешнее!

Наши контакты:

Телефон: +7 812 627 14 35

Электронная почта: sales@st-electron.ru

Адрес: 198099, Санкт-Петербург,
Промышленная ул, дом № 19, литера Н,
помещение 100-Н Офис 331