

# FTDI Chip

## UMFT4222PROG-IC

### FT4222

## Programmer Module



## 1 Introduction

The UMFT4222PROG-IC Programmer Module has been developed to aid programming OTP memory in the FT4222H.

The internal OTP memory in the FT4222H is used to store USB Vendor ID (VID), Product ID (PID), device serial number, product description string and various other USB configuration descriptors.

The UMFT4222PROG-IC Programmer Module is designed with the FTDI FT51. The FT51 downstream USB port is connected to the FT4222H programming socket.

The user places the FT4222H DUT in the socket, starts the programming application on the host PC which controls the main power and the OTP program power to the FT4222H. When the FT4222H is programmed and verified, the application turns off the main power and OTP programming power for safe removal of the FT4222H from the socket.

### 1.1 Features

- USB2.0 Full Speed compatible,
- Standard USB MicroB receptacle.
- Single USB power input, built-in DC-DC converter for 6.5 V OTP programming power and main operation power supply.
- Quick and easy FT4222H OTP data production programming – drop in the FT4222H IC to be programmed, the application controls the power supplies, programming and power off automatically.
- Visual indicator for 6.5V programming voltage and USB bus power using LEDs

## 2 Module Information

### 2.1 Driver Support

- Microsoft Windows 8 and 8 - 64-bit
- Microsoft Windows 7 and Windows 7 64-bit

The drivers listed above are all available to download for free from:  
<http://www.ftdichip.com/Drivers/D2XX.htm>

### 2.2 Ordering Information

The following Table 2-1 gives details of the available UMFT4222PROG-IC.

Part Number	Description
UMFT4222PROG-IC	FT4222H OTP memory programming module

**Table 2-1 UMFT4222PROG-IC Descriptions and Part Numbers**

---

## FigureTable of Contents

<b>1</b>	<b>Introduction .....</b>	<b>1</b>
<b>1.1</b>	<b>Features.....</b>	<b>1</b>
<b>2</b>	<b>Module Information.....</b>	<b>2</b>
<b>2.1</b>	<b>Driver Support .....</b>	<b>2</b>
<b>2.2</b>	<b>Ordering Information.....</b>	<b>2</b>
<b>3</b>	<b>Function Description.....</b>	<b>4</b>
<b>3.1</b>	<b>Connection with UMFT4222PROG-IC.....</b>	<b>5</b>
<b>3.2</b>	<b>LED Indicators .....</b>	<b>5</b>
<b>4</b>	<b>UMFT4222PROG-IC module connection and Mechanical Details .....</b>	<b>6</b>
<b>5</b>	<b>Module PCB Circuit Schematic .....</b>	<b>7</b>
<b>6</b>	<b>Contact Information .....</b>	<b>9</b>
	<b>Appendix A – References .....</b>	<b>10</b>
	<b>Appendix B –List of Figures and Tables .....</b>	<b>11</b>
	<b>Appendix C - Revision History .....</b>	<b>12</b>

### 3 Function Description

The UMFT4222 Programmer IC Module (UMFT4222PROG-IC) is designed for production programming the FT4222H OTP memory. This module is designed with the FTDI FT51 chip. The FT51 built-in hub downstream port connects the FT4222H DUT to the host PC, while the FT51 built-in USB function manages the functional and OTP programming power (VPP) supplies to the FT4222H socket.

The operation to program the FT4222H with UMFT4222PROG-IC is as follows:

- Connect the module to the host PC - the UMFT4222H-IC is in standby mode and the power supply to the DUT socket is turned off.
- Place a FT4222H DUT in the socket
- Close the socket cover.
- Run the free FTDI programming utility, FT\_PROG, to update the FT4222H OTP data.

When FT\_PROG starts to update the FT4222H OTP, it performs the following steps:

- Turn on the power.
- Complete the programming.
- Automatically turn off the power supply.

For more details about FT\_PROG, please refer to the utilities section of the [FTDI website](#).

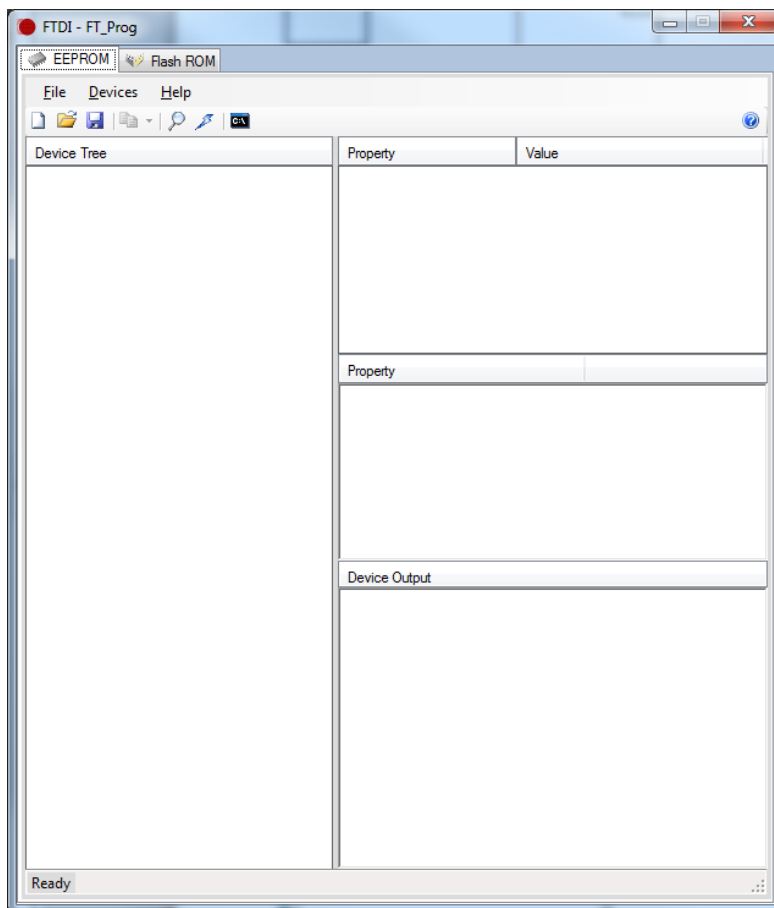

**Figure 3-1 UMFT4222PROG-IC connection example**

### 3.1 Connection with UMFT4222PROG-IC

The FT4222H supports +5V to +3.3V output from an integrated LDO regulator.

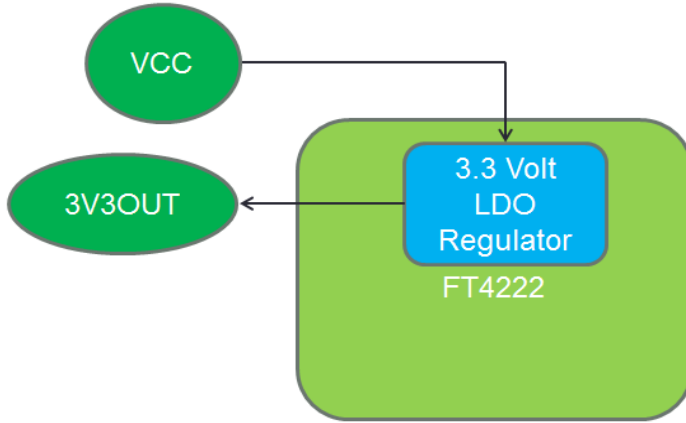

**Figure3-2 Example Function block of FT4222H integrated LDO regulator**

### 3.2 LED Indicators

The UMFT4222PROG-IC programmer has 1 LED. Table 3.1 describes the function of the LEDs.

LED NAME	Color	LED OFF	LED ON
D2	Red	No indication	Burn in user data to FT4222 OTP block.

**Table 3-1 UMFT4222PROG-IC LED Indication**

## 4 UMFT4222PROG-IC module connection and Mechanical Details

The following Figure 4-1 UMFT4222PROG-IC module layout shows the UMFT4222PROG-IC module layout. The module dimensions are 76.42mm x 44.48mm.

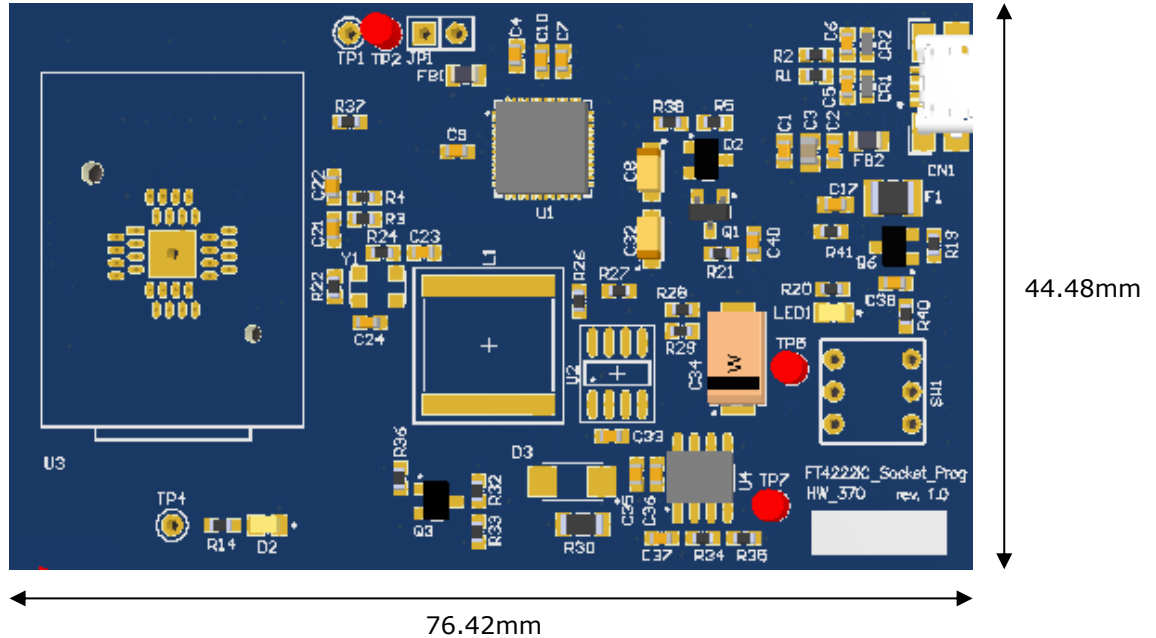

**Figure4-1 UMFT4222PROG-IC module layout**

The following Table 4-1 shows the module signals for these signals on the UMFT4222PROG-IC module.

Pin No.	Name	Type	Description
SW1	VBUS	PWR	Control U3 Main Power
TP5	DP_VBUS	PWR	Support U3 Main Power
TP1,TP7	GND	PWR	Ground
TP4	VPP	PWR	6.5V Voltage supply

**Table 4-1 UMFT4222PROG module Connections (numbers refer to pad numbers on the PCB)**

## 5 Module PCB Circuit Schematic

The circuit schematics for the small electronic board, utilising the FTDI FT51, are shown in Figure 5-1.

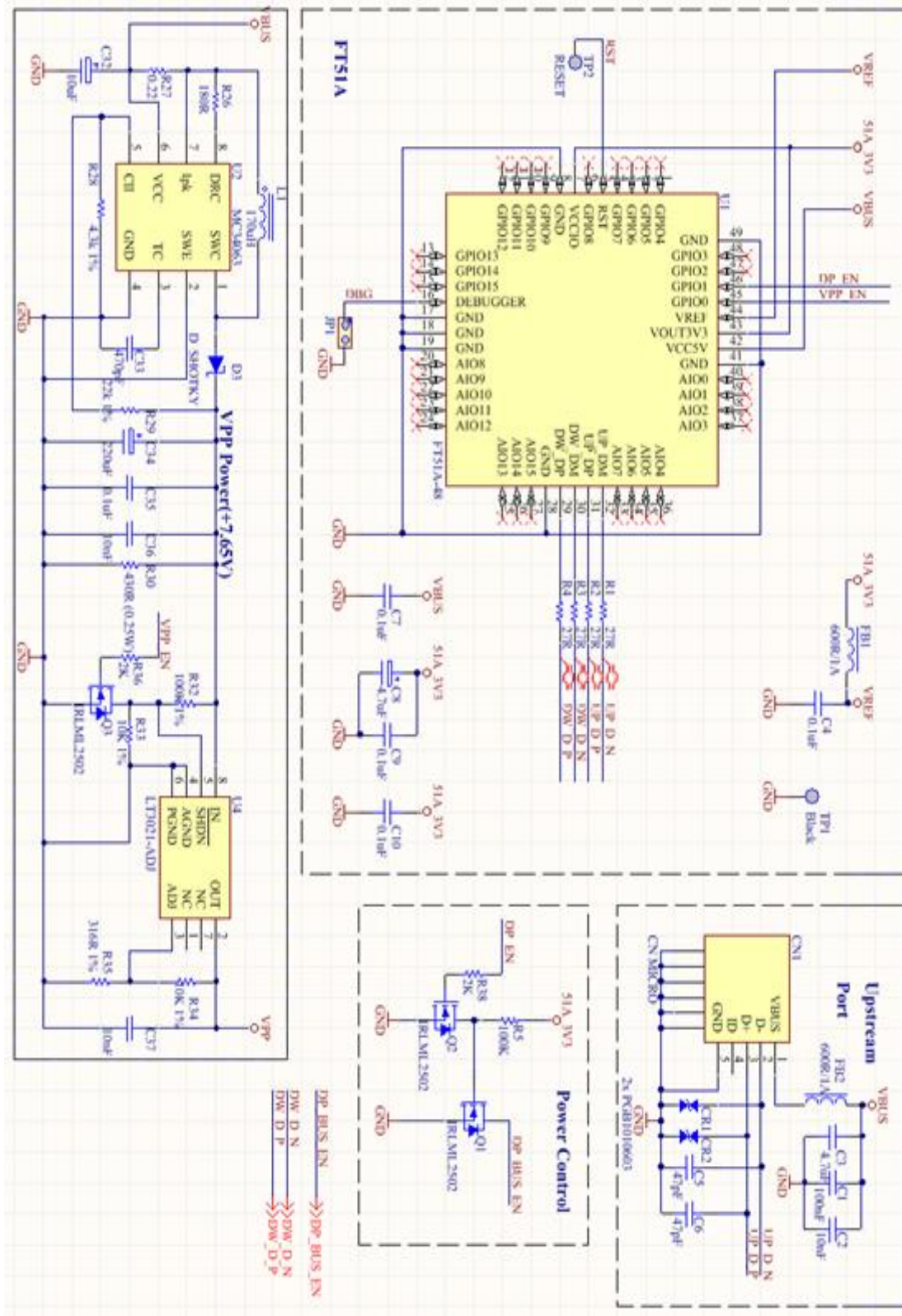

Figure5-1 Circuit Schematic of UMFT4222PROG-IC

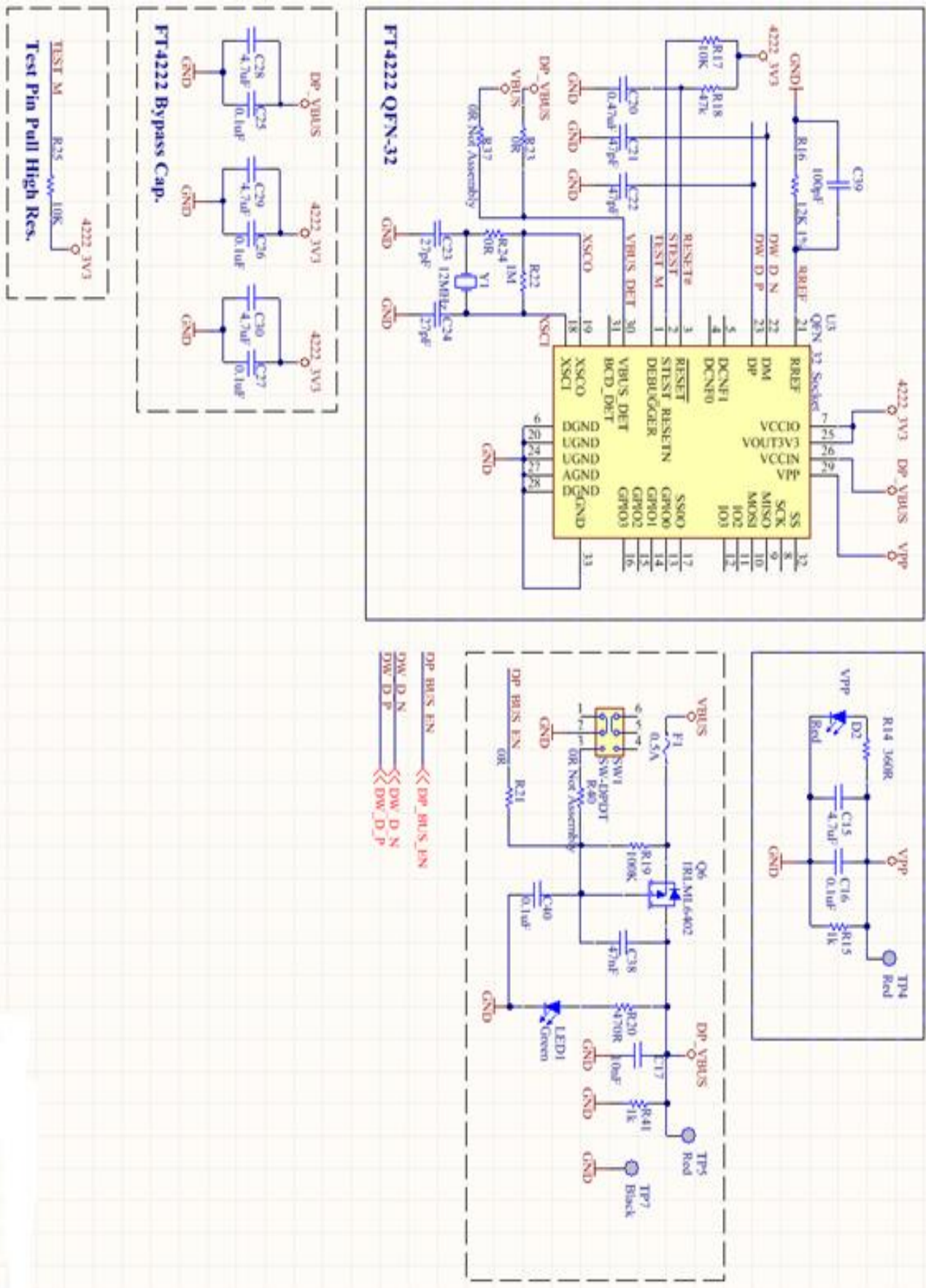

Figure5-2 Circuit Schematic of UMFT4222PROG-IC



## 6 Contact Information

### Head Office – Glasgow, UK

Future Technology Devices International Limited  
Unit 1, 2 Seaward Place, Centurion Business Park  
Glasgow G41 1HH  
United Kingdom  
Tel: +44 (0) 141 429 2777  
Fax: +44 (0) 141 429 2758

E-mail (Sales) [sales1@ftdichip.com](mailto:sales1@ftdichip.com)  
E-mail (Support) [support1@ftdichip.com](mailto:support1@ftdichip.com)  
E-mail (General Enquiries) [admin1@ftdichip.com](mailto:admin1@ftdichip.com)

### Branch Office – Taipei, Taiwan

Future Technology Devices International Limited  
(Taiwan)  
2F, No. 516, Sec. 1, NeiHu Road  
Taipei 114  
Taiwan, R.O.C.  
Tel: +886 (0) 2 8791 3570  
Fax: +886 (0) 2 8791 3576

E-mail (Sales) [tw.sales1@ftdichip.com](mailto:tw.sales1@ftdichip.com)  
E-mail (Support) [tw.support1@ftdichip.com](mailto:tw.support1@ftdichip.com)  
E-mail (General Enquiries) [tw.admin1@ftdichip.com](mailto:tw.admin1@ftdichip.com)

### Branch Office – Tigard, Oregon, USA

Future Technology Devices International Limited  
(USA)  
7130 SW Fir Loop  
Tigard, OR 97223  
USA  
Tel: +1 (503) 547 0988  
Fax: +1 (503) 547 0987

E-Mail (Sales) [us.sales@ftdichip.com](mailto:us.sales@ftdichip.com)  
E-Mail (Support) [us.support@ftdichip.com](mailto:us.support@ftdichip.com)  
E-Mail (General Enquiries) [us.admin@ftdichip.com](mailto:us.admin@ftdichip.com)

### Branch Office – Shanghai, China

Room 1103, No. 666 West Huaihai Road,  
Changning District  
Shanghai, 200052  
China  
Tel: +86 21 62351596  
Fax: +86 21 62351595

E-mail (Sales) [cn.sales@ftdichip.com](mailto:cn.sales@ftdichip.com)  
E-mail (Support) [cn.support@ftdichip.com](mailto:cn.support@ftdichip.com)  
E-mail (General Enquiries) [cn.admin@ftdichip.com](mailto:cn.admin@ftdichip.com)

### Web Site

<http://ftdichip.com>

System and equipment manufacturers and designers are responsible to ensure that their systems, and any Future Technology Devices International Ltd (FTDI) devices incorporated in their systems, meet all applicable safety, regulatory and system-level performance requirements. All application-related information in this document (including application descriptions, suggested FTDI devices and other materials) is provided for reference only. While FTDI has taken care to assure it is accurate, this information is subject to customer confirmation, and FTDI disclaims all liability for system designs and for any applications assistance provided by FTDI. Use of FTDI devices in life support and/or safety applications is entirely at the user's risk, and the user agrees to defend, indemnify and hold harmless FTDI from any and all damages, claims, suits or expense resulting from such use. This document is subject to change without notice. No freedom to use patents or other intellectual property rights is implied by the publication of this document. Neither the whole nor any part of the information contained in, or the product described in this document, may be adapted or reproduced in any material or electronic form without the prior written consent of the copyright holder. Future Technology Devices International Ltd, Unit 1, 2 Seaward Place, Centurion Business Park, Glasgow G41 1HH, United Kingdom. Scotland Registered Company Number: SC136640

## Appendix A – References

FT4222H Datasheet

[http://www.ftdichip.com/Support/Documents/DataSheets/ICs/DS\\_FT4222H.pdf](http://www.ftdichip.com/Support/Documents/DataSheets/ICs/DS_FT4222H.pdf)

## Acronyms and Abbreviations

Terms	Description
IC	Integrated Circuit
DUT	Device Under Test
LED	Light Emitting Diode
OTP	One Time Programmable
USB	Universal Serial Bus

## Appendix B –List of Figures and Tables

### List of Figures

Figure 3-1 UMFT4222PROG-IC connection example .....	4
Figure3-2 Example Function block of FT4222H integrated LDO regulator .....	5
Figure4-1 UMFT4222PROG-IC module layout .....	6
Figure5-1 Circuit Schematic of UMFT4222PROG-IC .....	7
Figure5-2 Circuit Schematic of UMFT4222PROG-IC .....	8

### List of Tables

Table 2-1 UMFT4222PROG-IC Descriptions and Part Numbers .....	2
Table 3-1 UMFT4222PROG-IC LED Indication .....	5
Table 4-1 UMFT4222PROG module Connections (numbers refer to pad numbers on the PCB)..	6

## Appendix C - Revision History

Document Title: UMFT4222 Programmer-IC Module Datasheet  
Document Reference No.: FT\_001132  
Clearance No.: FTDI#427  
Product Page: <http://www.ftdichip.com/FTProducts.html>  
Document Feedback: [DS\\_UMFT4222PROG-IC](#)

**Version 1.0** Initial Release 2014-12-03



## Стандарт Электрон Связь

Мы молодая и активно развивающаяся компания в области поставок электронных компонентов. Мы поставляем электронные компоненты отечественного и импортного производства напрямую от производителей и с крупнейших складов мира.

Благодаря сотрудничеству с мировыми поставщиками мы осуществляем комплексные и плановые поставки широчайшего спектра электронных компонентов.

Собственная эффективная логистика и склад в обеспечивает надежную поставку продукции в точно указанные сроки по всей России.

Мы осуществляем техническую поддержку нашим клиентам и предпродажную проверку качества продукции. На все поставляемые продукты мы предоставляем гарантию .

Осуществляем поставки продукции под контролем ВП МО РФ на предприятия военно-промышленного комплекса России , а также работаем в рамках 275 ФЗ с открытием отдельных счетов в уполномоченном банке. Система менеджмента качества компании соответствует требованиям ГОСТ ISO 9001.

Минимальные сроки поставки, гибкие цены, неограниченный ассортимент и индивидуальный подход к клиентам являются основой для выстраивания долгосрочного и эффективного сотрудничества с предприятиями радиоэлектронной промышленности, предприятиями ВПК и научно-исследовательскими институтами России.

С нами вы становитесь еще успешнее!

### Наши контакты:

**Телефон:** +7 812 627 14 35

**Электронная почта:** [sales@st-electron.ru](mailto:sales@st-electron.ru)

**Адрес:** 198099, Санкт-Петербург,  
Промышленная ул, дом № 19, литера Н,  
помещение 100-Н Офис 331