

PRODUCT NO.
10108777-X0XXXX

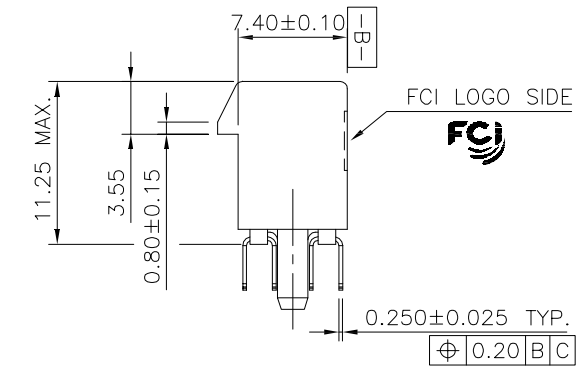

TWIN PLASTIC PEG TYPE

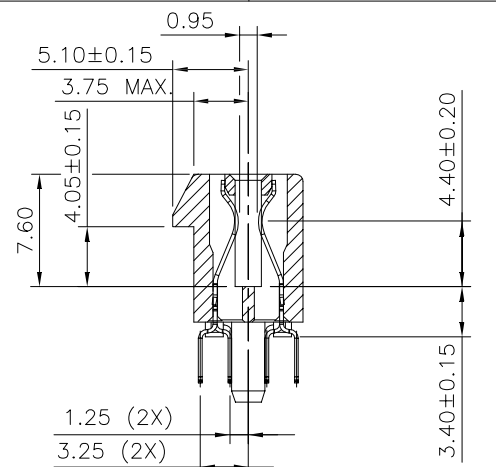
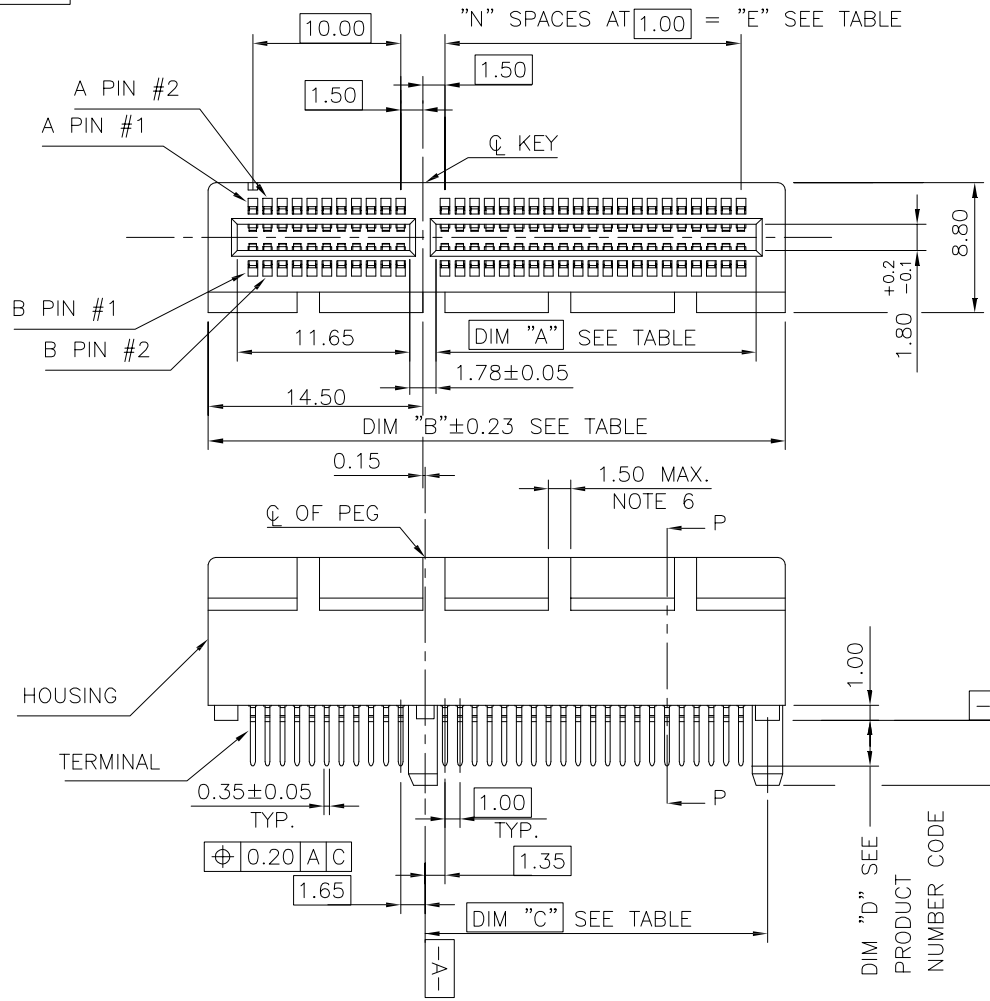
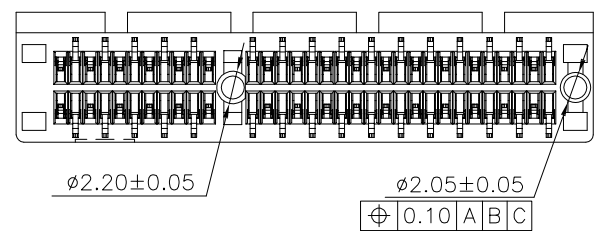

mat'l. code				tolerances unless otherwise specified				CUSTOMER COPY		FCI		www.fciconnect.com		
ltr	ecn no	dr	date	linear	.X ± 0.30		projection	title	PCI EXPRESS GEN3 CARD EDGE ASSY		product family EDGE CARD		code TWN	
A	T09-1162	J H	10/29/09		.XX ± 0.20									
B	T-004920	J H	6/8/11		.XXX ± 0.10									
C	DG-011582	HT	5/10/12	angles	0° ± 2°		scale		A4		sheet 1 of 7			
D	ELX-DG-013209	WL	07/24/12	dr	STONE LI	05/27/15	MM		size dwg no		10108777			
E	ELX-DG-21161-1	ST	05/27/15	enrg	STONE LI	05/27/15	2:1							
				chr	/	/								
				appd	PM ZHENG	05/27/15								
sheet index	revision sheet	E 1	E 2	E 3	E 4	E 5	E 6	E 7	cage code		4			

PRODUCT NO.
10108777-X2XXXX

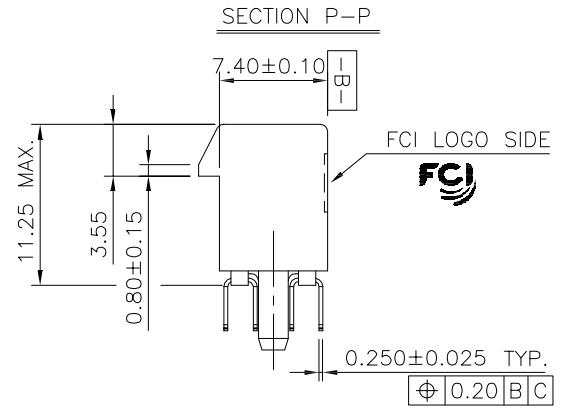
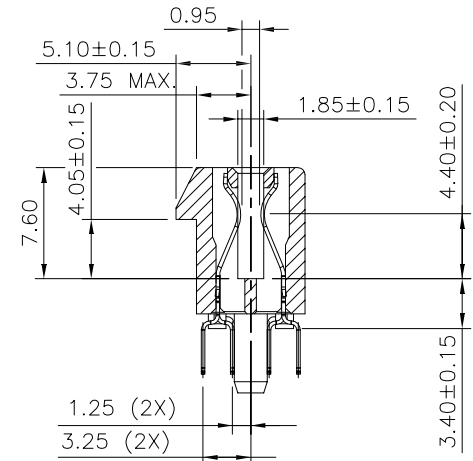
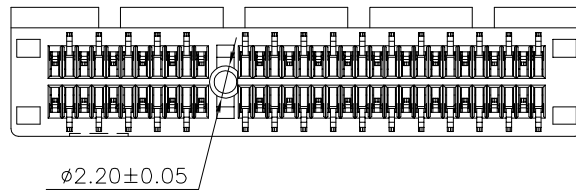
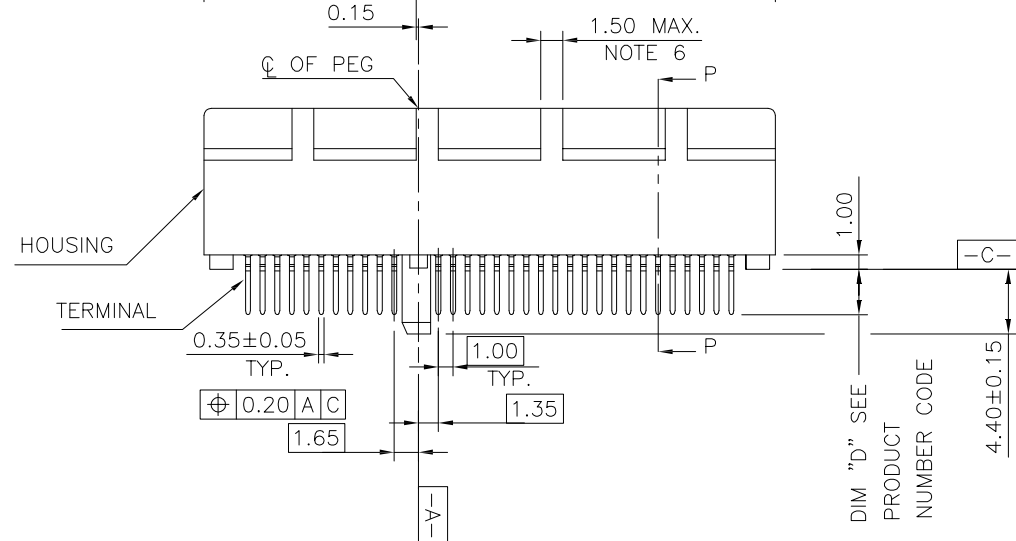
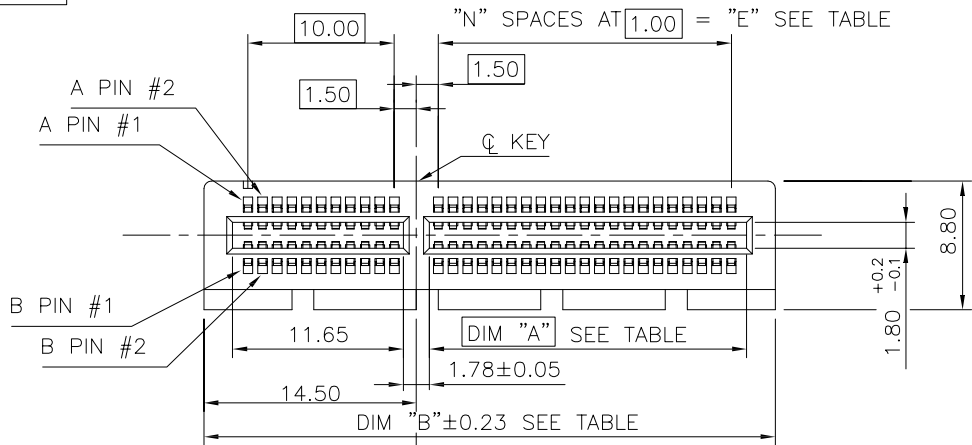

SINGLE PLASTIC PEG TYPE

mat'l. code				tolerances unless otherwise specified			CUSTOMER COPY		FCI www.fciconnect.com	
ltr	ecn no	dr	date	linear	.X ± 0.30	projection 	title PCI EXPRESS GEN3 CARD EDGE ASSY			
					.XX ± 0.20					
				angles	.XXX ± 0.10					
					0° ± 2°	MM ←→ scale 2:1	product family EDGE CARD		code TWN	
				dr	STONE LI 05/27/15		size dwg no		sheet 2 of	
				enr	STONE LI 05/27/15		A4		10108777	
				chr	/ /					
				appd	PM ZHENG 05/27/15					
sheet index	revision sheet									

cage code

PRODUCT NO.
10108777-X1XXXX

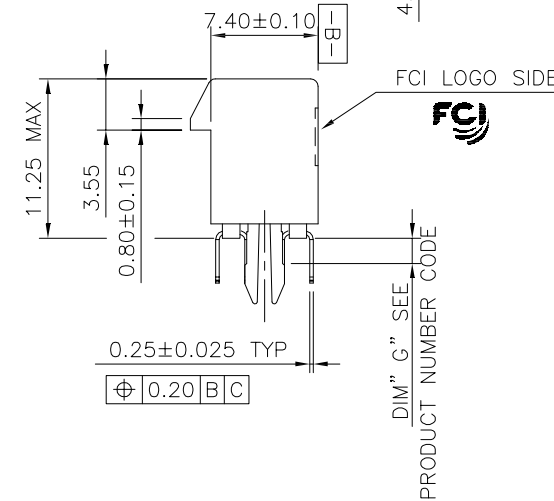
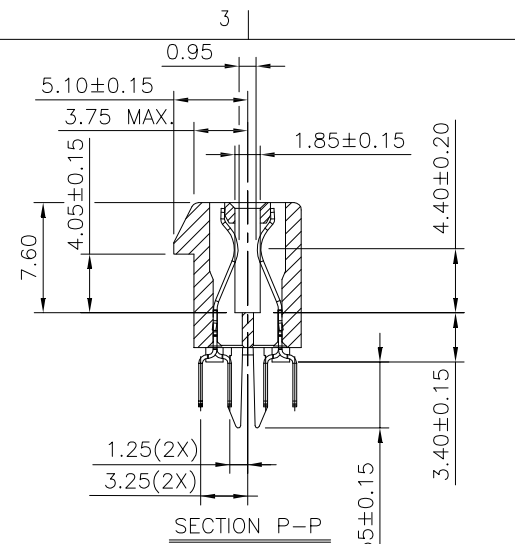
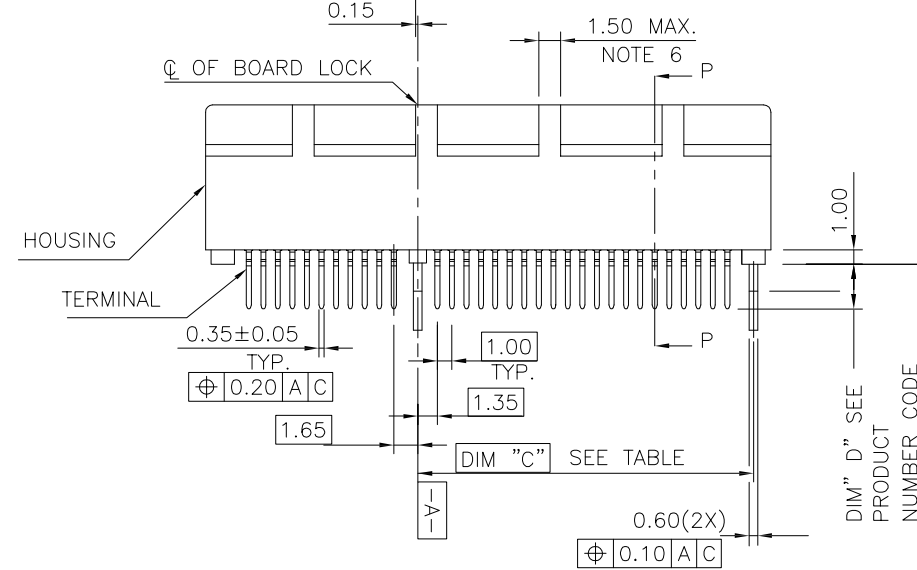
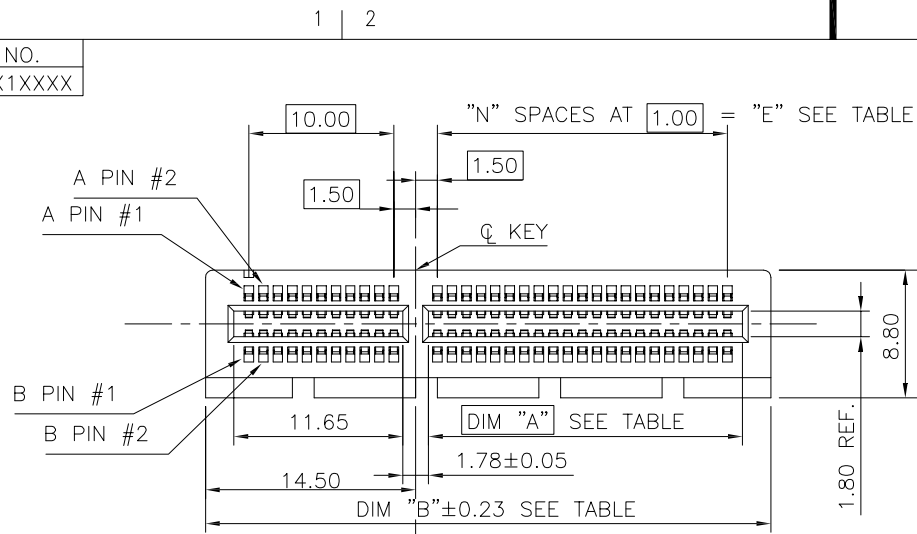

METAL BOARD LOCKS TYPE

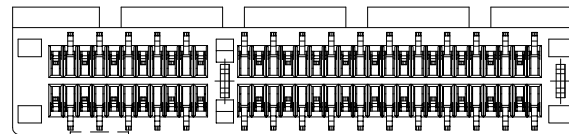

mat'l. code				tolerances unless otherwise specified		CUSTOMER COPY		FCI www.fciconnect.com	
ltr	ecn no	dr	date	linear	.X ± 0.30	projection	title PCI EXPRESS GEN3 CARD EDGE ASSY		
				angles	.XX ± 0.20		product family EDGE CARD code TWN		
				dr	.XXX ± 0.10		MM	size dwg no	
				enfr	0° ±2°	scale	A4 10108777		sheet 3 of
				chr		2:1			
				appd					
sheet index	revision sheet						cage code		

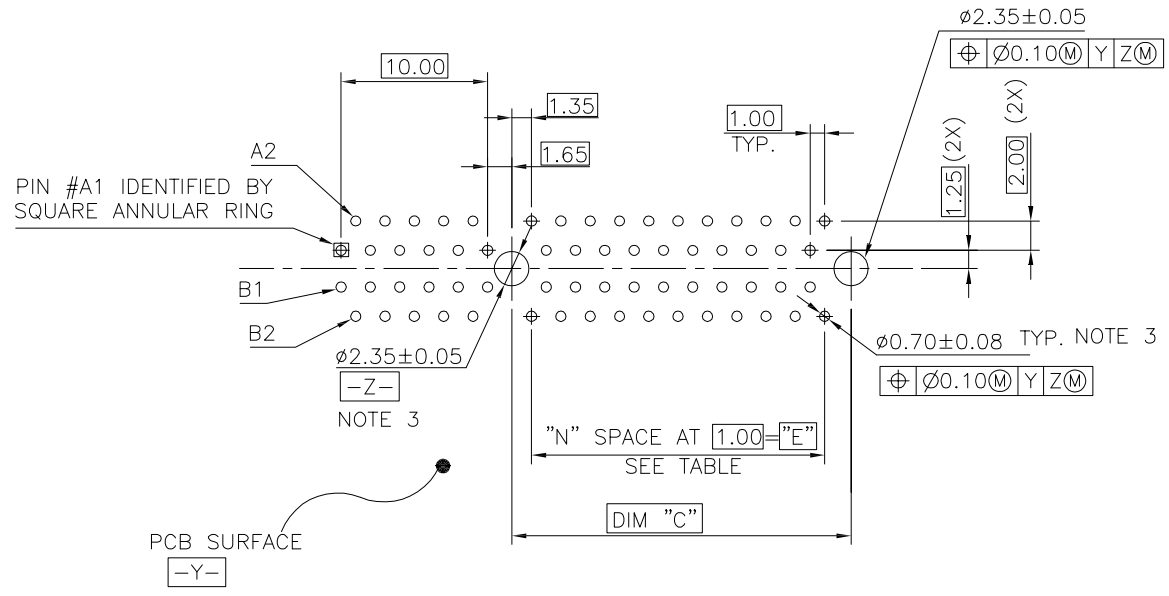

← I/O PANEL DIRECTION

RECOMMENDED FOOTPRINT

mat'l. code				tolerances unless otherwise specified			CUSTOMER COPY	 www.fcconnect.com		
ltr	ecn no	dr	date	linear	.X ±		projection	title		
					.XX ±			PCI EXPRESS GEN3 CARD EDGE ASS'Y		
					.XXX ±				product family EDGE CARD	
				angles	0° ±2°		code TWN			
				dr	STONE LI	05/27/15		size		
				enr	STONE LI	05/27/15		dwg no		
				chr	/	/	scale	A4 10108777		
				appd	PM ZHENG	05/27/15		sheet 4 of		
sheet index	revision sheet						cage code			

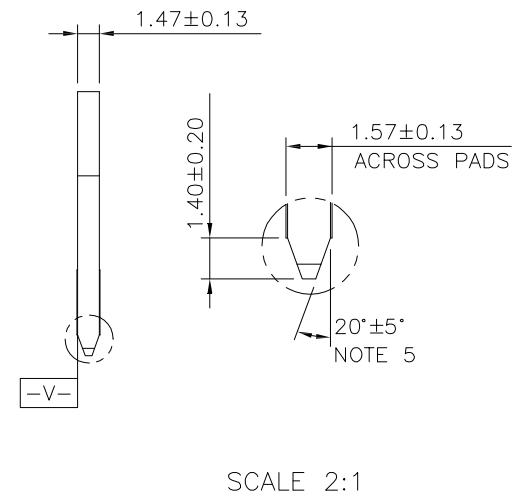
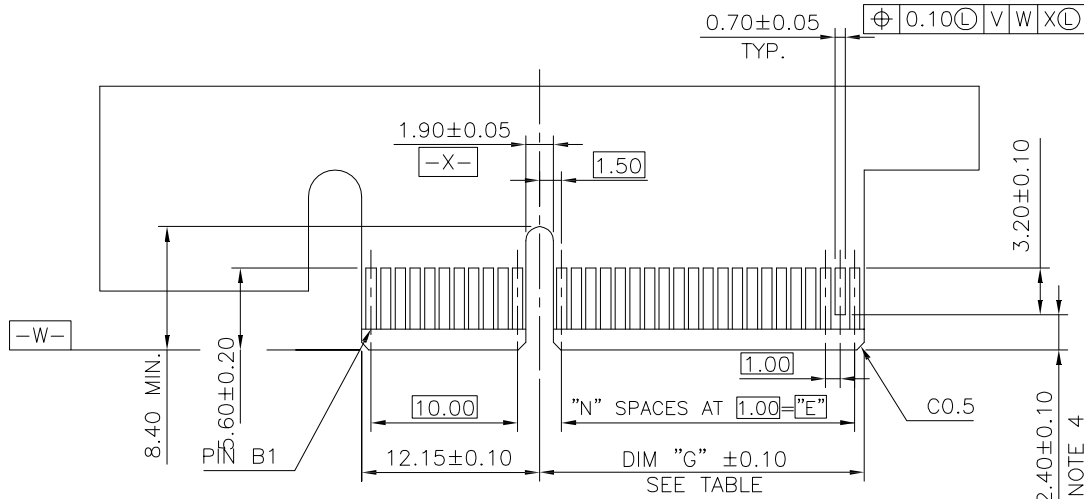

← I/O PANEL DIRECTION
PRIMARY (COMPONENT) SIDE

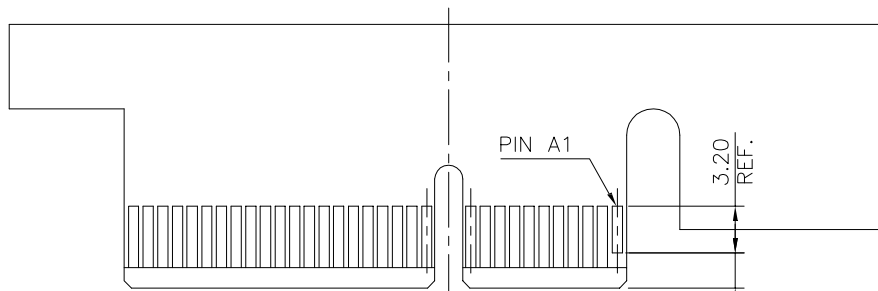

I/O PANEL DIRECTION →
SECONDARY (SOLDER) SIDE

ADD-IN CARD EDGE-FINGER DIMENSIONS

#	POS	REF.	N	DIM "G"	"F"
36			6	8.15	B17
64			20	22.15	B31
98			37	39.15	B48
164			70	72.15	B81

PIN "F" SEE TABLE

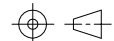
mat'l. code				tolerances unless otherwise specified				CUSTOMER COPY		 www.fciconnect.com		
ltr	ecn no	dr	date	linear	.X ±		projection	title				
					.XX ±			PCI EXPRESS GEN3				
					.XXX ±			CARD EDGE ASS'Y				
				angles	0° ±2°		 MM	product family		EDGE CARD		code
				dr	STONE LI	05/27/15		size		dwg no		TWN
				enr	STONE LI	05/27/15		scale		A4		10108777
				chr	/	/						sheet
				appd	PM ZHENG	05/27/15	2:1				5 of	
sheet index	revision sheet											cage code

NOTES:

1.MATERIAL:

HOUSING: HIGH TEMPERATURE NYLON, GLASS FILLED UL94V-0 RATED.
TERMINAL: COPPER ALLOY.

PLATING: 50u" NICKEL UNDERPLATE ALL OVER
CONTACT AREA PLATING - SEE PRODUCT NUMBER CODE
SOLDER TAIL: TIN OR TIN /LEAD(90/10)- SEE PRODUCT
NUMBER CODE 100u" MIN. OVER 50u" NICKEL.

METAL BOARD LOCKS: COPPER ALLOY.
FINISH: 100u" TIN OR TIN/LEAD(90/10) OVER 50u" NICKEL
UNDERPLATE SEE PRODUCT NUMBER CODE.

2.PRODUCT SPECIFICATION: GS-12-233.

③THE HORIZONTAL AXIS FOR THE HOLE PATTERN IS ESTABLISHED BY

A LINE THROUGH THE CENTER OF THE TWO Ø2.35 HOLES.
THE VERTICAL AXIS IS 90° TO THE HORIZONTAL AXIS, THROUGH THE CENTER
OF DATUM Z.

④NO TIE BAR PERMITTED FROM CARD EDGE TO LEADING EDGE OF PAD FOR PINS A1 AND PIN NUMBERS "F".

⑤CHAMFER EDGES MUST BE FREE OF CUTTING BURRS.

⑥FREQUENCY & LOCATION AT SUPPLIER DISCRETION. RIDGE MAY BE CONTINUOUS WITH NO BREAKS.

7.RoHS COMPATIBLE PRODUCT SPECIFICATIONS:

a - PLATING:

- "LF" MEANS THE PRODUCT IS LEAD-FREE, 2um MINIMUM MATTE TIN OVER 1.27um
MINIMUM NICKEL UNDERPLATE.

b - MANUFACTURING PROCESS COMPATIBILITY:

- THE HOUSING WILL WITHSTAND EXPOSURE TO 260°C±5°C TEMPERATURE FOR
10 SECONDS IN RE-FLOW APPLICATION, SEE NOTE 8 FOR APPLICATION.

CONNECTOR	# POS	REF. N	DIM "A"	DIM "B"	DIM "C"	"E"
1 PORT	36	6	7.65	25.00	9.15	6.00
4 PORT	64	20	21.65	39.00	23.15	20.00
8 PORT	98	37	38.65	56.00	40.15	37.00
16 PORT	164	70	71.65	89.00	73.15	70.00

8.AN ADEQUATE PROCEDURE SET FORTH IN THE FOLLOWING ENSURE THAT THE PRODUCT
RELIABILITY CAN BE ACHIEVED DURING AND AFTER PCB ASSEMBLY OPERATION.

8.1IF PARTIAL LOT ARE USED, THE REMAINING CONNECTORS MUST BE RESEALED AND
PLACED IN SAFE STORAGE WITHIN SIX HOURS OF BAG OPENING.

8.2THE SAFE STORAGE CONDITION IS RECOMMENDED AT 25°C, 40%RH.

8.3NOT FOLLOWING THE PROCEDURE MAY CAUSE BLISTER DAMAGE DURING RE-FLOW PROCESS.

8.4IF BAKING IS REQUIRED, CONNECTOR SHALL BE BAKED FOR 4 HOURS AT 125°C.

8.5REFERENCE SPECIFICATION: IPC/JEDEC J-STD-033A.

PRODUCT NUMBER CODE

10108777 -X X X X X □ □

HOUSING COLOR OPTIONS

- 0-NATURAL
- 1-BLACK

PEGS OPTIONS

- 0-PLASTIC PEGS
- 1-METAL BOARD LOCKS
- 2-SINGLE PLASTIC PEGS

TERMINAL PLATING OPTIONS

- 0-50u" Ni UNDERPLATE
30u" Au CONTACT AREA
100u" TIN TAIL AREA ----- COMPATIBLE RoHS
- 1-50u" Ni UNDERPLATE
15u" Au CONTACT AREA
100u" TIN TAIL AREA ----- COMPATIBLE RoHS
- 2-50u" Ni UNDERPLATE
GOLD FLASH CONTACT AREA
100u" TIN TAIL AREA ----- COMPATIBLE RoHS
- 3-50u" Ni UNDERPLATE
30u" Au CONTACT AREA
100u" TIN/LEAD TAIL AREA ----- INCOMPLIANT RoHS
- 4-50u" Ni UNDERPLATE
15u" Au CONTACT AREA
100u" TIN/LEAD TAIL AREA ----- INCOMPLIANT RoHS
- 5-50u" Ni UNDERPLATE
GOLD FLASH CONTACT AREA
100u" TIN/LEAD TAIL AREA ----- INCOMPLIANT RoHS

LEAD FREE OPTION

LEAVE BLANK FOR TERMINAL PLATING 3,4,5
"LF" FOR TERMINAL PLATING OPTION 0,1,2

POS OPTIONS

- 0-36
- 1-64
- 2-98
- 3-164

PACKAGING OPTIONS

- T-SOFT TRAY PACKAGING
- M-SOFT TRAY PACKAGING & MYLAR TAPE. SEE FIGULE 1
- Y-HARD TRAY PACKAGING (FOR 164P ONLY)
- Z-HARD TRAY PACKAGING WITH MYLAR (FOR 164P ONLY)
- R-TAPE & REEL PACKAGING WITHOUT MYLAR (FOR 34, 64, 98P ONLY)
- W-TAPE & REEL PACKAGING WITHOUT MYLAR (FOR 98P ONLY), WITH 18.0MM CAVITY WIDTH
- A-TAPE & REEL PACKAGING WITH MYLAR (FOR 36, 64, 98P)

TAIL LENGTH OPTIONS

	DIM "D"	PCB THICKNESS	BOARD LOCKS DIM "G"
0	2.30 ^{+0.25} / _{-0.13}	1.56±0.10	1.70±0.15
1	3.10 ^{+0.25} / _{-0.13}	2.36±0.10	2.50±0.15
2	2.54±0.25	1.56±0.10	1.70±0.15
3	1.90±0.25	1.56±0.10	1.70±0.15
4	3.10 ^{+0.25} / _{-0.13}	2.0±0.10	1.70±0.15

mat'l. code				tolerances unless otherwise specified		CUSTOMER COPY		FCI	
ltr	ecn no	dr	date	linear	.X ±	projection	www.fciconnect.com		
					.XX ±		title PCI EXPRESS GEN3 CARD EDGE ASSY		
				angles	.XXX ±				
					0° ±2°				
		dr	STONE LI	05/27/15		MM	product family	EDGE CARD	code
		enfr	STONE LI	05/27/15			size	dwg no	TWN
		chr	/	/		scale	10108777		sheet
		appd	PM ZHENG	05/27/15		1:1			6 of 7
sheet index	revision sheet								

cage code

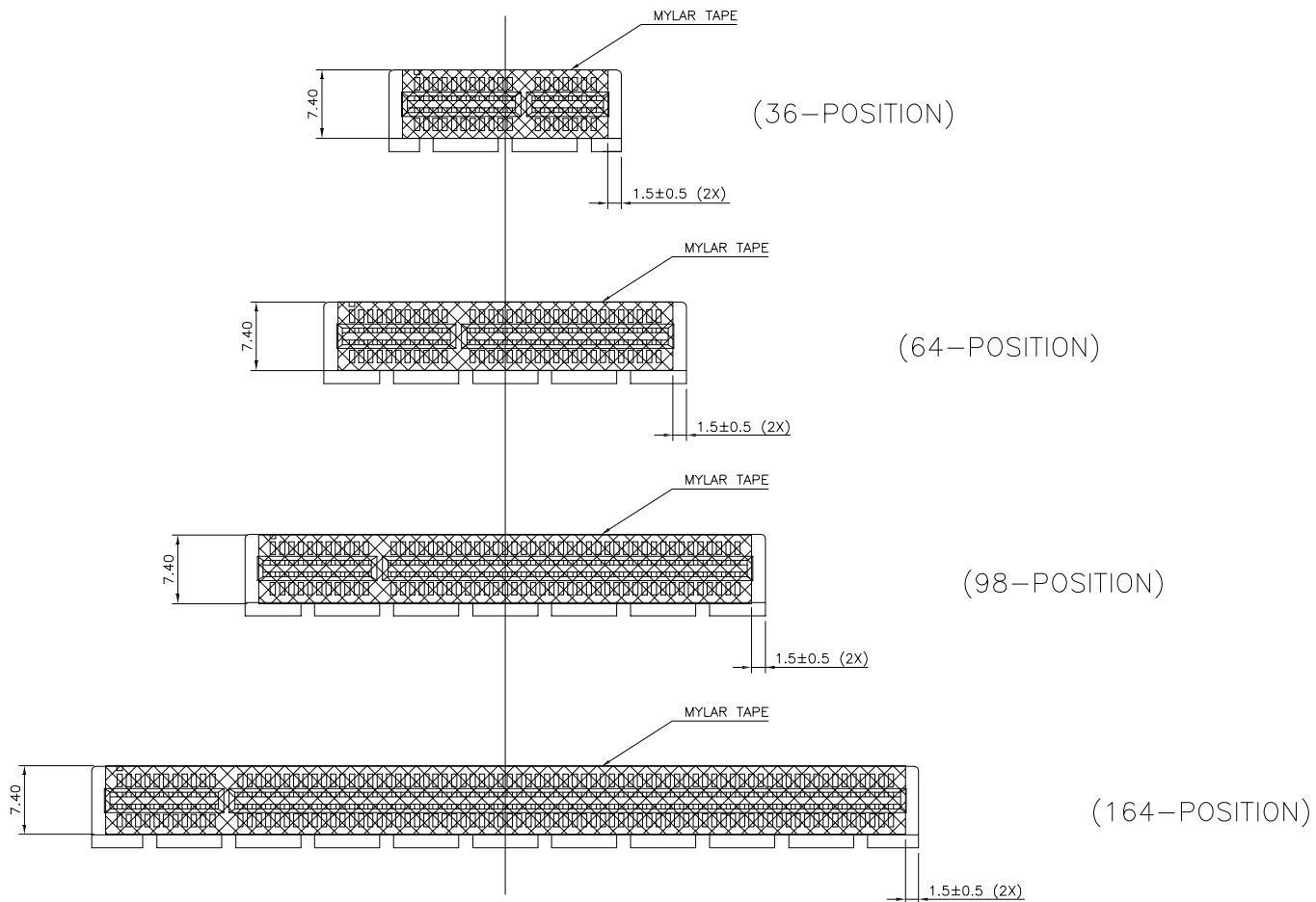

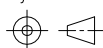

FIGURE 1

mat'l. code				tolerances unless otherwise specified		CUSTOMER COPY	 www.fciconnect.com		
ltr	ecn no	dr	date	linear	.X ± 0.25			projection	title
					.XX ± 0.13		PCI EXPRESS GEN3 CARD EDGE ASS'Y		
				angles	.XXX ± 0.05				
					0° ±2°	← MM →	product family	EDGE CARD	code
				dr	STONE LI 05/27/15		scale	size	dwg no
				enr	STONE LI 05/27/15	1.5:1	A4	10108777	sheet
				chr	/ /				7 of
				appd	PM ZHENG 05/27/15				
sheet index	revision sheet								

cage code



Стандарт Электрон Связь

Мы молодая и активно развивающаяся компания в области поставок электронных компонентов. Мы поставляем электронные компоненты отечественного и импортного производства напрямую от производителей и с крупнейших складов мира.

Благодаря сотрудничеству с мировыми поставщиками мы осуществляем комплексные и плановые поставки широчайшего спектра электронных компонентов.

Собственная эффективная логистика и склад в обеспечивает надежную поставку продукции в точно указанные сроки по всей России.

Мы осуществляем техническую поддержку нашим клиентам и предпродажную проверку качества продукции. На все поставляемые продукты мы предоставляем гарантию .

Осуществляем поставки продукции под контролем ВП МО РФ на предприятия военно-промышленного комплекса России , а также работаем в рамках 275 ФЗ с открытием отдельных счетов в уполномоченном банке. Система менеджмента качества компании соответствует требованиям ГОСТ ISO 9001.

Минимальные сроки поставки, гибкие цены, неограниченный ассортимент и индивидуальный подход к клиентам являются основой для выстраивания долгосрочного и эффективного сотрудничества с предприятиями радиоэлектронной промышленности, предприятиями ВПК и научно-исследовательскими институтами России.

С нами вы становитесь еще успешнее!

Наши контакты:

Телефон: +7 812 627 14 35

Электронная почта: sales@st-electron.ru

Адрес: 198099, Санкт-Петербург,
Промышленная ул, дом № 19, литера Н,
помещение 100-Н Офис 331