



QUICKSWITCH® PRODUCTS
HIGH-SPEED CMOS
QUICKSWITCH
8-BIT BUS SWITCH

IDTQS3245

FEATURES:

- Enhanced N channel FET with no inherent diode to Vcc
- 5Ω bidirectional switches connect inputs to outputs
- Pin compatible with the 74F245, 74FCT245, and 74FCT245T
- Low power CMOS proprietary technology
- Zero propagation delay, zero ground bounce
- Undershoot clamp diodes on all switch and control inputs
- TTL-compatible control inputs
- Available in SOIC and QSOP packages

APPLICATIONS:

- Hot-swapping, hot-docking
- Voltage translation (5V to 3.3V)
- Power conservation
- Capacitance reduction and isolation
- Logic replacement (data processing)
- Clock gating
- Bus switching and isolation

DESCRIPTION:

The QS3245 provides a set of eight high-speed CMOS TTL-compatible bus switches in a pinout compatible with 74FCT245, 74F245, 74ALS/AS/LS245 8-bit transceivers. The low ON resistance of the QS3245 allows inputs to be connected to outputs without adding propagation delay and without generating additional ground bounce noise. The Output Enable (\overline{OE}) signal turns the switches on similar to the \overline{OE} signal of the 74'245.

QuickSwitch devices provide an order of magnitude faster speed than conventional logic devices.

The QS3245 is characterized for operation at -40°C to +85°C.

FUNCTIONAL BLOCK DIAGRAM

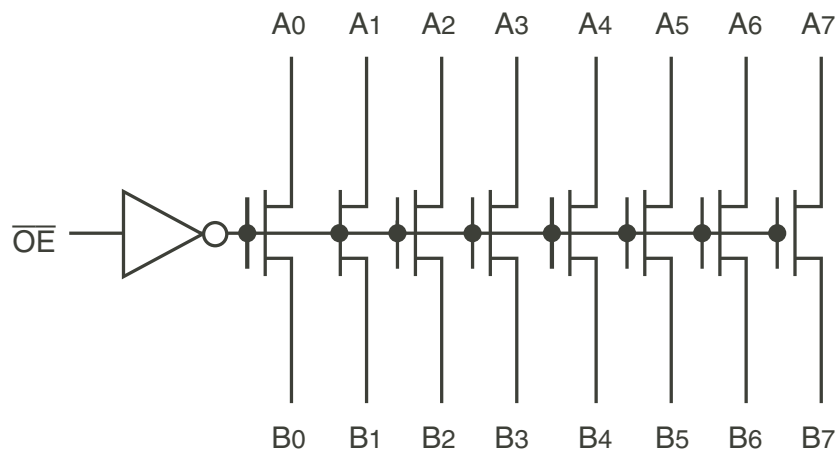

PIN CONFIGURATION

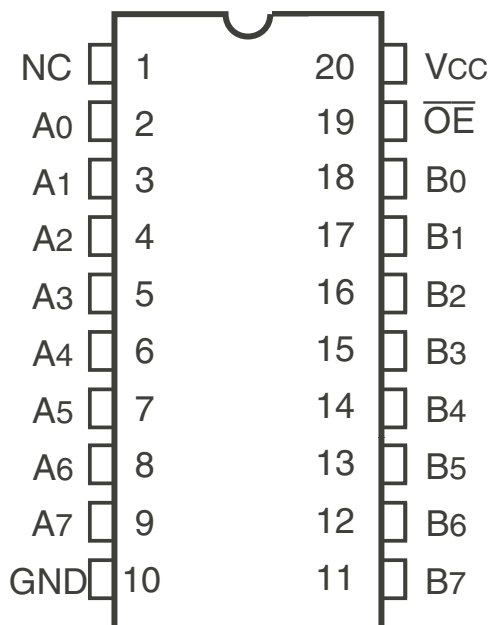

SOIC/ QSOP
TOP VIEW

ABSOLUTE MAXIMUM RATINGS⁽¹⁾

Symbol	Description	Max	Unit
VTERM ⁽²⁾	Supply Voltage to Ground	-0.5 to +7	V
VTERM ⁽³⁾	DC Switch Voltage V _s	-0.5 to +7	V
VTERM ⁽³⁾	DC Input Voltage V _{IN}	-0.5 to +7	V
VAC	AC Input Voltage (pulse width ≤ 20ns)	-3	V
IOUT	DC Output Current	120	mA
P _{MAX}	Maximum Power Dissipation (T _A = 85°C)	0.5	W
T _{STG}	Storage Temperature	-65 to +150	°C

NOTE:

- Stresses greater than those listed under ABSOLUTE MAXIMUM RATINGS may cause permanent damage to the device. This is a stress rating only and functional operation of the device at these or any other conditions above those indicated in the operational sections of this specification is not implied. Exposure to absolute maximum rating conditions for extended periods may affect reliability.
- V_{CC} terminals.
- All terminals except V_{CC}.

CAPACITANCE

(T_A = +25°C, f = 1.0MHz, V_{IN} = 0V, V_{OUT} = 0V)

Pins	Typ.	Max. ⁽¹⁾	Unit
Control Pins	3	5	pF
Quickswitch Channels (Switch OFF)	5	7	pF

NOTE:

- This parameter is measured at characterization but not tested.

PIN DESCRIPTION

Pin Names	Description
\overline{OE}	Output Enable
A _x	Data I/Os
B _x	Data I/Os

FUNCTION TABLE⁽¹⁾

\overline{OE}	Outputs
H	Disconnected
L	A _x = B _x

NOTE:

- H = HIGH Voltage Level
L = LOW Voltage Level

DC ELECTRICAL CHARACTERISTICS OVER OPERATING RANGE

Following Conditions Apply Unless Otherwise Specified:

Industrial: $T_A = -40^{\circ}\text{C}$ to $+85^{\circ}\text{C}$, $V_{CC} = 5.0\text{V} \pm 5\%$

Symbol	Parameter	Test Conditions	Min.	Typ. ⁽¹⁾	Max.	Unit
V_{IH}	Input HIGH Level	Guaranteed Logic HIGH for Control Pins	2	—	—	V
V_{IL}	Input LOW Level	Guaranteed Logic LOW for Control Pins	—	—	0.8	V
I_{IN}	Input Leakage Current (Control Inputs)	$0\text{V} \leq V_{IN} \leq V_{CC}$	—	—	± 1	μA
I_{OZ}	Off-State Output Current (Hi-Z)	$0\text{V} \leq V_{OUT} \leq V_{CC}$, Switches OFF	—	± 0.001	± 1	μA
RON	Switch ON Resistance	$V_{CC} = \text{Min.}$, $V_{IN} = 0\text{V}$, $I_{ON} = 30\text{mA}$	—	5	7	Ω
		$V_{CC} = \text{Min.}$, $V_{IN} = 2.4\text{V}$, $I_{ON} = 15\text{mA}$	—	10	15	
VP	Pass Voltage ⁽²⁾	$V_{IN} = V_{CC} = 5\text{V}$, $I_{OUT} = -5\mu\text{A}$	3.7	4	4.2	V

NOTES:

1. Typical values are at $V_{CC} = 5.0\text{V}$, $T_A = 25^{\circ}\text{C}$.
2. Pass Voltage is guaranteed but not production tested.

TYPICAL ON RESISTANCE VS V_{IN} AT $V_{CC} = 5\text{V}$

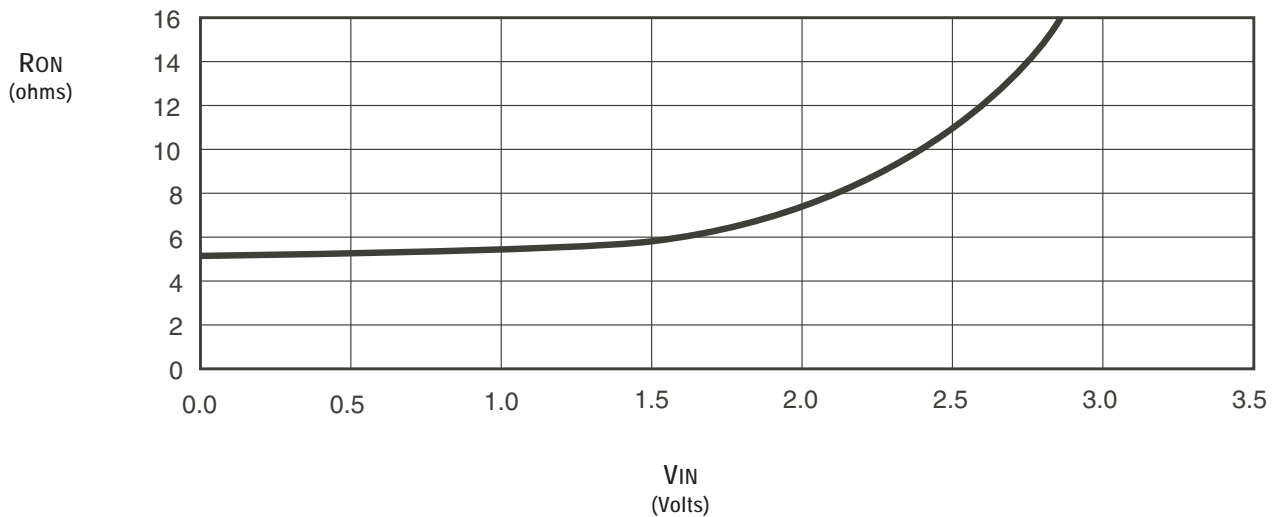

POWER SUPPLY CHARACTERISTICS

Symbol	Parameter	Test Conditions ⁽¹⁾	Max.	Unit
I _{CCQ}	Quiescent Power Supply Current	V _{CC} = Max., V _{IN} = GND or V _{CC} , f = 0	3	μA
ΔI _{CC}	Power Supply Current per Control Input HIGH ⁽²⁾	V _{CC} = Max., V _{IN} = 3.4V, f = 0	1.5	mA
I _{CCD}	Dynamic Power Supply Current per MHz ⁽³⁾	V _{CC} = Max., A and B pins open Control Inputs Toggling at 50% Duty Cycle	0.25	mA/MHz

NOTES:

- For conditions shown as Min. or Max., use the appropriate values specified under DC Electrical Characteristics.
- Per TLL driven input (V_{IN} = 3.4V, control inputs only). A and B pins do not contribute to ΔI_{CC}.
- This current applies to the control inputs only and represents the current required to switch internal capacitance at the specified frequency. The A and B inputs generate no significant AC or DC currents as they transition. This parameter is guaranteed but not production tested.

SWITCHING CHARACTERISTICS OVER OPERATING RANGE

T_A = -40°C to +85°C, V_{CC} = 5.0V ± 5%;

C_{LOAD} = 50pF, R_{LOAD} = 500Ω unless otherwise noted.

Symbol	Parameter	Min. ⁽¹⁾	Typ.	Max.	Unit
t _{PLH}	Data Propagation Delay ^(2,3)	—	—	0.25	ns
t _{PHL}	A _n to/from B _n				
t _{PZL}	Switch Turn-on Delay	0.5	—	5.6	ns
t _{PZH}	\overline{OE} to A _x /B _x				
t _{PLZ}	Switch Turn-off Delay ⁽²⁾	0.5	—	4.5	ns
t _{PHZ}	\overline{OE} to A _x /B _x				

NOTES:

- Minimums are guaranteed but not production tested.
- This parameter is guaranteed but not production tested.
- The bus switch contributes no propagation delay other than the RC delay of the ON resistance of the switch and the load capacitance. The time constant for the switch alone is of the order of 0.25ns for C_L = 50pF. Since this time constant is much smaller than the rise and fall times of typical driving signals, it adds very little propagation delay to the system. Propagation delay of the bus switch, when used in a system, is determined by the driving circuit on the driving side of the switch and its interaction with the load on the driven side.

ORDERING INFORMATION

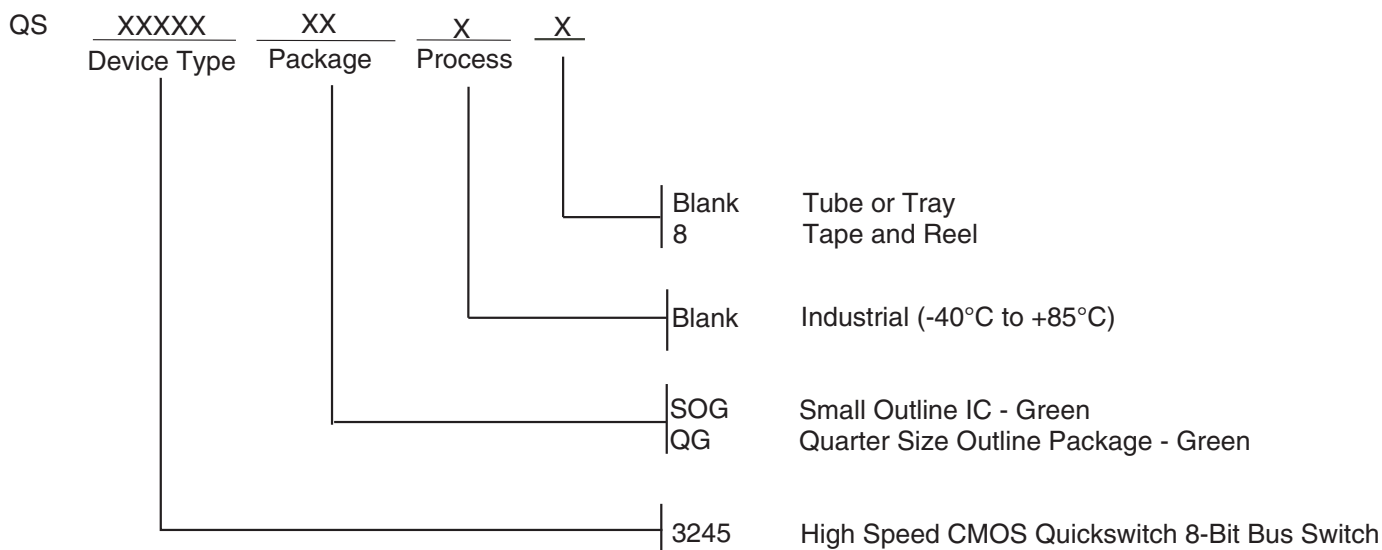

Datasheet Document History

02/14/2011	Pg. 5	Updated the ordering information by removing the "IDT" notation, non RoHS part and by adding Tape and Reel information.
11/24/2014	Pg. 1	Corrected Functional Block Diagram adding missing dot on A1.



CORPORATE HEADQUARTERS
6024 Silver Creek Valley Road
San Jose, CA 95138

for SALES:
800-345-7015 or 408-284-8200
fax: 408-284-2775
www.idt.com

for Tech Support:
logichelp@idt.com



Стандарт Электрон Связь

Мы молодая и активно развивающаяся компания в области поставок электронных компонентов. Мы поставляем электронные компоненты отечественного и импортного производства напрямую от производителей и с крупнейших складов мира.

Благодаря сотрудничеству с мировыми поставщиками мы осуществляем комплексные и плановые поставки широчайшего спектра электронных компонентов.

Собственная эффективная логистика и склад в обеспечивает надежную поставку продукции в точно указанные сроки по всей России.

Мы осуществляем техническую поддержку нашим клиентам и предпродажную проверку качества продукции. На все поставляемые продукты мы предоставляем гарантию .

Осуществляем поставки продукции под контролем ВП МО РФ на предприятия военно-промышленного комплекса России , а также работаем в рамках 275 ФЗ с открытием отдельных счетов в уполномоченном банке. Система менеджмента качества компании соответствует требованиям ГОСТ ISO 9001.

Минимальные сроки поставки, гибкие цены, неограниченный ассортимент и индивидуальный подход к клиентам являются основой для выстраивания долгосрочного и эффективного сотрудничества с предприятиями радиоэлектронной промышленности, предприятиями ВПК и научно-исследовательскими институтами России.

С нами вы становитесь еще успешнее!

Наши контакты:

Телефон: +7 812 627 14 35

Электронная почта: sales@st-electron.ru

Адрес: 198099, Санкт-Петербург,
Промышленная ул, дом № 19, литера Н,
помещение 100-Н Офис 331