

4 x 50 W class-D digital input power amplifier with I²C diagnostics, digital impedance meter (DIM) and low voltage operation

Data brief

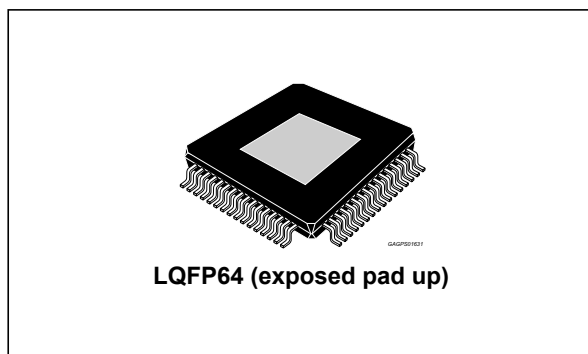

- Clipping detector
- ESD protection
- 6 V operation (“Start - Stop” engines compatibility)
- 2 and 1 Ω load driving capability

Description

FDA801B is a new BCD technology quad BRIDGE class D amplifier, specially intended for automotive applications.

Thanks to the technology used, it is possible to integrate a high performance D/A converter together with powerful MOSFET outputs in class D, to get an outstanding efficiency compared with the standard class AB.

The integrated D/A converter allows to reach outstanding performances (110 dB S/N ratio with 108 dB of dynamic range). The feedback loop includes the output L-C low-pass filter, allowing superior frequency response linearity and lower distortion independently from the inductor and capacitor quality.

FDA801B is fully configurable through I²C bus interface and integrates a full diagnostics array specially intended for automotive applications. Thanks to the solutions implemented to contain EMI emissions, the device is intended to be used in the standard single DIN car-radio box together with the tuner.

Moreover FDA801B is able to work with power supply as low as 6 V, thus supporting the most recent low voltage ('start-stop') car-makers specification.

Features

- Integrated 110 dB D/A conversion
- I²S and TDM digital input (3.3/1.8 V)
- Input sampling frequency: 44.1 kHz, 48 kHz, 96 kHz, 192 kHz
- Class-D channels with 93% efficiency
- EMI control for AM compatibility
- EMI compliance evaluated following normative IEC61967-4 and IEC62132-4
- Low radiation function (LRF)
- Idle tones free DAC
- Output lowpass filter included in the feedback allowing lower cost filter components
- Max. output power
 - 4 x 50 W/4 Ω @ 15.2 V, 1 kHz
- High output power capability
 - 28 W/4 Ω 10 % THD, V_d = 14.4 V
- Full I²C bus driving (3.3/1.8 V):
 - Channels independent tristate
 - Channel independent soft play/mute
 - I²C bus diagnostics , including DC and AC load detection and load value recognition (DIM)
- Integrated fault protection
- Input and output offset detector

Table 1. Device summary

| Order code | Package | Packing |
|-------------|----------------------|-------------|
| FDA801B-VYY | LQFP64 (exp. pad up) | Tray |
| FDA801B-VYT | LQFP64 (exp. pad up) | Tape & Reel |

Contents

- 1 Block diagram and pins description 3**
- 2 General introduction 7**
- 3 Package information 8**
 - 3.1 LQFP64 (10x10x1.4 mm exp. pad up) package information 8
- 4 Revision history 10**

1 Block diagram and pins description

Figure 1. Block diagram

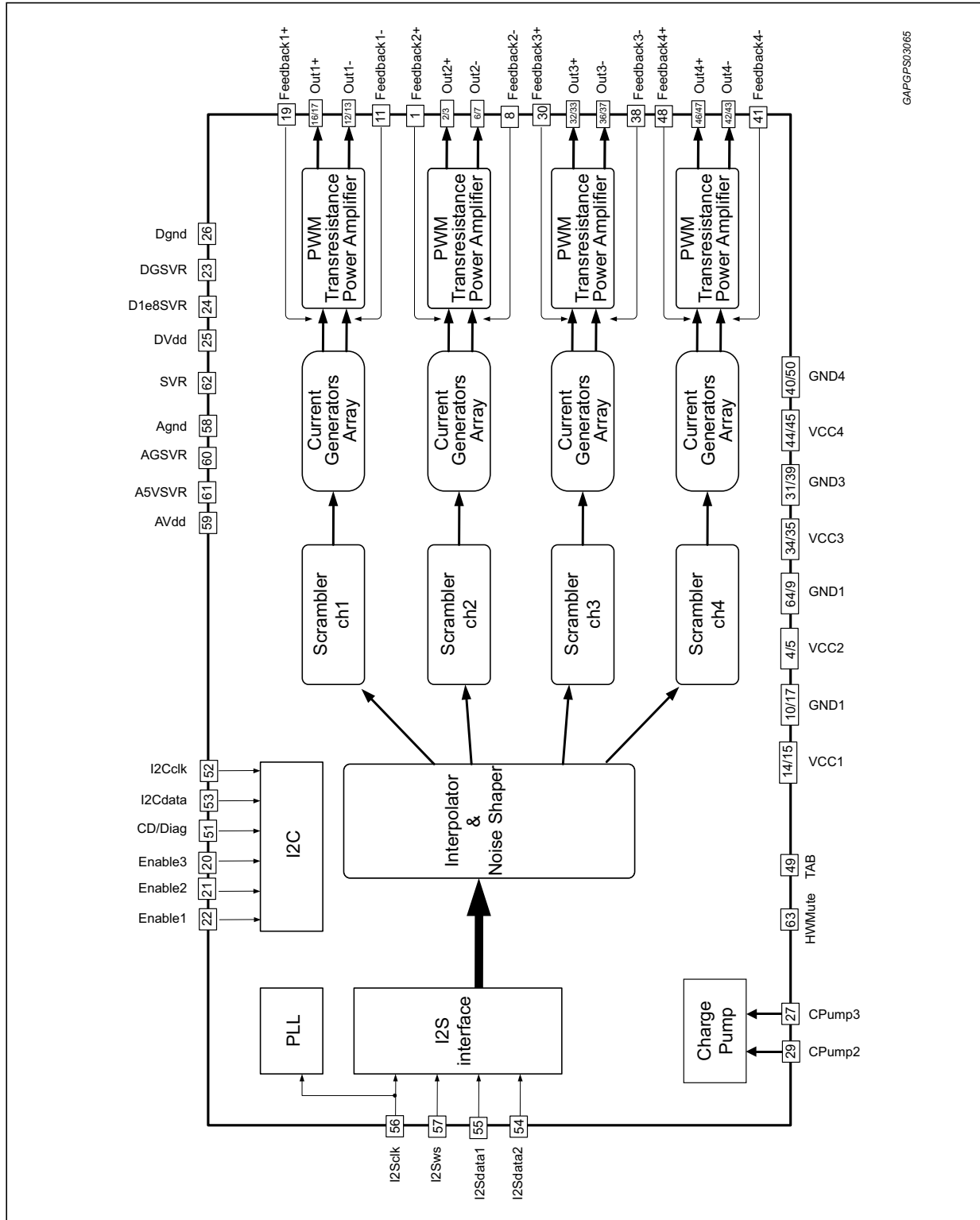
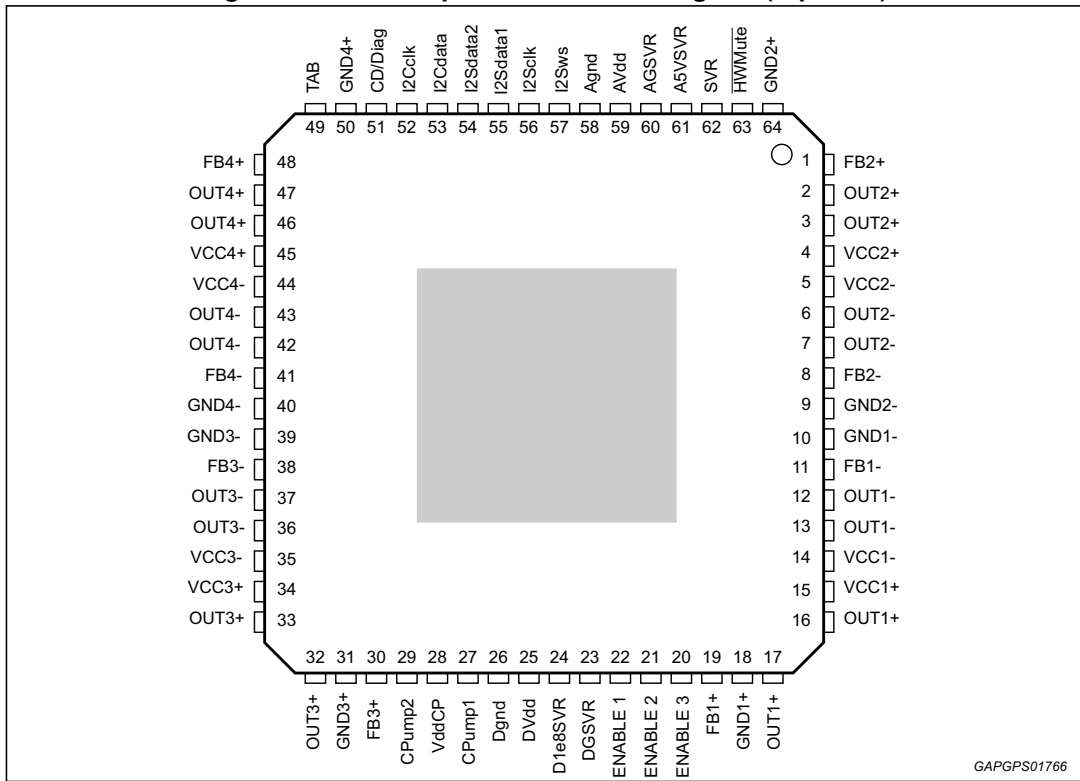

Figure 2. Tentative pins connection diagram (top view)



GAPGPS01766

Table 2. Pins list description

| N# | Pin | Function |
|----|-------|--|
| 1 | FB2+ | Channel 2, half bridge plus, Feedback |
| 2 | OUT2+ | Channel 2, half bridge plus, Output |
| 3 | OUT2+ | Channel 2, half bridge plus, Output |
| 4 | VCC2+ | Channel 2, half bridge plus, Power Supply |
| 5 | VCC2- | Channel 2, half bridge minus, Power Supply |
| 6 | OUT2- | Channel 2, half bridge minus, Output |
| 7 | OUT2- | Channel 2, half bridge minus, Output |
| 8 | FB2- | Channel 2, half bridge minus, Feedback |
| 9 | GND2- | Channel 2, half bridge minus, Power Ground |
| 10 | GND1- | Channel 1, half bridge minus, Power Ground |
| 11 | FB1- | Channel 1, half bridge minus, Feedback |
| 12 | OUT1- | Channel 1, half bridge minus, Output |
| 13 | OUT1- | Channel 1, half bridge minus, Output |
| 14 | VCC1- | Channel 1, half bridge minus, Power Supply |
| 15 | VCC1+ | Channel 1, half bridge plus, Power Supply |
| 16 | OUT1+ | Channel 1, half bridge plus, Output |

Table 2. Pins list description (continued)

| N# | Pin | Function |
|----|----------|--|
| 17 | OUT1+ | Channel 1, half bridge plus, Output |
| 18 | GND1+ | Channel 1, half bridge plus, Power Ground |
| 19 | FB1+ | Channel 1, half bridge plus, Feedback |
| 20 | ENABLE 3 | Enable 3 |
| 21 | ENABLE 2 | Enable 2 |
| 22 | ENABLE 1 | Enable 1 |
| 23 | DGSVR | Negative digital supply V(SVR)-0.9V (Internally generated) |
| 24 | D1e8SVR | Positive digital supply V(SVR)+0.9V (Internally generated) |
| 25 | DVdd | Digital supply |
| 26 | Dgnd | Digital ground |
| 27 | CPump1 | Charge Pump pin1 |
| 28 | VddCP | Charge Pump output voltage |
| 29 | CPump2 | Charge Pump pin2 |
| 30 | FB3+ | Channel 3, half bridge plus, Feedback |
| 31 | GND3+ | Channel 3, half bridge plus, Power Ground |
| 32 | OUT3+ | Channel 3, half bridge plus, Output |
| 33 | OUT3+ | Channel 3, half bridge plus, Output |
| 34 | VCC3+ | Channel 3, half bridge plus, Power Supply |
| 35 | VCC3- | Channel 3, half bridge minus, Power Supply |
| 36 | OUT3- | Channel 3, half bridge minus, Output |
| 37 | OUT3- | Channel 3, half bridge minus, Output |
| 38 | FB3- | Channel 3, half bridge minus, Feedback |
| 39 | GND3- | Channel 3, half bridge minus, Power Ground |
| 40 | GND4- | Channel 4, half bridge minus, Power Ground |
| 41 | FB4- | Channel 4, half bridge minus, Feedback |
| 42 | OUT4- | Channel 4, half bridge minus, Output |
| 43 | OUT4- | Channel 4, half bridge minus, Output |
| 44 | VCC4- | Channel 4, half bridge minus, Power Supply |
| 45 | VCC4+ | Channel 4, half bridge plus, Power Supply |
| 46 | OUT4+ | Channel 4, half bridge plus, Output |
| 47 | OUT4+ | Channel 4, half bridge plus, Output |
| 48 | FB4+ | Channel 4, half bridge plus, Feedback |
| 49 | TAB | Device slug connection |
| 50 | GND4+ | Channel 4, half bridge plus, Power Ground |

Table 2. Pins list description (continued)

| N# | Pin | Function |
|----|----------------------------|--|
| 51 | CD/Diag | Clipping detector and diagnostic output pin: – Overcurrent protection intervention – Thermal warning – Offset detection |
| 52 | I2Cclk | I2C Clock |
| 53 | I2Cdata | I2C Data |
| 54 | I2Sdata2 | I2S/TDM Data input 2 |
| 55 | I2Sdata1 | I2S/TDM Data input 1 |
| 56 | I2Sclk | I2S/TDM Clock input |
| 57 | I2Sws | I2S/TDM Sinc input |
| 58 | Agnd | Analog ground |
| 59 | AVdd | Analog supply |
| 60 | AGSVR | Negative Analog Supply V(SVR)-2.5V (Internally generated) |
| 61 | A5VSVR | Positive Analog Supply V(SVR)+2.5V (Internally generated) |
| 62 | SVR | Supply Voltage Ripple Rejection Capacitor |
| 63 | $\overline{\text{HWMute}}$ | Hardware mute pin |
| 64 | GND2+ | Channel 2, half bridge plus, Power Ground |

2 General introduction

FDA801B is a fully digital single chip class D amplifier with high immunity to the demodulation filter effects. The high integration level and the on-board signal processing allow excellent audio performance to be achieved.

Thanks to the digital input and to the feedback strategy in the power stage that make the amplifier immune from the output filter components non-linearity, the number and size of the external components are minimized.

A number of features are included to reduce EMI and the fully digital approach provides a strong GSM immunity.

FDA801B includes: digital I²C and I²S interfaces, internal 24 bits DAC conversion, digital signal processing for interpolation and noise shaping, innovative self-diagnostic functions and automatic detection of wrong load connections or variation of the load, internal PLL for a clock generation. Moreover FDA801B provides a breakthrough innovative digital impedance-meter which is able to communicate via I²C the output load value.

3 Package information

In order to meet environmental requirements, ST offers these devices in different grades of ECOPACK® packages, depending on their level of environmental compliance. ECOPACK® specifications, grade definitions and product status are available at: www.st.com.

ECOPACK® is an ST trademark.

3.1 LQFP64 (10x10x1.4 mm exp. pad up) package information

Figure 3. LQFP64 (10x10x1.4 mm exp. pad up) package outline

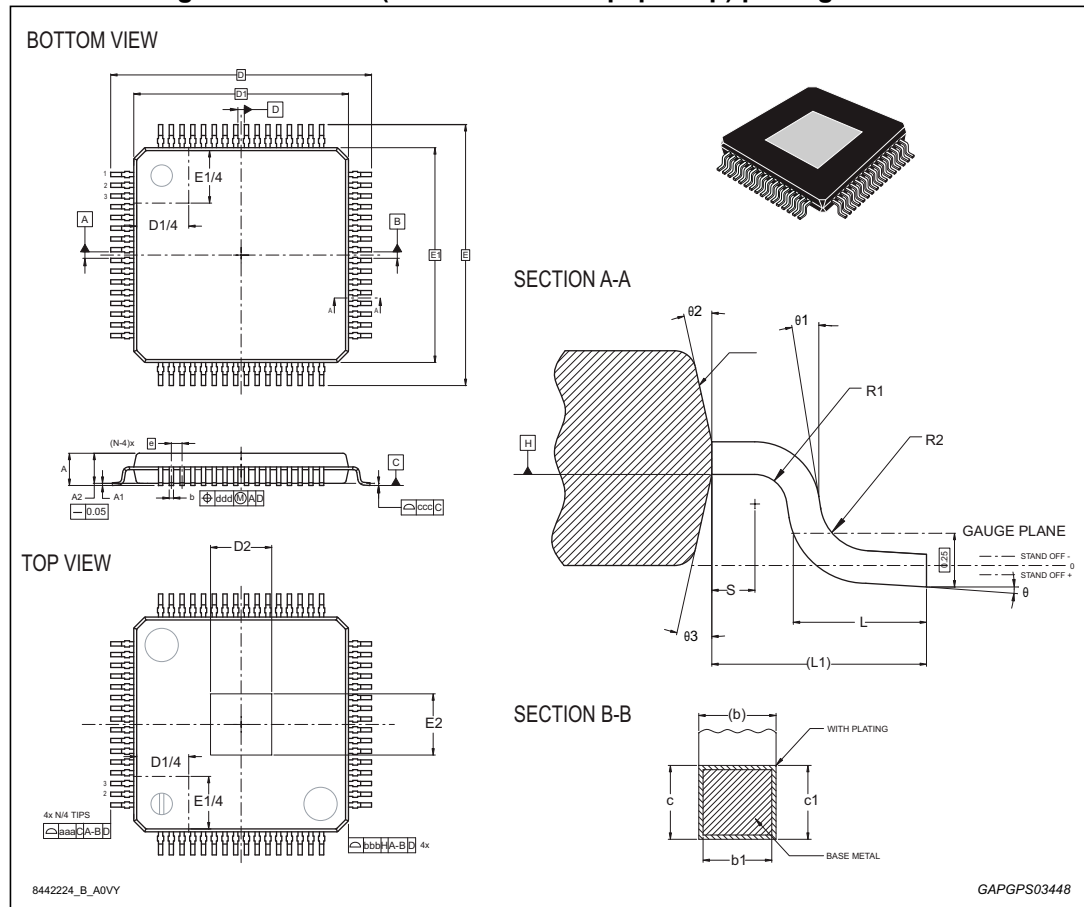

Table 3. LQFP64 (10x10x1.4 mm exp. pad up) package mechanical data

| Ref | Dimensions | | | | | |
|-------------------|-------------|-------|-------|-----------------------|--------|--------|
| | Millimeters | | | Inches ⁽¹⁾ | | |
| | Min. | Typ. | Max. | Min. | Typ. | Max. |
| Θ | 0° | 3.5° | 6° | 0° | 3.5° | 6° |
| Θ1 | 0° | 9° | 12° | 0° | 9° | 12° |
| Θ2 | 11° | 12° | 13° | 11° | 12° | 13° |
| Θ3 | 11° | 12° | 13° | 11° | 12° | 13° |
| A | - | - | 1.49 | - | - | 0.0587 |
| A1 | -0.04 | - | 0.04 | -0.0016 | - | 0.0016 |
| A2 | 1.35 | 1.4 | 1.45 | 0.0531 | 0.0551 | 0.0571 |
| b | - | - | 0.255 | - | - | 0.0100 |
| b1 | 0.17 | 0.20 | 0.23 | 0.0067 | 0.0079 | 0.0091 |
| c | 0.09 | - | 0.20 | 0.0035 | - | 0.0079 |
| c1 | 0.09 | - | 0.16 | 0.0035 | - | 0.0063 |
| D | - | 12.00 | - | - | 0.4724 | - |
| D1 ⁽²⁾ | - | 10.00 | - | - | 0.3937 | - |
| D2 ⁽³⁾ | - | 6.00 | - | - | 0.2362 | - |
| e | - | 0.50 | - | - | 0.0197 | - |
| E | - | 12.00 | - | - | 0.4724 | - |
| E1 ⁽²⁾ | - | 10.00 | - | - | 0.3937 | - |
| E2 ⁽³⁾ | - | 6.00 | - | - | 0.2362 | - |
| L | 0.45 | 0.60 | 0.75 | 0.0177 | 0.0236 | 0.0295 |
| L1 | - | 1.00 | - | - | 0.0394 | - |
| N | - | 64.00 | - | - | 2.5197 | - |
| R1 | 0.08 | - | - | 0.0031 | - | - |
| R2 | 0.08 | - | 0.20 | 0.0031 | - | 0.0079 |
| S | 0.20 | - | - | 0.0079 | - | - |
| aaa | - | 0.20 | - | - | 0.0079 | - |
| bbb | - | 0.20 | - | - | 0.0079 | - |
| ccc | - | 0.08 | - | - | 0.0031 | - |
| ddd | - | 0.08 | - | - | 0.0031 | - |

1. Values in inches are converted from mm and rounded to 4 decimal digits.
2. Dimensions D1 and E1 do not include mold flash or protrusions. Allowable mold flash or protrusion is "0.25 mm" per side.
3. The optional exposed pad is generally coincident with the top or bottom side of the package and not allowed to protrude beyond that surface.

4 Revision history

Table 4. Document revision history

| Date | Revision | Changes |
|-------------|----------|------------------|
| 13-Nov-2015 | 1 | Initial release. |

IMPORTANT NOTICE – PLEASE READ CAREFULLY

STMicroelectronics NV and its subsidiaries (“ST”) reserve the right to make changes, corrections, enhancements, modifications, and improvements to ST products and/or to this document at any time without notice. Purchasers should obtain the latest relevant information on ST products before placing orders. ST products are sold pursuant to ST’s terms and conditions of sale in place at the time of order acknowledgement.

Purchasers are solely responsible for the choice, selection, and use of ST products and ST assumes no liability for application assistance or the design of Purchasers’ products.

No license, express or implied, to any intellectual property right is granted by ST herein.

Resale of ST products with provisions different from the information set forth herein shall void any warranty granted by ST for such product.

ST and the ST logo are trademarks of ST. All other product or service names are the property of their respective owners.

Information in this document supersedes and replaces information previously supplied in any prior versions of this document.

© 2015 STMicroelectronics – All rights reserved





**Стандарт
Электрон
Связь**

Мы молодая и активно развивающаяся компания в области поставок электронных компонентов. Мы поставляем электронные компоненты отечественного и импортного производства напрямую от производителей и с крупнейших складов мира.

Благодаря сотрудничеству с мировыми поставщиками мы осуществляем комплексные и плановые поставки широчайшего спектра электронных компонентов.

Собственная эффективная логистика и склад в обеспечивает надежную поставку продукции в точно указанные сроки по всей России.

Мы осуществляем техническую поддержку нашим клиентам и предпродажную проверку качества продукции. На все поставляемые продукты мы предоставляем гарантию .

Осуществляем поставки продукции под контролем ВП МО РФ на предприятия военно-промышленного комплекса России , а также работаем в рамках 275 ФЗ с открытием отдельных счетов в уполномоченном банке. Система менеджмента качества компании соответствует требованиям ГОСТ ISO 9001.

Минимальные сроки поставки, гибкие цены, неограниченный ассортимент и индивидуальный подход к клиентам являются основой для выстраивания долгосрочного и эффективного сотрудничества с предприятиями радиоэлектронной промышленности, предприятиями ВПК и научно-исследовательскими институтами России.

С нами вы становитесь еще успешнее!

Наши контакты:

Телефон: +7 812 627 14 35

Электронная почта: sales@st-electron.ru

Адрес: 198099, Санкт-Петербург,
Промышленная ул, дом № 19, литера Н,
помещение 100-Н Офис 331