Mobile Multimedia CODEC with 1W Speaker Driver

DESCRIPTION

The WM8983 is a low power, high quality stereo CODEC designed for portable multimedia applications. Highly flexible analogue mixing functions enable new application features, combining hi-fi quality audio with voice communication.

The device integrates preamps for stereo differential mics, and includes drivers for speaker, headphone and differential or stereo line output. External component requirements are reduced as no separate microphone or headphone amplifiers are required.

Advanced on-chip digital signal processing includes a 5-band equaliser, a mixed signal Automatic Level Control for the microphone or line input through the ADC as well as a purely digital limiter function for record or playback. A programmable high pass filter in the ADC path is provided for wind noise reduction and an IIR with programmable coefficients can be used as a notch filter to suppress fixed-frequency noise.

The WM8983 digital audio interface can operate in master or slave mode, while an integrated PLL supports flexible clocking schemes. A-law and μ -law companding are fully supported.

The WM8983 operates at analogue supply voltages from 2.5V to 3.3V, although the digital core can operate at voltages down to 1.71V to save power. Speaker supplies can operate up to 5V for increased speaker output power. Additional power management control enables individual sections of the chip to be powered down under software control.

FEATURES

Stereo CODEC:

- DAC SNR 98dB, THD -84dB ('A' weighted @ 48kHz)
- ADC SNR 95dB, THD -84dB ('A' weighted @ 48kHz)
- Speaker driver (1W into 8 Ω BTL with 5V supply)
 - SNR 90dB
 - PSRR 80dB
- Headphone driver with 'capless' option
 - 40mW/channel output power into 16 Ω / 3.3V AVDD2
- Pop and click suppression

Mic Preamps:

- Stereo Differential or mono microphone Interfaces
- Programmable preamp gain
- Pseudo differential inputs with common mode rejection
- Programmable ALC / Noise Gate in ADC path
- Low-noise bias supplied for electret microphones

Other Features:

- Enhanced 3-D function for improved stereo separation
- Highly flexible mixing functions
- 5-band equaliser (ADC or DAC path)
- ADC Programmable high pass filter (wind noise reduction)
- ADC Programmable IIR notch filter
- Aux inputs for stereo analog input signals or 'beep'
- PLL supporting various clocks between 8MHz-50MHz
- Sample rates supported (kHz): 8, 11.025, 16, 12, 16, 22.05, 24, 32, 44.1, 48
- 2.5V to 3.6V analogue supplies
- 1.71V to 3.6V digital supplies
- 2.5V to 5.5V speaker supplies
- 5x5mm 32-lead QFN package

APPLICATIONS

- Multimedia mobile phones

BLOCK DIAGRAM

TABLE OF CONTENTS

DESCRIPTION	1
FEATURES	1
APPLICATIONS	1
BLOCK DIAGRAM	2
TABLE OF CONTENTS	3
PIN CONFIGURATION	5
ORDERING INFORMATION	5
PIN DESCRIPTION	6
ABSOLUTE MAXIMUM RATINGS	7
RECOMMENDED OPERATING CONDITIONS	7
ELECTRICAL CHARACTERISTICS	8
TERMINOLOGY	14
TYPICAL PERFORMANCE	15
SPEAKER OUTPUT THD VERSUS POWER.....	15
TYPICAL POWER CONSUMPTION	17
AUDIO PATHS OVERVIEW	18
SIGNAL TIMING REQUIREMENTS	19
SYSTEM CLOCK TIMING	19
AUDIO INTERFACE TIMING – MASTER MODE	19
AUDIO INTERFACE TIMING – SLAVE MODE.....	20
CONTROL INTERFACE TIMING – 3-WIRE MODE.....	21
CONTROL INTERFACE TIMING – 2-WIRE MODE.....	22
INTERNAL POWER ON RESET CIRCUIT	23
RECOMMENDED CONTROL SEQUENCES	25
POWER UP/DOWN SEQUENCE.....	25
LOUT1/ROUT1 ENABLE SEQUENCE	28
DEVICE DESCRIPTION	29
INTRODUCTION.....	29
INPUT SIGNAL PATH.....	31
ANALOGUE TO DIGITAL CONVERTER (ADC).....	40
INPUT LIMITER / AUTOMATIC LEVEL CONTROL (ALC)	44
OUTPUT SIGNAL PATH	57
ANALOGUE OUTPUTS	64
DIGITAL AUDIO INTERFACES.....	82
AUDIO SAMPLE RATES.....	87
MASTER CLOCK AND PHASE LOCKED LOOP (PLL)	87
COMPANDING.....	90
GENERAL PURPOSE INPUT/OUTPUT	92
OUTPUT SWITCHING (JACK DETECT).....	93
CONTROL INTERFACE.....	94
RESETTING THE CHIP	95
POWER SUPPLIES	95
POWER MANAGEMENT	96
REGISTER MAP	97
REGISTER BITS BY ADDRESS	99
DIGITAL FILTER CHARACTERISTICS	118
TERMINOLOGY.....	118
DAC FILTER RESPONSES	119

ADC FILTER RESPONSES	119
HIGHPASS FILTER.....	120
5-BAND EQUALISER.....	121
APPLICATIONS INFORMATION	125
RECOMMENDED EXTERNAL COMPONENTS.....	125
PACKAGE DIAGRAM	126
PACKAGE DIAGRAM FOR DEVICES MARKED KF3 / LK8 / RFD.....	126
PACKAGE DIAGRAM FOR DEVICES MARKED CT8.....	127
IMPORTANT NOTICE	128
REVISION HISTORY	129

PIN CONFIGURATION

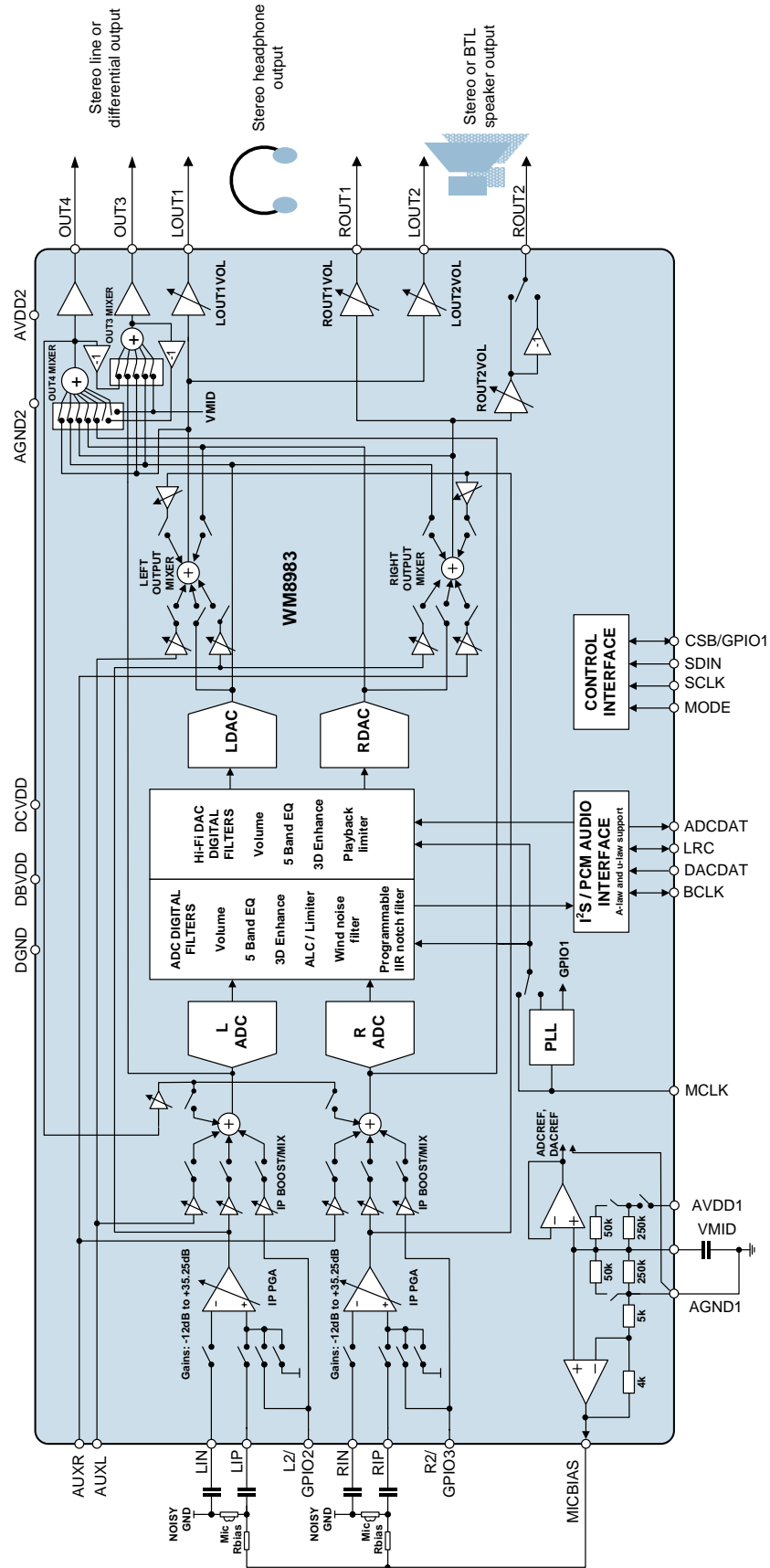
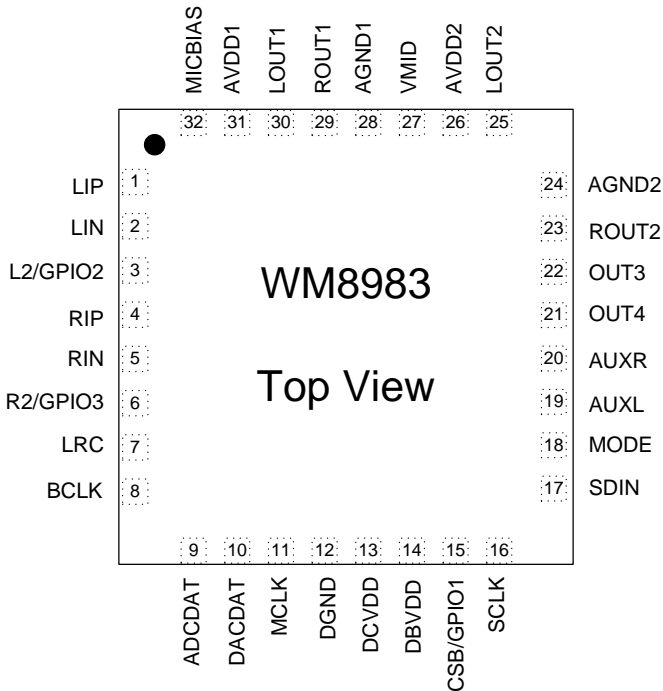
ORDERING INFORMATION

ORDER CODE	TEMPERATURE RANGE	PACKAGE	MOISTURE SENSITIVITY LEVEL	PEAK SOLDERING TEMPERATURE
WM8983GEFL/V	-25°C to +85°C	32-lead QFN (5 x 5 mm) (pb-free)	MSL3	260°C
WM8983GEFL/RV	-25°C to +85°C	32-lead QFN (5 x 5 mm) (pb-free, tape and reel)	MSL3	260°C

Note:

Reel quantity = 3,500

PIN DESCRIPTION

PIN	NAME	TYPE	DESCRIPTION
1	LIP	Analogue input	Left MIC pre-amp positive input
2	LIN	Analogue input	Left MIC pre-amp negative input
3	L2/GPIO2	Analogue input	Left channel line input/secondary mic pre-amp positive input/GPIO2 pin
4	RIP	Analogue input	Right MIC pre-amp positive input
5	RIN	Analogue input	Right MIC pre-amp negative input
6	R2/GPIO3	Analogue input	Right channel line input/secondary mic pre-amp positive input/GPIO3 pin
7	LRC	Digital Input / Output	DAC and ADC sample rate clock
8	BCLK	Digital Input / Output	Digital audio bit clock
9	ADCDAT	Digital Output	ADC digital audio data output
10	DACDAT	Digital Input	DAC digital audio data input
11	MCLK	Digital Input	Master clock input
12	DGND	Supply	Digital ground
13	DCVDD	Supply	Digital core logic supply
14	DBVDD	Supply	Digital buffer (I/O) supply
15	CSB/GPIO1	Digital Input / Output	3-Wire control interface chip Select / GPIO1 pin
16	SCLK	Digital Input	3-Wire control interface clock input / 2-wire control interface clock input
17	SDIN	Digital Input / Output	3-Wire control interface data input / 2-Wire control interface data input
18	MODE	Digital Input	Control interface selection
19	AUXL	Analogue input	Left auxiliary input
20	AUXR	Analogue input	Right auxiliary input
21	OUT4	Analogue Output	right line output or mono mix output
22	OUT3	Analogue Output	mono or left line output
23	ROUT2	Analogue Output	Headphone or line output right 2
24	AGND2	Supply	Analogue ground (feeds ROUT2/LOUT2 and OUT3/OUT4)
25	LOUT2	Analogue Output	Headphone or line output left 2
26	AVDD2	Supply	Analogue supply (feeds output amplifiers ROUT2/LOUT2 and OUT3/OUT4)
27	VMID	Reference	Decoupling for ADC and DAC reference voltage
28	AGND1	Supply	Analogue ground (feeds all input amplifiers, PLL, ADC and DAC, internal bias circuits, output amplifiers LOUT1, ROUT1)
29	ROUT1	Analogue Output	Headphone or line output right 1
30	LOUT1	Analogue Output	Headphone or line output left 1
31	AVDD1	Supply	Analogue supply (feeds all input amplifiers, PLL, ADC and DAC, internal bias circuits, output amplifiers LOUT1, LOUT2))
32	MICBIAS	Analogue Output	Microphone bias

Note:

It is recommended that the QFN ground paddle should be connected to analogue ground on the application PCB. Refer to the application note WAN_0118 on “Guidelines on How to Use QFN Packages and Create Associated PCB Footprints”

ABSOLUTE MAXIMUM RATINGS

Absolute Maximum Ratings are stress ratings only. Permanent damage to the device may be caused by continuously operating at or beyond these limits. Device functional operating limits and guaranteed performance specifications are given under Electrical Characteristics at the test conditions specified.



ESD Sensitive Device. This device is manufactured on a CMOS process. It is therefore generically susceptible to damage from excessive static voltages. Proper ESD precautions must be taken during handling and storage of this device.

Cirrus tests its package types according to IPC/JEDEC J-STD-020 for Moisture Sensitivity to determine acceptable storage conditions prior to surface mount assembly. These levels are:

MSL1 = unlimited floor life at <30°C / 85% Relative Humidity. Not normally stored in moisture barrier bag.

MSL2 = out of bag storage for 1 year at <30°C / 60% Relative Humidity. Supplied in moisture barrier bag.

MSL3 = out of bag storage for 168 hours at <30°C / 60% Relative Humidity. Supplied in moisture barrier bag.

The Moisture Sensitivity Level for each package type is specified in Ordering Information.

CONDITION	MIN	MAX
DBVDD, DCVDD, AVDD1 supply voltages	-0.3V	+4.5V
AVDD2 supply voltage	-0.3V	+7V
Voltage range digital inputs	DGND - 0.3V	DVDD + 0.3V
Voltage range analogue inputs	AGND1 - 0.3V AGND2 - 0.3V	AVDD1 + 0.3V AVDD2 + 0.3V
Storage temperature prior to soldering	30°C max / 85% RH max	
Storage temperature after soldering	-65°C	+150°C

Notes:

1. Analogue and digital grounds must always be within 0.3V of each other.
2. All digital and analogue supplies are completely independent from each other.
3. Analogue supply voltages should not be less than digital supply voltages.
4. In non-boosted mode AVDD2 should be \geq AVDD1. In boost mode, AVDD2 should be $\geq 1.5 \times$ AVDD1.
5. DBVDD must be greater than or equal to DCVDD.

RECOMMENDED OPERATING CONDITIONS

PARAMETER	SYMBOL	TEST CONDITIONS	MIN	TYP	MAX	UNIT
Digital supply range (Core)	DCVDD		1.71		3.6	V
Digital supply range (Buffer)	DBVDD		1.71 ²		3.6	V
Analogue supply range	AVDD1		2.5		3.6	V
Speaker supply range	AVDD2		2.5		5.5	V
Ground	DGND, AGND1, AGND2			0		V

Notes:

1. Analogue supply voltages should not be less than digital supply voltages.
2. DBVDD should be $\geq 1.9V$ when using the PLL.

ELECTRICAL CHARACTERISTICS
Test Conditions

 DCVDD=1.8V, AVDD1=AVDD2=DBVDD=3.3V, T_A = +25°C, 1kHz signal, fs = 48kHz, 24-bit audio data unless otherwise stated.

PARAMETER	SYMBOL	TEST CONDITIONS	MIN	TYP	MAX	UNIT
Microphone Input PGA Inputs (LIP, LIN, RIP, RIN, L2, R2)						
INPPGAVOLL, INPPGAVOLR, PGABOOSTL and PGABOOSTR = 0dB						
Full-scale Input Signal Level – Single-ended input via LIN/RIN ¹				AVDD/3.3		V _{rms}
Full-scale Input Signal Level – Pseudo-differential input ^{1,2}				AVDD*0.7/ 3.3		V _{rms}
Input PGA equivalent input noise		INPPGAVOLL/R = +35.25dB No input signal 22Hz to 20kHz		150		μV
LIN, RIN input resistance		INPPGAVOLL and INPPGAVOLR = +35.25dB		1.7		kΩ
LIN, RIN input resistance		INPPGAVOLL and INPPGAVOLR = 0dB		47		kΩ
LIN, RIN input resistance		INPPGAVOLL and INPPGAVOLR = -12dB		76		kΩ
LIP, RIP input resistance		All gain settings		95		kΩ
L2, R2 input resistance		L2_2INPPGA and R2_2INPPGA = 1 L2_2BOOSTVOL and R2_2BOOSTVOL = 000		90		kΩ
L2, R2 input resistance		L2_2INPPGA and R2_2INPPGA = 0 L2_2BOOSTVOL and R2_2BOOSTVOL = +6dB		11		kΩ
L2, R2 input resistance		L2_2INPPGA and R2_2INPPGA = 0 L2_2BOOSTVOL and R2_2BOOSTVOL = 0dB		22		kΩ
L2, R2 input resistance		L2_2INPPGA and R2_2INPPGA = 0 L2_2BOOSTVOL and R2_2BOOSTVOL = -12dB		60		kΩ
Input Capacitance		All analogue input pins		10		pF
Input PGA Programmable Gain		Gain adjusted by INPPGAVOLL and INPPGAVOLR	-12		+35.25	dB
Programmable Gain Step Size		Guaranteed monotonic		0.75		dB
Input PGA Mute Attenuation		INPPGAMUTEL and INPPGAMUTER = 1		100		dB
Input Gain Boost		PGABOOSTL and PGABOOSTR = 0		0		dB
Input Gain Boost		PGABOOSTL and PGABOOSTR = 1		+20		dB

Test Conditions

DCVDD=1.8V, AVDD1=AVDD2=DBVDD=3.3V, T_A = +25°C, 1kHz signal, fs = 48kHz, 24-bit audio data unless otherwise stated.

PARAMETER	SYMBOL	TEST CONDITIONS	MIN	TYP	MAX	UNIT
Auxiliary Analogue Inputs (AUXL, AUXR)						
Full-scale Input Signal Level ²				AVDD/3.3		V _{rms}
Input Resistance		Left Input boost and mixer enabled, at +6dB		4.3		kΩ
		Left Input boost and mixer enabled, at 0dB gain		8.6		kΩ
		Left Input boost and mixer enabled, at -12dB gain		39.1		kΩ
		Right Input boost, mixer enabled, at +6dB gain		3		kΩ
		Right Input boost, mixer enabled, at 0dB gain		6		kΩ
		Right Input boost, mixer enabled, at -12dB gain		29		kΩ
Input Capacitance		All analogue Inputs		10		pF
Gain range from AUXL and AUXR input to left and right input PGA mixers		Gain adjusted by AUXL2BOOSTVOL and AUXR2BOOSTVOL	-12		+6	dB
AUXLBOOSTVOL and AUXRBOOSTVOL step size				3		dB
L2, R2 Line Input Programmable Gain						
Gain range from L2/R2 input to left and right input PGA mixers		Gain adjusted by L2_2BOOSTVOL and R2_2BOOSTVOL	-12		+6	dB
L2/R2_2BOOSTVOL step size				3		dB
L2/R2_2BOOSTVOL mute attenuation				100		dB
OUT4 to left or right input boost record path						
Gain range into left and right input PGA mixers		Gain adjusted by OUT4_2ADCVOL	-6		+12	dB
OUT4_2ADCVOL gain step size				3		dB
OUT4_2ADCVOL mute attenuation				100		dB
Analogue to Digital Converter (ADC) - Input from LIN/P and RIN/P in differential configuration to input PGA INPPGAVOLL, INPPGAVOLR, PGABOOSTL, PGABOOSTR, ADCLVOL and ADCRVOL = 0dB						
Signal to Noise Ratio ³	SNR	A-weighted AVDD1=AVDD2=3.3V		93		dB
		A-weighted AVDD1=AVDD2=2.5V		91.5		dB
Total Harmonic Distortion ⁴	THD	-12dBV Input AVDD1=AVDD2=3.3V		-78		dBFS
		-12dBV Input AVDD1=AVDD2=2.5V		-75		dBFS
Total Harmonic Distortion + Noise ⁵	THD+N	-12dBV Input AVDD1=AVDD2=3.3V		-75		dBFS
		-12dBV Input AVDD1=AVDD2=2.5V		-72		dBFS
Channel Separation ⁶		1kHz full scale input signal		100		dBFS

Test Conditions

 DCVDD=1.8V, AVDD1=AVDD2=DBVDD=3.3V, T_A = +25°C, 1kHz signal, fs = 48kHz, 24-bit audio data unless otherwise stated.

PARAMETER	SYMBOL	TEST CONDITIONS	MIN	TYP	MAX	UNIT
Analogue to Digital Converter (ADC) - Input from L2, R2 into right PGA mixer. L2_2INPPGA and R2_2INPPGA = 0. INPPGAVOLL, INPPGAVOLR, L2_2BOOSTVOL, R2_2BOOSTVOL, ADCLVOL and ADCRVOL = 0dB						
Signal to Noise Ratio ³	SNR	A-weighted AVDD1=AVDD2=3.3V		95		dB
		A-weighted AVDD1=AVDD2=2.5V		93		dB
Total Harmonic Distortion ⁴	THD	-3dBV Input AVDD1=AVDD2=3.3V		-86		dBFS
		-3dBV Input AVDD1=AVDD2=2.5V		-78		dBFS
Total Harmonic Distortion + Noise ⁵	THD+N	-3dBV Input AVDD1=AVDD2=3.3V		-80		dBFS
		-3dBV Input AVDD1=AVDD2=2.5V		-76		dBFS
Channel Separation ⁶		1kHz input signal		100		dBFS
DAC to left and right mixers into 10kΩ / 50pF load on LOUT1 and ROUT1 LOUT1VOL, ROUT1VOL, DACLVOL and DACRVOL = 0dB						
Full-scale output ¹		LOUT1VOL and ROUTVOL = 0dB		AVDD1/3.3		V _{rms}
Signal to Noise Ratio ³	SNR	A-weighted AVDD1=AVDD2=3.3V		100		dB
		A-weighted AVDD1=AVDD2=2.5V		99		dB
Total Harmonic Distortion ⁴	THD	0dBFS input AVDD1=AVDD2=3.3V		-84		dBFS
		0dBFS input AVDD1=AVDD2=2.5V		-86		dBFS
Total Harmonic Distortion + Noise ⁵	THD+N	0dBFS input AVDD1=AVDD2=3.3V		-83		dBFS
		0dBFS input AVDD1=AVDD2=2.5V		-84		dBFS
Channel Separation ⁶		1kHz signal		100		dB
DAC to L/R mixer into 10kΩ / 50pF load on L/ROUT2 LOUT2VOL, ROUT2VOL, DACLVOL and DACRVOL = 0dB						
Full-scale output ¹				AVDD1/3.3		V _{rms}
Signal to Noise Ratio ³	SNR	A-weighted AVDD1=AVDD2=3.3V		100		dB
		A-weighted AVDD1=AVDD2=2.5V		96		dB
Total Harmonic Distortion ⁴	THD	0dBFS input AVDD1=AVDD2=3.3V		-84		dBFS
		0dBFS input AVDD1=AVDD2=2.5V		-82		dBFS
Total Harmonic Distortion + Noise ⁵	THD+N	0dBFS input AVDD1=AVDD2=3.3V		-82		dBFS
		0dBFS input AVDD1=AVDD2=2.5V		-80		dBFS
Channel Separation ⁶		1kHz input signal		100		dB

Test Conditions

 DCVDD=1.8V, AVDD1=AVDD2=DBVDD=3.3V, T_A = +25°C, 1kHz signal, fs = 48kHz, 24-bit audio data unless otherwise stated.

PARAMETER	SYMBOL	TEST CONDITIONS	MIN	TYP	MAX	UNIT
DAC to OUT3 and OUT4 mixers to OUT3/OUT4 outputs into 10kΩ / 50pF load. DACLVOL and DACRVOL = 0dB						
Full-scale output voltage				AVDD2/3.3		V _{rms}
Signal to Noise Ratio ³	SNR	A-weighted AVDD1=AVDD2=3.3V		101.5		dB
Total Harmonic Distortion ⁴	THD	full-scale signal AVDD1=AVDD2=3.3V		-80		dBFS
		full-scale signal AVDD1=AVDD2=2.5V		-87		dBFS
Total Harmonic Distortion + Noise ⁵	THD+N	full-scale signal AVDD1=AVDD2=3.3V		-77		dBFS
		full-scale signal AVDD1=AVDD2=2.5V		-85		dBFS
Channel Separation ⁶		1kHz signal		100		dBFS
DAC to left and right mixer into headphone (16Ω load) on LOUT2 and ROUT2 LOUT2VOL, ROUT2VOL, DACLVOL and DACRVOL = 0dB						
Full-scale output				AVDD1/3.3		V _{rms}
Signal to Noise Ratio ³	SNR	A-weighted AVDD1=AVDD2=3.3V		98		dB
Total Harmonic Distortion ⁴	THD	P _o = 20mW, RL=16Ω		-76		dBFS
Total Harmonic Distortion + Noise ⁵	THD+N	P _o = 20mW, RL=16Ω		-72		dBFS
Channel Separation ⁶		1kHz signal		100		dB
Bypass paths to left and right output mixers. BYPL2LMIX = 1 and BYPR2RMIX = 1						
PGA gain range into mixer		Gain adjusted by BYPLMIXVOL and BYPRMIXVOL	-15	0	+6	dB
BYPLMIXVOL and BYPRMIXVOL gain step into mixer				3		dB
Mute attenuation		BYPL2LMIX = 0 BYPR2RMIX = 0		100		dB
Analogue outputs (LOUT1, ROUT1, LOUT2, ROUT2)						
Programmable Gain range		Gain adjusted by L/ROUT1VOL and L/ROUT2VOL	-57	0	+6	dB
Programmable Gain step size		Guaranteed monotonic		1		dB
Mute attenuation		1kHz, full scale signal L/ROUT1MUTE = 1 L/ROUT2MUTE = 1		85		dB

Test Conditions

DCVDD=1.8V, AVDD1=AVDD2=DBVDD=3.3V, T_A = +25°C, 1kHz signal, fs = 48kHz, 24-bit audio data unless otherwise stated.

PARAMETER	SYMBOL	TEST CONDITIONS	MIN	TYP	MAX	UNIT
LIN and RIN input PGA to input boost stage into 10kΩ / 50pF load on OUT3/OUT4 outputs						
INPPGAVOLL, INPPGAVOLR, PGABOOSTL and PGABOOSTR = 0dB						
Full-scale output voltage, 0dB gain				AVDD2/3.3		V _{rms}
Signal to Noise Ratio ³	SNR	A-weighted AVDD1=AVDD2=3.3V	90	98		dB
		A-weighted AVDD1=AVDD2=2.5V		96		dB
		22Hz to 22kHz AVDD1=AVDD2=3.3V		95.5		dBFS
		22Hz to 22kHz AVDD1=AVDD2=2.5V		93.5		dBFS
Total Harmonic Distortion ⁴	THD	full-scale signal AVDD1=AVDD2=3.3V		-84		dBFS
		full-scale signal AVDD1=AVDD2=2.5V		-82		dBFS
Total Harmonic Distortion + Noise ⁵	THD+N	full-scale signal AVDD1=AVDD2=3.3V		-82		dBFS
		full-scale signal AVDD1=AVDD2=2.5V		-80		dBFS
Channel Separation ⁶				100		dB
LIN and RIN into input PGA Bypass to LOUT1 and ROUT1 into 10kΩ / 50pF loads						
BYPLMIXVOL, BYPRMIXVOL, LOUT1VOL and ROUT1VOL = 0dB						
Full-scale output voltage, 0dB gain				AVDD1/3.3		V _{rms}
SIGNAL TO NOISE RATIO ³	SNR	A-weighted AVDD1=AVDD2=3.3V	90	100		dB
		A-weighted AVDD1=AVDD2=2.5V		96		dB
		22Hz to 22kHz AVDD1=AVDD2=3.3V		95.5		dB
		22Hz to 22kHz AVDD1=AVDD2=2.5V		93.5		dB
Total Harmonic Distortion ⁴	THD	full-scale signal AVDD1=AVDD2=3.3V		-87	-75	dBFS
		full-scale signal AVDD1=AVDD2=2.5V		-69		dBFS
Total Harmonic Distortion + Noise ⁵	THD+N	full-scale signal AVDD1=AVDD2=3.3V		-85	-73	dBFS
		full-scale signal AVDD1=AVDD2=2.5V		-68		dBFS
Channel separation ⁶		1kHz full scale signal		100		dB

Test Conditions

DCVDD=1.8V, AVDD1=AVDD2=DBVDD=3.3V, T_A = +25°C, 1kHz signal, fs = 48kHz, 24-bit audio data unless otherwise stated.

PARAMETER	SYMBOL	TEST CONDITIONS	MIN	TYP	MAX	UNIT
Speaker Output (LOUT2, ROUT2 with 8Ω bridge tied load, INVROUT2=1)						
Full scale output voltage, 0dB gain. ⁷		SPKBOOST=0		AVDD2/ 3.3		Vrms
		SPKBOOST=1		(AVDD2/ 3.3)*1.5		
Output Power	P _O	Output power is very closely correlated with THD; see below				
Total Harmonic Distortion	THD	P _O =200mW, R _L = 8Ω, AVDD2=3.3V		0.04 -68		% dB
		P _O =320mW, R _L = 8Ω, AVDD2=3.3V		1.0 -40		% dB
		P _O =500mW, R _L = 8Ω, AVDD2=5V		0.02 -74		% dB
		P _O =860mW, R _L = 8Ω, AVDD2=5V		1.0 -40		% dB
Signal to Noise Ratio	SNR	AVDD2=3.3V, R _L = 8Ω		90		dB
		AVDD2=5V, R _L = 8Ω		90		dB
Power Supply Rejection Ratio (50Hz-22kHz)	PSRR	R _L = 8Ω BTL		80		dB
		R _L = 8Ω BTL AVDD2=5V (boost)		69		dB
Microphone Bias						
Bias Voltage		MBVSEL=0		0.9 x AVDD1		V
		MBVSEL=1		0.65 x AVDD1		V
Bias Current Source		for V _{MICBIAS} within +/-3%			3	mA
Output Noise Voltage		1kHz to 20kHz		15		nV/√Hz
Digital Input / Output						
Input HIGH Level	V _{IH}		0.7 x DBVDD			V
Input LOW Level	V _{IL}				0.3 x DBVDD	V
Output HIGH Level	V _{OH}	I _{OL} =1mA	0.9 x DBVDD			V
Output LOW Level	V _{OL}	I _{OH} =1mA			0.1 x DBVDD	V
Input Capacitance		All digital pins		10		pF

TERMINOLOGY

1. Full-scale input and output levels scale in relation to AVDD or AVDD2 depending upon the input or output used. For example, when AVDD = 3.3V, 0dBFS = 1V_{rms} (0dBV). When AVDD < 3.3V the absolute level of 0dBFS will decrease with a linear relationship to AVDD.
2. Input level to RIP and LIP in differential configurations is limited to a maximum of -3dB or performance will be reduced.
3. Signal-to-noise ratio (dBFS) – SNR is the difference in level between a reference full scale output signal and the device output with no signal applied. This ratio is also called idle channel noise. (No Auto-zero or Automute function is employed in achieving these results).
4. Total Harmonic Distortion (dBFS) – THD is the difference in level between a reference full scale output signal and the first seven odd harmonics of the output signal. To calculate the ratio, the fundamental frequency of the output signal is notched out and an RMS value of the next seven harmonics is calculated.
5. Total Harmonic Distortion plus Noise (dBFS) – THD+N is the difference in level between a reference full scale output signal and the sum of the harmonics, wide-band noise and interference on the output signal. To calculate the ratio, the fundamental frequency of the output signal is notched out and an RMS value of the total harmonics, wide-band noise and interference is calculated.
6. Channel Separation (dB) – Also known as Cross-Talk. This is a measure of the amount one channel is isolated from the other. Normally measured by sending a full scale signal down one channel and measuring the other.
7. The maximum output voltage can be limited by the speaker power supply. If SPKBOOST is set, then AVDD2 should be 1.5xAVDD to prevent clipping taking place in the output stage (when PGA gains are set to 0dB).

TYPICAL PERFORMANCE

SPEAKER OUTPUT THD VERSUS POWER

Audio Precision

WM8983 THD+N vs. Output Power -- SPKVDD=3.6V

08/29/06 11:40:44

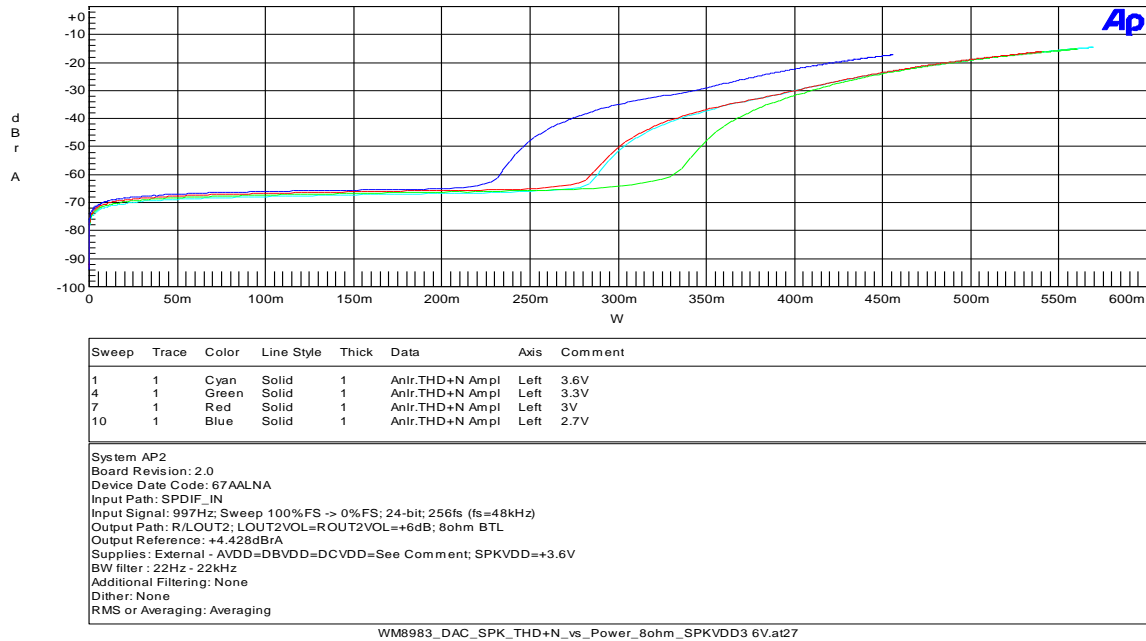

Figure 1 Speaker THD+N vs Output Power (Boost Disabled: SPKVDD=3.6V; SPKBOOST=0; AVDD Range =3.6-2.7V)

Audio Precision

WM8983 THD+N vs. Output Power -- SPKVDD=4.2V

08/29/06 12:57:21

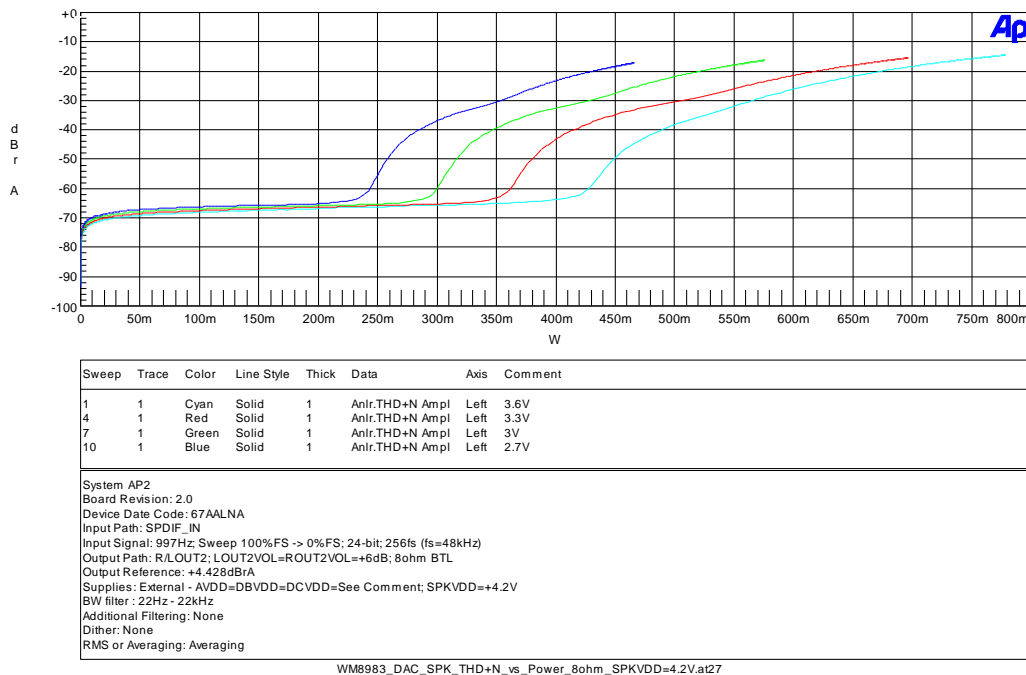

Figure 2 Speaker THD+N vs Output Power (Boost Disabled: SPKVDD=4.2V; SPKBOOST=0; AVDD Range =3.6-2.7V)

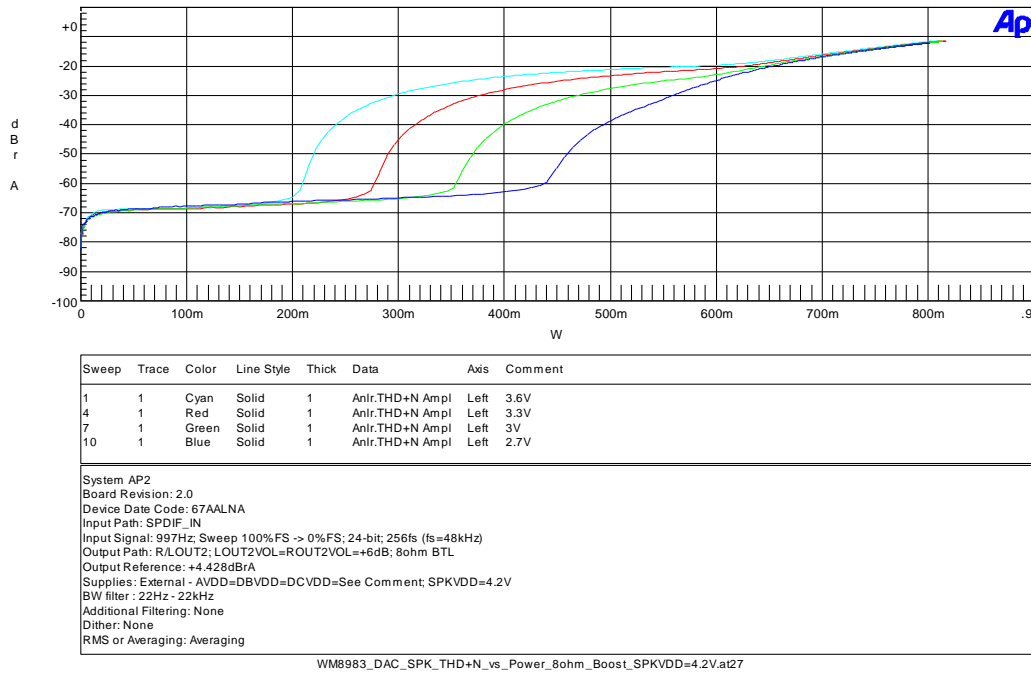

Figure 3 Speaker THD+N vs Output Power (Boost Mode: SPKVDD=4.2V; SPKBOOST=1; AVDD Range =3.6-2.7V)

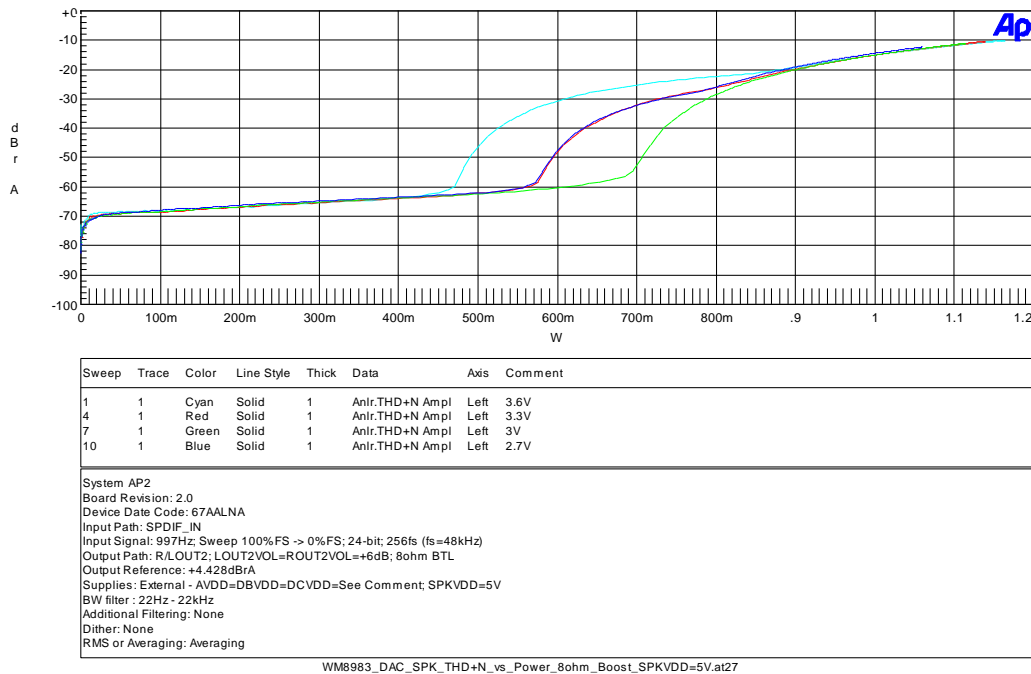

Figure 4 Speaker THD+N vs Output Power (Boost Mode: SPKVDD=5V; SPKBOOST=1; AVDD Range =3.6-2.7V)

TYPICAL POWER CONSUMPTION

Estimated current consumption for typical scenarios are shown below.

Power delivered to the load is not included.

MODE	I_{AVDD1} mA (3.3V)	I_{AVDD2} mA (3.3V)	I_{DCVDD} mA (1.8V)	I_{DBVDD} mA (1.8V)	TOTAL mW
Off (No clocks, temperature sensor disabled)	0.010	0.010	0.001	0.002	0.071
Sleep (VREF maintained)	0.100	0.001	0.012	0.003	0.360
Mono Record from Differential MIC (8kHz, PLL enabled)	4.000	0.001	0.400	0.030	13.97
Stereo HP Playback (44.1kHz, PLL enabled)	3.700	0.950	2.100	0.100	19.31

Table 1 Power Consumption

AUDIO PATHS OVERVIEW

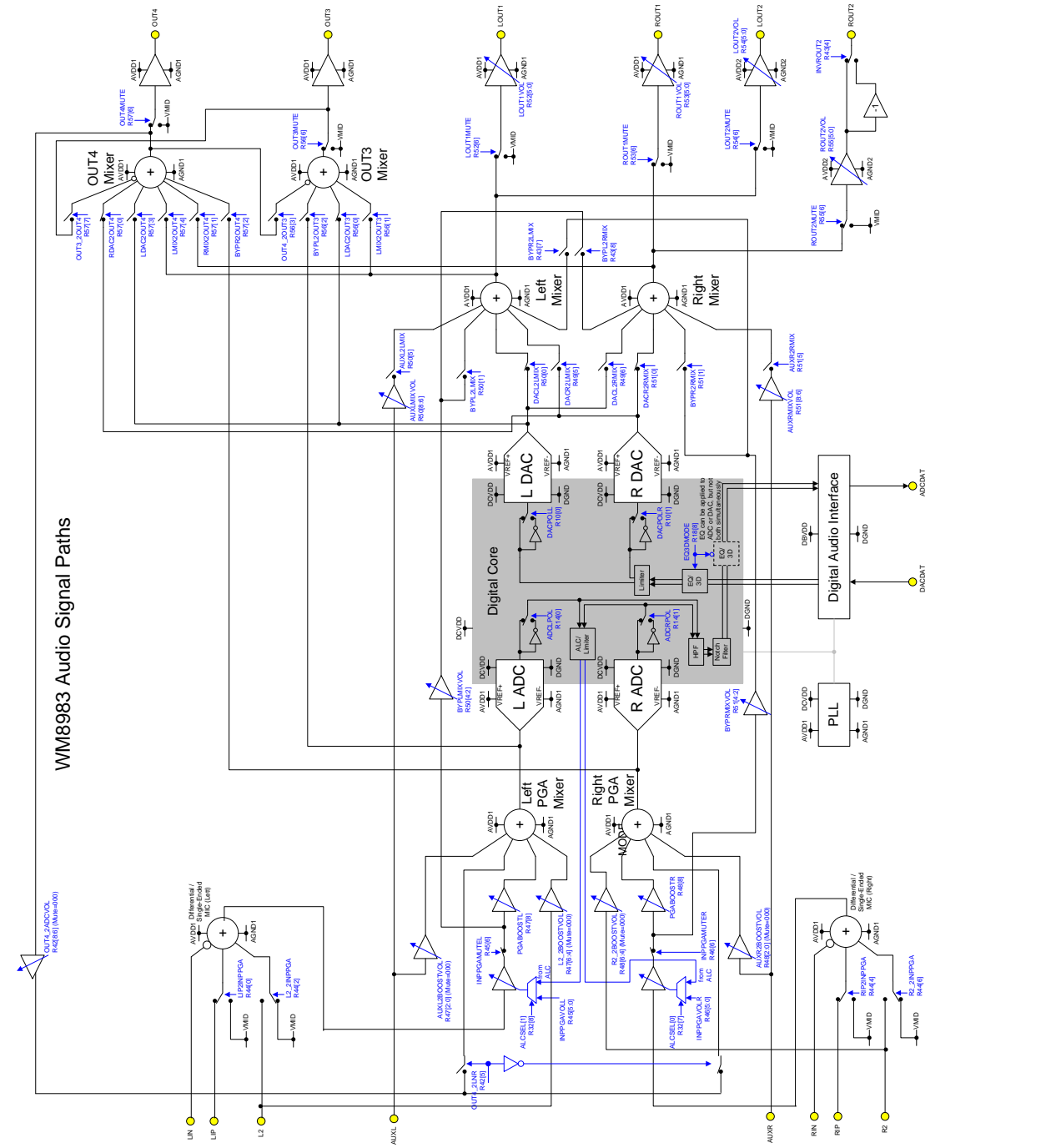

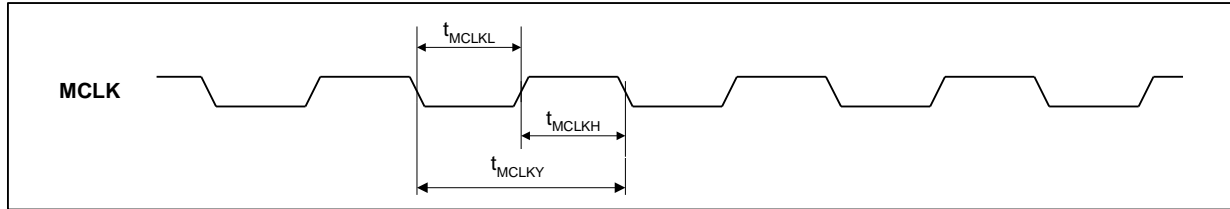
SIGNAL TIMING REQUIREMENTS
SYSTEM CLOCK TIMING

Figure 5 System Clock Timing Requirements
Test Conditions

 DCVDD=1.8V, DBVDD=AVDD1=AVDD2=3.3V, DGND=AGND1=AGND2=0V, $T_A = +25^\circ\text{C}$, Slave Mode

PARAMETER	SYMBOL	CONDITIONS	MIN	TYP	MAX	UNIT
System Clock Timing Information						
MCLK cycle time	T_{MCLKY}	MCLK=SYSCLK (=256fs)	81.38			ns
		MCLK input to PLL ^{Note 1}	20			ns
MCLK duty cycle	T_{MCLKDS}		60:40		40:60	

Note:

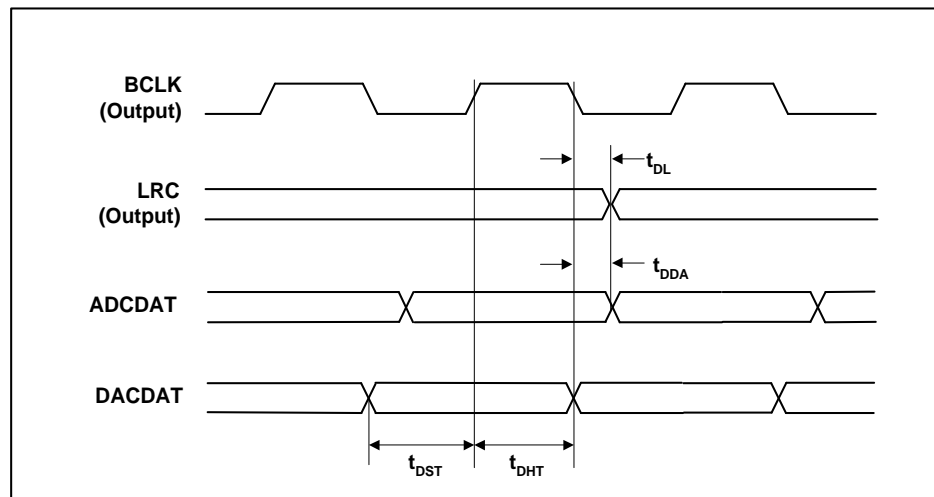
1. PLL pre-scaling and PLL N and K values should be set appropriately so that SYSCLK is no greater than 12.288MHz.

AUDIO INTERFACE TIMING – MASTER MODE

Figure 6 Digital Audio Data Timing – Master Mode (see Control Interface)
Test Conditions

 DCVDD=1.8V, DBVDD=AVDD1=AVDD2=3.3V, DGND=AGND1=AGND2=0V, $T_A = +25^\circ\text{C}$, Master Mode, $f_s = 48\text{kHz}$, MCLK=256fs, 24-bit data, unless otherwise stated.

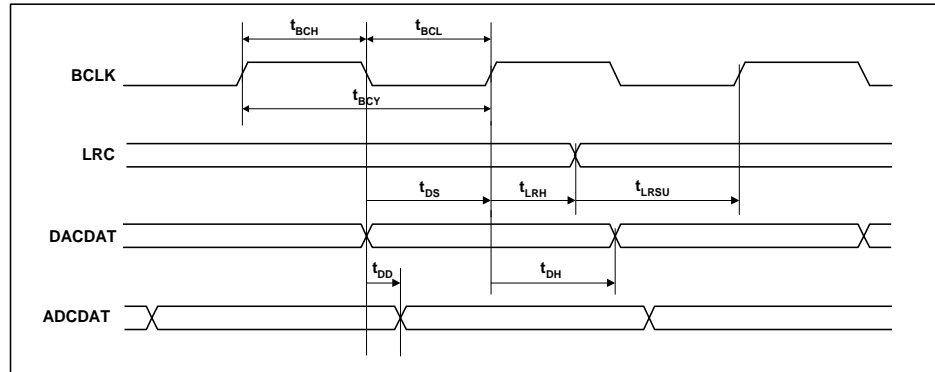
PARAMETER	SYMBOL	MIN	TYP	MAX	UNIT
Audio Data Input Timing Information					
LRC propagation delay from BCLK falling edge	t_{DL}			10	ns
ADCDAT propagation delay from BCLK falling edge	t_{DDA}			25	ns
DACDAT setup time to BCLK rising edge	t_{DST}	10			ns
DACDAT hold time from BCLK rising edge	t_{DHT}	10			ns

AUDIO INTERFACE TIMING – SLAVE MODE

Figure 7 Digital Audio Data Timing – Slave Mode
Test Conditions

DCVDD=1.8V, DBVDD=AVDD1=AVDD2=3.3V, DGND=AGND1=AGND2=0V, T_A=+25°C, Slave Mode, fs=48kHz, MCLK= 256fs, 24-bit data, unless otherwise stated.

PARAMETER	SYMBOL	MIN	TYP	MAX	UNIT
Audio Data Input Timing Information					
BCLK cycle time	t _{BCY}	50			ns
BCLK pulse width high	t _{BCH}	20			ns
BCLK pulse width low	t _{BCL}	20			ns
LRC set-up time to BCLK rising edge	t _{LRSU}	10			ns
LRC hold time from BCLK rising edge	t _{LRH}	10			ns
DACDAT hold time from BCLK rising edge	t _{DH}	10			ns
DACDAT set-up time to BCLK rising edge	t _{DS}	10			ns
ADCDAT propagation delay from BCLK falling edge	t _{DD}			25	ns

Note:

BCLK period should always be greater than or equal to MCLK period.

CONTROL INTERFACE TIMING – 3-WIRE MODE

3-wire mode is selected by connecting the MODE pin high.

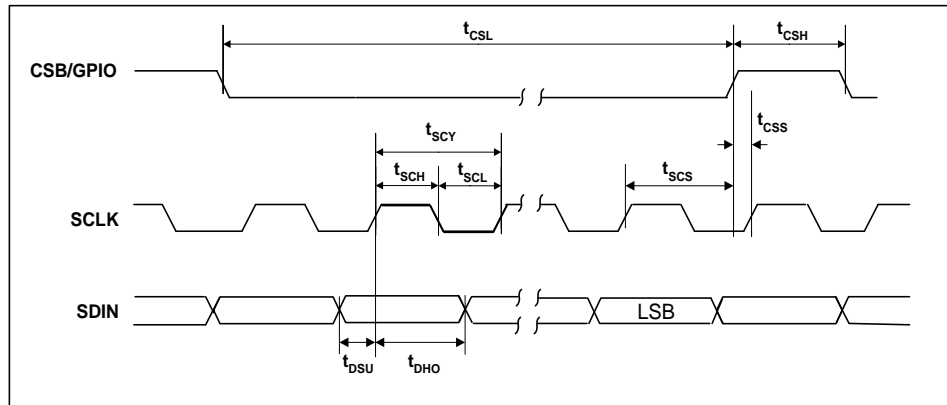

Figure 8 Control Interface Timing – 3-Wire Serial Control Mode

Test Conditions

DCVDD=1.8V, DBVDD=AVDD1=AVDD2=3.3V, DGND=AGND1=AGND2=0V, $T_A=+25^\circ\text{C}$, Slave Mode, $f_s=48\text{kHz}$, MCLK=256fs, 24-bit data, unless otherwise stated.

PARAMETER	SYMBOL	MIN	TYP	MAX	UNIT
Program Register Input Information					
SCLK rising edge to CSB rising edge	t_{SCS}	80			ns
SCLK pulse cycle time	t_{SCY}	200			ns
SCLK pulse width low	t_{SCL}	80			ns
SCLK pulse width high	t_{SCH}	80			ns
SDIN to SCLK set-up time	t_{DSU}	40			ns
SCLK to SDIN hold time	t_{DHO}	40			ns
CSB pulse width low	t_{CSL}	40			ns
CSB pulse width high	t_{CSH}	40			ns
CSB rising to SCLK rising	t_{CSS}	40			ns
Pulse width of spikes that will be suppressed	t_{ps}	0		5	ns

CONTROL INTERFACE TIMING – 2-WIRE MODE

2-wire mode is selected by connecting the MODE pin low.

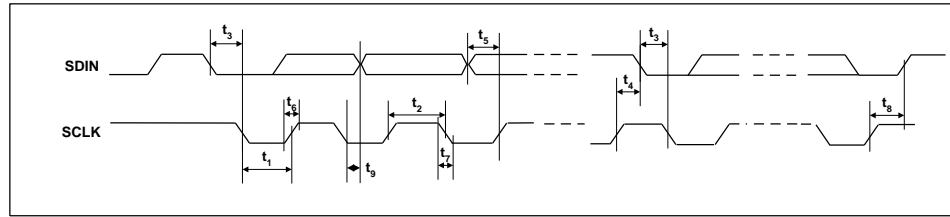
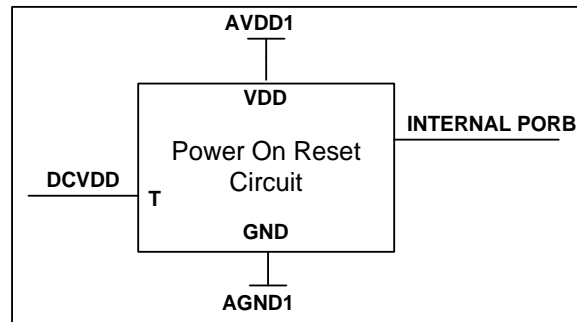

Figure 9 Control Interface Timing – 2-Wire Serial Control Mode

Test Conditions

DCVDD=1.8V, DBVDD=AVDD1=AVDD2=3.3V, DGND=AGND1=AGND2=0V, T_A=+25°C, Slave Mode, fs=48kHz, MCLK=256fs, 24-bit data, unless otherwise stated.

PARAMETER	SYMBOL	MIN	TYP	MAX	UNIT
Program Register Input Information					
SCLK Frequency		0		526	kHz
SCLK Low Pulse-Width	t ₁	1.3			us
SCLK High Pulse-Width	t ₂	600			ns
Hold Time (Start Condition)	t ₃	600			ns
Setup Time (Start Condition)	t ₄	600			ns
Data Setup Time	t ₅	100			ns
SDIN, SCLK Rise Time	t ₆			300	ns
SDIN, SCLK Fall Time	t ₇			300	ns
Setup Time (Stop Condition)	t ₈	600			ns
Data Hold Time	t ₉			900	ns
Pulse width of spikes that will be suppressed	t _{ps}	0		5	ns

INTERNAL POWER ON RESET CIRCUIT

Figure 10 Internal Power on Reset Circuit Schematic

The WM8983 includes an internal Power-On-Reset Circuit, as shown in Figure 10, which is used to reset the digital logic into a default state after power up. The POR circuit is powered from AVDD1 and monitors DCVDD. It asserts PORB low if AVDD1 or DCVDD is below a minimum threshold.

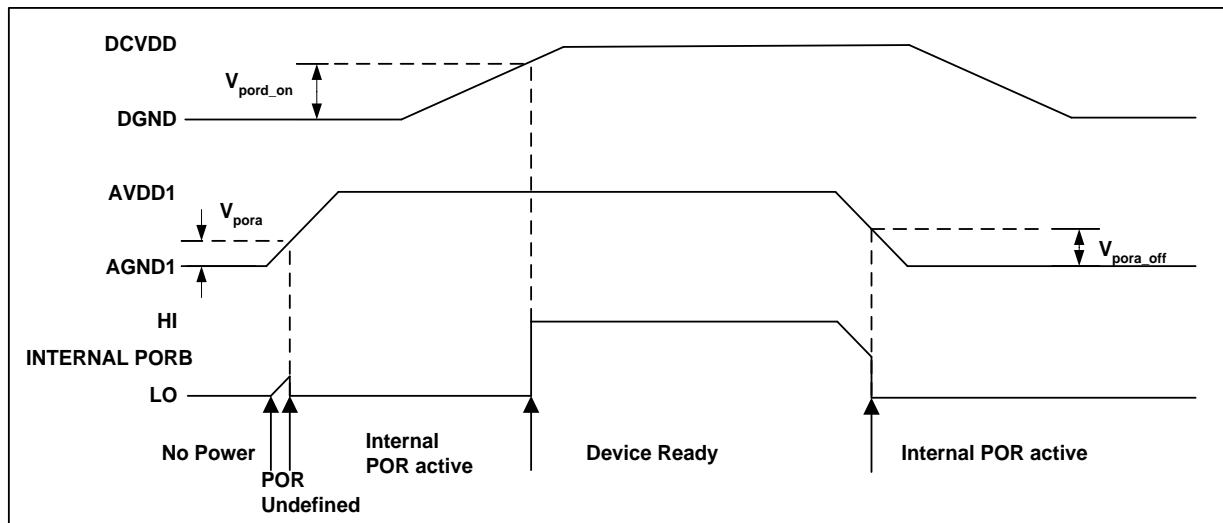

Figure 11 Typical Power up Sequence where AVDD1 is powered before DCVDD

Figure 11 shows a typical power-up sequence where AVDD1 comes up first. When AVDD1 goes above the minimum threshold, V_{pora} , there is enough voltage for the circuit to guarantee PORB is asserted low and the chip is held in reset. In this condition, all writes to the control interface are ignored. Now AVDD1 is at full supply level. Next DCVDD rises to V_{pord_on} and PORB is released high and all registers are in their default state and writes to the control interface may take place.

On power down, where AVDD1 falls first, PORB is asserted low whenever AVDD1 drops below the minimum threshold V_{pora_off} .

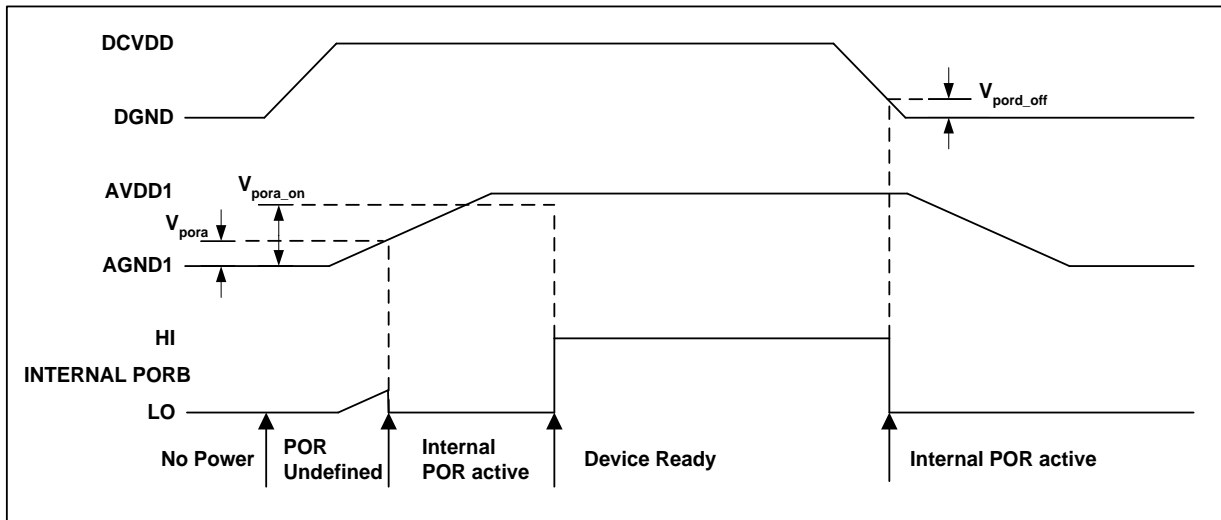

Figure 12 Typical Power up Sequence where DCVDD is Powered before AVDD1

Figure 12 shows a typical power-up sequence where DCVDD comes up first. First it is assumed that DCVDD is already up to specified operating voltage. When AVDD1 goes above the minimum threshold, V_{pora} , there is enough voltage for the circuit to guarantee PORB is asserted low and the chip is held in reset. In this condition, all writes to the control interface are ignored. When AVDD1 rises to V_{pora_on} , PORB is released high and all registers are in their default state and writes to the control interface may take place.

On power down, where DCVDD falls first, PORB is asserted low whenever DCVDD drops below the minimum threshold V_{pord_off} .

SYMBOL	MIN	TYP	MAX	UNIT
V_{pora}	0.4	0.6	0.8	V
V_{pora_on}	0.9	1.2	1.6	V
V_{pora_off}	0.4	0.6	0.8	V
V_{pord_on}	0.5	0.7	0.9	V
V_{pord_off}	0.4	0.6	0.8	V

Table 2 Typical POR Operation (Typical Simulated Values)

Notes:

1. If AVDD1 and DCVDD suffer a brown-out (i.e. drop below the minimum recommended operating level but do not go below V_{pora_off} or V_{pord_off}), then the chip will not reset and will resume normal operation when the voltage is back to the recommended level again.
2. The chip will enter reset at power down when AVDD1 or DCVDD falls below V_{pora_off} or V_{pord_off} . This may be important if the supply is turned on and off frequently by a power management system.
3. The minimum t_{por} period is maintained even if DCVDD and AVDD1 have zero rise time. This specification is guaranteed by design rather than test.

RECOMMENDED CONTROL SEQUENCES

POWER UP/DOWN SEQUENCE

In order to minimise output pop and click noise, it is recommended that the WM8983 device is powered up and down under control using the following sequences:

Power Up:

- Turn on external power supplies. Wait for supply voltage to settle.
- Set low bias mode, BIASCUT = 1.
- Mute all Outputs and set PGAs to minimum gain, R52 to R57 = 0x140h.
- Enable VMID independent current bias, POBCTRL = 1, DELEN = 1.
- Enable required outputs, DACs and mixers.
- Enable analogue bias, BIASEN, and VMID with required charge time e.g. VMIDSEL=01 = 100kΩ.
- Setup digital interface, input amplifiers, PLL, ADCs and DACs for desired operation.
- Unmute L/ROUT1 and set desired volume, e.g. for 0dB R52 and R53 = 0x139h.
- Unmute L/ROUT2 and set desired volume, e.g. for 0dB R54 and R55 = 0x139h.
- Disable VMID independent current bias, POBCTRL = 0, DELEN = 0.

Power Down:

- Disable Thermal shutdown
- Disable VMIDSEL=00 and BIASEN=0
- Wait for VMID to discharge
- Power off registers R1, R2, R3 = 0x000h
- Remove external power supplies

Note:

Charging time constant is determined by impedance selected by VMIDSEL and the value of decoupling capacitor connected to VMID pin.

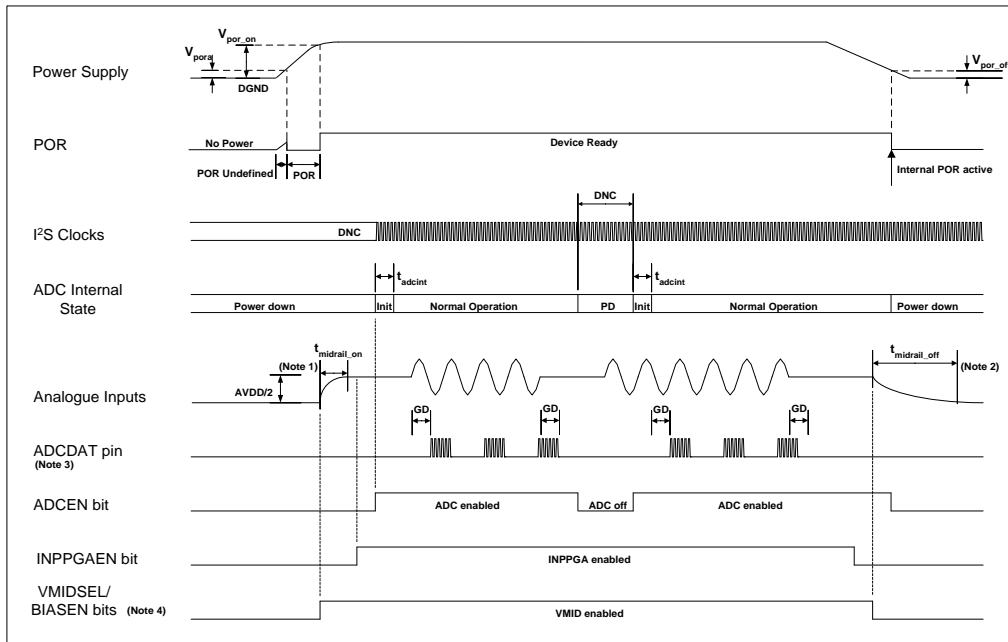

Figure 13 ADC Power Up and Down Sequence (not to scale)

SYMBOL	MIN	TYPICAL	MAX	UNIT
$t_{\text{midrail_on}}$		300		ms
$t_{\text{midrail_off}}$		>6		s
t_{adcint}		2/fs		s
ADC Group Delay		29/fs		s

Table 3 Typical POR Operation (typical simulated values)

Notes:

1. The analogue input pin charge time, $t_{\text{midrail_on}}$, is determined by the VMID pin charge time. This time is dependent upon the value of VMID decoupling capacitor and VMID pin input resistance and AVDD power supply rise time.
2. The analogue input pin discharge time, $t_{\text{midrail_off}}$, is determined by the analogue input coupling capacitor discharge time. The time, $t_{\text{midrail_off}}$, is measured using a 1 μ F capacitor on the analogue input but will vary dependent upon the value of input coupling capacitor.
3. While the ADC is enabled, there will be LSB data bit activity on the ADCDAT pin due to system noise, but no significant digital output will be present.
4. The VMIDSEL and BIASEN bits must be set to enable analogue input midrail voltage and for normal ADC operation.
5. ADCDAT data output delay from power up – with power supplies starting from 0V – is determined primarily by the VMID charge time. ADC initialisation and power management bits may be set immediately after POR is released; VMID charge time will be significantly longer and will dictate when the device is stabilised for analogue input.
6. ADCDAT data output delay at power up from device standby (power supplies already applied) is determined by ADC initialisation time, 2/fs.

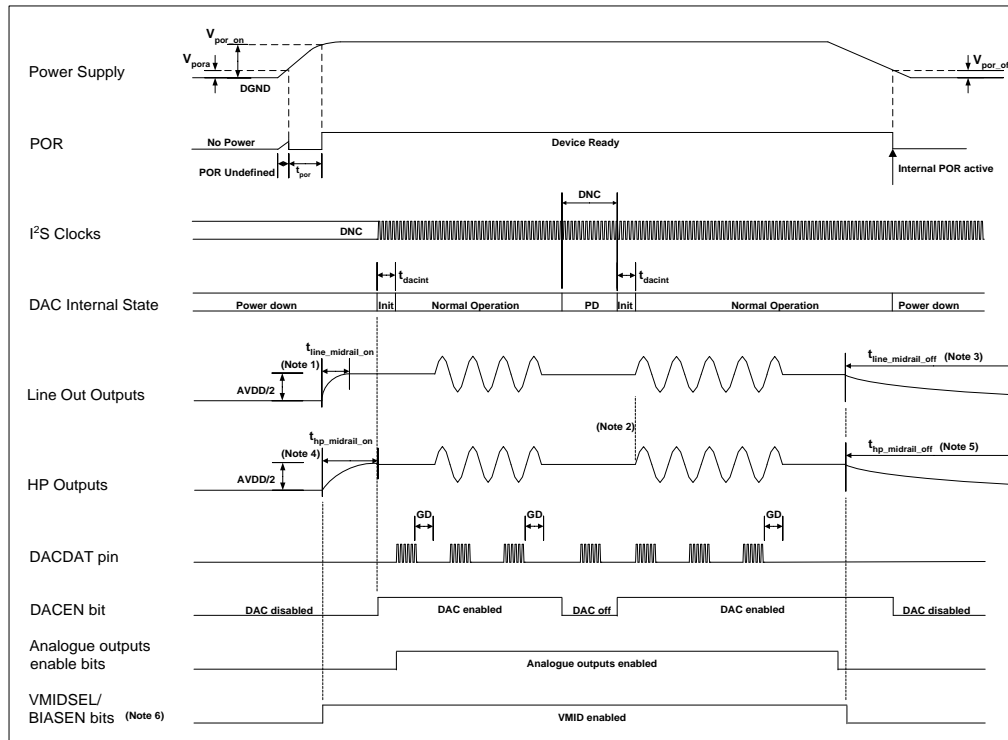
Figure 14 DAC Power Up and Down Sequence (not to scale)

SYMBOL	MIN	TYPICAL	MAX	UNIT
$t_{line_midrail_on}$		300		ms
$t_{line_midrail_off}$		>6		s
$t_{hp_midrail_on}$		300		ms
$t_{hp_midrail_off}$		>6		s
t_{dacint}		2/fs		s
DAC Group Delay		29/fs		s

Table 4 Typical POR Operation (typical simulated values)
Notes:

1. The lineout charge time, $t_{line_midrail_on}$, is determined by the VMID pin charge time. This time is dependent upon the value of VMID decoupling capacitor and VMID pin input resistance and AVDD power supply rise time. The values above were measured using a 4.7µF capacitor.
2. It is not advisable to allow DACDAT data input during initialisation of the DAC. If the DAC data value is not zero at point of initialisation, then this is likely to cause a pop noise on the analogue outputs. The same is also true if the DACDAT is removed at a non-zero value, and no mute function has been applied to the signal beforehand.
3. The lineout discharge time, $t_{line_midrail_off}$, is determined by the VMID pin discharge time. This time is dependent upon the value of VMID decoupling capacitor and VMID pin input resistance. The values above were measured using a 4.7µF capacitor.
4. The headphone charge time, $t_{hp_midrail_on}$, is dependent upon the value of VMID decoupling capacitor and VMID pin input resistance and AVDD power supply rise time. The values above were measured using a 4.7µF VMID decoupling capacitor.
5. The headphone discharge time, $t_{hp_midrail_off}$, is dependent upon the value of VMID decoupling capacitor and VMID pin input resistance. The values above were measured using a 4.7µF VMID decoupling capacitor.
6. The VMIDSEL and BIASEN bits must be set to enable analogue output midrail voltage and for normal DAC operation.

LOUT1/ROUT1 ENABLE SEQUENCE

In order to minimise click noise, it is recommended that the WM8983 headphone outputs are enabled using the following sequence:

- Activate dual enable function DELEN = 1 (R42).
- Enable L/ROUT1 amplifier core, LOUT1EN = 1, ROUT1EN = 1 (R2).
- Enable output FETs, OUT1DEL = 1 (R42).
- Disable DELEN = 0.
- Reset OUT1DEL = 0.

Notes:

All outputs on WM8983 can also be enabled with a single write to enable bits in registers 2 and 3 without click minimisation. Disabling outputs does not require click minimisation.

DEVICE DESCRIPTION

INTRODUCTION

The WM8983 is a low power audio CODEC combining a high quality stereo audio DAC and ADC, with flexible line and microphone input and output processing.

FEATURES

The chip offers great flexibility in use, and so can support many different modes of operation as follows:

MICROPHONE INPUTS

Two pairs of stereo microphone inputs are provided, allowing a pair of stereo microphones to be pseudo-differentially connected, with user defined gain. The provision of the common mode input pin for each stereo input allows for rejection of common mode noise on the microphone inputs (level depends on gain setting chosen). A microphone bias is output from the chip which can be used to bias both microphones. The signal routing can be configured to allow manual adjustment of mic levels, or to allow the ALC loop to control the level of mic signal that is transmitted.

Total gain through the microphone paths of up to +55.25dB can be selected.

PGA AND ALC OPERATION

A programmable gain amplifier is provided in the input path to the ADC. This may be used manually or in conjunction with a mixed analogue/digital automatic level control (ALC) which keeps the recording volume constant.

LINE INPUTS (AUXL, AUXR)

AUXL and AUXR, can be used as a stereo line input or as an input for warning tones (or 'beeps') etc. These inputs can be summed into the record paths, along with the microphone preamp outputs, so allowing for mixing of audio with 'backing music' etc as required.

ADC

The stereo ADC uses a 24-bit high-order oversampling architecture to deliver optimum performance with low power consumption.

HI-FI DAC

The hi-fi DAC provides high quality audio playback suitable for all portable audio hi-fi type applications, including MP3 players, portable multimedia devices and portable disc players of all types.

OUTPUT MIXERS

Flexible mixing is provided on the outputs of the device. A stereo mixer is provided for the stereo headphone or line outputs, LOUT1/ROUT1, and additional summers on the OUT3/OUT4 outputs allow for an optional differential or stereo line output on these pins. Gain adjustment PGAs are provided for the LOUT1/ROUT1 and LOUT2/ROUT2 outputs, and signal switching is provided to allow for all possible signal combinations.

OUT3 and OUT4 can be configured to provide an additional stereo or mono differential lineout from the output of the DACs, the mixers or the input microphone boost stages. They can also provide a midrail reference for pseudo differential inputs to external amplifiers.

AUDIO INTERFACES

The WM8983 has a standard audio interface to support the transmission of stereo data to and from the chip. This interface is a 3 wire standard audio interface which supports a number of audio data formats including:

- I²S
- DSP/PCM Mode (a burst mode in which LRC sync plus 2 data packed words are transmitted)
- MSB-First, left justified
- MSB-First, right justified

The interface can operate in master or slave modes.

CONTROL INTERFACES

To allow full software control over all features, the WM8983 offers a choice of 2 or 3 wire control interface. It is fully compatible and an ideal partner for a wide range of industry standard microprocessors, controllers and DSPs.

Selection of the mode is via the MODE pin. In 2 wire mode, the address of the device is fixed as 0011010.

CLOCKING SCHEMES

WM8983 offers the normal audio DAC clocking scheme operation, where 256fs MCLK is provided to the DAC and ADC.

A PLL is included which may be used to generate these clocks in the event that they are not available from the system controller. This PLL can accept a range of common input clock frequencies between 8MHz and 50MHz to generate high quality audio clocks. If this PLL is not required for generation of these clocks, it can be reconfigured to generate alternative clocks which may then be output on the GPIO pins and used elsewhere in the system.

POWER CONTROL

The design of the WM8983 has given much attention to power consumption without compromising performance. It operates at very low voltages, includes the ability to power off any unused parts of the circuitry under software control, and includes standby and power off modes.

AUXILIARY ANALOG INPUT SUPPORT

Additional stereo analog signals might be connected to the Line inputs of WM8983 (e.g. melody chip or FM radio), and the stereo signal listened to via headphones, or recorded, simultaneously if required.

INPUT SIGNAL PATH

The WM8983 has a number of flexible analogue inputs. There are two input channels, Left and Right, each of which consists of an input PGA stage followed by a boost/mix stage which drives into the hi-fi ADC. Each input path has three input pins which can be configured in a variety of ways to accommodate single-ended, differential or dual differential microphones. There are two auxiliary input pins which can be fed into to the input boost/mix stage as well as driving into the output path. A bypass path exists from the output of the boost/mix stage into the output left/right mixers.

MICROPHONE INPUTS

The WM8983 can accommodate a variety of microphone configurations including single ended and pseudo differential inputs. The inputs to the left pseudo differential input PGA are LIP and L2. The inputs to the right pseudo differential input PGA are RIP and R2. LIN and RIN are used for a.c. coupled ground inputs.

In single-ended microphone input configuration, the microphone signal should be input to LIN or RIN and the non-inverting input of the input PGA clamped to VMID.

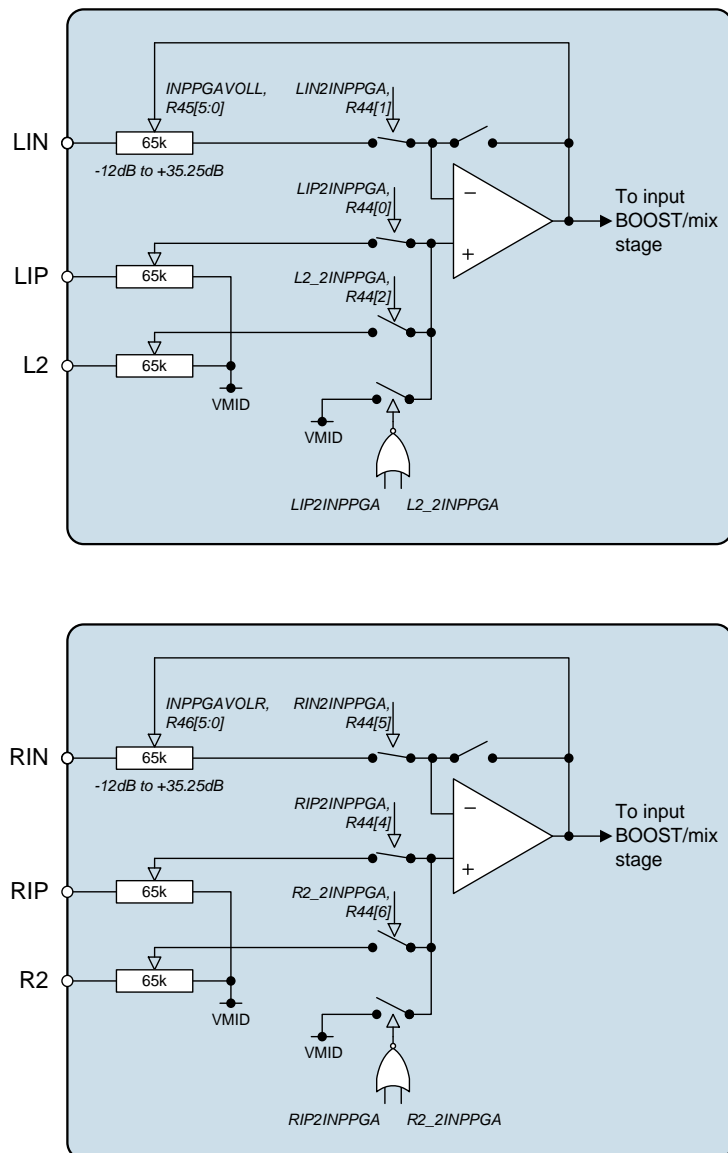

Figure 15 Microphone Input PGA Circuit

The input PGAs are enabled by the INPPGAENL and INPPGAENR register bits.

REGISTER ADDRESS	BIT	LABEL	DEFAULT	DESCRIPTION
R2 Power Management 2	2	INPPGAENL	0	Left channel input PGA enable 0 = disabled 1 = enabled
	3	INPPGAENR	0	Right channel input PGA enable 0 = disabled 1 = enabled

Table 5 Input PGA Enable Register Settings

REGISTER ADDRESS	BIT	LABEL	DEFAULT	DESCRIPTION
R44 Input Control	0	LIP2INPPGA	1	Connect LIP pin to left channel input PGA amplifier positive terminal. 0 = LIP not connected to input PGA 1 = input PGA amplifier positive terminal connected to LIP (constant input impedance)
	1	LIN2INPPGA	1	Connect LIN pin to left channel input PGA negative terminal. 0 = LIN not connected to input PGA 1 = LIN connected to input PGA amplifier negative terminal.
	2	L2_2INPPGA	0	Connect L2 pin to left channel input PGA positive terminal. 0 = L2 not connected to input PGA 1 = L2 connected to input PGA amplifier positive terminal (constant input impedance).
	4	RIP2INPPGA	1	Connect RIP pin to right channel input PGA amplifier positive terminal. 0 = RIP not connected to input PGA 1 = right channel input PGA amplifier positive terminal connected to RIP (constant input impedance)
	5	RIN2INPPGA	1	Connect RIN pin to right channel input PGA negative terminal. 0 = RIN not connected to input PGA 1 = RIN connected to right channel input PGA amplifier negative terminal.
	6	R2_2INPPGA	0	Connect R2 pin to right channel input PGA positive terminal. 0 = R2 not connected to input PGA 1 = R2 connected to input PGA amplifier positive terminal (constant input impedance).

Table 6 Input PGA Control

INPUT PGA VOLUME CONTROLS

The input microphone PGAs have a gain range from -12dB to +35.25dB in 0.75dB steps. The gain from the LIN/RIN input to the PGA output and from the L2/R2 amplifier to the PGA output are always common and controlled by the register bits INPPGAVOLL/R[5:0]. These register bits also affect the LIP pin when LIP2INPPGA=1, the L2 pin when L2_2INPPGA=1, the RIP pin when RIP2INPPGA=1 and the R2 pin when R2_2INPPGA=1.

When the Automatic Level Control (ALC) is enabled the input PGA gains are controlled automatically

and the INPPGAVOLL/R bits should not be used.

REGISTER ADDRESS	BIT	LABEL	DEFAULT	DESCRIPTION
R45 Left channel input PGA volume control	5:0	INPPGAVOLL	010000	Left channel input PGA volume 000000 = -12dB 000001 = -11.25dB . 010000 = 0dB . 111111 = +35.25dB
	6	INPPGAMUTEL	0	Mute control for left channel input PGA: 0 = Input PGA not muted, normal operation 1 = Input PGA muted (and disconnected from the following input BOOST stage).
	7	INPPGAZCL	0	Left channel input PGA zero cross enable: 0 = Update gain when gain register changes 1 = Update gain on 1 st zero cross after gain register write.
	8	INPPGAVU	Not latched	INPPGA left and INPPGA right volume do not update until a 1 is written to INPPGAVU (in reg 45 or 46) (See "Volume Updates" below)
R46 Right channel input PGA volume control	5:0	INPPGAVOLR	010000	Right channel input PGA volume 000000 = -12dB 000001 = -11.25db . 010000 = 0dB . 111111 = +35.25dB
	6	INPPGAMUTER	0	Mute control for right channel input PGA: 0 = Input PGA not muted, normal operation 1 = Input PGA muted (and disconnected from the following input BOOST stage).
	7	INPPGAZCR	0	Right channel input PGA zero cross enable: 0 = Update gain when gain register changes 1 = Update gain on 1 st zero cross after gain register write.
	8	INPPGAVU	Not latched	INPPGA left and INPPGA right volume do not update until a 1 is written to INPPGAVU (in reg 45 or 46) (See "Volume Updates" below)
R32 ALC control 1	8:7	ALCSEL	00	ALC function select: 00 = ALC disabled 01 = Right channel ALC enabled 10 = Left channel ALC enabled 11 = Both channels ALC enabled

Table 7 Input PGA Volume Control

VOLUME UPDATES

Volume settings will not be applied to the PGAs until a '1' is written to one of the INPPGAVU bits. This is to allow left and right channels to be updated at the same time, as shown in Figure 16.

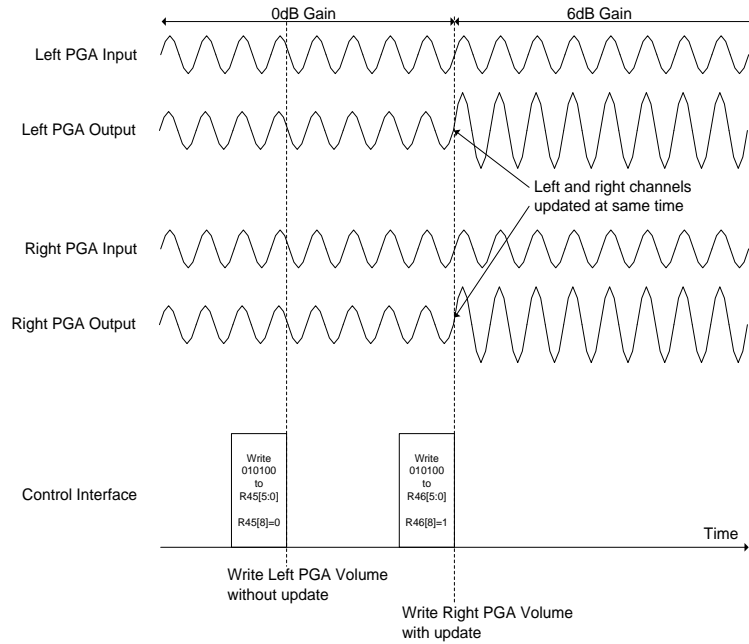

Figure 16 Simultaneous Left and Right Volume Updates

If the volume is adjusted while the signal is a non-zero value, an audible click can occur as shown in Figure 17.

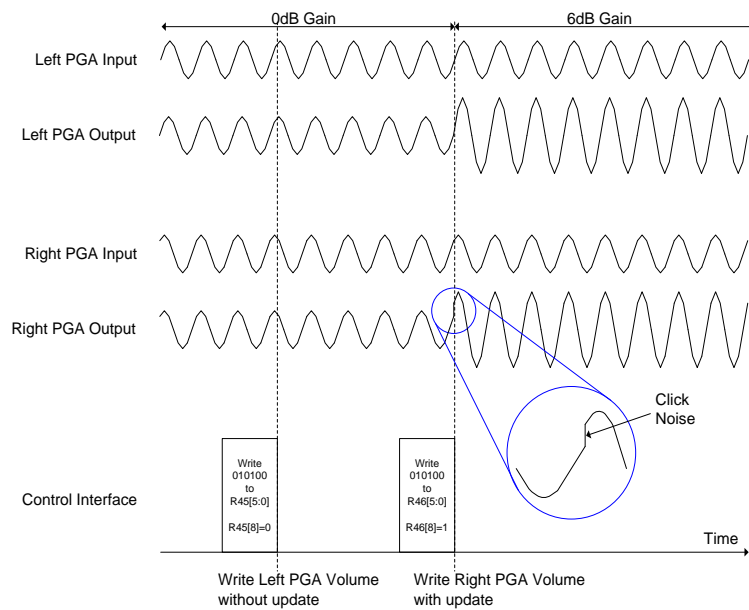

Figure 17 Click Noise during Volume Update

In order to prevent this click noise, a zero cross function is provided. When enabled, this will cause the PGA volume to update only when a zero crossing occurs, minimising click noise as shown in Figure 18.

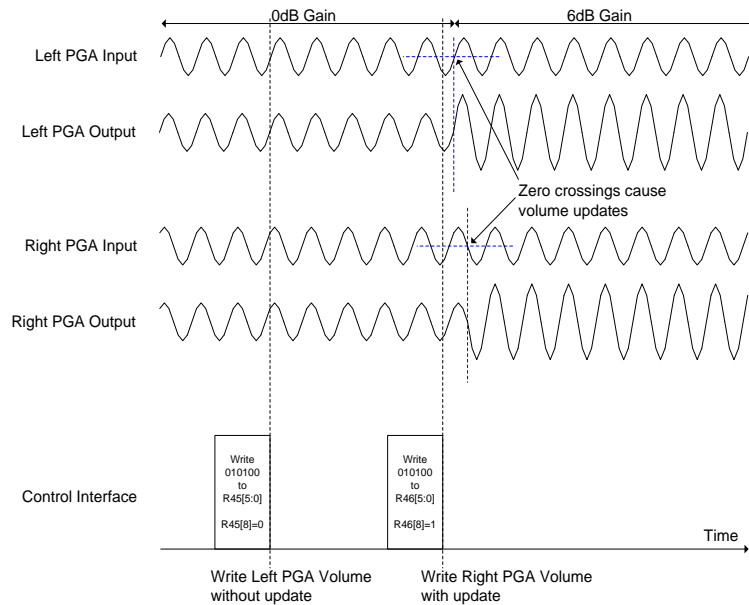

Figure 18 Volume Update Using Zero Cross Detection

If there is a long period where no zero-crossing occurs, a timeout circuit in the WM8983 will automatically update the volume. The volume updates will occur between one and two timeout periods, depending on when the INPPGAVU bit is set as shown in Figure 19.

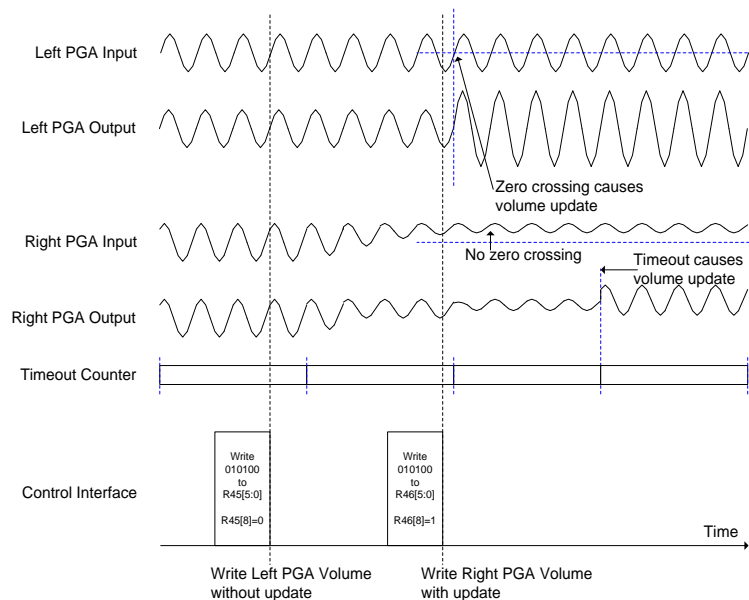

Figure 19 Volume Update after Timeout

AUXILIARY INPUTS

There are two auxiliary inputs, AUXL and AUXR which can be used for a variety of purposes such as stereo line inputs or as a 'beep' input signal to be mixed with the outputs.

As signal inputs, AUXL/R inputs can be used as a line input to the input BOOST stage which has adjustable gain of -12dB to +6dB in 3dB steps, with an additional "off" state (i.e. not connected to ADC input). See the INPUT BOOST section for further details.

The AUXL/R inputs can also be mixed into the output channel mixers, with a gain of -15dB to +6dB plus off.

INPUT BOOST

Each of the stereo input PGA stages is followed by an input BOOST circuit. The input BOOST circuit has 4 selectable inputs: the input microphone PGA output, the AUX amplifier output and the L2/R2 and AUXL/AUXR input pins (L2/R2 can be used as a line input, bypassing the input PGA). These four inputs can be mixed together and have individual gain boost/adjust as shown in Figure 20.

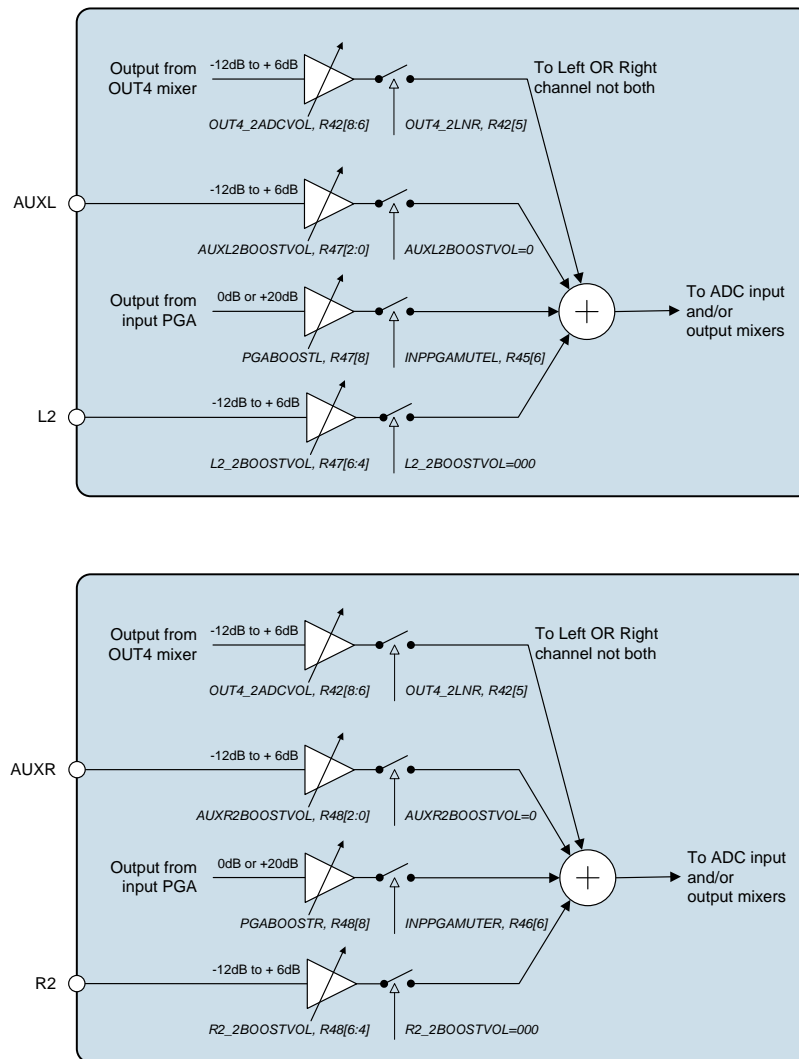

Figure 20 Input Boost Stage

The input PGA paths can have a +20dB boost (PGABOOSTL/R=1) , a 0dB pass through (PGABOOSTL/R=0) or be completely isolated from the input boost circuit (INPPGAMUTEL/R=1).

REGISTER ADDRESS	BIT	LABEL	DEFAULT	DESCRIPTION
R47 Left Input BOOST control	8	PGABOOSTL	1	Boost enable for left channel input PGA: 0 = PGA output has +0dB gain through input BOOST stage. 1 = PGA output has +20dB gain through input BOOST stage.
R48 Right Input BOOST control	8	PGABOOSTR	1	Boost enable for right channel input PGA: 0 = PGA output has +0dB gain through input BOOST stage. 1 = PGA output has +20dB gain through input BOOST stage.

Table 8 Input BOOST Stage Control

The Auxiliary amplifier path to the BOOST stages is controlled by the AUXL2BOOSTVOL[2:0] and AUXR2BOOSTVOL[2:0] register bits. When AUXL2BOOSTVOL/AUXR2BOOSTVOL=000, this path is completely disconnected from the BOOST stage. Settings 001 through to 111 control the gain in 3dB steps from -12dB to +6dB.

The L2/R2 path to the BOOST stage is controlled by the L2_2BOOSTVOL[2:0] and the R2_2BOOSTVOL[2:0] register bits. When L2_2BOOSTVOL/R2_2BOOSTVOL=000, the L2/R2 input pin is completely disconnected from the BOOST stage. Settings 001 through to 111 control the gain in 3dB steps from -12dB to +6dB.

The OUT4 mixer path to the BOOST stage is controlled by the OUT4_2ADCVOL[2:0] and OUT4_2LNR register bits. The OUT4 mixer signal can be routed to the Left Boost or the Right Boost stage, but not both at the same time. When OUT4_2ADCVOL=000, the OUT4 mixer path is completely disconnected from the BOOST stage.

REGISTER ADDRESS	BIT	LABEL	DEFAULT	DESCRIPTION
R42 OUT4 to ADC	8:6	OUT4_2ADCVOL	000	Controls the OUT4 to ADC input boost stage: 000 = Path disabled (disconnected) 001 = -12dB gain 010 = -9dB gain 011 = -6dB gain 100 = -3dB gain 101 = +0dB gain 110 = +3dB gain 111 = +6dB gain
	5	OUT4_2LNR	0	OUT4 to L or R ADC input 0 = Right ADC input 1 = Left ADC input

REGISTER ADDRESS	BIT	LABEL	DEFAULT	DESCRIPTION
R47 Left channel Input BOOST control	2:0	AUXL2BOOSTVOL	000	Controls the auxiliary amplifier to the left channel input boost stage: 000 = Path disabled (disconnected) 001 = -12dB gain 010 = -9dB gain 011 = -6dB gain 100 = -3dB gain 101 = +0dB gain 110 = +3dB gain 111 = +6dB gain
	6:4	L2_2BOOSTVOL	000	Controls the L2 pin to the left channel input boost stage: 000 = Path disabled (disconnected) 001 = -12dB gain 010 = -9dB gain 011 = -6dB gain 100 = -3dB gain 101 = +0dB gain 110 = +3dB gain 111 = +6dB gain
R48 Right channel Input BOOST control	2:0	AUXR2BOOSTVOL	000	Controls the auxiliary amplifier to the right channel input boost stage: 000 = Path disabled (disconnected) 001 = -12dB gain 010 = -9dB gain 011 = -6dB gain 100 = -3dB gain 101 = +0dB gain 110 = +3dB gain 111 = +6dB gain
	6:4	R2_2BOOSTVOL	000	Controls the R2 pin to the right channel input boost stage: 000 = Path disabled (disconnected) 001 = -12dB 010 = -9dB gain 011 = -6dB gain 100 = -3dB gain 101 = +0dB gain 110 = +3dB gain 111 = +6dB gain

Table 9 Input BOOST Stage Control

The BOOST stage is enabled under control of the BOOSTEN register bit.

REGISTER ADDRESS	BIT	LABEL	DEFAULT	DESCRIPTION
R2 Power management 2	4	BOOSTENL	0	Left channel Input BOOST enable 0 = Boost stage OFF 1 = Boost stage ON
	5	BOOSTENR	0	Right channel Input BOOST enable 0 = Boost stage OFF 1 = Boost stage ON

Table 10 Input BOOST Enable Control

MICROPHONE BIASING CIRCUIT

The MICBIAS output provides a low noise reference voltage suitable for biasing electret type microphones and the associated external resistor biasing network. Refer to the Applications Information section for recommended external components. The MICBIAS voltage can be altered via the MBVSEL register bit. When MBVSEL=0, MICBIAS=0.9*AVDD1 and when MBVSEL=1, MICBIAS=0.65*AVDD1. The output can be enabled or disabled using the MICBEN control bit.

REGISTER ADDRESS	BIT	LABEL	DEFAULT	DESCRIPTION
R1 Power management 1	4	MICBEN	0	Microphone Bias Enable 0 = OFF (high impedance output) 1 = ON

Table 11 Microphone Bias Enable Control

REGISTER ADDRESS	BIT	LABEL	DEFAULT	DESCRIPTION
R44 Input control	8	MBVSEL	0	Microphone Bias Voltage Control 0 = 0.9 * AVDD1 1 = 0.65 * AVDD1

Table 12 Microphone Bias Voltage Control

The internal MICBIAS circuitry is shown in Figure 21. Note that the maximum source current capability for MICBIAS is 3mA. The external biasing resistors therefore must be large enough to limit the MICBIAS current to 3mA.

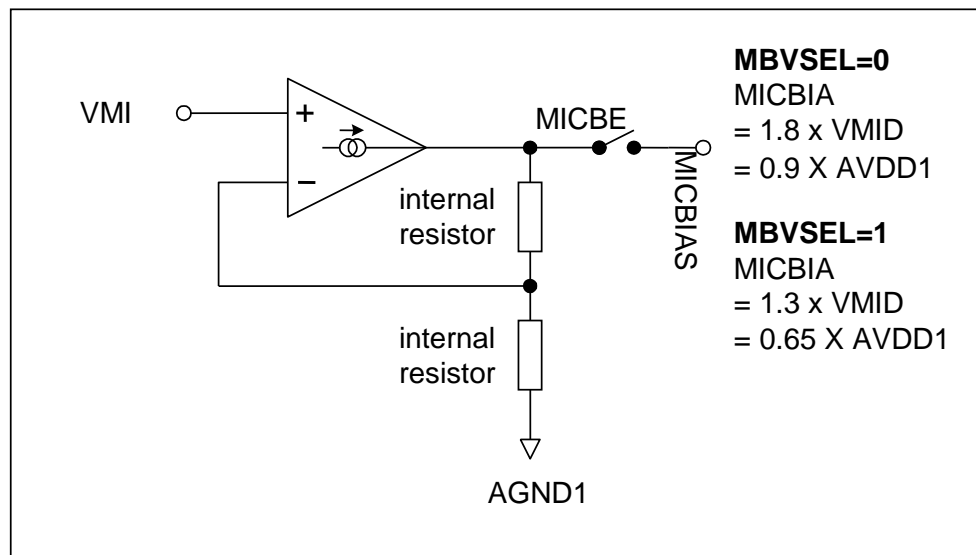

Figure 21 Microphone Bias Schematic

ANALOGUE TO DIGITAL CONVERTER (ADC)

The WM8983 uses stereo multi-bit, oversampled sigma-delta ADCs. The use of multi-bit feedback and high oversampling rates reduces the effects of jitter and high frequency noise. The ADC Full Scale input level is proportional to AVDD1. With a 3.3V supply voltage, the full scale level is $1.0V_{rms}$. Any voltage greater than full scale may overload the ADC and cause distortion.

ADC DIGITAL FILTERS

The ADC filters perform true 24 bit signal processing to convert the raw multi-bit oversampled data from the ADC to the correct sampling frequency to be output on the digital audio interface. The digital filter path for each ADC channel is illustrated in Figure 22.

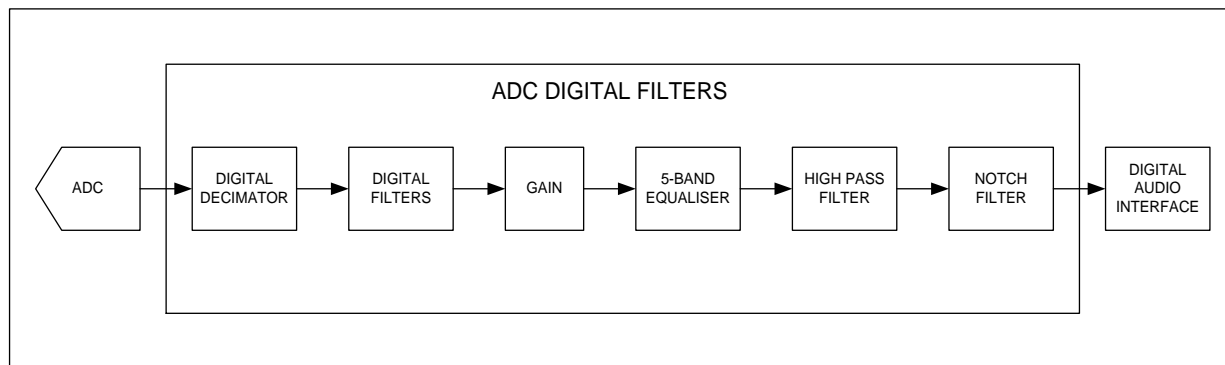

Figure 22 ADC Digital Filter Path

The ADCs are enabled by the ADCENL/R register bit.

REGISTER ADDRESS	BIT	LABEL	DEFAULT	DESCRIPTION
R2 Power management 2	0	ADCENL	0	Enable ADC left channel: 0 = ADC disabled 1 = ADC enabled
	1	ADCENR	0	Enable ADC right channel: 0 = ADC disabled 1 = ADC enabled

Table 13 ADC Enable Control

The polarity of the output signal can also be changed under software control using the ADCLPOL/ADCRPOL register bit. The oversampling rate of the ADC can be adjusted using the ADCOSR128 register bit. With ADCOSR128=0 the oversample rate is 64x which gives lowest power operation and when ADCOSR128=1 the oversample rate is 128x which gives best performance.

REGISTER ADDRESS	BIT	LABEL	DEFAULT	DESCRIPTION
R14 ADC Control	0	ADCLPOL	0	ADC left channel polarity adjust: 0 = normal 1 = inverted
	1	ADCRPOL	0	ADC right channel polarity adjust: 0 = normal 1 = inverted
	3	ADCOSR128	0	ADC oversample rate select: 0 = 64x (lowest power) 1 = 128x (best performance)

Table 14 ADC Control

SELECTABLE HIGH PASS FILTER

A selectable high pass filter is provided. To disable this filter, set HPFEN=0. The filter has two modes controlled by HPFAPP. In Audio Mode (HPFAPP=0), the filter is first order, with a cut-off frequency of 3.7Hz. In Application Mode (HPFAPP=1), the filter is second order, with a cut-off frequency selectable via the HPFCUT register. The cut-off frequencies when HPFAPP=1 are shown in Table 15.

REGISTER ADDRESS	BIT	LABEL	DEFAULT	DESCRIPTION
R14 ADC Control	8	HPFEN	1	High Pass Filter Enable 0 = disabled 1 = enabled
	7	HPFAPP	0	Select audio mode or application mode 0 = Audio mode (1 st order, fc = ~3.7Hz) 1 = Application mode (2 nd order, fc = HPFCUT)
	6:4	HPFCUT	000	Application mode cut-off frequency See Table 16 for details.

Table 15 ADC Enable Control

HPFCUT [2:0]	SR=101/100			SR=011/010			SR=001/000		
	fs (kHz)								
	8	11.025	12	16	22.05	24	32	44.1	48
000	82	113	122	82	113	122	82	113	122
001	102	141	153	102	141	153	102	141	153
010	131	180	156	131	180	156	131	180	196
011	163	225	245	163	225	245	163	225	245
100	204	281	306	204	281	306	204	281	306
101	261	360	392	261	360	392	261	360	392
110	327	450	490	327	450	490	327	450	490
111	408	563	612	408	563	612	408	563	612

Table 16 High Pass Filter Cut-off Frequencies (HPFAPP=1)

Note that the High Pass filter values (when HPFAPP=1) are calculated on the assumption that the SR register bits are set correctly for the actual sample rate as shown in Table 16. Sampling rate (SR) is selected using register bits R7[3:1].

PROGRAMMABLE IIR NOTCH FILTER

A programmable notch filter is provided. This filter has a variable centre frequency and bandwidth, programmable via two coefficients, a_0 and a_1 . a_0 and a_1 are represented by the register bits NFA0[13:0] and NFA1[13:0]. Because these coefficient values require four register writes to setup there is an NFU (Notch Filter Update) flag which should be set only when all four registers are setup.

REGISTER ADDRESS	BIT	LABEL	DEFAULT	DESCRIPTION
R27 Notch Filter 1	6:0	NFA0[13:7]	0	Notch Filter a_0 coefficient, bits [13:7]
	7	NFEN	0	Notch filter enable: 0 = Disabled 1 = Enabled
	8	NFU	0	Notch filter update. The notch filter values used internally only update when one of the NFU bits is set high.
R28 Notch Filter 2	6:0	NFA0[6:0]	0	Notch Filter a_0 coefficient, bits [6:0]
	8	NFU	0	Notch filter update. The notch filter values used internally only update when one of the NFU bits is set high.
R29 Notch Filter 3	6:0	NFA1[13:7]	0	Notch Filter a_1 coefficient, bits [13:7]
	8	NFU	0	Notch filter update. The notch filter values used internally only update when one of the NFU bits is set high.
R30 Notch Filter 4	0-6	NFA1[6:0]	0	Notch Filter a_1 coefficient, bits [6:0]
	8	NFU	0	Notch filter update. The notch filter values used internally only update when one of the NFU bits is set high.

Table 17 Notch Filter Function

The coefficients are calculated as follows:

$$a_0 = \frac{1 - \tan(w_b/2)}{1 + \tan(w_b/2)}$$

$$a_1 = -(1 + a_0)\cos(w_0)$$

Where:

$$w_0 = 2\pi f_c / f_s$$

$$w_b = 2\pi f_b / f_s$$

f_c = centre frequency in Hz, f_b = -3dB bandwidth in Hz, f_s = sample frequency in Hz

The actual register values can be determined from the coefficients as follows:

$$\text{NFA0} = -a_0 \times 2^{13}$$

$$\text{NFA1} = -a_1 \times 2^{12}$$

NOTCH FILTER WORKED EXAMPLE

The following example illustrates how to calculate the a_0 and a_1 coefficients for a desired centre frequency and -3dB bandwidth.

$$F_c = 1000 \text{ Hz}$$

$$f_b = 100 \text{ Hz}$$

$$f_s = 48000 \text{ Hz}$$

$$w_0 = \frac{2\pi f_c}{f_s} = 2\pi \left(\frac{1000}{48000} \right) = 0.1308996939 \text{ rads}$$

$$w_b = \frac{2\pi f_b}{f_s} = 2\pi \left(\frac{100}{48000} \right) = 0.01308996939 \text{ rads}$$

$$a_0 = \frac{1 - \tan(w_b/2)}{1 + \tan(w_b/2)} = \frac{1 - \tan(0.01308996939/2)}{1 + \tan(0.01308996939/2)} = 0.9869949627$$

$$a_1 = -(1 + a_0) \cos(w_0) = -(1 + 0.9869949627) \cos(0.1308996939) = -1.969995945$$

$$\text{NFA0} = -a_0 \times 2^{13} = -8085 \text{ (rounded to nearest whole number)}$$

$$\text{NFA1} = -a_1 \times 2^{12} = 8069 \text{ (rounded to nearest whole number)}$$

These values are then converted to a 2's complement notation:

$$\text{NFA0}[13:0] = 14'h1F95; \text{ Converting to 2's complement NFA0} = 14'h4000 - 14'h1F95 = 14'h206B$$

$$\text{NFA1}[13:0] = 14'h1F85; \text{ Converting to 2's complement NFA1} = 14'h1F85$$

DIGITAL ADC VOLUME CONTROL

The output of the ADCs can be digitally attenuated over a range from -127dB to 0dB in 0.5dB steps. The gain for a given eight-bit code X is given by:

$$0.5 \times (G-255) \text{ dB for } 1 \leq G \leq 255; \quad \text{MUTE for } G = 0$$

REGISTER ADDRESS	BIT	LABEL	DEFAULT	DESCRIPTION
R15 Left channel ADC Digital Volume	7:0	ADCLVOL [7:0]	11111111 (0dB)	Left ADC Digital Volume Control 0000 0000 = Digital Mute 0000 0001 = -127dB 0000 0010 = -126.5dB ... 0.5dB steps up to 1111 1111 = 0dB
	8	ADCVU	Not latched	ADC left and ADC right volume do not update until a 1 is written to ADCVU (in reg 15 or 16)
R16 Right channel ADC Digital Volume	7:0	ADCRVOL [7:0]	11111111 (0dB)	Right ADC Digital Volume Control 0000 0000 = Digital Mute 0000 0001 = -127dB 0000 0010 = -126.5dB ... 0.5dB steps up to 1111 1111 = 0dB
	8	ADCVU	Not latched	ADC left and ADC right volume do not update until a 1 is written to ADCVU (in reg 15 or 16)

Table 18 ADC Digital Volume Control

INPUT LIMITER / AUTOMATIC LEVEL CONTROL (ALC)

The WM8983 has an automatic PGA gain control circuit, which can function as an input peak limiter or as an automatic level control (ALC).

The Automatic Level Control (ALC) provides continuous adjustment of the input PGA in response to the amplitude of the input signal. A digital peak detector monitors the input signal amplitude and compares it to a register defined threshold level (ALCLVL).

If the signal is below the threshold, the ALC will increase the gain of the PGA at a rate set by ALCDCY. If the signal is above the threshold, the ALC will reduce the gain of the PGA at a rate set by ALCATK.

The ALC has two modes selected by the ALCMODE register: normal mode and peak limiter mode. The ALC/limiter function is enabled by settings the register bits R32[8:7] ALCSEL.

REGISTER ADDRESS	BIT	LABEL	DEFAULT	DESCRIPTION
R32 (20h) ALC Control 1	2:0	ALCMIN [2:0]	000 (-12dB)	Set minimum gain of PGA 000 = -12dB 001 = -6dB 010 = 0dB 011 = +6dB 100 = +12dB 101 = +18dB 110 = +24dB 111 = +30dB

REGISTER ADDRESS	BIT	LABEL	DEFAULT	DESCRIPTION
	5:3	ALCMAX [2:0]	111 (+35.25dB)	Set Maximum Gain of PGA 111 = +35.25dB 110 = +29.25dB 101 = +23.25dB 100 = +17.25dB 011 = +11.25dB 010 = +5.25dB 001 = -0.75dB 000 = -6.75dB
	8:7	ALCSEL	00	ALC function select 00 = ALC disabled 01 = Right channel ALC enabled 10 = Left channel ALC enabled 11 = Both channels ALC enabled
R33 (21h) ALC Control 2	3:0	ALCLVL [3:0]	1011 (-6dB)	ALC target – sets signal level at ADC input 1111 = -1.5dBFS 1110 = -1.5dBFS 1101 = -3dBFS 1100 = -4.5dBFS 1011 = -6dBFS 1010 = -7.5dBFS 1001 = -9dBFS 1000 = -10.5dBFS 0111 = -12dBFS 0110 = -13.5dBFS 0101 = -15dBFS 0100 = -16.5dBFS 0011 = -18dBFS 0010 = -19.5dBFS 0001 = -21dBFS 0000 = -22.5dBFS
	7:4	ALCHLD [3:0]	0000 (0ms)	ALC hold time before gain is increased. 0000 = 0ms 0001 = 2.67ms 0010 = 5.33ms 0011 = 10.66ms 0100 = 21.32ms 0101 = 42.64ms 0110 = 85.28ms 0111 = 0.17s 1000 = 0.34s 1001 = 0.68s 1010 = 1.36s 1011 = 2.7s 1100 = 5.4s 1101 = 10.9s 1110 = 21.8 s 1111 = 43.7s
R34 (22h) ALC Control 3	8	ALCMODE	0	Determines the ALC mode of operation: 0 = ALC mode (Normal Operation) 1 = Limiter mode.

REGISTER ADDRESS	BIT	LABEL	DEFAULT	DESCRIPTION			
	7:4	ALCDCY [3:0]	0011 (13ms/6dB)	Decay (gain ramp-up) time (ALCMODE ==0)			
					Per step	Per 6dB	90% of range
				0000	410us	3.3ms	24ms
				0001	820us	6.6ms	48ms
				0010	1.64ms	13.1ms	192ms
				... (time doubles with every step)			
				1010 or higher	420ms	3.36s	24.576s
	0011 (2.9ms/6dB)	Decay (gain ramp-up) time (ALCMODE ==1)					
			Per step	Per 6dB	90% of range		
		0000	90.8us	726.4us	5.26ms		
		0001	181.6us	1.453ms	10.53ms		
		0010	363.2us	2.905ms	21.06ms		
		... (time doubles with every step)					
		1010	93ms	744ms	5.39s		
	3:0	ALCATK [3:0]	0010 (832us/6dB)	ALC attack (gain ramp-down) time (ALCMODE == 0)			
					Per step	Per 6dB	90% of range
				0000	104us	832us	6ms
				0001	208us	1.66ms	12ms
				0010	416us	3.32ms	24.1ms
				... (time doubles with every step)			
				1010 or higher	106ms	852ms	6.18s
	0010 (182us/6dB)	ALC attack (gain ramp-down) time (ALCMODE == 1)					
			Per step	Per 6dB	90% of range		
		0000	22.7us	182.4us	1.31ms		
		0001	45.4us	363.2us	2.62ms		
		0010	90.8us	726.4us	5.26ms		
		... (time doubles with every step)					
		1010	23.2ms	186ms	1.348s		

Table 19 ALC Control Registers

When the ALC is disabled, the input PGA remains at the last controlled value of the ALC. An input gain update must be made by writing to the INPPGAVOLL/R register bits.

NORMAL MODE

In normal mode, the ALC will attempt to maintain a constant signal level by increasing or decreasing the gain of the PGA. The following diagram shows an example of this.

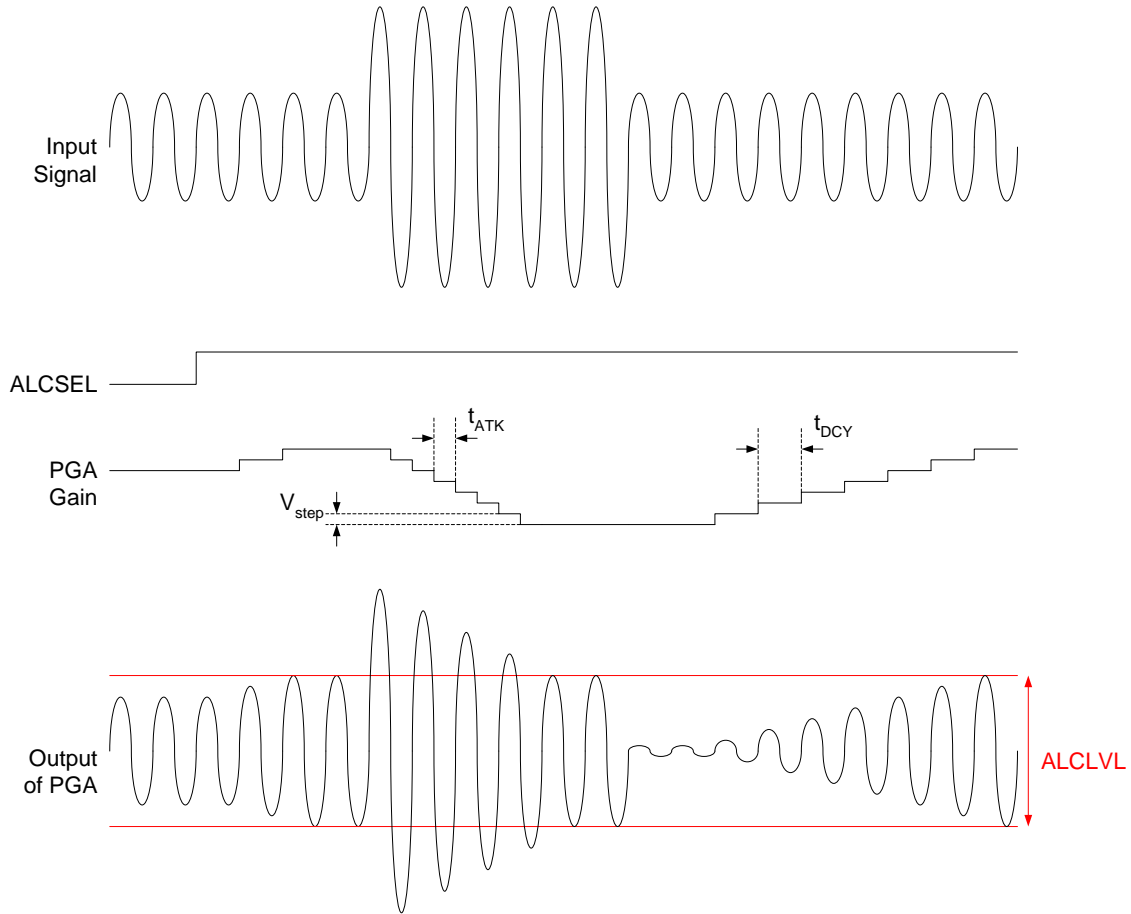

Figure 23 ALC Normal Mode Operation

LIMITER MODE

In limiter mode, the ALC will reduce peaks that go above the threshold level, but will not increase the PGA gain beyond the starting level. The starting level is the PGA gain setting when the ALC is enabled in limiter mode. If the ALC is started in limiter mode, this is the gain setting of the PGA at startup. If the ALC is switched into limiter mode after running in ALC mode, the starting gain will be the gain at switchover. The diagram below shows an example of limiter mode.

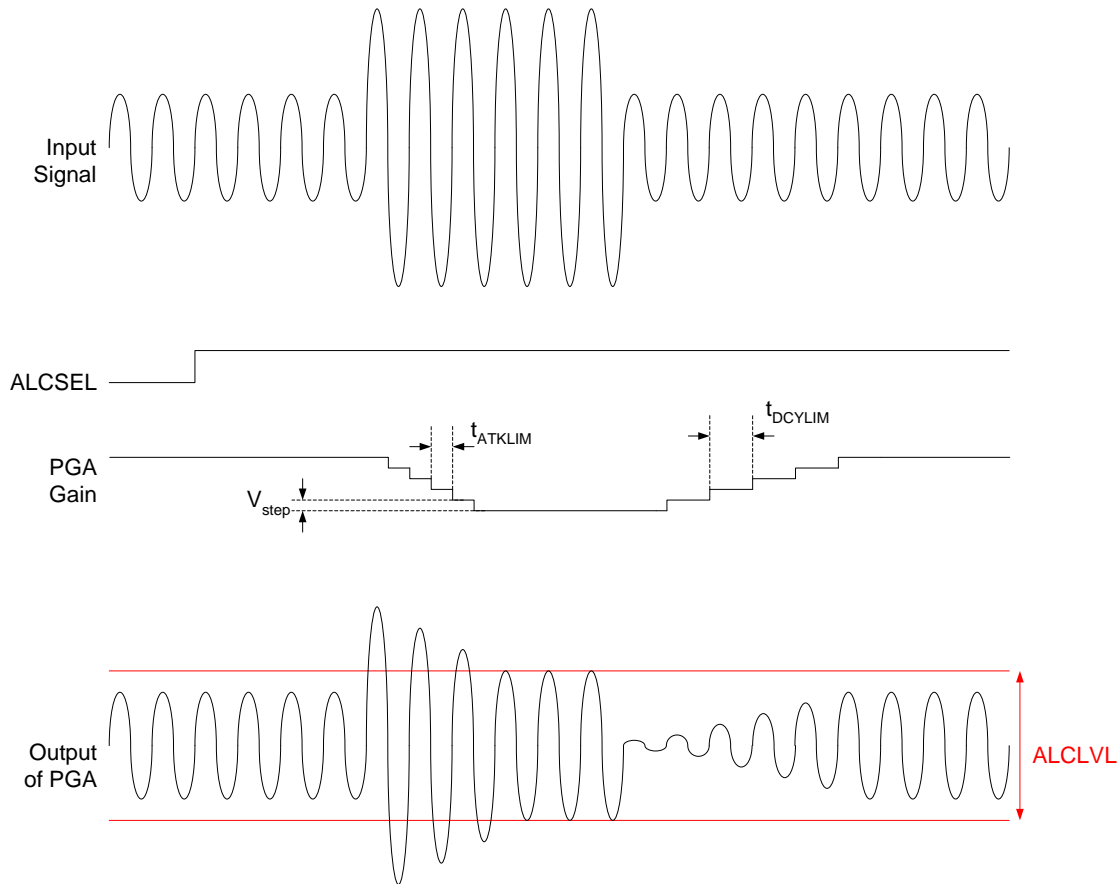

Figure 24 ALC Limiter Mode Operation

ALC LIMITER MODE INITIALISATION SEQUENCE

In order to correctly initialise the ALC in limiter mode, the following sequence of register writes is required. MCLK must be applied during the initialisation sequence

1. R45 - Set left input PGA gain (INPPGAVOLL) to level required for operation.
2. R46 - Set right input PGA gain (INPPGAVOLR) to level required for operation.
3. R44 - Enable analogue inputs as required.
4. R2 - Disable input PGA (INPPGAENL=0, INPPGAENR=0).
5. R59 = 0x0003 - Enable ALC test mode.
6. R32 - Set ALCMAX and ALCMIN to the level required for operation.
7. R33 - Set limiter level (ALCLVL) to the level required for operation.
8. R34 = 0x0000 - Enable ALC mode (ALCMODE = 0).
9. Insert 1ms delay to allow input PGA gain update by the limiter circuit.
10. R34 = 0x0100 - Enable Limiter mode (ALCMODE = 1).
11. Insert 1ms delay to allow input PGA gain update by the limiter circuit.
12. R59 = 0x0000 - Turn off ALC test mode.
13. R2 - Enable input PGA (INPPGAENL=1, INPPGAENR=1).

Note: R32, R33, R45 and R46 register settings above need to be changed to reflect settings required in the target application.

ATTACK AND DECAY TIMES

The attack and decay times set the update times for the PGA gain. The attack time is the time constant used when the gain is reducing. The decay time is the time constant used when the gain is increasing. In limiter mode, the time constants are faster than in ALC mode. The time constants are shown below in terms of a single gain step, a change of 6dB and a change of 90% of the PGAs gain range.

Note that, these times will vary slightly depending on the sample rate used (specified by the SR register).

NORMAL MODE

ALCMODE = 0 (Normal Mode)			
Attack Time (s)			
ALCATK	t _{ATK}	t _{ATK6dB}	t _{ATK90%}
0000	104µs	832µs	6ms
0001	208µs	1.66ms	12ms
0010	416µs	3.33ms	24ms
0011	832µs	6.66ms	48ms
0100	1.66ms	13.32ms	96ms
0101	3.33ms	26.64ms	192ms
0110	6.66ms	53.28ms	384ms
0111	13.32ms	106.6ms	768ms
1000	26.64ms	213.2ms	1.53s
1001	53.28ms	426.4ms	3.07s
1010	106.6ms	852.8ms	6.14s

ALCMODE = 0 (Normal Mode)			
Decay Time (s)			
ALCDCY	t _{DCY}	t _{DCY6dB}	t _{DCY90%}
0000	410µs	3.3ms	24ms
0001	820µs	6.6ms	48ms
0010	1.64ms	13.1ms	96ms
0011	3.28ms	26.2ms	192ms
0100	6.56ms	52.5ms	384ms
0101	13.12ms	105ms	768ms
0110	26.24ms	210ms	1.53s
0111	52.5ms	420ms	3.07s
1000	105ms	840ms	6.14s
1001	210ms	1.68s	12.28s
1010	420ms	3.36s	24.57s

Table 20 ALC Normal Mode (Attack and Decay times)
LIMITER MODE

ALCMODE = 1 (Limiter Mode)			
Attack Time (s)			
ALCATK	t _{ATKLIM}	t _{ATKLIM6dB}	t _{ATKLIM90%}
0000	22.7µs	182.4µs	1.31ms
0001	45.4µs	363.2µs	2.62ms
0010	90.8µs	726.4µs	5.24ms
0011	182µs	1.45ms	10.48ms
0100	363µs	2.9ms	20.9ms
0101	726µs	5.81ms	41.9ms
0110	1.45ms	11.62ms	83.8ms
0111	2.9ms	23.2ms	167.7ms
1000	5.81ms	46.5ms	335.4ms
1001	11.62ms	93ms	670.8ms
1010	23.2ms	186ms	1.34s

ALCMODE = 1 (Limiter Mode)			
Attack Time (s)			
ALCDCY	t _{DCYLIM}	t _{DCYLIM6dB}	t _{DCYLIM90%}
0000	90.8µs	726.4µs	5.24ms
0001	182µs	1.45ms	10.48ms
0010	363µs	2.9ms	20.9ms
0011	726µs	5.81ms	41.9ms
0100	1.45ms	11.62ms	83.8ms
0101	2.9ms	23.2ms	167.7ms
0110	5.81ms	46.5ms	335.4ms
0111	11.62ms	93ms	670.8ms
1000	23.2ms	186ms	1.34s
1001	46.4ms	372ms	2.68s
1010	92.8ms	744ms	5.36s

Table 21 ALC Limiter Mode (Attack and Decay times)

MINIMUM AND MAXIMUM GAIN

The ALCMIN and ALCMAX register bits set the minimum/maximum gain value that the PGA can be set to whilst under the control of the ALC. This has no effect on the PGA when ALC is not enabled.

REGISTER ADDRESS	BIT	LABEL	DEFAULT	DESCRIPTION
R32 ALC Control 1	5:3	ALCMAX	111	Set Maximum Gain of PGA (see Table 19 for definition)
	2:0	ALCMIN	000	Set minimum gain of PGA (see Table 19 for definition)

Table 22 ALC Max/Min Gain

In normal mode, ALCMAX sets the maximum boost which can be applied to the signal. In limiter mode, ALCMAX will normally have no effect (assuming the starting gain value is less than the maximum gain specified by ALCMAX) because the maximum gain is set at the starting gain level.

ALCMIN sets the minimum gain value which can be applied to the signal.

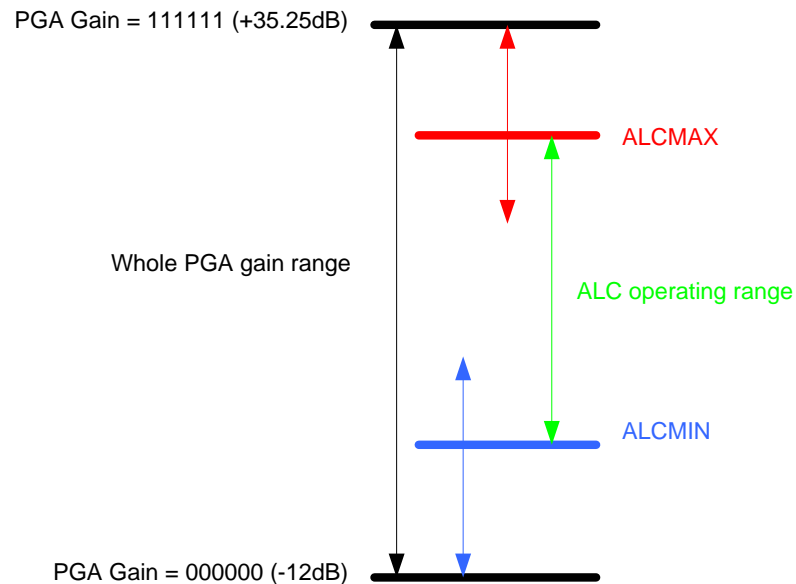
Figure 25 ALC Min/Max Gain

ALCMAX	Maximum Gain (dB)
111	35.25
110	29.25
101	23.25
100	17.25
011	11.25
010	5.25
001	-0.75
000	-6.75

Table 23 ALC Max Gain Values

ALCMIN	Minimum Gain (dB)
000	-12
001	-6
010	0
011	6
100	12
101	18
110	24
111	30

Table 24 ALC Min Gain Values

Note that if the ALC gain setting strays outside the ALC operating range, either by starting the ALC outside of the range or changing the ALCMAX or ALCMIN settings during operation, the ALC will immediately adjust the gain to return to the ALC operating range. It is recommended that the ALC starting gain is set between the ALCMAX and ALCMIN limits.

ALC HOLD TIME (NORMAL MODE ONLY)

In Normal mode, the ALC has an adjustable hold time which sets a time delay before the ALC begins its decay phase (gain increasing). The hold time is set by the ALCHLD register.

REGISTER ADDRESS	BIT	LABEL	DEFAULT	DESCRIPTION
R33 ALC Control 2	7:4	ALCHLD	0000	ALC hold time before gain is increased. (see Table 19 for definition)

Table 25 ALC Hold Time

If the hold time is exceeded, this indicates that the signal has reached a new average level and the ALC will increase the gain to adjust for that new average level. If the signal goes above the threshold during the hold period, the hold phase is abandoned and the ALC returns to normal operation.

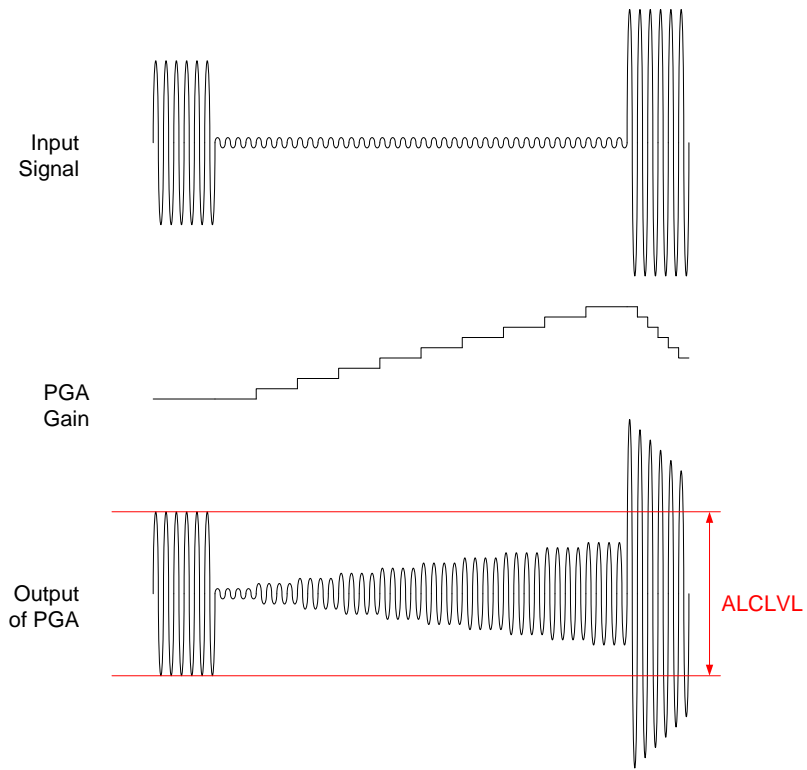

Figure 26 ALCLVL

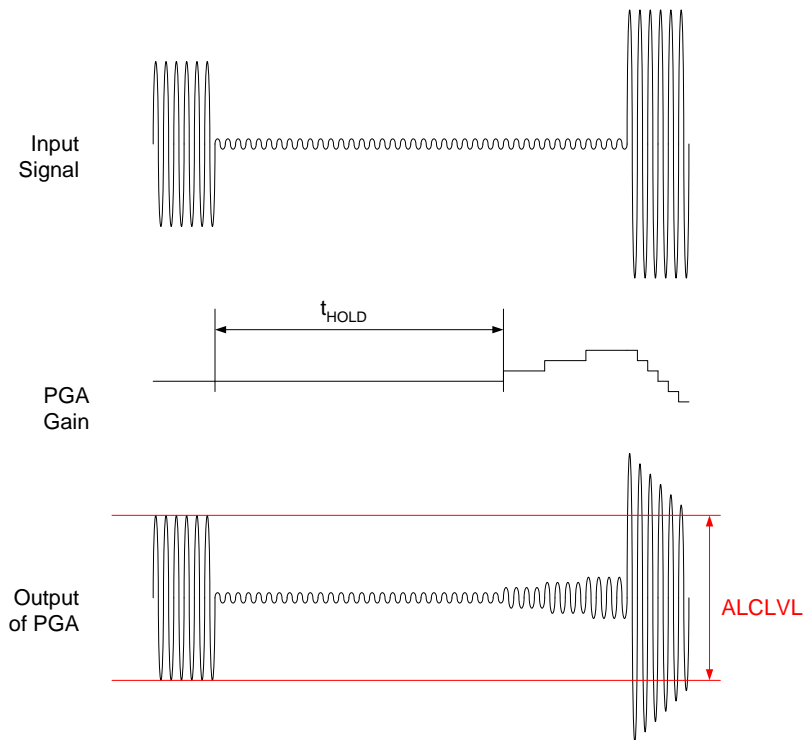

Figure 27 ALC Hold Time

ALCHLD	t _{HOLD} (s)
0000	0
0001	2.67ms
0010	5.34ms
0011	10.7ms
0100	21.4ms
0101	42.7ms
0110	85.4ms
0111	171ms
1000	342ms
1001	684ms
1010	1.37s

Table 26 ALC Hold Time Values

PEAK LIMITER

To prevent clipping when a large signal occurs just after a period of quiet, the ALC circuit includes a limiter function. If the ADC input signal exceeds 87.5% of full scale (−1.16dB), the PGA gain is ramped down at the maximum attack rate (as when ALCATK = 0000), until the signal level falls below 87.5% of full scale. This function is automatically enabled whenever the ALC is enabled.

Note: If ALCATK = 0000, then the limiter makes no difference to the operation of the ALC. It is designed to prevent clipping when long attack times are used.

NOISE GATE (NORMAL MODE ONLY)

When the signal is very quiet and consists mainly of noise, the ALC function may cause “noise pumping”, i.e. loud hissing noise during silence periods. The WM8985 has a noise gate function that prevents noise pumping by comparing the signal level at the input pins against a noise gate threshold, NGTH. The noise gate cuts in when:

$$\text{Signal level at ADC [dBFS]} < \text{NGTH [dBFS]} + \text{PGA gain [dB]} + \text{Mic Boost gain [dB]}$$

This is equivalent to:

$$\text{Signal level at input pin [dBFS]} < \text{NGTH [dBFS]}$$

The PGA gain is then held constant (preventing it from ramping up as it normally would when the signal is quiet).

The table below summarises the noise gate control register. The NGTH control bits set the noise gate threshold with respect to the ADC full-scale range. The threshold is adjusted in 6dB steps. Levels at the extremes of the range may cause inappropriate operation, so care should be taken with set-up of the function. The noise gate only operates in conjunction with the ALC and cannot be used in limiter mode.

REGISTER ADDRESS	BIT	LABEL	DEFAULT	DESCRIPTION
R35 (23h) ALC Noise Gate Control	2:0	NGTH	000	ALC Noise gate threshold: 000 = -39dB 001 = -45dB 010 = -51dB 011 = -57dB 100 = -63dB 101 = -70dB 110 = -76dB 111 = -81dB
	3	NGEN	0	ALC Noise gate function enable 1 = enable 0 = disable

Table 27 ALC Noise Gate Control

The diagrams below show the response of the system to the same signal with and without noise gate.

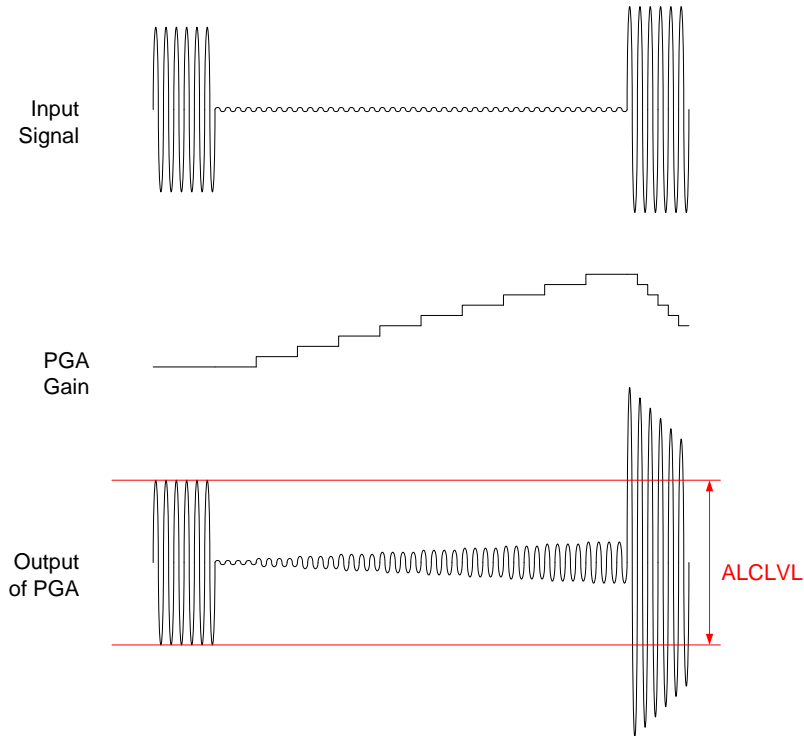
Figure 28 ALC Operation Above Noise Gate Threshold

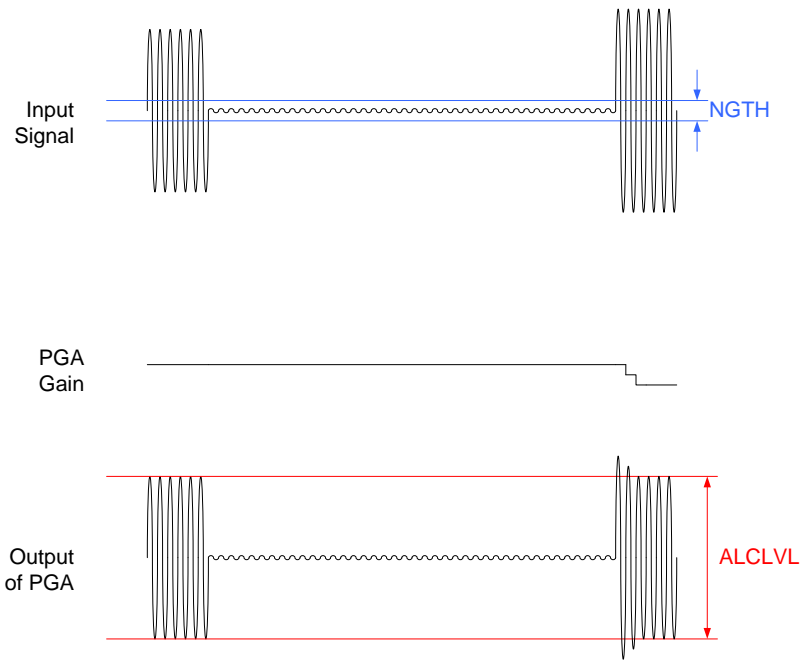

Figure 29 Noise Gate Operation

OUTPUT SIGNAL PATH

The WM8983 output signal paths consist of digital application filters, up-sampling filters, stereo Hi-Fi DACs, analogue mixers, stereo headphone and stereo line/mono/midrail output drivers. The digital filters and DAC are enabled by register bits DACENL And DACENR. The mixers and output drivers can be separately enabled by individual control bits (see Analogue Outputs). Thus it is possible to utilise the analogue mixing and amplification provided by the WM8983, irrespective of whether the DACs are running or not.

The WM8983 DACs receive digital input data on the DACDAT pin. The digital filter block processes the data to provide the following functions:

- Digital volume control
- Graphic equaliser
- A digital peak limiter.
- Sigma-Delta Modulation

High performance sigma-delta audio DAC converts the digital data into an analogue signal.

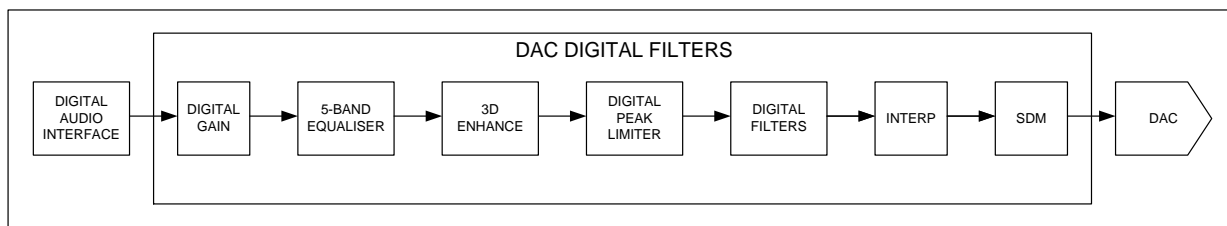

Figure 30 DAC Digital Filter Path

The analogue outputs from the DACs can then be mixed with the aux analogue inputs and the ADC analogue inputs. The mix is fed to the output drivers for headphone (LOUT1/ROUT1, LOUT2/ROUT2) or line (OUT3/OUT4). OUT3 and OUT4 have additional mixers which allow them to output different signals to the headphone and line outputs.

DIGITAL PLAYBACK (DAC) PATH

Digital data is passed to the WM8983 via the flexible audio interface and is then passed through a variety of advanced digital filters as shown in Figure 30 to the hi-fi DACs. The DACs are enabled by the DACENL/R register bits.

REGISTER ADDRESS	BIT	LABEL	DEFAULT	DESCRIPTION
R3 Power Management 3	0	DACENL	0	Left channel DAC enable 0 = DAC disabled 1 = DAC enabled
	1	DACENR	0	Right channel DAC enable 0 = DAC disabled 1 = DAC enabled

Table 28 DAC Enable Control

The WM8983 also has a Soft Mute function, which when enabled, gradually attenuates the volume of the digital signal to zero. When disabled, the gain will ramp back up to the digital gain setting. This function is enabled by default. To play back an audio signal, it must first be disabled by setting the SOFTMUTE bit to zero.

REGISTER ADDRESS	BIT	LABEL	DEFAULT	DESCRIPTION
R10 DAC Control	0	DACLPOL	0	Left DAC output polarity: 0 = non-inverted 1 = inverted (180 degrees phase shift)
	1	DACRPOL	0	Right DAC output polarity: 0 = non-inverted 1 = inverted (180 degrees phase shift)
	2	AMUTE	0	Automute enable 0 = Amute disabled 1 = Amute enabled
	3	DACOSR128	0	DAC oversampling rate: 0 = 64x (lowest power) 1 = 128x (best performance)
	6	SOFTMUTE	0	Softmute enable: 0 = Enabled 1 = Disabled

Table 29 DAC Control Register

The digital audio data is converted to oversampled bit streams in the on-chip, true 24-bit digital interpolation filters. The bitstream data enters the multi-bit, sigma-delta DACs, which convert it to a high quality analogue audio signal. The multi-bit DAC architecture reduces high frequency noise and sensitivity to clock jitter. It also uses a Dynamic Element Matching technique for high linearity and low distortion.

The DAC output phase defaults to non-inverted. Setting DACLPOL will invert the DAC output phase on the left channel and DACRPOL inverts the phase on the right channel.

AUTO-MUTE

The DAC has an auto-mute function which applies an analogue mute when 1024 consecutive zeros are detected. The mute is released as soon as a non-zero sample is detected. Auto-mute can be disabled using the AMUTE control bit.

DIGITAL HI-FI DAC VOLUME (GAIN) CONTROL

The signal volume from each Hi-Fi DAC can be controlled digitally. The gain range is -127dB to 0dB in 0.5dB steps. The level of attenuation for an eight-bit code X is given by:

$$0.5 \times (X-255) \text{ dB for } 1 \leq X \leq 255; \quad \text{MUTE for } X = 0$$

REGISTER ADDRESS	BIT	LABEL	DEFAULT	DESCRIPTION
R11 Left DAC Digital Volume	7:0	DACLVOL [7:0]	11111111 (0dB)	Left DAC Digital Volume Control 0000 0000 = Digital Mute 0000 0001 = -127dB 0000 0010 = -126.5dB ... 0.5dB steps up to 1111 1111 = 0dB
	8	DACVU	Not latched	DAC left and DAC right volume do not update until a 1 is written to DACVU (in reg 11 or 12)
R12 Right DAC Digital Volume	7:0	DACRVOL [7:0]	11111111 (0dB)	Right DAC Digital Volume Control 0000 0000 = Digital Mute 0000 0001 = -127dB 0000 0010 = -126.5dB ... 0.5dB steps up to 1111 1111 = 0dB
	8	DACVU	Not latched	DAC left and DAC right volume do not update until a 1 is written to DACVU (in reg 11 or 12)

Table 30 DAC Digital Volume Control

Note: An additional gain of up to 12dB can be added using the gain block embedded in the digital peak limiter circuit (see DAC DIGITAL OUTPUT LIMITER section).

5-BAND EQUALISER

A 5-band graphic equaliser function which can be used to change the output frequency levels to suit the environment. This can be applied to the ADC or DAC path and is described in the 5-BAND GRAPHIC EQUALISER section for further details on this feature.

3-D ENHANCEMENT

The WM8983 has an advanced digital 3-D enhancement feature which can be used to vary the perceived stereo separation of the left and right channels. Like the 5-band equaliser, this feature can be applied to either the ADC record path or the DAC playback path but not both simultaneously. Refer to the 3D STEREO ENHANCEMENT section for further details on this feature.

DAC DIGITAL OUTPUT LIMITER

The WM8983 has a digital output limiter function. The operation of this is shown in Figure 31. In this diagram, the upper graph shows the envelope of the input/output signals and the lower graph shows the gain characteristic.

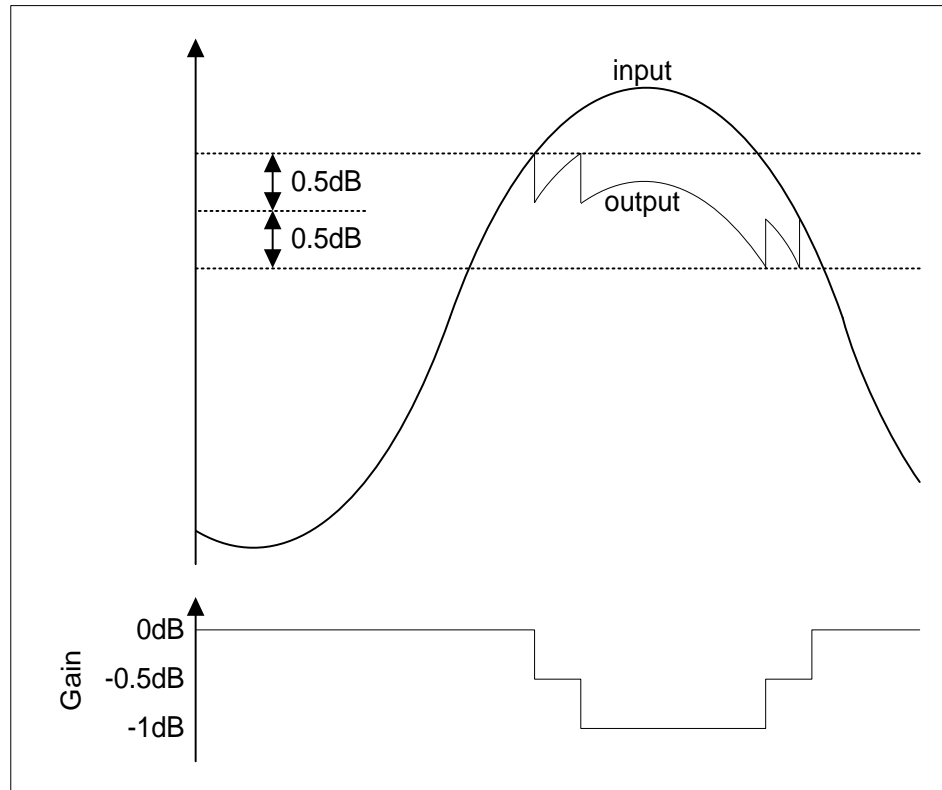

Figure 31 DAC Digital Limiter Operation

The limiter has a programmable upper threshold which is close to 0dB. Referring to Figure 31, in normal operation (LIMBOOST=000 => limit only), signals below this threshold are unaffected by the limiter. Signals above the upper threshold are attenuated at a specific attack rate (set by the LIMATK register bits) until the signal falls below the threshold. The limiter also has a lower threshold 1dB below the upper threshold. When the signal falls below the lower threshold, the signal is amplified at a specific decay rate (controlled by LIMDCY register bits) until a gain of 0dB is reached. Both threshold levels are controlled by the LIMLVL register bits. The upper threshold is 0.5dB above the value programmed by LIMLVL, and the lower threshold is 0.5dB below the LIMLVL value.

VOLUME BOOST

The limiter has programmable upper gain which boosts signals below the threshold to compress the dynamic range of the signal and increase its perceived loudness. This operates as an ALC function with limited boost capability. The volume boost is from 0dB to +12dB in 1dB steps, controlled by the LIMBOOST register bits.

The output limiter volume boost can also be used as a stand alone digital gain boost when the limiter is disabled.

REGISTER ADDRESS	BIT	LABEL	DEFAULT	DESCRIPTION
R24 DAC digital limiter control 1	3:0	LIMATK	0010	DAC Limiter Attack time (per 6dB gain change) for 44.1kHz sampling. Note that these are proportionally related to sample rate. 0000 = 94us 0001 = 188s 0010 = 375us 0011 = 750us 0100 = 1.5ms 0101 = 3ms 0110 = 6ms 0111 = 12ms 1000 = 24ms 1001 = 48ms 1010 = 96ms 1011 to 1111 = 192ms
	7:4	LIMDCY	0011	DAC Limiter Decay time (per 6dB gain change) for 44.1kHz sampling. Note that these are proportionally related to sample rate: 0000 = 750us 0001 = 1.5ms 0010 = 3ms 0011 = 6ms 0100 = 12ms 0101 = 24ms 0110 = 48ms 0111 = 96ms 1000 = 192ms 1001 = 384ms 1010 = 768ms 1011 to 1111 = 1.536s
	8	LIMEN	0	Enable the DAC digital limiter: 0 = disabled 1 = enabled
R25 DAC digital limiter control 2	3:0	LIMBOOST	0000	DAC Limiter volume boost (can be used as a stand alone volume boost when LIMEN=0): 0000 = 0dB 0001 = +1dB 0010 = +2dB 0011 = +3dB 0100 = +4dB 0101 = +5dB 0110 = +6dB 0111 = +7dB 1000 = +8dB 1001 = +9dB 1010 = +10dB 1011 = +11dB 1100 = +12dB 1101 to 1111 = reserved
	6:4	LIMLVL	000	Programmable signal threshold level (determines level at which the DAC limiter starts to operate) 000 = -1dB 001 = -2dB 010 = -3dB 011 = -4dB 100 = -5dB 101 to 111 = -6dB

Table 31 DAC Digital Limiter Control

5-BAND GRAPHIC EQUALISER

A 5-band graphic equaliser is provided, which can be applied to the ADC or DAC path, together with 3D enhancement, under control of the EQ3DMODE register bit.

REGISTER ADDRESS	BIT	LABEL	DEFAULT	DESCRIPTION
R18 EQ Control 1	8	EQ3DMODE	1	0 = Equaliser and 3D Enhancement applied to ADC path 1 = Equaliser and 3D Enhancement applied to DAC path

Table 32 EQ and 3D Enhancement DAC or ADC Path Select

Note: The ADCs and DACs must be disabled before changing the EQ3DMODE bit.

The equaliser consists of low and high frequency shelving filters (Band 1 and 5) and three peak filters for the centre bands. Each has adjustable cut-off or centre frequency, and selectable boost (+/- 12dB in 1dB steps). The peak filters have selectable bandwidth.

REGISTER ADDRESS	BIT	LABEL	DEFAULT	DESCRIPTION
R18 EQ Band 1 Control	4:0	EQ1G	01100 (0dB)	EQ Band 1 Gain Control. See Table 38 for details.
	6:5	EQ1C	01	EQ Band 1 Cut-off Frequency: 00 = 80Hz 01 = 105Hz 10 = 135Hz 11 = 175Hz

Table 33 EQ Band 1 Control

REGISTER ADDRESS	BIT	LABEL	DEFAULT	DESCRIPTION
R19 EQ Band 2 Control	4:0	EQ2G	01100 (0dB)	EQ Band 2 Gain Control. See Table 38 for details.
	6:5	EQ2C	01	EQ Band 2 Centre Frequency: 00 = 230Hz 01 = 300Hz 10 = 385Hz 11 = 500Hz
	8	EQ2BW	0	EQ Band 2 Bandwidth Control 0 = narrow bandwidth 1 = wide bandwidth

Table 34 EQ Band 2 Control

REGISTER ADDRESS	BIT	LABEL	DEFAULT	DESCRIPTION
R20 EQ Band 3 Control	4:0	EQ3G	01100 (0dB)	EQ Band 3 Gain Control. See Table 38 for details.
	6:5	EQ3C	01	EQ Band 3 Centre Frequency: 00 = 650Hz 01 = 850Hz 10 = 1.1kHz 11 = 1.4kHz
	8	EQ3BW	0	EQ Band 3 Bandwidth Control 0 = narrow bandwidth 1 = wide bandwidth

Table 35 EQ Band 3 Control

REGISTER ADDRESS	BIT	LABEL	DEFAULT	DESCRIPTION
R21 EQ Band 4 Control	4:0	EQ4G	01100 (0dB)	EQ Band 4 Gain Control. See Table 38 for details
	6:5	EQ4C	01	EQ Band 4 Centre Frequency: 00 = 1.8kHz 01 = 2.4kHz 10 = 3.2kHz 11 = 4.1kHz
	8	EQ4BW	0	EQ Band 4 Bandwidth Control 0 = narrow bandwidth 1 = wide bandwidth

Table 36 EQ Band 4 Control

REGISTER ADDRESS	BIT	LABEL	DEFAULT	DESCRIPTION
R22 EQ Band 5 Gain Control	4:0	EQ5G	01100 (0dB)	EQ Band 5 Gain Control. See Table 38 for details.
	6:5	EQ5C	01	EQ Band 5 Cut-off Frequency: 00 = 5.3kHz 01 = 6.9kHz 10 = 9kHz 11 = 11.7kHz

Table 37 EQ Band 5 Control

GAIN REGISTER	GAIN
00000	+12dB
00001	+11dB
00010	+10dB
00011	+9dB
00100	+8dB
00101	+7dB
00110	+6dB
00111	+5dB
01000	+4dB
01001	+3dB
01010	+2dB
01011	+1dB
01100	0dB
01101	-1dB
11000	-12dB
11001 to 11111	Reserved

Table 38 Gain Register Table

See also Figure 60 to Figure 77 for equaliser and high pass filter responses.

3D STEREO ENHANCEMENT

The WM8983 has a digital 3D enhancement option to increase the perceived separation between the left and right channels. Selection of 3D for record or playback is controlled by register bit EQ3DMODE. Switching this bit from record to playback or from playback to record may only be done when ADC and DAC are disabled. The WM8983 control interface will only allow EQ3DMODE to be changed when ADC and DAC are disabled (ie ADCENL = 0, ADCENR = 0, DACENL = 0 and DACENR = 0).

The DEPTH3D setting controls the degree of stereo expansion.

REGISTER ADDRESS	BIT	LABEL	DEFAULT	DESCRIPTION
R41 (29h) 3D Control	3:0	DEPTH3D[3:0]	0000	Stereo depth 0000 = Disabled 0001 = 6.67% 0010 = 13.3% 0011 = 20% 0100 = 26.7% 0101 = 33.3% 0110 = 40% 0111 = 46.6% 1000 = 53.3% 1001 = 60% 1010 = 66.7% 1011 = 73.3% 1100 = 80% 1101 = 86.7% 1110 = 93.3% 1111 = 100% (maximum 3D effect)

Table 39 3D Stereo Enhancement Function

Note: When 3D enhancement is used, it may be necessary to attenuate the signal by 6dB to avoid limiting.

ANALOGUE OUTPUTS

The WM8983 has three sets of stereo analogue outputs. These are:

- LOUT1 and ROUT1 which are normally used to drive a headphone load.
- LOUT2 and ROUT2 – which can be used as speaker, headphone or line drivers.
- OUT3 and OUT4 – can be configured as a stereo line out (OUT3 is left output and OUT4 is right output). OUT4 can also be used to provide a mono mix of left and right channels.

The outputs LOUT2, ROUT2, OUT3 and OUT4 are powered from AVDD2 and are capable of driving a 1V rms signal (AVDD1/3.3) in non-boost mode and AVDD1*1.5/3.3 in boost mode.

LOUT1 and ROUT1 are supplied from AVDD1 and can drive out a 1V rms signal (AVDD1/3.3).

LOUT1, ROUT1, LOUT2 and ROUT2 have individual analogue volume PGAs with -57dB to +6dB gain ranges.

There are four output mixers in the output signal path, the left and right channel mixers which control the signals to headphone (and optionally the line outputs) and also dedicated OUT3 and OUT4 mixers.

LEFT AND RIGHT OUTPUT CHANNEL MIXERS

The left and right output channel mixers are shown in Figure 32. These mixers allow the AUX inputs, the ADC bypass and the DAC left and right channels to be combined as desired. This allows a mono mix of the DAC channels to be performed as well as mixing in external line-in from the AUX or speech from the input bypass path.

The AUX and bypass inputs have individual volume control from -15dB to +6dB, and the DAC volume can be adjusted in the digital domain if required. The output of these mixers is connected to the headphone outputs (LOUT1, ROUT1, LOUT2 and ROUT2) and can optionally be connected to the OUT3 and OUT4 mixers.

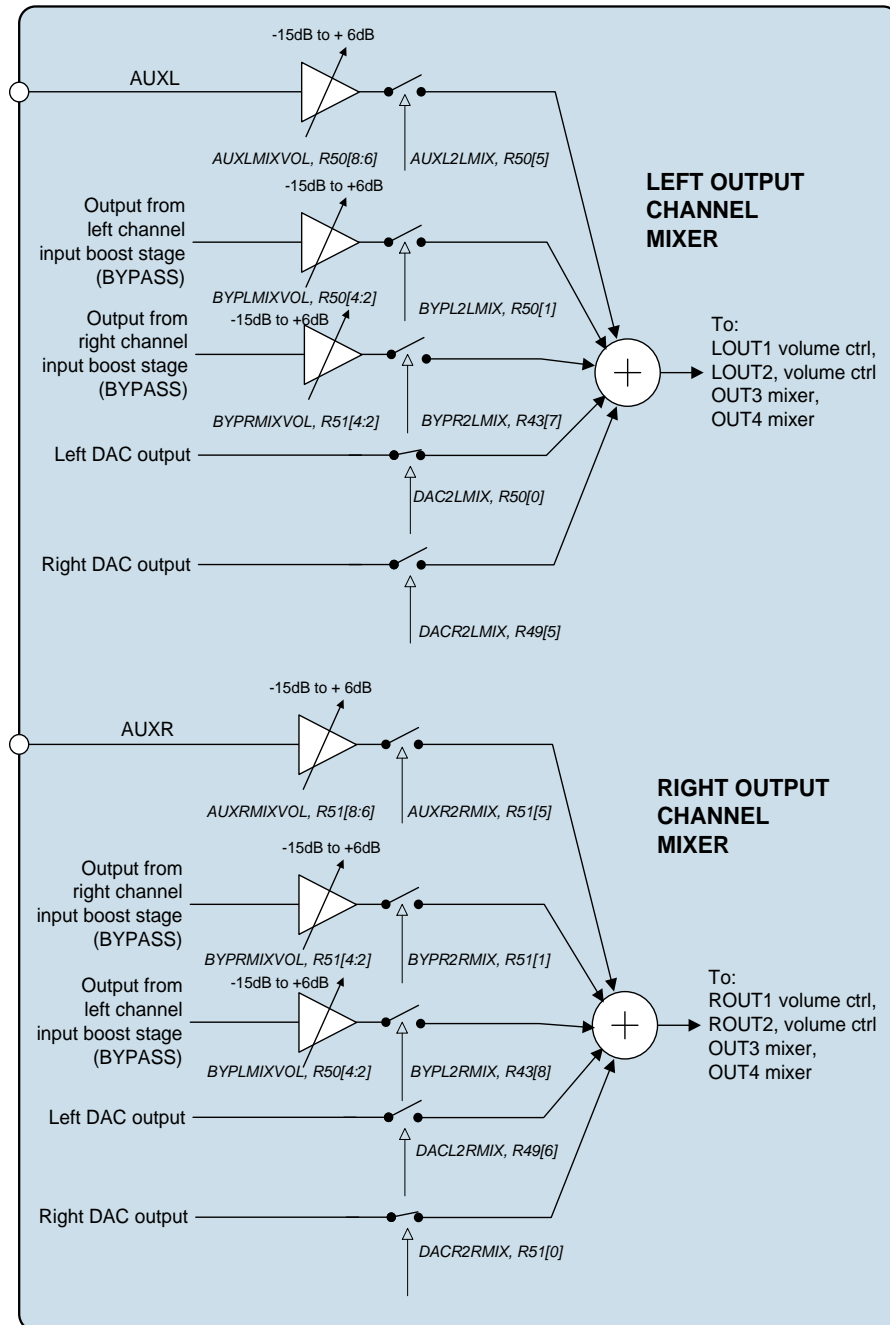

Figure 32 Left/Right Output Channel Mixers

REGISTER ADDRESS	BIT	LABEL	DEFAULT	DESCRIPTION
R43 Output mixer control	8	BYPL2RMIX	0	Left bypass path (from the Left channel input PGA stage) to right output mixer 0 = not selected 1 = selected
	7	BYPR2LMIX	0	Right bypass path (from the right channel input PGA stage) to Left output mixer 0 = not selected 1 = selected
R49 Output mixer control	5	DACR2LMIX	0	Right DAC output to left output mixer 0 = not selected 1 = selected
	6	DACL2RMIX	0	Left DAC output to right output mixer 0 = not selected 1 = selected
R50 Left channel output mixer control	0	DACL2LMIX	1	Left DAC output to left output mixer 0 = not selected 1 = selected
	1	BYPL2LMIX	0	Left bypass path (from the left channel input PGA stage) to left output mixer 0 = not selected 1 = selected
	4:2	BYPLMIXVOL	000	Left bypass volume control to output channel mixer: 000 = -15dB 001 = -12dB 010 = -9dB 011 = -6dB 100 = -3dB 101 = 0dB 110 = +3dB 111 = +6dB
	5	AUXL2LMIX	0	Left Auxiliary input to left channel output mixer: 0 = not selected 1 = selected
	8:6	AUXLMIXVOL	000	Aux left channel input to left mixer volume control: 000 = -15dB 001 = -12dB 010 = -9dB 011 = -6dB 100 = -3dB 101 = 0dB 110 = +3dB 111 = +6dB

REGISTER ADDRESS	BIT	LABEL	DEFAULT	DESCRIPTION
R51 Right channel output mixer control	0	DACR2RMIX	1	Right DAC output to right output mixer 0 = not selected 1 = selected
	1	BYPR2RMIX	0	Right bypass path (from the right channel input PGA stage) to right output mixer 0 = not selected 1 = selected
	4:2	BYPRMIXVOL	000	Right bypass volume control to output channel mixer: 000 = -15dB 001 = -12dB 010 = -9dB 011 = -6dB 100 = -3dB 101 = 0dB 110 = +3dB 111 = +6dB
	5	AUXR2RMIX	0	Right Auxiliary input to right channel output mixer: 0 = not selected 1 = selected
	8:6	AUXRMIXVOL	000	Aux right channel input to right mixer volume control: 000 = -15dB 001 = -12dB 010 = -9dB 011 = -6dB 100 = -3dB 101 = 0dB 110 = +3dB 111 = +6dB
R3 Power management 3	2	LMIXEN	0	Left output channel mixer enable: 0 = disabled 1 = enabled
	3	RMIXEN	0	Right output channel mixer enable: 0 = disabled 1 = enabled

Table 40 Left and Right Output Mixer Control

HEADPHONE OUTPUTS (LOUT1 AND ROUT1)

The headphone outputs LOUT1 and ROUT1 can drive a 16Ω or 32Ω headphone load, either through DC blocking capacitors, or DC-coupled to a buffered midrail reference as shown in Figure 33. OUT3, OUT4, LOUT2 or ROUT2 could be used as this buffered reference if one of these outputs is not being used, saving decoupling capacitors, at the expense of increased power consumption. For fully independent left and right channels, two separate midrail references can be used, eliminating crosstalk caused by headphone ground impedances, at the expense of increased power consumption.

Headphone Output using DC Blocking Capacitors:

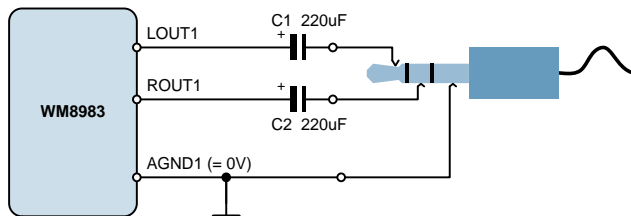

Lowest power consumption (Two outputs enabled);
Large and expensive capacitors;
Bass response may be reduced for smaller capacitors;
Impedance in common ground may introduce crosstalk.

DC Coupled Headphone Output:

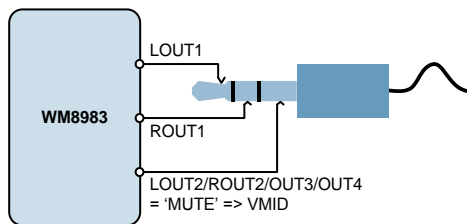

Higher power consumption (Three outputs enabled);
Improved PSRR if AVDD2 connected to AVDD1;
Impedance in common ground may introduce crosstalk;
Improved bass response (DC connection).

DC Coupled with Fully Independent Left / Right Drive:

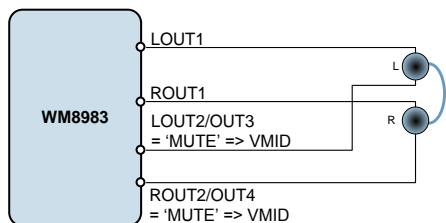

Highest power consumption (Four outputs enabled);
Improved PSRR if AVDD2 connected to AVDD1;
Independent L/R pseudo-ground eliminates crosstalk;
Improved bass response (DC connection);
Non-standard headphone connection may not be suitable for some applications.

Figure 33 Recommended Headphone Output Configurations

Each headphone output has an analogue volume control PGA with a gain range of -57dB to +6dB.

When DC blocking capacitors are used, their capacitance and the load resistance together determine the lower cut-off frequency of the output signal, f_c . Increasing the capacitance lowers f_c , improving the bass response. Smaller capacitance values will diminish the bass response. Assuming a 16Ω load and $C_1, C_2 = 220\mu\text{F}$:

$$f_c = 1 / 2\pi R_L C_1 = 1 / (2\pi \times 16\Omega \times 220\mu\text{F}) = 45 \text{ Hz}$$

In the DC coupled configuration, the headphone “ground” is connected to the VMID pin. The OUT3/4 pins can be configured as a DC output driver by setting the OUT3MUTE and OUT4MUTE register bit. The DC voltage on VMID in this configuration is equal to the DC offset on the LOUT1 and ROUT1 pins; therefore, no DC blocking capacitors are required. This saves space and material cost in portable applications.

Note that LOUT2, ROUT2, OUT3 and OUT4 have an optional output boost of 1.5x. When these are configured in this output boost mode (SPKBOOST/OUT3BOOST/OUT4BOOST=1), then the VMID value of these outputs will be equal to $1.5 \times \text{AVDD}/2$ and will not match the VMID of the headphone drivers. Do not use the DC coupled output mode in this configuration.

It is recommended to connect the DC coupled outputs only to headphones, and not to the line input of another device. Although the built-in short circuit protection will prevent any damage to the headphone outputs, such a connection may be noisy, and may not function properly if the other device is grounded.

REGISTER ADDRESS	BIT	LABEL	DEFAULT	DESCRIPTION
R52 LOUT1 Volume control	7	LOUT1ZC	0	Headphone volume zero cross enable: 1 = Change gain on zero cross only 0 = Change gain immediately
	6	LOUT1MUTE	0	Left headphone output mute: 0 = Normal operation 1 = Mute
	5:0	LOUT1VOL	111001	Left headphone output volume: 000000 = -57dB 000001 = -56dB ... 111001 = 0dB ... 111111 = +6dB
	8	OUT1VU	Not latched	LOUT1 and ROUT1 volumes do not update until a 1 is written to OUT1VU (in reg 52 or 53)
R53 ROUT1 Volume control	7	ROUT1ZC	0	Headphone volume zero cross enable: 1 = Change gain on zero cross only 0 = Change gain immediately
	6	ROUT1MUTE	0	Right headphone output mute: 0 = Normal operation 1 = Mute
	5:0	ROUT1VOL	111001	Right headphone output volume: 000000 = -57dB 000001 = -56dB ... 111001 = 0dB ... 111111 = +6dB
	8	OUT1VU	Not latched	LOUT1 and ROUT1 volumes do not update until a 1 is written to OUT1VU (in reg 52 or 53)

Table 41 OUT1 Volume Control

SPEAKER OUTPUTS (LOUT2 AND ROUT2)

The outputs LOUT2 and ROUT2 are designed to drive an 8Ω BTL speaker but can optionally drive two headphone loads of 16Ω/32Ω or a line output (see Headphone Output and Line Output sections, respectively). Each output has an individual volume control PGA, an output boost/level shift bit, a mute and an enable as shown in Figure 34. LOUT2 and ROUT2 output the left and right channel mixer outputs respectively.

The ROUT2 signal path also has an optional invert function; this is controlled using the INVROUT2 register bit.

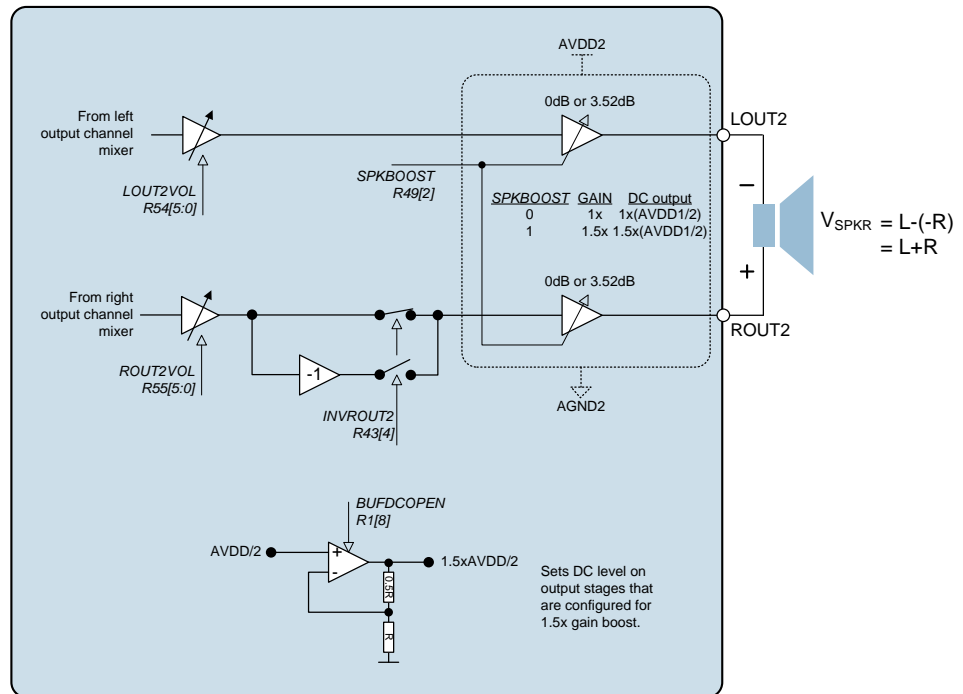
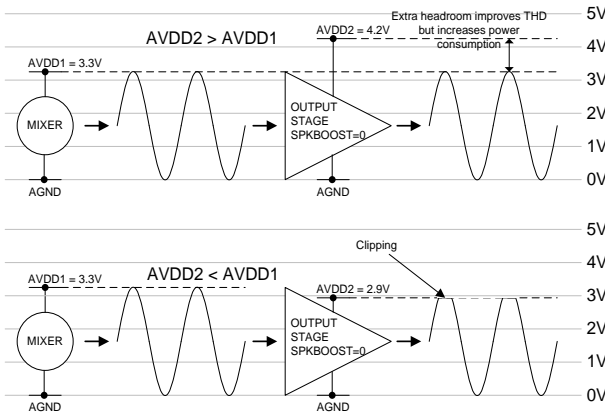
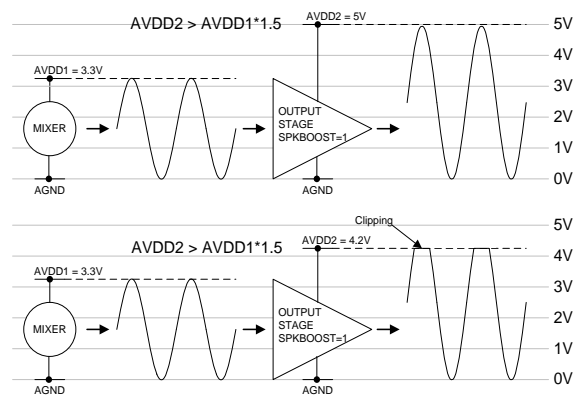

Figure 34 Speaker Outputs LOUT2 and ROUT2

SPEAKER BOOST MODE

To support speaker boost mode, AVDD2 should be at least 1.5*AVDD1. A higher AVDD2 will improve THD performance at the expense of power consumption while lower AVDD2 will cause clipping.

Variations in AVDD1 and AVDD2 should be taken into account when using speaker boost mode as shown in Figure 35 and Figure 36.

Figure 35 Non-Boost Mode Output Operation

Figure 36 Boost Mode Output Operation

LOUT2 and ROUT2 outputs can be connected directly to a Lithium battery to improve THD performance in non-boost mode. When using a 4.2V lithium battery, maximum power output is achieved without using speaker boost and by setting AVDD1 = 3.6V.

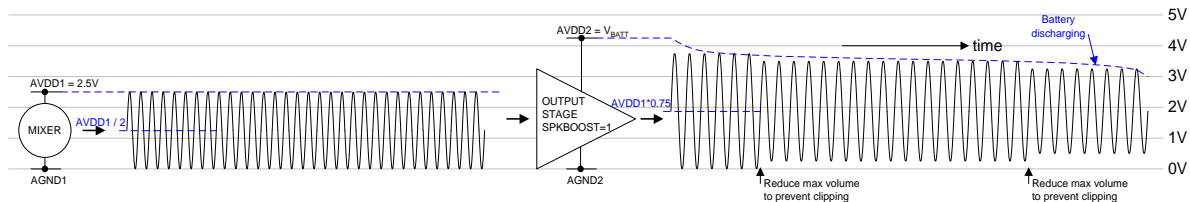
Although direct battery connection is also possible in boost mode, the discharge characteristic of the battery can lead to clipping after a relatively short period of time as shown in Figure 37. Reducing the maximum permitted volume and keeping AVDD1 to a minimum will allow boost mode to operate for longer.

Figure 37 Output Boost Mode with Direct Battery Connection

As the full scale output falls close to AVDD1, it becomes more effective to use non-boost mode to generate a louder output, although SPKBOOST should NOT be changed while the speaker output is driving out a signal. As a general rule:

if $AVDD2 - (AVDD1 * 0.75) > AVDD1 / 2$ boost mode provides more power output;

if $AVDD2 - (AVDD1 * 0.75) < AVDD1 / 2$ non-boost mode provides more power output.

REGISTER ADDRESS	BIT	LABEL	DEFAULT	DESCRIPTION
R54 LOUT2 Volume control	7	LOUT2ZC	0	Left speaker volume zero cross enable: 1 = Change gain on zero cross only 0 = Change gain immediately
	6	LOUT2MUTE	0	Left speaker output mute: 0 = Normal operation 1 = Mute
	5:0	LOUT2VOL	111001	Left speaker output volume: 000000 = -57dB 000001 = -56dB ... 111001 = 0dB ... 111111 = +6dB
	8	OUT2VU	Not latched	LOUT2 and ROUT2 volumes do not update until a 1 is written to OUT2VU (in reg 54 or 55)
R55 ROUT2 Volume control	7	ROUT2ZC	0	Right speaker volume zero cross enable: 1 = Change gain on zero cross only 0 = Change gain immediately
	6	ROUT2MUTE	0	Right speaker output mute: 0 = Normal operation 1 = Mute
	5:0	ROUT2VOL	111001	Right speaker output volume: 000000 = -57dB 000001 = -56dB ... 111001 = 0dB ... 111111 = +6dB
	8	OUT2VU	Not latched	LOUT2 and ROUT2 volumes do not update until a 1 is written to OUT2VU (in reg 54 or 55)

Table 42 OUT2 Volume Control

The signal output on LOUT2/ROUT2 comes from the Left/Right Mixer circuits and can be any combination of the DAC output, the Bypass path (output of the input boost stage) and the AUX input. The LOUT2/ROUT2 volume is controlled by the LOUT2VOL/ ROUT2VOL register bits. Gains over 0dB may cause clipping if the signal is large. The LOUT2MUTE/ ROUT2MUTE register bits cause the speaker outputs to be muted (the output DC level is driven out). The output pins remain at the same DC level (DCOP), so that no click noise is produced when muting or un-muting

The speaker output stages also have a selectable gain boost of 1.5x (3.52dB). When this boost is enabled, the output DC level is also level shifted (from AVDD1/2 to 1.5xAVDD1/2) to prevent the signal from clipping. A dedicated amplifier BUFDCOP, as shown in Figure 34, is used to perform the DC level shift operation. This buffer must be enabled using the BUFDCOPEN register bit for this operating mode. It should also be noted that if AVDD2 is not equal to or greater than 1.5xAVDD1 this boost mode may result in signals clipping. Table 44 summarises the effect of the SPKBOOST control bits.

REGISTER ADDRESS	BIT	LABEL	DEFAULT	DESCRIPTION
R49 Output control	2	SPKBOOST	0	Speaker Gain 0 = speaker gain = -1; DC = AVDD1 / 2 1 = speaker gain = +1.5; DC = 1.5 x AVDD1 / 2
R1 Power management 1	8	BUFDCOPEN	0	Output stage 1.5xAVDD/2 driver enable 0 = Buffer disabled 1 = Buffer enabled (required for 1.5x gain boost)

Table 43 Speaker Boost Stage Control

SPKBOOST	OUTPUT STAGE GAIN	OUTPUT DC LEVEL	OUTPUT STAGE CONFIGURATION
0	1x (0dB)	AVDD1/2	Inverting
1	1.5x (3.52dB)	1.5xAVDD1/2	Non-inverting

Table 44 Output Boost Stage Details

REGISTER ADDRESS	BIT	LABEL	DEFAULT	DESCRIPTION
R43 Beep control	4	INVROUT2	0	Invert ROUT2 output 0 = Not inverted 1 = Inverted

Table 45 ROUT2 Phase Invert Control

ZERO CROSS TIMEOUT

A zero-cross timeout function is provided so that if zero cross is enabled on the input or output PGAs, the gain will automatically update after a timeout period if a zero cross has not occurred. This is enabled by setting SLOWCLKEN. The timeout period is dependent on the clock input to the digital and is equal to $2^{21} * \text{SYSCLK period}$.

REGISTER ADDRESS	BIT	LABEL	DEFAULT	DESCRIPTION
R7 Additional Control	0	SLOWCLKEN	0	Slow clock enable. Used for both the jack insert detect debounce circuit and the zero cross timeout. 0 = slow clock disabled 1 = slow clock enabled

Table 46 Timeout Clock Enable Control

Note: SLOWCLKEN is also used for the jack insert detect debounce circuit

OUT3/OUT4 MIXERS AND OUTPUT STAGES

The OUT3/OUT4 pins provide an additional stereo line output, a mono output, or a pseudo ground connection for headphones. There is a dedicated analogue mixer for OUT3 and one for OUT4 as shown in Figure 38.

The OUT3 and OUT4 output stages are powered from AVDD2 and AGND2. These individually-controllable outputs also incorporate an optional 1.5x boost and level shifting stage.

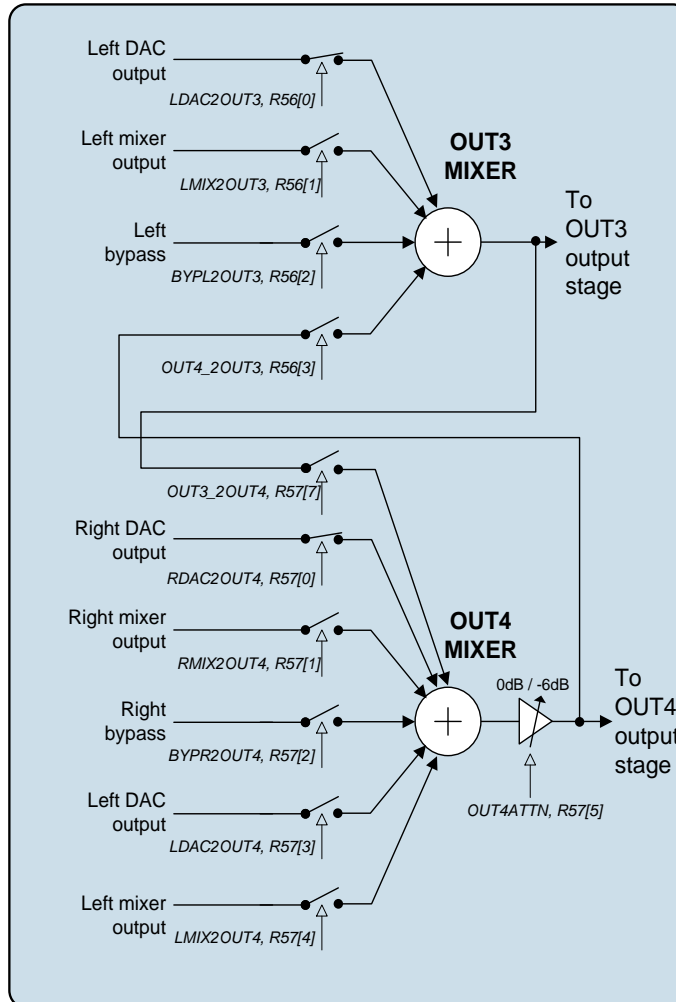

Figure 38 OUT3 and OUT4 Mixers

OUT3 can provide a midrail reference, a left line output, or a mono mix line output

OUT4 can provide a midrail reference, a right line output, or a mono mix line output.

A 6dB attenuation function is provided for OUT4, to prevent clipping during mixing of left and right signals. This function is enabled by the OUT4ATTN register bit.

REGISTER ADDRESS	BIT	LABEL	DEFAULT	DESCRIPTION
R1 Power Management 1	7	OUT4MIXEN	0	OUT4 mixer enable 0=disabled 1=enabled
	6	OUT3MIXEN	0	OUT3 mixer enable 0=disabled 1=enabled
R56 OUT3 mixer control	6	OUT3MUTE	0	0 = Output stage outputs OUT3 mixer 1 = Output stage muted – drives out VMID. Can be used as VMID reference in this mode.
	3	OUT4_2OUT3	0	OUT4 mixer output to OUT3 0 = disabled 1 = enabled
	2	BYPL2OUT3	0	Left ADC input to OUT3 0 = disabled 1 = enabled
	1	LMIX2OUT3	0	Left Output mixer to OUT3 0 = disabled 1 = enabled
	0	LDAC2OUT3	1	Left DAC output to OUT3 0 = disabled 1 = enabled
R57 OUT4 mixer control	7	OUT3_2OUT4	0	OUT3 mixer output to OUT4 0 = disabled 1 = enabled
	6	OUT4MUTE	0	0 = Output stage outputs OUT4 mixer 1 = Output stage muted – drives out VMID. Can be used as VMID reference in this mode.
	5	OUT4ATTN	0	0 = OUT4 normal output 1 = OUT4 attenuated by 6dB
	4	LMIX2OUT4	0	Left Output mixer to OUT4 0 = disabled 1 = enabled
	3	LDAC2OUT4	0	Left DAC to OUT4 0 = disabled 1 = enabled
	2	BYPR2OUT4	0	Right ADC input to OUT4 0 = disabled 1 = enabled
	1	RMIX2OUT4	0	Right Output mixer to OUT4 0 = disabled 1 = enabled
	0	RDAC2OUT4	1	Right DAC output to OUT4 0 = disabled 1 = enabled

Table 47 OUT3/OUT4 Mixer Registers

The OUT3 and OUT4 output stages each have a selectable gain boost of 1.5x (3.52dB). When this boost is enabled, the output DC level is also level shifted (from AVDD1/2 to 1.5xAVDD1/2) to prevent the signal from clipping. A dedicated amplifier BUFDCOP, as shown in Figure 39, is used to perform the DC level shift operation. This buffer must be enabled using the BUFDCOPEN register bit for this operating mode. It should also be noted that if AVDD2 is not equal to or greater than 1.5xAVDD1, this boost mode may result in signals clipping. Table 44 summarises the effect of the OUT3BOOST and

OUT4BOOST control bits.

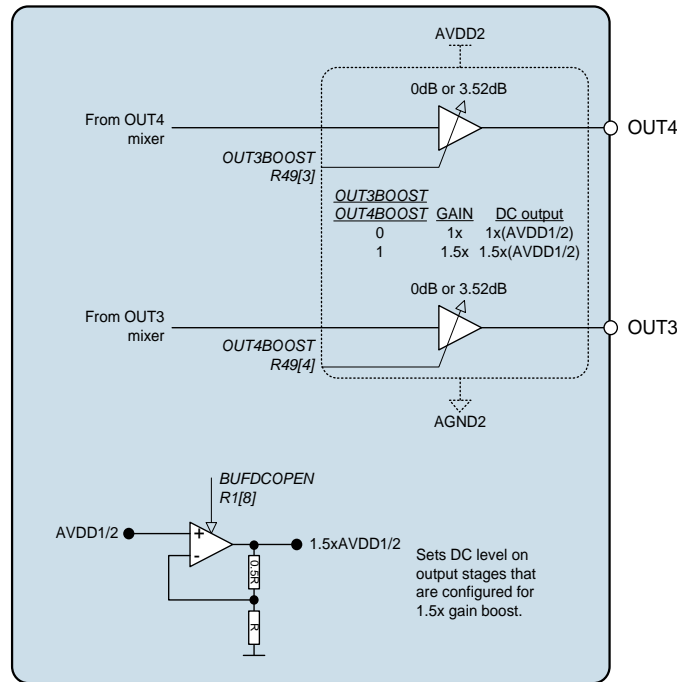
Figure 39 Outputs OUT3 and OUT4

REGISTER ADDRESS	BIT	LABEL	DEFAULT	DESCRIPTION
R49 Output control	3	OUT3BOOST	0	Output 3 Gain 0 = OUT3 output gain = -1; DC = AVDD1 / 2 1 = OUT3 output gain = +1.5 DC = 1.5 x AVDD1 / 2
	4	OUT4BOOST	0	Output 4 Gain 0 = OUT4 output gain = -1; DC = AVDD1 / 2 1 = OUT4 output gain = +1.5 DC = 1.5 x AVDD1 / 2
R1 Power management 1	8	BUFDCOPEN	0	Output stage 1.5xAVDD/2 driver enable 0=Buffer disabled 1=Buffer enabled (required for 1.5x gain boost)

Table 48 OUT3 and OUT4 Boost Stages Control

OUT3BOOST/ OUT4BOOST	OUTPUT STAGE GAIN	OUTPUT DC LEVEL	OUTPUT STAGE CONFIGURATIO N
0	1x	AVDD1/2	Inverting
1	1.5x	1.5xAVDD1/2	Non-inverting

Table 49 OUT3 and OUT4 Output Boost Stage Details

OUTPUT PHASING

The relative phases of the analogue outputs will depend upon the following factors:

1. DACLPOL and DACRPOL invert bits: Setting these bits to 1 will invert the DAC output.
2. Mixer configuration: The polarity of the signal will depend upon the route through the mixer path. For example, DACL can be directly input to the OUT3 mixer, giving a 180° phase shift at the OUT3 mixer output. However, if DACL is input to the OUT3 mixer via the left mixer, an additional phase shift will be introduced, giving 0° phase shift at the OUT3 mixer output.
3. Output boost set-up: When 1.5x boost is enabled on an output, no phase shift occurs. When 1.5x boost is not enabled, a 180° phase shift occurs.

Figure 32 shows where these phase inversions can occur in the output signal path.

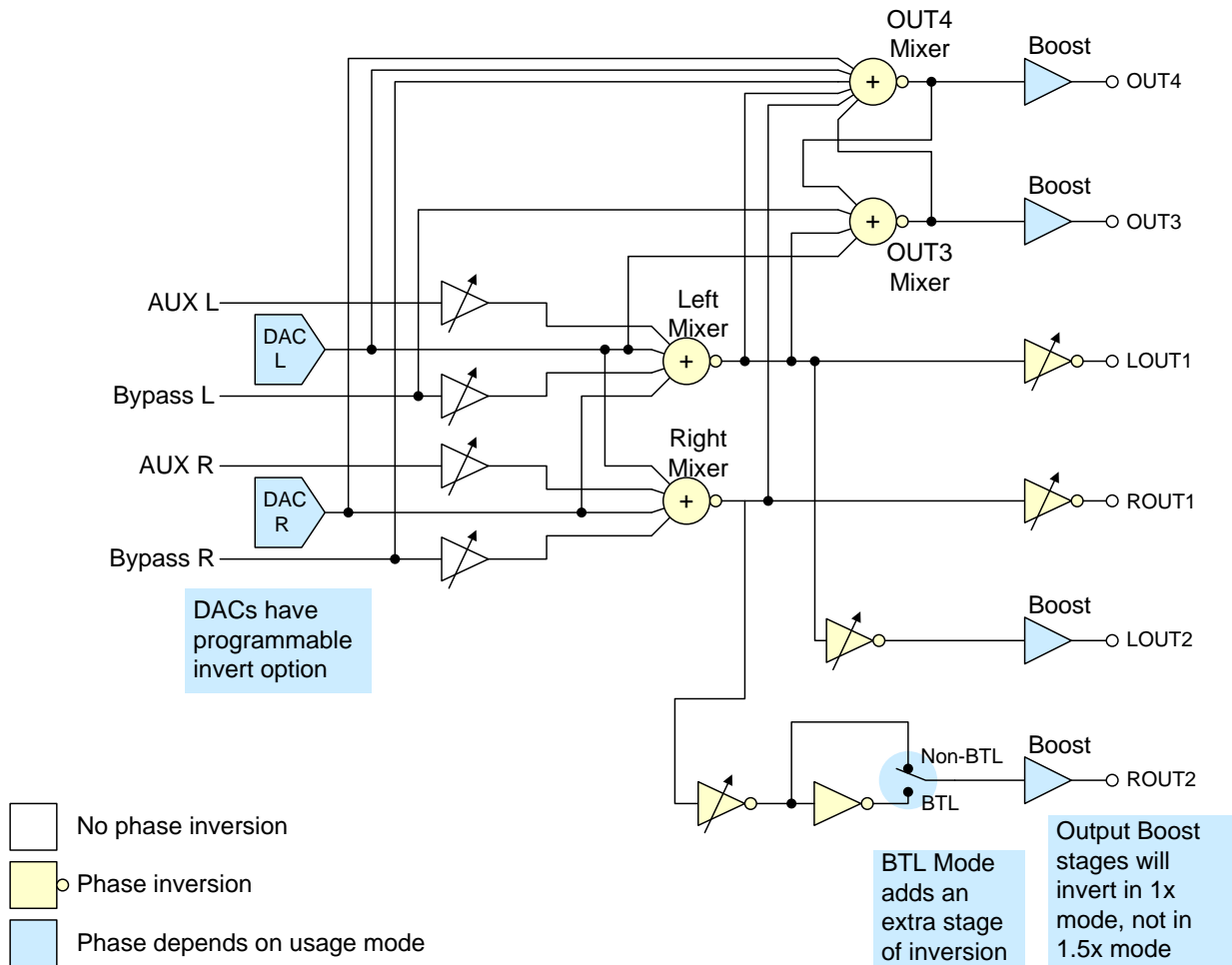

Figure 40 Output Signal Path Phasing

Table 50 shows the polarities of the outputs in various configurations.

Unless otherwise stated, polarity is shown with respect to left DAC output in non-inverting mode.

Note that only registers relating to the mixer paths are shown here (Mixer enables, volume settings, output enables etc are not shown).

CONFIGURATION	DACLPOL	DACRPOL	INVROUT2	SPKBOOST	OUT3BOOST	OUT4BOOST	MIXER PATH REGISTERS DIFFERENT FROM DEFAULT	OUT4 PHASE / MAG	OUT3 PHASE / MAG	LOUT1 PHASE / MAG	ROUT1 PHASE / MAG	LOUT2 PHASE / MAG	ROUT2 PHASE / MAG
Default: Stereo DAC playback to LOUT1/ROUT1, LOUT2/ROUT2 and OUT4/OUT3	0	0	0	0	0	0		0° 1	0° 1	0° 1	0° 1	180° 1	180° 1
DACs inverted	1	1	0	0	0	0		180° 1	180° 1	180° 1	180° 1	0° 1	0° 1
Stereo DAC playback to LOUT1/ROUT1 and LOUT2/ROUT2 and OUT4/OUT3 (Speaker boost enabled)	0	0	0	1	0	0		0° 1	0° 1	0° 1	0° 1	0° 1.5	0° 1.5
Stereo DAC playback to LOUT1/ROUT1 and LOUT2/ROUT2 and OUT4/OUT3 (OUT3 and OUT4 boost enabled)	0	0	0	0	1	1		180° 1.5	180° 1.5	0° 1	0° 1	180° 1	180° 1
Stereo playback to OUT3/OUT4 (DACs input to OUT3/OUT4 mixers via left/right mixers)	0	0	0	0	0	0	LDAC2OUT3=0 RDAC2OUT4=0 LMIX2OUT3=1 RMIX2OUT4=1	180° 1	180° 1	0° 1	0° 1	180° 1	180° 1
Differential output of right bypass path via OUT3/OUT4 (Phase shown relative to right bypass)	0	0	0	0	0	0	BYPR2OUT4=1 OUT4_2OUT3=1	180° 1	0° 1	X	X	X	X
Differential output of mono mix of DACs via LOUT2/ROUT2 (e.g. BTL speaker drive)	0	0	1	0	0	0		0° 1	0° 1	0° 1	0° 1	180° 1	0° 1
High power speaker drive	0	0	1	1	0	0		0° 1	0° 1	0° 1	0° 1	0° 1.5	180° 1.5

Table 50 Relative Output Phases

Note that differential output should not be set up by combining outputs in boost mode with outputs which are not in boost mode as this would cause a DC offset current on the outputs.

ENABLING THE OUTPUTS

Each analogue output of the WM8983 can be independently enabled or disabled. The analogue mixer associated with each output has a separate enable bit. All outputs are disabled by default. To save power, unused parts of the WM8983 should remain disabled.

Outputs can be enabled at any time, but it is not recommended to do so when BUFIO is disabled (BUFIOEN=0), as this may cause pop noise (see “Power Management” and “Applications Information” sections).

REGISTER ADDRESS	BIT	LABEL	DEFAULT	DESCRIPTION
R1 Power Management 1	2	BUFIOEN	0	Unused input/output bias buffer enable 0=disabled 1=enabled
	6	OUT3MIXEN	0	OUT3 mixer enable 0=disabled 1=enabled
	7	OUT4MIXEN	0	OUT4 mixer enable 0=disabled 1=enabled
	8	BUFDCOPEN	0	Output stage 1.5xAVDD/2 driver enable 0 = Buffer disabled 1 = Buffer enabled (required for 1.5x gain boost)
R2 Power Management 2	8	ROUT1EN	0	ROUT1 output enable 0=disabled 1=enabled
	7	LOUT1EN	0	LOUT1 output enable 0=disabled 1=enabled
	6	SLEEP	0	Sleep Mode enable 0 = Normal device operation 1 = Supply current reduced in device standby mode if clocks are still running
R3 Power Management 3	2	LMIXEN	0	Left output channel mixer enable 0 = disabled 1 = enabled
	3	RMIXEN	0	Right output channel mixer enable 0 = disabled 1 = enabled
	5	ROUT2EN	0	ROUT2 output enable 0 = disabled 1 = enabled
	6	LOUT2EN	0	LOUT2 output enable 0 = disabled 1 = enabled
	7	OUT3EN	0	OUT3 enable 0 = disabled 1 = enabled
	8	OUT4EN	0	OUT4 enable 0 = disabled 1 = enabled

R42 Output ctrl1	2	POBCTRL	0	Power-On Bias Control (Use during power Up. Reset when VMID bias is stable) 0 = Bias derived from VMID 1 = Bias derived from AVDD
	1	DELEN	0	2 nd enable bit for L/ROUT1
	0	OUT1DEL	0	2 stage enable for L/ROUT1

Table 51 Output Stages Power Management Control

OUT1DEL enables lower pop noise power-up option for LOUT1 and ROUT1. See Recommended Control Sequences (in 2 stage enable method, normal enable bit is set, followed shortly later by the delayed enable DELEN).

THERMAL SHUTDOWN

To protect the WM8983 from overheating, a thermal shutdown circuit is included. If the device temperature reaches approximately 125°C and the thermal shutdown circuit is enabled (TSDEN=1), the L/ROUT2 amplifiers will be disabled. The thermal shutdown may also be configured to generate an interrupt. See the GPIO and Interrupt Controller section for details.

REGISTER ADDRESS	BIT	LABEL	DEFAULT	DESCRIPTION
R49 Output Control	1	TSDEN	1	Thermal Shutdown Enable 0 : thermal shutdown disabled 1 : thermal shutdown enabled

Table 52 Thermal Shutdown

UNUSED ANALOGUE INPUTS/OUTPUTS

Whenever an analogue input/output is disabled, it remains connected to a voltage source (either AVDD1/2 or 1.5xAVDD1/2 as appropriate) through a resistor. This helps to prevent pop noise when the output is re-enabled. The resistance between the voltage buffer and the output pins can be controlled using the VROI control bit. The default impedance is low, so that any capacitors on the outputs can charge up quickly at start-up. If a high impedance is desired for disabled outputs, VROI can then be set to 1, increasing the resistance to about 30kΩ.

A dedicated buffer is available for biasing unused analogue I/O pins as shown in Figure 41. This buffer can be enabled using the BUFIOEN register bit.

If the SPKBOOST, OUT3BOOST or OUT4BOOST bits are set, then the relevant outputs will be tied to the output of the DC level shift buffer at 1.5xAVDD/2 when disabled.

REGISTER ADDRESS	BIT	LABEL	DEFAULT	DESCRIPTION
R1 Power Management 1	2	BUFIOEN	0	Unused input/output bias buffer enable 0=disabled 1=enabled
R49 Output Control	0	VROI	0	VREF (AVDD1/2 or 1.5xAVDD/2) to analogue output resistance 0: approx 1kΩ 1: approx 30 kΩ

Table 53 Disabled Outputs to VREF Resistance

Figure 41 summarises the bias options for the output pins.

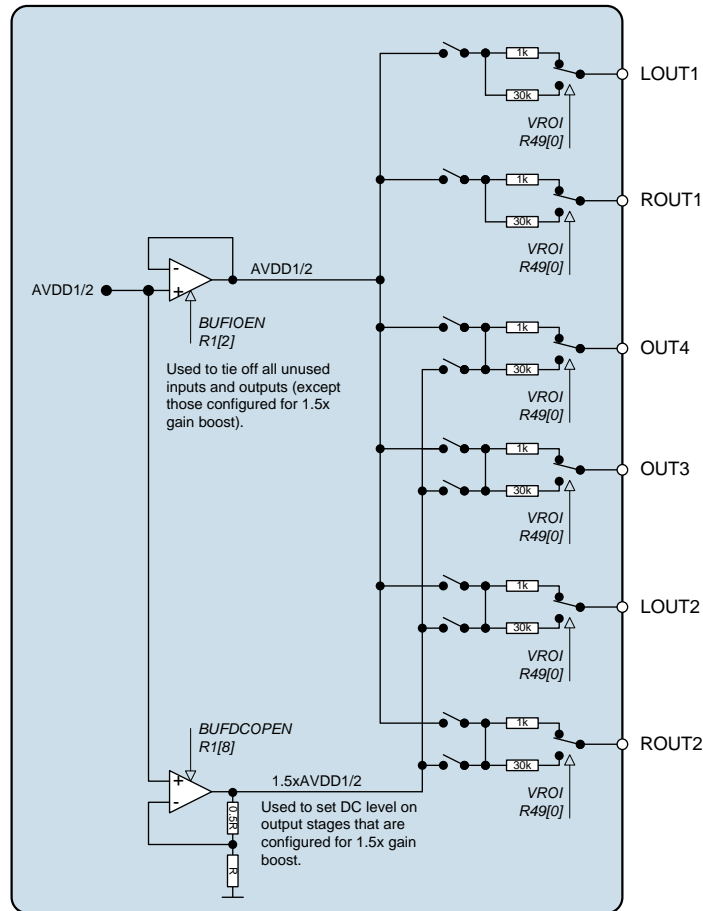
Figure 41 Unused Output Pin Tie-off Buffers

L/ROUT2EN/ OUT3/4EN	OUT3BOOST/ OUT4BOOST/ SPKBOOST	VROI	OUTPUT CONFIGURATION
0	0	0	1kΩ tie-off to AVDD1/2
0	0	1	30kΩ tie-off to AVDD1/2
0	1	0	1kΩ tie-off to 1.5xAVDD1/2
0	1	1	30kΩ tie-off to 1.5xAVDD1/2
1	0	X	Output enabled (DC level=AVDD1/2)
1	1	X	Output enabled (DC level=1.5xAVDD1/2)

Table 54 Unused Output Pin Bias Options

DIGITAL AUDIO INTERFACES

The audio interface has four pins:

- ADCDAT: ADC data output
- DACDAT: DAC data input
- LRC: Data Left/Right alignment clock
- BCLK: Bit clock, for synchronisation

The clock signals BCLK, and LRC can be outputs when the WM8983 operates as a master, or inputs when it is a slave (see Master and Slave Mode Operation, below).

Five different audio data formats are supported:

- Left justified
- Right justified
- I²S
- DSP mode early
- DSP mode late

All of these modes are MSB first. They are described in Audio Data Formats, below. Refer to the Electrical Characteristic section for timing information.

MASTER AND SLAVE MODE OPERATION

The WM8983 audio interface may be configured as either master or slave. As a master interface device, the WM8983 generates BCLK and LRC and thus controls sequencing of the data transfer on ADCDAT and DACDAT. To set the device to master mode, register bit MS should be set high. In slave mode (MS=0), the WM8983 responds with data to clocks it receives over the digital audio interfaces.

AUDIO DATA FORMATS

In Left Justified mode, the MSB is available on the first rising edge of BCLK following an LRC transition. The other bits up to the LSB are then transmitted in order. Depending on word length, BCLK frequency and sample rate, there may be unused BCLK cycles before each LRC transition.

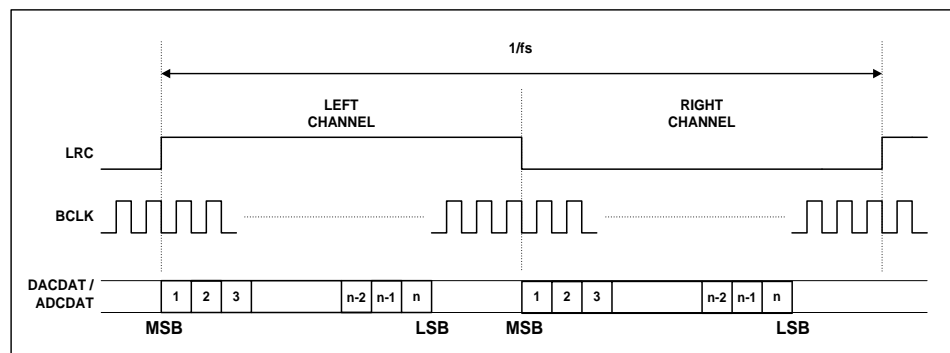

Figure 42 Left Justified Audio Interface (assuming n-bit word length)

In Right Justified mode, the LSB is available on the last rising edge of BCLK before a LRC transition. All other bits are transmitted before (MSB first). Depending on word length, BCLK frequency and sample rate, there may be unused BCLK cycles after each LRC transition.

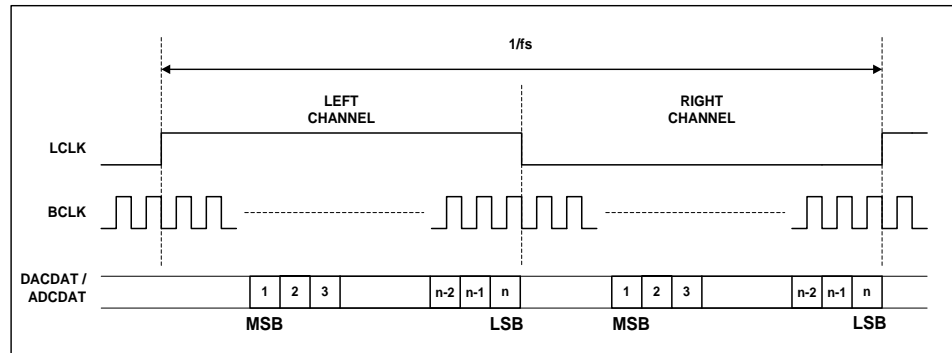

Figure 43 Right Justified Audio Interface (assuming n-bit word length)

In I²S mode, the MSB is available on the second rising edge of BCLK following a LRC transition. The other bits up to the LSB are then transmitted in order. Depending on word length, BCLK frequency and sample rate, there may be unused BCLK cycles between the LSB of one sample and the MSB of the next.

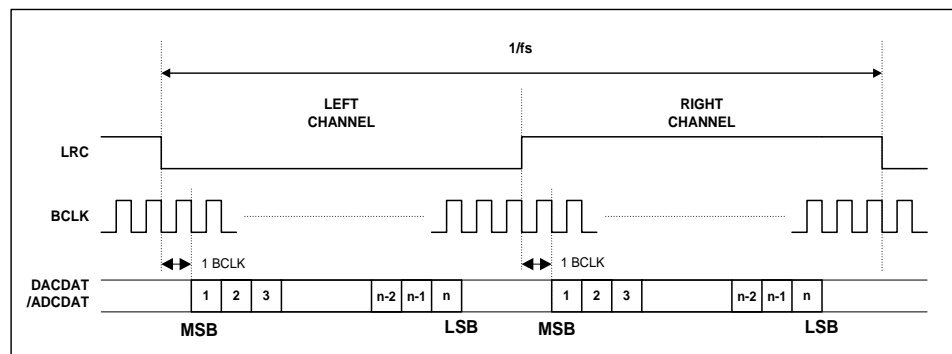

Figure 44 I²S Audio Interface (assuming n-bit word length)

In DSP/PCM mode, the left channel MSB is available on either the 1st (mode B) or 2nd (mode A) rising edge of BCLK (selectable by LRP) following a rising edge of LRC. Right channel data immediately follows left channel data. Depending on word length, BCLK frequency and sample rate, there may be unused BCLK cycles between the LSB of the right channel data and the next sample.

In device master mode, the LRC output will resemble the LRC pulse shown in Figure 45 and Figure 46. In device slave mode, shown in Figure 47 and Figure 48, it is possible to use any length of LRC pulse less than $1/f_s$, providing the falling edge of the LRC pulse occurs greater than one BCLK period before the rising edge of the next LRC pulse.

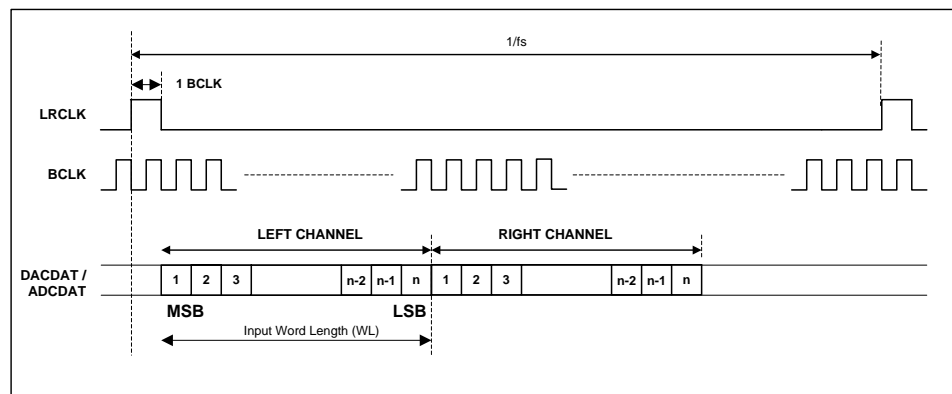

Figure 45 DSP/PCM Mode Audio Interface (mode A, LRP=0, Master)

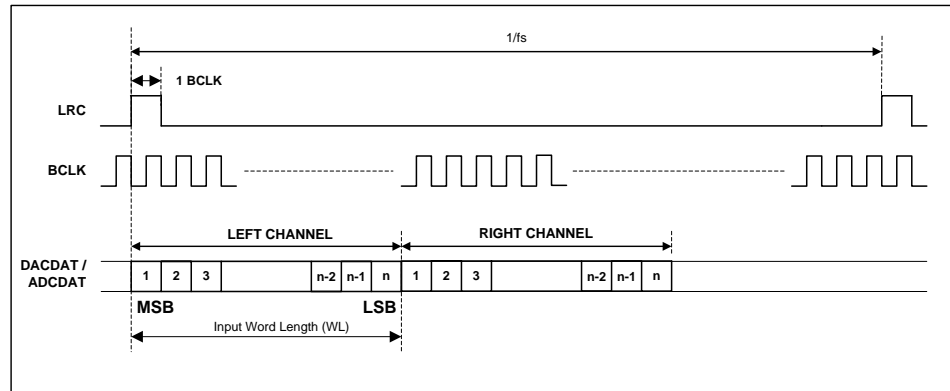

Figure 46 DSP/PCM Mode Audio Interface (mode B, LRP=1, Master)

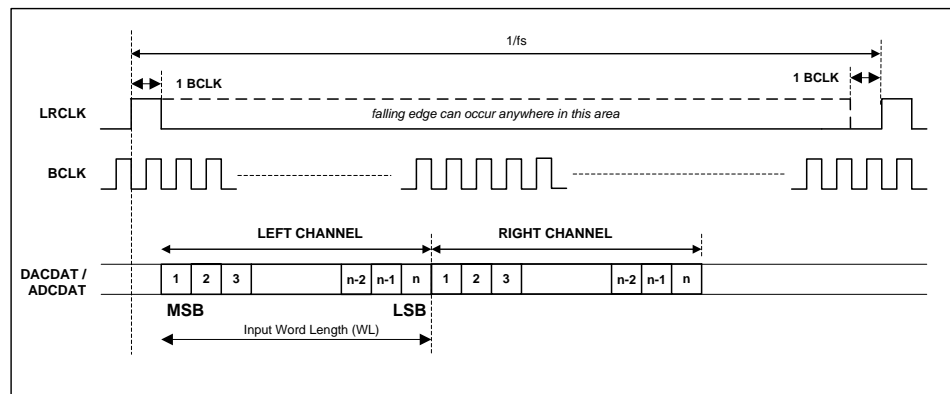

Figure 47 DSP/PCM Mode Audio Interface (mode A, LRP=0, Slave)

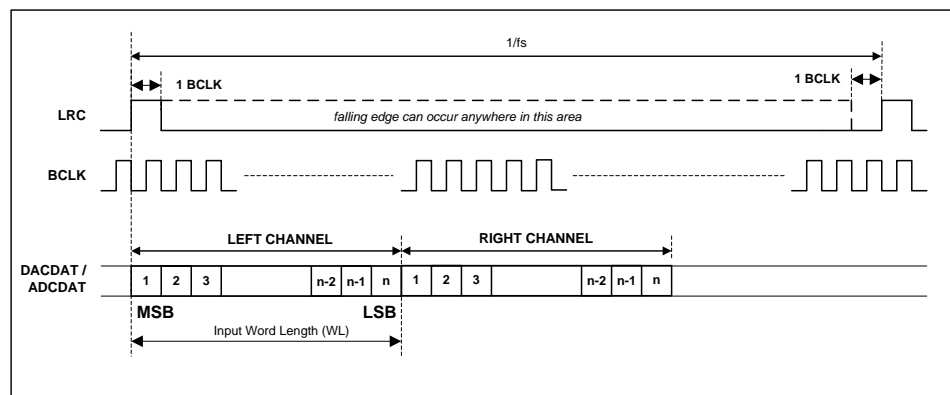

Figure 48 DSP/PCM Mode Audio Interface (mode B, LRP=0, Slave)

REGISTER ADDRESS	BIT	LABEL	DEFAULT	DESCRIPTION
R4 Audio Interface Control	0	MONO	0	Selects between stereo and mono device operation: 0 = Stereo device operation 1 = Mono device operation. Data appears in 'left' phase of LRC.
	1	ALRSWAP	0	Controls whether ADC data appears in 'right' or 'left' phases of LRC clock: 0=ADC left data appears in 'left' phase of LRC and right data in 'right' phase 1=ADC left data appears in 'right' phase of LRC and right data in 'left' phase
	2	DLRSWAP	0	Controls whether DAC data appears in 'right' or 'left' phases of LRC clock: 0=DAC left data appears in 'left' phase of LRC and right data in 'right' phase 1=DAC left data appears in 'right' phase of LRC and right data in 'left' phase
	4:3	FMT	10	Audio interface Data Format Select: 00=Right Justified 01=Left Justified 10=I ² S format 11= DSP/PCM mode
	6:5	WL	10	Word length 00=16 bits 01=20 bits 10=24 bits 11=32 bits (see note)
	7	LRP	0	LRC clock polarity 0=normal 1=inverted
	8	BCLP	0	BCLK polarity 0=normal 1=inverted
R5	0	LOOPBACK	0	Digital loopback function 0=No loopback 1=Loopback enabled, ADC data output is fed directly into DAC data input.

Table 55 Audio Interface Control

Note: Right Justified Mode will only operate with a maximum of 24 bits. If 32-bit mode is selected the device will operate in 24-bit mode.

AUDIO INTERFACE CONTROL

The register bits controlling audio format, word length and master / slave mode are summarised below.

Register bit MS selects audio interface operation in master or slave mode. In Master mode, BCLK and LRC are outputs. The frequencies of BCLK and LRC in master mode are controlled using MCLKDIV; these clocks are divided down versions of PLL output clock (SYSCLK). The MCLKDIV default setting provides a SYSCLK/256 division rate for the LRC output clock.

It is possible to divide down the BCLK rate using BCLKDIV; care must be taken in choosing the correct BCLKDIV rate to maintain sufficient BCLK pulses per LRC period for the chosen data word length. The BCLKDIV default setting provides a BCLK = SYSCLK clock.

REGISTER ADDRESS	BIT	LABEL	DEFAULT	DESCRIPTION
R6 Clock Generation Control	0	MS	0	Sets the chip to be master over LRC and BCLK 0=BCLK and LRC clock are inputs (Slave mode) 1=BCLK and LRC clock are outputs generated by the WM8983 (Master mode)
	4:2	BCLKDIV	000	Configures the BCLK and LRC output frequency, for use when the chip is in Master mode. 000=divide by 1 (BCLK=SYSCLK) 001=divide by 2 (BCLK=SYSCLK/2) 010=divide by 4 011=divide by 8 100=divide by 16 101=divide by 32 110=reserved 111=reserved
	7:5	MCLKDIV	010	Sets the division for either the MCLK or PLL clock output (selected by CLKSEL) 000=divide by 1 001=divide by 1.5 010=divide by 2 011=divide by 3 100=divide by 4 101=divide by 6 110=divide by 8 111=divide by 12
	8	CLKSEL	1	Controls the source of the clock for all internal operation: 0=MCLK 1=PLL output

Table 56 Clock Control

The CLKSEL bit selects the internal source of the Master clock from the PLL (CLKSEL=1) or from MCLK (CLKSEL=0). When the internal clock is switched from one source to another using the CLKSEL bit, the clock originally selected must generate at least one falling edge after the CLKSEL has changed for the switching of clocks to be successful. For example the sequence for switching between the PLL and MCLK should be:

1. Change CLKSEL 1 -> 0
2. Wait for at least one falling edge from PLL generated clock
3. Disable the PLL (PLLEN=0)

AUDIO SAMPLE RATES

The WM8983 filter characteristics for the ADCs and the DACs are set using the SR register bits; these bits do not change the rate of the audio interface output clocks in Master mode. The cut-offs for the digital filters and the ALC attack/decay times stated are determined using these values and assume a 256fs master clock rate.

If a sample rate is required which is not explicitly supported by the SR register settings, then the closest SR value to that sample rate should be chosen, and the filter characteristics and ALC attack, decay and hold times will scale appropriately.

REGISTER ADDRESS	BIT	LABEL	DEFAULT	DESCRIPTION
R7 Additional Control	3:1	SR	000	Approximate sample rate (configures the coefficients for the internal digital filters): 000 = 48kHz 001 = 32kHz 010 = 24kHz 011 = 16kHz 100 = 12kHz 101 = 8kHz 110-111 = reserved

Table 57 Sample Rate Control

MASTER CLOCK AND PHASE LOCKED LOOP (PLL)

The WM8983 has an on-chip phase-locked loop (PLL) circuit that can be used to:

- Generate master clocks for the WM8983 audio functions from another external clock, e.g. in telecoms applications.
- Generate and output (on pin CSB/GPIO1) a clock for another part of the system that is derived from an existing audio master clock.

Figure 49 shows the PLL and internal clocking on the WM8983.

The PLL can be enabled or disabled by the PLEN register bit.

REGISTER ADDRESS	BIT	LABEL	DEFAULT	DESCRIPTION
R1 Power management 1	5	PLEN	0	PLL enable 0 = PLL off 1 = PLL on

Table 58 PLEN Control Bit

REGISTER ADDRESS	BIT	LABEL	DEFAULT	DESCRIPTION
R36 PLL N value	4	PLLPRESCALE	0	0 = MCLK input not divided (default) 1 = Divide MCLK by 2 before input to PLL
	3:0	PLLN	1000	Integer (N) part of PLL input/output frequency ratio. Use values greater than 5 and less than 13.
R37 PLL K value 1	5:0	PLLK [23:18]	0Ch	Fractional (K) part of PLL1 input/output frequency ratio (treat as one 24-digit binary number).
R38 PLL K Value 2	8:0	PLLK [17:9]	093h	
R39 PLL K Value 3	8:0	PLLK [8:0]	0E9h	

Table 59 PLL Frequency Ratio Control

The PLL performs best when f_2 is around 90MHz. Its stability peaks at N=8. Some example settings are shown in Table 60.

MCLK (MHz) (F1)	DESIRED OUTPUT (MHz)	F2 (MHz)	PRESCALE DIVIDE	MCLKDIV	R	PLL N R36 (Hex)	K (Hex)	PLLK [23:18] R37 (Hex)	PLLK [17:9] R38 (Hex)	PLLK [8:0] R39 (Hex)
12	11.29	90.3168	1	2	7.5264	7	86C226	21	161	26
12	12.288	98.304	1	2	8.192	8	3126E8	C	93	E9
13	11.29	90.3168	1	2	6.947446	6	F28BD4	3C	145	1D4
13	12.288	98.304	1	2	7.561846	7	8FD525	23	1EA	126
14.4	11.29	90.3168	1	2	6.272	6	45A1CA	11	D0	1CA
14.4	12.288	98.304	1	2	6.826667	6	D3A06E	34	1D0	6D
19.2	11.29	90.3168	2	2	9.408	9	6872AF	1A	39	B0
19.2	12.288	98.304	2	2	10.24	A	3D70A3	F	B8	A3
19.68	11.29	90.3168	2	2	9.178537	9	2DB492	B	DA	92
19.68	12.288	98.304	2	2	9.990243	9	FD809F	3F	C0	9F
19.8	11.29	90.3168	2	2	9.122909	9	1F76F7	7	1BB	F8
19.8	12.288	98.304	2	2	9.929697	9	EE009E	3B	100	9E
24	11.29	90.3168	2	2	7.5264	7	86C226	21	161	26
24	12.288	98.304	2	2	8.192	8	3126E8	C	93	E9
26	11.29	90.3168	2	2	6.947446	6	F28BD4	3C	145	1D4
26	12.288	98.304	2	2	7.561846	7	8FD525	23	1EA	126
27	11.29	90.3168	2	2	6.690133	6	BOAC93	2C	56	94
27	12.288	98.304	2	2	7.281778	7	482296	12	11	96

Table 60 PLL Frequency Examples for Common MCLK Rates

LOOPBACK

Setting the LOOPBACK register bit enables digital loopback. When this bit is set, the output data from the ADC audio interface is fed directly into the DAC data input.

See Table 55 for register definition.

COMPANDING

The WM8983 supports A-law and μ -law companding on both transmit (ADC) and receive (DAC) sides. Companding can be enabled on the DAC or ADC audio interfaces by writing the appropriate value to the DAC_COMP or ADC_COMP register bits respectively.

REGISTER ADDRESS	BIT	LABEL	DEFAULT	DESCRIPTION
R5 Companding Control	2:1	ADC_COMP	0	ADC companding 00 = off 01 = reserved 10 = μ -law 11 = A-law
	4:3	DAC_COMP	0	DAC companding 00 = off 01 = reserved 10 = μ -law 11 = A-law
	5	WL8	0	0 = off 1 = device operates in 8-bit mode.

Table 61 Companding Control

Companding involves using a piecewise linear approximation of the following equations (as set out by ITU-T G.711 standard) for data compression:

μ -law (where $\mu=255$ for the U.S. and Japan):

$$F(x) = \ln(1 + \mu|x|) / \ln(1 + \mu) \quad -1 \leq x \leq 1$$

A-law (where $A=87.6$ for Europe):

$$F(x) = A|x| / (1 + \ln A) \quad \} \text{ for } x \leq 1/A$$

$$F(x) = (1 + \ln A|x|) / (1 + \ln A) \quad \} \text{ for } 1/A \leq x \leq 1$$

The companded data is also inverted as recommended by the G.711 standard (all 8 bits are inverted for μ -law, all even data bits are inverted for A-law). The data will be transmitted as the first 8 MSB's of data.

Companding converts 13 bits (μ -law) or 12 bits (A-law) to 8 bits using non-linear quantization. The input data range is separated into 8 levels, allowing low amplitude signals better precision than that of high amplitude signals. This is to exploit the operation of the human auditory system, where louder sounds do not require as much resolution as quieter sounds. The companded signal is an 8-bit word containing sign (1-bit), exponent (3-bits) and mantissa (4-bits).

Setting the WL8 register bit allows the device to operate with 8-bit data. In this mode, it is possible to use 8 BCLK's per LRC frame. When using DSP mode B, this allows 8-bit data words to be output consecutively every 8 BCLK's and can be used with 8-bit data words using the A-law and μ -law companding functions.

BIT7	BIT[6:4]	BIT[3:0]
SIGN	EXPONENT	MANTISSA

Table 62 8-bit Companded Word Composition

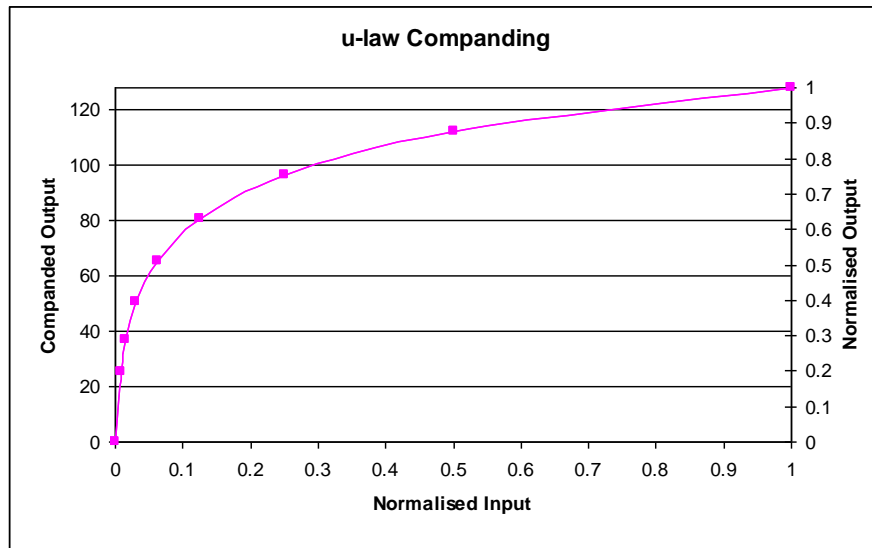

Figure 50 μ -Law Companding

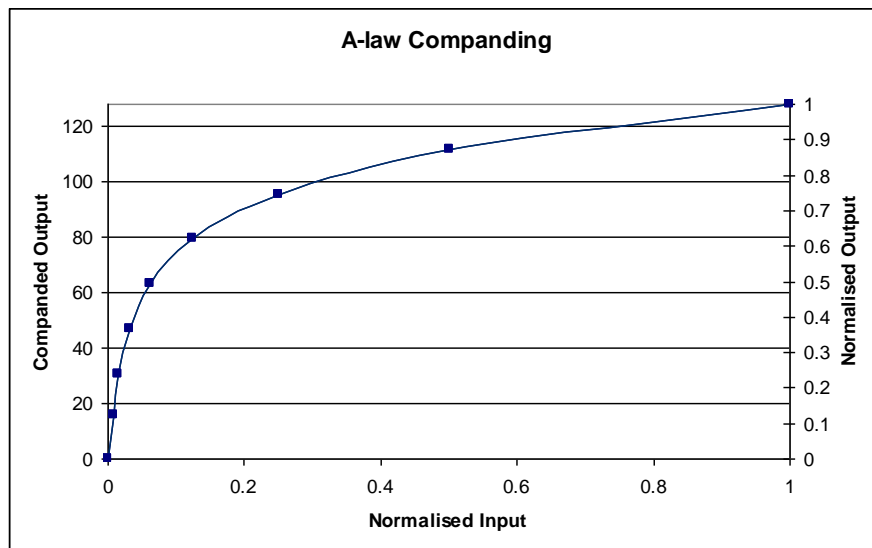

Figure 51 A-Law Companding

GENERAL PURPOSE INPUT/OUTPUT

The WM8983 has three dual purpose input/output pins.

- CSB/GPIO1: CSB / GPIO1 pin
- L2/GPIO2: Left channel line input / headphone detection input
- R2/GPIO3: Right channel line input / headphone detection input

The GPIO2 and GPIO3 functions are provided for use as jack detection inputs.

The GPIO1 and GPIO2 functions are provided for use as jack detection inputs or general purpose outputs.

The default configuration for the CSB/GPIO1 is to be an input.

When setup as an input, the CSB/GPIO1 pin can either be used as CSB or for jack detection, depending on how the MODE pin is set.

Table 63 illustrates the functionality of the GPIO1 pin when used as a general purpose output.

REGISTER ADDRESS	BIT	LABEL	DEFAULT	DESCRIPTION
R8 GPIO Control	2:0	GPIO1SEL	000	CSB/GPIO1 pin function select: 000= input (CSB/jack detection: depending on MODE setting) 001 = reserved 010 = Temp ok 011 = Amute active 100 = PLL clk output 101 = PLL lock 110 = logic 0 111 = logic 1
	3	GPIO1POL	0	GPIO1 Polarity invert 0 = Non inverted 1 = Inverted
	5:4	OPCLKDIV	00	PLL Output clock division ratio 00 = divide by 1 01 = divide by 2 10 = divide by 3 11 = divide by 4

Table 63 CSB/GPIO Control

Note: If MODE is set to 3 wire mode, CSB/GPIO1 is used as CSB input irrespective of the GPIO1SEL[2:0] bits.

For further details of the jack detect operation see the OUTPUT SWITCHING section.

OUTPUT SWITCHING (JACK DETECT)

When the device is operated using a 2-wire interface, the CSB/GPIO1 pin can be used as a switch control input to automatically disable one set of outputs and enable another; the most common use for this functionality is as jack detect circuitry. The L2/GPIO2 and R2/GPIO3 pins can also be used for this purpose.

The GPIO pins have an internal de-bounce circuit when in this mode in order to prevent the output enables from toggling multiple times due to input glitches. This de-bounce circuit is clocked from a slow clock with period $2^{21} \times \text{MCLK}$ and is enabled by the SLOWCLKEN bit.

Notes:

1. The SLOWCLKEN bit must be enabled for the jack detect circuitry to operate.
2. The GPIOPOL bit is not relevant for jack detection; it is the signal detected at the pin which is used.

Switching on/off of the outputs is fully configurable by the user. Each output, OUT1, OUT2, OUT3 and OUT4 has 2 associated enables. OUT1_EN_0, OUT2_EN_0, OUT3_EN_0 and OUT4_EN_0 are the output enable signals which are used if the selected jack detection pin is at logic 0 (after de-bounce). OUT1_EN_1, OUT2_EN_1, OUT3_EN_1 and OUT4_EN_1 are the output enable signals which are used if the selected jack detection pin is at logic 1 (after de-bounce).

The jack detection enables operate as follows:

All OUT_EN signals have an AND function performed with their normal enable signals (in Table 51). When an output is normally enabled at per Table 51, the selected jack detection enable (controlled by selected jack detection pin polarity) is set 0; it will turn the output off. If the normal enable signal is already OFF (0), the jack detection signal will have no effect due to the AND function.

During jack detection if the user desires an output to be un-changed whether the jack is in or not, both the JD_EN settings, i.e. JD_EN0 and JD_EN1, should be set to 0000.

If jack detection is not enabled (JD_EN=0), the output enables default to all 1's, allowing the outputs to be controlled as normal via the normal output enables found in Table 51.

REGISTER ADDRESS	BIT	LABEL	DEFAULT	DESCRIPTION
R9 (09h) GPIO control	5:4	JD_SEL	00	Pin selected as jack detection input 00 = GPIO1 01 = GPIO2 10 = GPIO3 11 = Reserved
	6	JD_EN	0	Jack Detection Enable 0 = disabled 1 = enabled
R13 (0Dh) Jack Detect Control	3:0	JD_EN0	0000	Output enables when selected jack detection input is logic 0. [0]= OUT1_EN_0 [1]= OUT2_EN_0 [2]= OUT3_EN_0 [3]= OUT4_EN_0
	7:4	JD_EN1	0000	Output enables when selected jack detection input is logic 1 [4]= OUT1_EN_1 [5]= OUT2_EN_1 [6]= OUT3_EN_1 [7]= OUT4_EN_1

Table 64 Jack Detect Register Control Bits

CONTROL INTERFACE

SELECTION OF CONTROL MODE AND 2-WIRE MODE ADDRESS

The control interface can operate as either a 3-wire or 2-wire control interface. The MODE pin determines the 2 or 3 wire mode as shown in Table 65.

The WM8983 is controlled by writing to registers through a serial control interface. A control word consists of 16 bits. The first 7 bits (B15 to B9) are register address bits that select which control register is accessed. The remaining 9 bits (B8 to B0) are data bits, corresponding to the 9 data bits in each control register.

MODE	INTERFACE FORMAT
Low	2 wire
High	3 wire

Table 65 Control Interface Mode Selection

3-WIRE SERIAL CONTROL MODE

In 3-wire mode, every rising edge of SCLK clocks in one data bit from the SDIN pin. A rising edge on CSB/GPIO latches in a complete control word consisting of the last 16 bits.

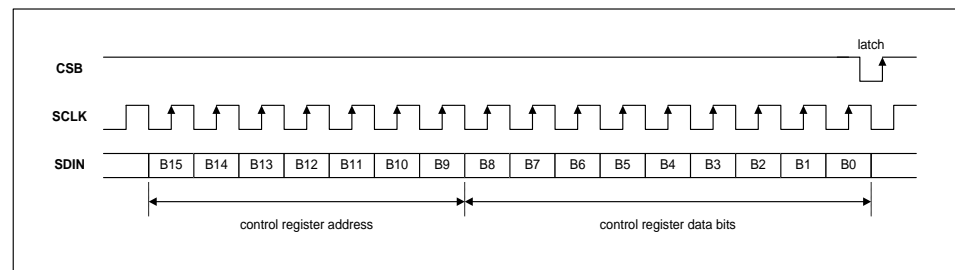

Figure 52 3-Wire Serial Control Interface

2-WIRE SERIAL CONTROL MODE

The WM8983 supports software control via a 2-wire serial bus. Many devices can be controlled by the same bus, and each device has a unique 7-bit device address (this is not the same as the 7-bit address of each register in the WM8983).

The WM8983 operates as a slave device only. The controller indicates the start of data transfer with a high to low transition on SDIN while SCLK remains high. This indicates that a device address and data will follow. All devices on the 2-wire bus respond to the start condition and shift in the next eight bits on SDIN (7-bit address + Read/Write bit, MSB first). If the device address received matches the address of the WM8983, the WM8983 responds by pulling SDIN low on the next clock pulse (ACK). If the address is not recognised or the R/W bit is '1' when operating in write only mode, the WM8983 returns to the idle condition and waits for a new start condition and valid address.

During a write, once the WM8983 has acknowledged a correct address, the controller sends the first byte of control data (B15 to B8, i.e. the WM8983 register address plus the first bit of register data). The WM8983 then acknowledges the first data byte by driving SDIN low for one clock cycle. The controller then sends the second byte of control data (B7 to B0, i.e. the remaining 8 bits of register data), and the WM8983 acknowledges again by pulling SDIN low.

Transfer is complete when there is a low to high transition on SDIN while SCLK is high. After a complete sequence, the WM8983 returns to the idle state and waits for another start condition. If a start or stop condition is detected out of sequence at any point during data transfer (i.e. SDIN changes while SCLK is high), the control interface returns to the idle condition.

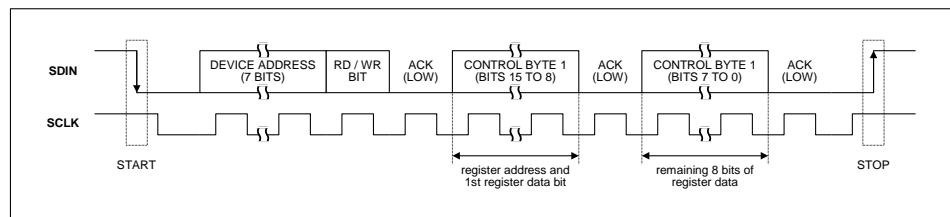

Figure 53 2-Wire Serial Control Interface

In 2-wire mode the WM8983 has a fixed device address, 0011010.

RESETTING THE CHIP

The WM8983 can be reset by performing a write of any value to the software reset register (address 0h). This will cause all register values to be reset to their default values. In addition to this there is a Power-On Reset (POR) circuit which ensures that the registers are initially set to default when the device is powered up.

POWER SUPPLIES

The WM8983 requires four separate power supplies:

AVDD1 and AGND1: Analogue supply, powers all internal analogue functions and output drivers LOUT1 and ROUT1. AVDD1 must be between 2.5V and 3.6V and has the most significant impact on overall power consumption (except for power consumed in the headphones). Higher AVDD1 will improve audio quality.

AVDD2 and AGND2: Output driver supplies, power LOUT2, ROUT2, OUT3 and OUT4. AVDD2 must be between 2.5V and 5.5V. AVDD2 can be tied to AVDD1, but it requires separate layout and decoupling capacitors to curb harmonic distortion.

DCVDD: Digital core supply, powers all digital functions except the audio and control interfaces. DCVDD must be between 1.71V and 3.6V, and has no effect on audio quality. The return path for DCVDD is DGND, which is shared with DBVDD.

DBVDD must be between 1.71V and 3.6V. DBVDD return path is through DGND.

It is possible to use the same supply voltage for all four supplies. However, digital and analogue supplies should be routed and decoupled separately on the PCB to keep digital switching noise out of the analogue signal paths.

POWER MANAGEMENT
SAVING POWER BY REDUCING OVERSAMPLING RATE

The default mode of operation of the ADC and DAC digital filters is in 64x oversampling mode. Under the control of ADCOSR128 and DACOSR128, the oversampling rate may be doubled. 64x oversampling results in a slight decrease in noise performance compared to 128x but lowers the power consumption of the device.

REGISTER ADDRESS	BIT	LABEL	DEFAULT	DESCRIPTION
R10 DAC control	3	DACOSR128	0	DAC oversample rate select 0 = 64x (lowest power) 1 = 128x (best performance)
R14 ADC control	3	ADCOSR128	0	ADC oversample rate select 0 = 64x (lowest power) 1 = 128x (best performance)

Table 66 ADC and DAC Oversampling Rate Selection
VMID

The analogue circuitry will not operate unless VMID is enabled. The impedance of the VMID resistor string, together with the decoupling capacitor on the VMID pin will determine the start-up time of the VMID circuit.

REGISTER ADDRESS	BIT	LABEL	DEFAULT	DESCRIPTION
R1 Power management 1	1:0	VMIDSEL	00	Reference string impedance to VMID pin (Determines startup time): 00 = off (250kΩ VMID to AGND1) 01 = 100kΩ 10 = 500kΩ 11 = 10kΩ total (for fast start-up)

Table 67 VMID Impedance Control
BIASEN

The analogue amplifiers will not operate unless BIASEN is enabled.

REGISTER ADDRESS	BIT	LABEL	DEFAULT	DESCRIPTION
R1 Power management 1	3	BIASEN	0	Analogue amplifier bias control 0 = disabled 1 = enabled

Table 68 Analogue Bias Control
BIAS CONTROL

Control of the analog bias values is possible using BIASCUT.

REGISTER ADDRESS	BIT	LABEL	DEFAULT	DESCRIPTION
R61 Bias control	8	BIASCUT	0	Global bias control 0 = normal 1 = 0.5x
	7:0		000 0000	Reserved

Table 69 Analogue Bias Control

REGISTER MAP

ADDR B[15:9]		REGISTER NAME	B8	B7	B6	B5	B4	B3	B2	B1	B0	DEF'T VAL	
D E C	H E X											(HEX)	
0	00	Software Reset	RESET										
1	01	Power manage't 1	BUFDC OPEN	OUT4 MIXEN	OUT3 MIXEN	PLLEN	MICBEN	BIASEN	BUFIO EN	VMIDSEL[1:0]		000	
2	02	Power manage't 2	ROUT1 EN	LOUT1 EN	SLEEP	BOOST ENR	BOOST ENL	INPPGA ENR	INPPGA ENL	ADC ENR	ADC ENL	000	
3	03	Power manage't 3	OUT4EN	OUT3EN	LOUT2 EN	ROUT2 EN	0	RMIXEN	LMIXEN	DAC ENR	DAC ENL	000	
4	04	Audio Interface	BCP	LRP	WL[1:0]		FMT[1:0]		DLR SWAP	ALR SWAP	MONO	050	
5	05	Companding ctrl	0	0	0	WL8	DAC_COMP[1:0]		ADC_COMP[1:0]		LOOP BACK	000	
6	06	Clock Gen ctrl	CLKSEL	MCLKDIV[2:0]			BCLKDIV[2:0]			0	MS	140	
7	07	Additional ctrl	0	0	0	0	0	SR[2:0]			SLOW CLKEN	000	
8	08	GPIO Control	0	0	0	OPCLKDIV[1:0]		GPIO1P OL	GPIO1SEL[2:0]			000	
9	09	Jack detect control	0	0	JD_EN	JD_SEL[1:0]		0	0	0	0	000	
10	0A	DAC Control	0	0	SOFT MUTE	0	0	DAC OSR128	AMUTE	DACR POL	DACL POL	000	
11	0B	Left DAC digital Vol	DACVU	DACLVOL[7:0]									OFF
12	0C	Right DAC dig'l Vol	DACVU	DACRVOL[7:0]									OFF
13	0D	Jack Detect Control	0	JD_EN1[3:0]				JD_EN0[3:0]				000	
14	0E	ADC Control	HPFEN	HPFAPP	HPFCUT[2:0]			ADC OSR128	0	ADCR POL	ADC LPOL	100	
15	0F	Left ADC Digital Vol	ADCVU	ADCLVOL[7:0]									OFF
16	10	Right ADC Digital Vol	ADCVU	ADCRVOL[7:0]									OFF
18	12	EQ1 – low shelf	EQ3D MODE	0	EQ1C[1:0]		EQ1G[4:0]				12C		
19	13	EQ2 – peak 1	EQ2BW	0	EQ2C[1:0]		EQ2G[4:0]				02C		
20	14	EQ3 – peak 2	EQ3BW	0	EQ3C[1:0]		EQ3G[4:0]				02C		
21	15	EQ4 – peak 3	EQ4BW	0	EQ4C[1:0]		EQ4G[4:0]				02C		
22	16	EQ5 – high shelf	0	0	EQ5C[1:0]		EQ5G[4:0]				02C		
24	18	DAC Limiter 1	LIMEN	LIMDCY[3:0]				LIMATK[3:0]				032	
25	19	DAC Limiter 2	0	0	LIMLVL[2:0]			LIMBOOST[3:0]				000	
27	1B	Notch Filter 1	NFU	NFEN	NFA0[13:7]							000	
28	1C	Notch Filter 2	NFU	0	NFA0[6:0]							000	
29	1D	Notch Filter 3	NFU	0	NFA1[13:7]							000	
30	1E	Notch Filter 4	NFU	0	NFA1[6:0]							000	
32	20	ALC control 1	ALCSEL		0	ALCMAx[2:0]			ALCMIN[2:0]			038	
33	21	ALC control 2	0	ALCHLD[3:0]				ALCLVL[3:0]				00B	
34	22	ALC control 3	ALC MODE	ALCDCY[3:0]				ALCATK[3:0]				032	
35	23	Noise Gate	0	0	0	0	0	NGEN	NGTH[2:0]			000	

ADDR B[15:9]		REGISTER NAME	B8	B7	B6	B5	B4	B3	B2	B1	B0	DEF'T VAL
D E C	H E X											(HEX)
36	24	PLL N	0	0	0	0	PLLPRE SCALE	PLLK[3:0]			008	
37	25	PLL K 1	0	0	0	PLLK[23:18]					00C	
38	26	PLL K 2	PLLK[17:9]									093
39	27	PLL K 3	PLLK[8:0]									0E9
41	29	3D control	0	0	0	0	0	DEPTH3D[3:0]			000	
42	2A	OUT4 to ADC	OUT4_2ADCVOL[2:0]			OUT4_2 LNR	0	0	POB CTRL	DELEN	OUT1 DEL	000
43	2B	Beep control	BYPL2 RMIX	BYPR2 LMIX	0	0	INV ROUT2	0	0	0	000	
44	2C	Input ctrl	MBVSEL	0	R2_2 INPPGA	RIN2 INPPGA	RIP2 INPPGA	0	L2_2 INPPGA	LIN2 INPPGA	LIP2 INPPGA	033
45	2D	Left INP PGA gain ctrl	INPGAVU	INPPGA ZCL	INPPGA MUTEL	INPPGAVOLL[5:0]					010	
46	2E	Right INP PGA gain ctrl	INPGAVU	INPPGA ZCR	INPPGA MUTER	INPPGAVOLR[5:0]					010	
47	2F	Left ADC Boost ctrl	PGA BOOSTL	0	L2_2BOOSTVOL[2:0]		0	AUXL2BOOSTVOL[2:0]			100	
48	30	Right ADC Boost ctrl	PGA BOOSTR	0	R2_2BOOSTVOL[2:0]		0	AUXR2BOOSTVOL[2:0]			100	
49	31	Output ctrl	0	0	DACL2 RMIX	DACR2 LMIX	OUT4 BOOST	OUT3 BOOST	SPK BOOST	TSDEN	VROI	002
50	32	Left mixer ctrl	AUXLMIXVOL[2:0]			AUXL2 LMIX	BYPLMIXVOL[2:0]			BYPL2 LMIX	DACL2 LMIX	001
51	33	Right mixer ctrl	AUXRMIXVOL[2:0]			AUXR2 RMIX	BYPRMIXVOL[2:0]			BYPR2 RMIX	DACR2 RMIX	001
52	34	LOUT1 (HP) volume ctrl	OUT1VU	LOUT1 ZC	LOUT1 MUTE	LOUT1VOL[5:0]					039	
53	35	ROUT1 (HP) volume ctrl	OUT1VU	ROUT1 ZC	ROUT1 MUTE	ROUT1VOL[5:0]					039	
54	36	LOUT2 (SPK) volume ctrl	OUT2VU	LOUT2 ZC	LOUT2 MUTE	LOUT2VOL[5:0]					039	
55	37	ROUT2 (SPK) volume ctrl	OUT2VU	ROUT2 ZC	ROUT2 MUTE	ROUT2VOL[5:0]					039	
56	38	OUT3 mixer ctrl	0	0	OUT3 MUTE	0	0	OUT4_2OUT3	BYPL2 OUT3	LMIX2 OUT3	LDAC2 OUT3	001
57	39	OUT4 (MONO) mixer ctrl	0	OUT3_2 OUT4	OUT4 MUTE	OUT4 ATTN	LMIX2 OUT4	LDAC2 OUT4	BYPR2 OUT4	RMIX2 OUT4	RDAC2 OUT4	001
59	3B	ALC Test Mode	0	0	0	0	0	0	0	ALCTST[1:0]		000
61	3D	Bias Control	BIASCUT	0	0	0	0	0	0	0	0	000

Table 70 WM8983 Register Map

REGISTER BITS BY ADDRESS
Notes:

1. Default values of N/A indicate non-latched data bits (e.g. software reset or volume update bits).
2. Register bits marked "Reserved" should not be changed from the default.

REGISTER ADDRESS	BIT	LABEL	DEFAULT	DESCRIPTION	REFER TO
0 (00h)	[8:0]	RESET	N/A	Software reset	Resetting the Chip
1 (01h)	8	BUFDCOPEN	0	Output stage 1.5xAVDD/2 driver enable 0 = Buffer disabled 1 = Buffer enabled (required for 1.5x gain boost)	Analogue Outputs
	7	OUT4MIXEN	0	OUT4 mixer enable 0=disabled 1=enabled	Power Management
	6	OUT3MIXEN	0	OUT3 mixer enable 0=disabled 1=enabled	Power Management
	5	PLLEN	0	PLL enable 0=PLL off 1=PLL on	Master Clock and Phase Locked Loop (PLL)
	4	MICBEN	0	Microphone Bias Enable 0 = OFF (high impedance output) 1 = ON	Input Signal Path
	3	BIASEN	0	Analogue amplifier bias control 0=disabled 1=enabled	Power Management
	2	BUFIOEN	0	Unused input/output tie off buffer enable 0=disabled 1=enabled	Power Management
	1:0	VMIDSEL	00	Reference string impedance to VMID pin (Determines startup time): 00 = off (250kΩ VMID to AGND1) 01 = 100kΩ 10 = 500kΩ 11 = 10kΩ total (for fast start-up)	Power Management
2 (02h)	8	ROUT1EN	0	ROUT1 output enable 0=disabled 1=enabled	Power Management
	7	LOUT1EN	0	LOUT1 output enable 0=disabled 1=enabled	Power Management
	6	SLEEP	0	Sleep Mode enable 0 = normal device operation 1 = residual current reduced in device standby mode	Power Management
	5	BOOSTENR	0	Right channel Input BOOST enable 0 = Boost stage OFF 1 = Boost stage ON	Power Management
	4	BOOSTENL	0	Left channel Input BOOST enable 0 = Boost stage OFF 1 = Boost stage ON	Power Management

REGISTER ADDRESS	BIT	LABEL	DEFAULT	DESCRIPTION	REFER TO
	3	INPPGAENR	0	Right channel input PGA enable 0 = disabled 1 = enabled	Power Management
	2	INPPGAENL	0	Left channel input PGA enable 0 = disabled 1 = enabled	Power Management
	1	ADCENR	0	Enable ADC right channel: 0 = ADC disabled 1 = ADC enabled	Analogue to Digital Converter (ADC)
	0	ADCENL	0	Enable ADC left channel: 0 = ADC disabled 1 = ADC enabled	Analogue to Digital Converter (ADC)
R3 (03h)	8	OUT4EN	0	OUT4 enable 0 = disabled 1 = enabled	Power Management
	7	OUT3EN	0	OUT3 enable 0 = disabled 1 = enabled	Power Management
	6	LOUT2EN	0	LOUT2 enable 0 = disabled 1 = enabled	Power Management
	5	ROUT2EN	0	ROUT2 enable 0 = disabled 1 = enabled	Power Management
	4		0	Reserved	Analogue Outputs
	3	RMIXEN	0	Right output channel mixer enable: 0 = disabled 1 = enabled	Analogue Outputs
	2	LMIXEN	0	Left output channel mixer enable: 0 = disabled 1 = enabled	Analogue Outputs
	1	DACENR	0	Right channel DAC enable 0 = DAC disabled 1 = DAC enabled	Analogue Outputs
	0	DACENL	0	Left channel DAC enable 0 = DAC disabled 1 = DAC enabled	Analogue Outputs
4 (04h)	8	BCP	0	BCLK polarity 0=normal 1=inverted	Digital Audio Interfaces
	7	LRP	0	LRC clock polarity 0=normal 1=inverted	Digital Audio Interfaces
	6:5	WL	10	Word length 00=16 bits 01=20 bits 10=24 bits 11=32 bits	Digital Audio Interfaces

REGISTER ADDRESS	BIT	LABEL	DEFAULT	DESCRIPTION	REFER TO
	4:3	FMT	10	Audio interface Data Format Select: 00=Right Justified 01=Left Justified 10=I ² S format 11= DSP/PCM mode	Digital Audio Interfaces
	2	DLRSWAP	0	Controls whether DAC data appears in 'right' or 'left' phases of LRC clock: 0=DAC data appears in 'left' phase of LRC 1=DAC data appears in 'right' phase of LRC	Digital Audio Interfaces
	1	ALRSWAP	0	Controls whether ADC data appears in 'right' or 'left' phases of LRC clock: 0=ADC data appears in 'left' phase of LRC 1=ADC data appears in 'right' phase of LRC	Digital Audio Interfaces
	0	MONO	0	Selects between stereo and mono device operation: 0=Stereo device operation 1=Mono device operation. Data appears in 'left' phase of LRC	Digital Audio Interfaces
5 (05h)	8:6		000	Reserved	
	5	WL8	0	Companding Control 8-bit mode 0=off 1=device operates in 8-bit mode	Digital Audio Interfaces
	4:3	DAC_COMP	00	DAC companding 00=off 01=reserved 10= μ -law 11=A-law	Digital Audio Interfaces
	2:1	ADC_COMP	00	ADC companding 00=off 01=reserved 10= μ -law 11=A-law	Digital Audio Interfaces
	0	LOOPBACK	0	Digital loopback function 0=No loopback 1=Loopback enabled, ADC data output is fed directly into DAC data input.	Digital Audio Interfaces
6 (06h)	8	CLKSEL	1	Controls the source of the clock for all internal operation: 0=MCLK 1=PLL output	Digital Audio Interfaces
	7:5	MCLKDIV	010	Sets the scaling for either the MCLK or PLL clock output (under control of CLKSEL) 000=divide by 1 001=divide by 1.5 010=divide by 2 011=divide by 3 100=divide by 4 101=divide by 6 110=divide by 8 111=divide by 12	Digital Audio Interfaces

REGISTER ADDRESS	BIT	LABEL	DEFAULT	DESCRIPTION	REFER TO
	4:2	BCLKDIV	000	Configures the BCLK output frequency, for use when the chip is in Master mode. 000=divide by 1 (BCLK= SYSCLK) 001=divide by 2 (BCLK= SYSCLK/2) 010=divide by 4 011=divide by 8 100=divide by 16 101=divide by 32 110=reserved 111=reserved	Digital Audio Interfaces
	1		0	Reserved	
	0	MS	0	Sets the chip to be master over LRC and BCLK 0=BCLK and LRC clock are inputs 1=BCLK and LRC clock are outputs generated by the WM8983 (Master Mode)	Digital Audio Interfaces
7 (07h)	3:1	SR	000	Approximate sample rate (configures the coefficients for the internal digital filters): 000=48kHz 001=32kHz 010=24kHz 011=16kHz 100=12kHz 101=8kHz 110-111=reserved	Audio Sample Rates
	0	SLOWCLKEN	0	Slow clock enable. Used for both the jack insert detect debounce circuit and the zero cross timeout. 0 = slow clock disabled 1 = slow clock enabled	Analogue Outputs
8 (08h)	5:4	OPCLKDIV	00	PLL Output clock division ratio 00=divide by 1 01=divide by 2 10=divide by 3 11=divide by 4	General Purpose Input/Output (GPIO)
	3	GPIO1POL	0	GPIO1 Polarity invert 0=Non inverted 1=Inverted	General Purpose Input/Output (GPIO)
	2:0	GPIO1SEL [2:0]	000	CSB/GPIO1 pin function select: 000= input (CSB/jack detection: depending on MODE setting) 001= reserved 010=Temp ok 011=Amute active 100=PLL clk output 101=PLL lock 110=logic 0 111=logic 1	General Purpose Input/Output (GPIO)

REGISTER ADDRESS	BIT	LABEL	DEFAULT	DESCRIPTION	REFER TO
9 (09h)	8:7		00	Reserved	
	6	JD_EN	0	Jack Detection Enable 0=disabled 1=enabled	Output Switching (Jack Detect)
	5:4	JD_SEL	00	Pin selected as jack detection input 00 = GPIO1 01 = GPIO2 10 = GPIO3 11 = Reserved	Output Switching (Jack Detect)
	3:0		0	Reserved	Output Switching (Jack Detect)
10 (0Ah)	8:7		00	Reserved	
	6	SOFTMUTE	0	Softmute enable: 0=Disabled 1=Enabled	Output Signal Path
	5:4		00	Reserved	
	3	DACOSR128	0	DAC oversample rate select 0 = 64x (lowest power) 1 = 128x (best performance)	Power Management
	2	AMUTE	0	Automute enable 0 = Amute disabled 1 = Amute enabled	Output Signal Path
	1	DACRPOL	0	Right DAC output polarity: 0 = non-inverted 1 = inverted (180 degrees phase shift)	Output Signal Path
	0	DACLPOL	0	Left DAC output polarity: 0 = non-inverted 1 = inverted (180 degrees phase shift)	Output Signal Path
11 (0Bh)	8	DACVU	N/A	DAC left and DAC right volume do not update until a 1 is written to DACVU (in reg 11 or 12)	Digital to Analogue Converter (DAC)
	7:0	DACLVOL	11111111	Left DAC Digital Volume Control 0000 0000 = Digital Mute 0000 0001 = -127dB 0000 0010 = -126.5dB ... 0.5dB steps up to 1111 1111 = 0dB	Digital to Analogue Converter (DAC)
12 (0Ch)	8	DACVU	N/A	DAC left and DAC right volume do not update until a 1 is written to DACVU (in reg 11 or 12)	Output Signal Path
	7:0	DACRVOL	11111111	Right DAC Digital Volume Control 0000 0000 = Digital Mute 0000 0001 = -127dB 0000 0010 = -126.5dB ... 0.5dB steps up to 1111 1111 = 0dB	Output Signal Path

REGISTER ADDRESS	BIT	LABEL	DEFAULT	DESCRIPTION	REFER TO
13 (0Dh)	8		0	Reserved	
	7:4	JD_EN1	0000	Output enabled when selected jack detection input is logic 1 [4]= OUT1_EN_1 [5]= OUT2_EN_1 [6]= OUT3_EN_1 [7]= OUT4_EN_1	Output Switching (Jack Detect)
	3:0	JD_EN0	0000	Output enabled when selected jack detection input is logic 0. [0]= OUT1_EN_0 [1]= OUT2_EN_0 [2]= OUT3_EN_0 [3]= OUT4_EN_0	Output Switching (Jack Detect)
14 (0Eh)	8	HPFEN	1	High Pass Filter Enable 0=disabled 1=enabled	Analogue to Digital Converter (ADC)
	7	HPFAPP	0	Select audio mode or application mode 0=Audio mode (1 st order, fc = ~3.7Hz) 1=Application mode (2 nd order, fc = HPFCUT)	Analogue to Digital Converter (ADC)
	6:4	HPFCUT	000	Application mode cut-off frequency See Table 16 for details	Analogue to Digital Converter (ADC)
	3	ADCOsr128	0	ADC oversample rate select 0 = 64x (lowest power) 1 = 128x (best performance)	Power Management
	2		0	Reserved	
	1	ADCRPOL	0	ADC right channel polarity adjust: 0=normal 1=inverted	Analogue to Digital Converter (ADC)
	0	ADCLPOL	0	ADC left channel polarity adjust: 0=normal 1=inverted	Analogue to Digital Converter (ADC)
15 (0Fh)	8	ADCVU	N/A	ADC left and ADC right volume do not update until a 1 is written to ADCVU (in reg 16 or 17)	Analogue to Digital Converter (ADC)
	7:0	ADCLVOL	11111111	Left ADC Digital Volume Control 0000 0000 = Digital Mute 0000 0001 = -127dB 0000 0010 = -126.5dB ... 0.5dB steps up to 1111 1111 = 0dB	Analogue to Digital Converter (ADC)
16 (10h)	8	ADCVU	N/A	ADC left and ADC right volume do not update until a 1 is written to ADCVU (in reg 16 or 17)	Analogue to Digital Converter (ADC)
	7:0	ADCRVOL	11111111	Right ADC Digital Volume Control 0000 0000 = Digital Mute 0000 0001 = -127dB 0000 0010 = -126.5dB ... 0.5dB steps up to 1111 1111 = 0dB	Analogue to Digital Converter (ADC)

REGISTER ADDRESS	BIT	LABEL	DEFAULT	DESCRIPTION	REFER TO
18 (12h)	8	EQ3DMODE	1	0 = Equaliser and 3D Enhancement applied to ADC path 1 = Equaliser and 3D Enhancement applied to DAC path	Output Signal Path
	7		0	Reserved	
	6:5	EQ1C	01	EQ Band 1 Cut-off Frequency: 00=80Hz 01=105Hz 10=135Hz 11=175Hz	Output Signal Path
	4:0	EQ1G	01100	EQ Band 1 Gain Control. See Table 38 for details.	Output Signal Path
19 (13h)	8	EQ2BW	0	EQ Band 2 Bandwidth Control 0=narrow bandwidth 1=wide bandwidth	Output Signal Path
	7		0	Reserved	Output Signal Path
	6:5	EQ2C	01	EQ Band 2 Centre Frequency: 00=230Hz 01=300Hz 10=385Hz 11=500Hz	Output Signal Path
	4:0	EQ2G	01100	EQ Band 2 Gain Control. See Table 38 for details.	Output Signal Path
20 (14h)	8	EQ3BW	0	EQ Band 3 Bandwidth Control 0=narrow bandwidth 1=wide bandwidth	Output Signal Path
	7		0	Reserved	Output Signal Path
	6:5	EQ3C	01	EQ Band 3 Centre Frequency: 00=650Hz 01=850Hz 10=1.1kHz 11=1.4kHz	Output Signal Path
	4:0	EQ3G	01100	EQ Band 3 Gain Control. See Table 38 for details.	Output Signal Path
21 (15h)	8	EQ4BW	0	EQ Band 4 Bandwidth Control 0=narrow bandwidth 1=wide bandwidth	Output Signal Path
	7		0	Reserved	Output Signal Path
	6:5	EQ4C	01	EQ Band 4 Centre Frequency: 00=1.8kHz 01=2.4kHz 10=3.2kHz 11=4.1kHz	Output Signal Path
	4:0	EQ4G	01100	EQ Band 4 Gain Control. See Table 38 for details.	Output Signal Path
22 (16h)	8:7		0	Reserved	Output Signal Path
	6:5	EQ5C	01	EQ Band 5 Cut-off Frequency: 00=5.3kHz 01=6.9kHz 10=9kHz 11=11.7kHz	Output Signal Path
	4:0	EQ5G	01100	EQ Band 5 Gain Control. See Table 38 for details.	Output Signal Path

REGISTER ADDRESS	BIT	LABEL	DEFAULT	DESCRIPTION	REFER TO
24 (18h)	8	LIMEN	0	Enable the DAC digital limiter: 0=disabled 1=enabled	Output Signal Path
	7:4	LIMDCY	0011	DAC Limiter Decay time (per 6dB gain change) for 44.1kHz sampling. Note that these will scale with sample rate: 0000=750us 0001=1.5ms 0010=3ms 0011=6ms 0100=12ms 0101=24ms 0110=48ms 0111=96ms 1000=192ms 1001=384ms 1010=768ms	Output Signal Path
	3:0	LIMATK	0010	DAC Limiter Attack time (per 6dB gain change) for 44.1kHz sampling. Note that these will scale with sample rate. 0000=94us 0001=188s 0010=375us 0011=750us 0100=1.5ms 0101=3ms 0110=6ms 0111=12ms 1000=24ms 1001=48ms 1010=96ms 1011 to 1111=192ms	Output Signal Path
25 (19h)	8:7		00	Reserved	
	6:4	LIMLVL	000	Programmable signal threshold level (determines level at which the DAC limiter starts to operate) 000=-1dB 001=-2dB 010=-3dB 011=-4dB 100=-5dB 101 to 111=-6dB	Output Signal Path
	3:0	LIMBOOST	0000	DAC Limiter volume boost (can be used as a stand alone volume boost when LIMEN=0): 0000 = 0dB 0001 = +1dB 0010 = +2dB 0011 = +3dB 0100 = +4dB 0101 = +5dB 0110 = +6dB 0111 = +7dB 1000 = +8dB 1001 = +9dB 1010 = +10dB 1011 = +11dB 1100 = +12dB 1101 to 1111 = reserved	Output Signal Path
27 (1Bh)	8	NFU	0	Notch filter update. The notch filter values used internally only update when one of the NFU bits is set high.	Analogue to Digital Converter (ADC)

REGISTER ADDRESS	BIT	LABEL	DEFAULT	DESCRIPTION	REFER TO
	7	NFEN	0	Notch filter enable: 0=Disabled 1=Enabled	Analogue to Digital Converter (ADC)
	6:0	NFA0[13:7]	0000000	Notch Filter a_0 coefficient, bits [13:7]	Analogue to Digital Converter (ADC)
28 (1Ch)	8	NFU	0	Notch filter update. The notch filter values used internally only update when one of the NFU bits is set high.	Analogue to Digital Converter (ADC)
	7		0	Reserved	
	6:0	NFA0[6:0]	0000000	Notch Filter a_0 coefficient, bits [6:0]	Analogue to Digital Converter (ADC)
29 (1Dh)	8	NFU	0	Notch filter update. The notch filter values used internally only update when one of the NFU bits is set high.	Analogue to Digital Converter (ADC)
	7		0	Reserved	
	6:0	NFA1[13:7]	0000000	Notch Filter a_1 coefficient, bits [13:7]	Analogue to Digital Converter (ADC)
30 (1Eh)	8	NFU	0	Notch filter update. The notch filter values used internally only update when one of the NFU bits is set high.	Analogue to Digital Converter (ADC)
	7		0	Reserved	
	6:0	NFA1[6:0]	0000000	Notch Filter a_1 coefficient, bits [6:0]	Analogue to Digital Converter (ADC)
32 (20h)	8:7	ALCSEL	00	ALC function select: 00 = ALC disabled 01 = Right channel ALC enabled 10 = Left channel ALC enabled 11 = Both channels ALC enabled	Input Limiter/ Automatic Level Control (ALC)
	6		0	Reserved	
	5:3	ALCMAX	111	Set Maximum Gain of PGA 111=+35.25dB 110=+29.25dB 101=+23.25dB 100=+17.25dB 011=+11.25dB 010=+5.25dB 001=-0.75dB 000=-6.75dB	Input Limiter/ Automatic Level Control (ALC)

REGISTER ADDRESS	BIT	LABEL	DEFAULT	DESCRIPTION	REFER TO																			
	2:0	ALCMIN	000	Set minimum gain of PGA 000=-12dB 001=-6dB 010=0dB 011=+6dB 100=+12dB 101=+18dB 110=+24dB 111=+30dB	Input Limiter/ Automatic Level Control (ALC)																			
33 (21h)	7:4	ALCHLD	0000	ALC hold time before gain is increased. 0000 = 0ms 0001 = 2.67ms 0010 = 5.33ms 0011 = 10.66ms 0100 = 21.32ms 0101 = 42.64ms 0110 = 85.28ms 0111 = 0.17s 1000 = 0.34s 1001 = 0.68s 1010 = 1.36s 1011 = 2.7s 1100 = 5.4s 1101 = 10.9s 1110 = 21.8 s 1111 = 43.7s	Input Limiter/ Automatic Level Control (ALC)																			
	3:0	ALCLVL	1011	ALC target – sets signal level at ADC input 1111 = -1.5dBFS 1110 = -1.5dBFS 1101 = -3dBFS 1100 = -4.5dBFS 1011 = -6dBFS 1010 = -7.5dBFS 1001 = -9dBFS 1000 = -10.5dBFS 0111 = -12dBFS 0110 = -13.5dBFS 0101 = -15dBFS 0100 = -16.5dBFS 0011 = -18dBFS 0010 = -19.5dBFS 0001 = -21dBFS 0000 = -22.5dBFS	Input Limiter/ Automatic Level Control (ALC)																			
34 (22h)	8	ALCMODE	0	Determines the ALC mode of operation: 0=ALC mode (Normal Operation) 1=Limiter mode	Input Limiter/ Automatic Level Control (ALC)																			
	7:4	ALCDCY [3:0]	0011	Decay (gain ramp-up) time (ALCMODE ==0) <table border="1" style="width:100%; border-collapse: collapse;"> <thead> <tr> <th></th> <th>Per step</th> <th>Per 6dB</th> <th>90% of range</th> </tr> </thead> <tbody> <tr> <td>0000</td> <td>410us</td> <td>3.3ms</td> <td>24ms</td> </tr> <tr> <td>0001</td> <td>820us</td> <td>6.6ms</td> <td>48ms</td> </tr> <tr> <td>0010</td> <td>1.64ms</td> <td>13.1ms</td> <td>192ms</td> </tr> <tr> <td colspan="4">... (time doubles with every step)</td> </tr> </tbody> </table>		Per step	Per 6dB	90% of range	0000	410us	3.3ms	24ms	0001	820us	6.6ms	48ms	0010	1.64ms	13.1ms	192ms	... (time doubles with every step)			
	Per step	Per 6dB	90% of range																					
0000	410us	3.3ms	24ms																					
0001	820us	6.6ms	48ms																					
0010	1.64ms	13.1ms	192ms																					
... (time doubles with every step)																								

REGISTER ADDRESS	BIT	LABEL	DEFAULT	DESCRIPTION				REFER TO
			0011	1010 or higher	420ms	3.36s	24.576s	Input Limiter/ Automatic Level Control (ALC)
				Decay (gain ramp-up) time (ALCMODE == 1)				
					Per step	Per 6dB	90% of range	
				0000	90.8us	726.4us	5.26ms	
				0001	181.6us	1.453ms	10.53ms	
				0010	363.2us	2.905ms	21.06ms	
				... (time doubles with every step)				
				1010	93ms	744ms	5.39s	
	3:0	ALCATK	0010	ALC attack (gain ramp-down) time (ALCMODE == 0)				
					Per step	Per 6dB	90% of range	
				0000	104us	832us	6ms	
				0001	208us	1.664ms	12ms	
				0010	416us	3.328ms	24.1ms	
				... (time doubles with every step)				
1010 or higher				106ms	852ms	6.18s		
0010					0010	ALC attack (gain ramp-down) time (ALCMODE == 1)		
		Per step	Per 6dB			90% of range		
	0000	22.7us	182.4us			1.31ms		
	0001	45.4us	363.2us			2.62ms		
	0010	90.8us	726.4us			5.26ms		
	... (time doubles with every step)							
	1010	23.2ms	186ms			1.348s		
	35 (23h)	8:4				00000	Reserved	
3		NGEN	0	ALC Noise gate function enable 1 = enable 0 = disable				Input Limiter/ Automatic Level Control (ALC)
2:0		NGTH	000	ALC Noise gate threshold: 000 = -39dB 001 = -45dB 010 = -51dB 011 = -57dB 100 = -63dB 101 = -70dB 110 = -76dB 111 = -81dB				Input Limiter/ Automatic Level Control (ALC)
36 (24h)	8:5		0000	Reserved				
	4	PLL PRESCALE	0	0 = MCLK input not divided (default) 1 = Divide MCLK by 2 before input to PLL				Master Clock and Phase Locked Loop (PLL)
	3:0	PLLN[3:0]	1000	Integer (N) part of PLL input/output frequency ratio. Use values greater than 5 and less than 13.				Master Clock and Phase Locked Loop (PLL)
37 (25h)	8:6		000	Reserved				

REGISTER ADDRESS	BIT	LABEL	DEFAULT	DESCRIPTION	REFER TO
	5:0	PLLK[23:18]	01100	Fractional (K) part of PLL1 input/output frequency ratio (treat as one 24-digit binary number).	Master Clock and Phase Locked Loop (PLL)
38 (26h)	8:0	PLLK[17:9]	010010011	Fractional (K) part of PLL1 input/output frequency ratio (treat as one 24-digit binary number).	Master Clock and Phase Locked Loop (PLL)
39 (27h)	8:0	PLLK[8:0]	011101001	Fractional (K) part of PLL1 input/output frequency ratio (treat as one 24-digit binary number).	Master Clock and Phase Locked Loop (PLL)
41 (29h)	8:4		00000	Reserved	
	3:0	DEPTH3D	0000	Stereo depth 0000 = Disabled 0001 = 6.67% 0010 = 13.3% 0011 = 20% 0100 = 26.7% 0101 = 33.3% 0110 = 40% 0111 = 46.6% 1000 = 53.3% 1001 = 60% 1010 = 66.7% 1011 = 73.3% 1100 = 80% 1101 = 86.7% 1110 = 93.3% 1111 = 100% (maximum 3D effect)	3D Stereo Enhancement
42 (2Ah)	8:6	OUT4_2ADCVOL	000	Controls the OUT4 to ADC input boost stage: 000 = Path disabled (disconnected) 001 = -12dB gain 010 = -9dB gain 011 = -6dB gain 100 = -3dB gain 101 = +0dB gain 110 = +3dB gain 111 = +6dB gain	Analogue Outputs
	5	OUT4_2LNR	0	OUT4 to L or R ADC input 0 = Right ADC input 1 = Left ADC input	Analogue Outputs
	4:3		000	Reserved	
	2	POBCTRL	0	Power-On Bias Control (Use during power Up. Reset when VMID bias is stable) 0 = Bias derived from VMID 1 = Bias derived from AVDD	
	1	DELEN	0	2 nd enable bit for L/ROUT1	
	0	OUT1DEL	0	2 stage enable for L/ROUT1	
43 (2Bh)	8	BYPL2RMIX	0	Left bypass path (from the Left channel input PGA stage) to right output mixer 0 = not selected 1 = selected	Analogue Outputs

REGISTER ADDRESS	BIT	LABEL	DEFAULT	DESCRIPTION	REFER TO
	7	BYPR2LMIX	0	Right bypass path (from the right channel input PGA stage) to Left output mixer 0 = not selected 1 = selected	Analogue Outputs
	6:5		00	Reserved	
	4	INVROUT2	0	Invert ROUT2 output 0 = Not inverted 1 = Inverted	Analogue Outputs
	3:0		0000	Reserved	
44 (2Ch)	8	MBVSEL	0	Microphone Bias Voltage Control 0 = 0.9 * AVDD1 1 = 0.65 * AVDD1	Input Signal Path
	7		0	Reserved	
	6	R2_2INPPGA	0	Connect R2 pin to right channel input PGA positive terminal. 0=R2 not connected to input PGA 1=R2 connected to input PGA amplifier positive terminal (constant input impedance).	Input Signal Path
	5	RIN2INPPGA	1	Connect RIN pin to right channel input PGA negative terminal. 0=RIN not connected to input PGA 1=RIN connected to right channel input PGA amplifier negative terminal.	Input Signal Path
	4	RIP2INPPGA	1	Connect RIP pin to right channel input PGA amplifier positive terminal. 0 = RIP not connected to input PGA 1 = right channel input PGA amplifier positive terminal connected to RIP (constant input impedance)	Input Signal Path
	3		0	Reserved	
	2	L2_2INPPGA	0	Connect L2 pin to left channel input PGA positive terminal. 0=L2 not connected to input PGA 1=L2 connected to input PGA amplifier positive terminal (constant input impedance).	Input Signal Path
	1	LIN2INPPGA	1	Connect LIN pin to left channel input PGA negative terminal. 0=LIN not connected to input PGA 1=LIN connected to input PGA amplifier negative terminal.	Input Signal Path
45 (2Dh)	8	INPPGAVU	N/A	INPPGA left and INPPGA right volume do not update until a 1 is written to INPPGAVU (in reg 45 or 46)	Input Signal Path
	7	INPPGAZCL	0	Left channel input PGA zero cross enable: 0=Update gain when gain register changes 1=Update gain on 1 st zero cross after gain register write.	Input Signal Path
	6	INPPGAMUTEL	0	Mute control for left channel input PGA: 0=Input PGA not muted, normal operation 1=Input PGA muted (and disconnected from the following input BOOST stage).	Input Signal Path

REGISTER ADDRESS	BIT	LABEL	DEFAULT	DESCRIPTION	REFER TO
	5:0	INPPGAVOLL	010000	Left channel input PGA volume 000000 = -12dB 000001 = -11.25dB . 010000 = 0dB . 111111 = 35.25dB	Input Signal Path
46 (2Eh)	8	INPPGAVU	N/A	INPPGA left and INPPGA right volume do not update until a 1 is written to INPPGAUPDATE (in reg 45 or 46)	Input Signal Path
	7	INPPGAZCR	0	Right channel input PGA zero cross enable: 0=Update gain when gain register changes 1=Update gain on 1 st zero cross after gain register write.	Input Signal Path
	6	INPPGAMUTER	0	Mute control for right channel input PGA: 0=Input PGA not muted, normal operation 1=Input PGA muted (and disconnected from the following input BOOST stage).	Input Signal Path
	5:0	INPPGAVOLR	010000	Right channel input PGA volume 000000 = -12dB 000001 = -11.25db . 010000 = 0dB . 111111 = +35.25dB	Input Signal Path
47 (2Fh)	8	PGABOOSTL	1	Boost enable for left channel input PGA: 0 = PGA output has +0dB gain through input BOOST stage. 1 = PGA output has +20dB gain through input BOOST stage.	Input Signal Path
	7		0	Reserved	
	6:4	L2_2BOOSTVOL	000	Controls the L2 pin to the left channel input boost stage: 000=Path disabled (disconnected) 001 = -12dB gain 010 = -9dB gain 011 = -6dB gain 100 = -3dB gain 101 = +0dB gain 110 = +3dB gain 111 = +6dB gain	Input Signal Path
	3		0	Reserved	
	2:0	AUXL2BOOSTVOL	000	Controls the auxiliary amplifier to the left channel input boost stage: 000=Path disabled (disconnected) 001 = -12dB gain 010 = -9dB gain 011 = -6dB gain 100 = -3dB gain 101 = +0dB gain 110 = +3dB gain 111 = +6dB gain	Input Signal Path

REGISTER ADDRESS	BIT	LABEL	DEFAULT	DESCRIPTION	REFER TO
48 (30h)	8	PGABOOSTR	1	Boost enable for right channel input PGA: 0 = PGA output has +0dB gain through input BOOST stage. 1 = PGA output has +20dB gain through input BOOST stage.	Input Signal Path
	7		0	Reserved	
	6:4	R2_2BOOSTVOL	000	Controls the R2 pin to the right channel input boost stage: 000=Path disabled (disconnected) 001 = -12dB 010 = -9dB gain 011 = -6dB gain 100 = -3dB gain 101 = +0dB gain 110 = +3dB gain 111 = +6dB gain	Input Signal Path
	3		0	Reserved	
	2:0	AUXR2BOOSTVOL	000	Controls the auxiliary amplifier to the right channel input boost stage: 000=Path disabled (disconnected) 001 = -12dB gain 010 = -9dB gain 011 = -6dB gain 100 = -3dB gain 101 = +0dB gain 110 = +3dB gain 111 = +6dB gain	Input Signal Path
49 (31h)	8:7		00	Reserved	
	6	DACL2RMIX	0	Left DAC output to right output mixer 0 = not selected 1 = selected	Analogue Outputs
	5	DACR2LMIX	0	Right DAC output to left output mixer 0 = not selected 1 = selected	Analogue Outputs
	3	OUT3BOOST	0	Output 3 Gain 0 = OUT3 output gain = -1; DC = AVDD1 / 2 1 = OUT3 output gain = +1.5 DC = 1.5 x AVDD1 / 2	Analogue Outputs
	4	OUT4BOOST	0	Output 4 Gain 0 = OUT4 output gain = -1; DC = AVDD1 / 2 1 = OUT4 output gain = +1.5 DC = 1.5 x AVDD1 / 2	Analogue Outputs
	2	SPKBOOST	0	Speaker Gain 0 = speaker gain = -1; DC = AVDD1 / 2 1 = speaker gain = +1.5; DC = 1.5 x AVDD1 / 2	Analogue Outputs
	1	TSDEN	1	Thermal Shutdown Enable 0 : thermal shutdown disabled 1 : thermal shutdown enabled	Analogue Outputs

REGISTER ADDRESS	BIT	LABEL	DEFAULT	DESCRIPTION	REFER TO
	0	VROI	0	VREF (AVDD/2 or 1.5xAVDD/2) to analogue output resistance 0: approx 1kΩ 1: approx 30 kΩ	Analogue Outputs
50 (32h)	8:6	AUXLMIXVOL	000	Aux left channel input to left mixer volume control: 000 = -15dB 001 = -12dB ... 101 = 0dB 110 = +3dB 111 = +6dB	Analogue Outputs
	5	AUXL2LMIX	0	Left Auxiliary input to left channel output mixer: 0 = not selected 1 = selected	Analogue Outputs
	4:2	BYPLMIXVOL	000	Left bypass volume control to output channel mixer: 000 = -15dB 001 = -12dB 010 = -9dB 011 = -6dB 100 = -3dB 101 = 0dB 110 = +3dB 111 = +6dB	Analogue Outputs
	1	BYPL2LMIX	0	Left bypass path (from the left channel input PGA stage) to left output mixer 0 = not selected 1 = selected	Analogue Outputs
	0	DACL2LMIX	1	Left DAC output to left output mixer 0 = not selected 1 = selected	Analogue Outputs
51 (33h)	8:6	AUXRMIXVOL	000	Aux right channel input to right mixer volume control: 000 = -15dB 001 = -12dB 010 = -9dB 011 = -6dB 100 = -3dB 101 = 0dB 110 = +3dB 111 = +6dB	Analogue Outputs
	5	AUXR2RMIX	0	Right Auxiliary input to right channel output mixer: 0 = not selected 1 = selected	Analogue Outputs

REGISTER ADDRESS	BIT	LABEL	DEFAULT	DESCRIPTION	REFER TO
	4:2	BYPRMIXVOL	000	Right bypass volume control to output channel mixer: 000 = -15dB 001 = -12dB 010 = -9dB 011 = -6dB 100 = -3dB 101 = 0dB 110 = +3dB 111 = +6dB	Analogue Outputs
	1	BYPR2RMIX	0	Right bypass path (from the right channel input PGA stage) to right output mixer 0 = not selected 1 = selected	Analogue Outputs
	0	DACR2RMIX	1	Right DAC output to right output mixer 0 = not selected 1 = selected	Analogue Outputs
52 (34h)	8	OUT1VU	N/A	LOUT1 and ROUT1 volumes do not update until a 1 is written to OUT1VU (in reg 52 or 53)	Analogue Outputs
	7	LOUT1ZC	0	Headphone volume zero cross enable: 1 = Change gain on zero cross only 0 = Change gain immediately	Analogue Outputs
	6	LOUT1MUTE	0	Left headphone output mute: 0 = Normal operation 1 = Mute	Analogue Outputs
	5:0	LOUT1VOL	111001	Left headphone output volume: 000000 = -57dB 000001 = -56dB ... 111001 = 0dB ... 111111 = +6dB	Analogue Outputs
53 (35h)	8	OUT1VU	N/A	LOUT1 and ROUT1 volumes do not update until a 1 is written to OUT1VU (in reg 52 or 53)	Analogue Outputs
	7	ROUT1ZC	0	Headphone volume zero cross enable: 1 = Change gain on zero cross only 0 = Change gain immediately	Analogue Outputs
	6	ROUT1MUTE	0	Right headphone output mute: 0 = Normal operation 1 = Mute	Analogue Outputs
	5:0	ROUT1VOL	111001	Right headphone output volume: 000000 = -57dB 000001 = -56dB ... 111001 = 0dB ... 111111 = +6dB	Analogue Outputs
54 (36h)	8	OUT2VU	N/A	LOUT2 and ROUT2 volumes do not update until a 1 is written to OUT2VU (in reg 54 or 55)	Analogue Outputs
	7	LOUT2ZC	0	Left speaker volume zero cross enable: 1 = Change gain on zero cross only 0 = Change gain immediately	Analogue Outputs

REGISTER ADDRESS	BIT	LABEL	DEFAULT	DESCRIPTION	REFER TO
	6	LOUT2MUTE	0	Left speaker output mute: 0 = Normal operation 1 = Mute	Analogue Outputs
	5:0	LOUT2VOL	111001	Left speaker output volume: 000000 = -57dB 000001 = -56dB ... 111001 = 0dB ... 111111 = +6dB	Analogue Outputs
55 (37h)	8	OUT2VU	N/A	LOUT2 and ROUT2 volumes do not update until a 1 is written to OUT2VU (in reg 54 or 55)	Analogue Outputs
	7	ROUT2ZC	0	Right speaker volume zero cross enable: 1 = Change gain on zero cross only 0 = Change gain immediately	Analogue Outputs
	6	ROUT2MUTE	0	Right speaker output mute: 0 = Normal operation 1 = Mute	Analogue Outputs
	5:0	ROUT2VOL	111001	Right speaker output volume: 000000 = -57dB 000001 = -56dB ... 111001 = 0dB ... 111111 = +6dB	Analogue Outputs
56 (38h)	8:7		00	Reserved	
	6	OUT3MUTE	0	0 = Output stage outputs OUT3 mixer 1 = Output stage muted – drives out VMID. Can be used as VMID buffer in this mode.	Analogue Outputs
	5:4		00	Reserved	
	3	OUT4_2OUT3	0	OUT4 mixer output to OUT3 0 = disabled 1 = enabled	Analogue Outputs
	2	BYPL2OUT3	0	Left ADC input to OUT3 0 = disabled 1 = enabled	Analogue Outputs
	1	LMIX2OUT3	0	Left Output mixer to OUT3 0 = disabled 1 = enabled	Analogue Outputs
	0	LDAC2OUT3	1	Left DAC output to OUT3 0 = disabled 1 = enabled	Analogue Outputs
57 (39h)	8		0	Reserved	
	7	OUT3_2OUT4	0	OUT3 mixer output to OUT4 0 = disabled 1 = enabled	Analogue Outputs
	6	OUT4MUTE	0	0 = Output stage outputs OUT4 mixer 1 = Output stage muted – drives out VMID. Can be used as VMID buffer in this mode.	Analogue Outputs
	5	OUT4ATTN	0	0 = OUT4 normal output 1 = OUT4 attenuated by 6dB	Analogue Outputs

REGISTER ADDRESS	BIT	LABEL	DEFAULT	DESCRIPTION	REFER TO
	4	LMIX2OUT4	0	Left Output mixer to OUT4 0 = disabled 1 = enabled	Analogue Outputs
	3	LDAC2OUT4	0	Left DAC to OUT4 0 = disabled 1 = enabled	Analogue Outputs
	2	BYPR2OUT4	0	Right ADC input to OUT4 0 = disabled 1 = enabled	Analogue Outputs
	1	RMIX2OUT4	0	Right Output mixer to OUT4 0 = disabled 1 = enabled	Analogue Outputs
	0	RDAC2OUT4	1	Right DAC output to OUT4 0 = disabled 1 = enabled	Analogue Outputs
59 (3Bh)	8:2		0000000	Reserved	
	1:0	ALCTST	00	ALC Test Mode 00 = disabled 11 = enabled	ALC Test Mode
61 (3Dh)	8	BIASCUT	0	Global bias control 0 = normal 1 = 0.5x	Bias Control
	7:0		00000000	Reserved	

DIGITAL FILTER CHARACTERISTICS

PARAMETER	TEST CONDITIONS	MIN	TYP	MAX	UNIT
ADC Filter					
Passband	+/- 0.025dB	0		0.454fs	
	-6dB		0.5fs		
Passband Ripple				+/- 0.025	dB
Stopband		0.546fs			
Stopband Attenuation	f > 0.546fs	-60			dB
Group Delay			21/fs		
ADC High Pass Filter					
High Pass Filter Corner Frequency	-3dB		3.7		Hz
	-0.5dB		10.4		
	-0.1dB		21.6		
DAC Filter					
Passband	+/- 0.035dB	0		0.454fs	
	-6dB		0.5fs		
Passband Ripple				+/-0.035	dB
Stopband		0.546fs			
Stopband Attenuation	f > 0.546fs	-55			dB
Group Delay			29/fs		

Table 71 Digital Filter Characteristics
TERMINOLOGY

1. Stop Band Attenuation (dB) – the degree to which the frequency spectrum is attenuated (outside audio band)
2. Pass-band Ripple – any variation of the frequency response in the pass-band region

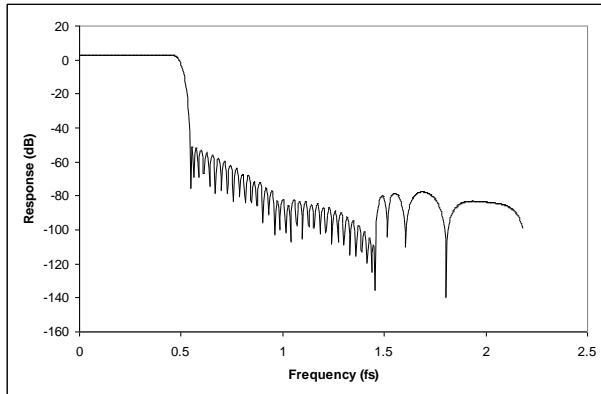
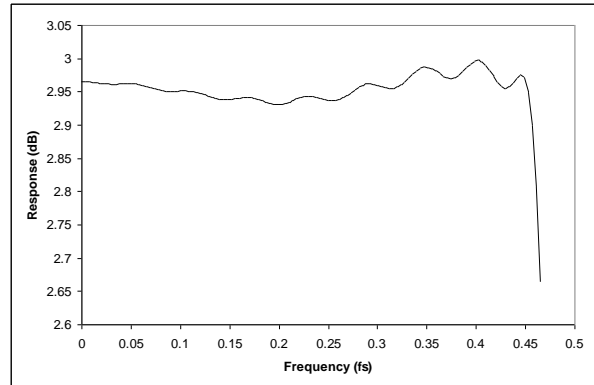
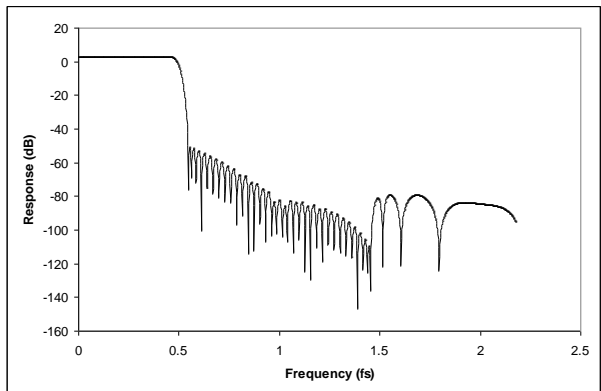
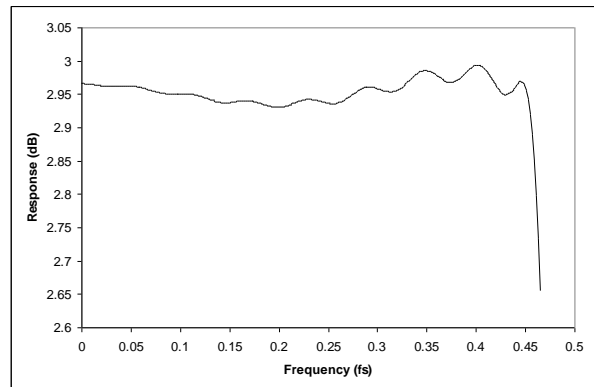
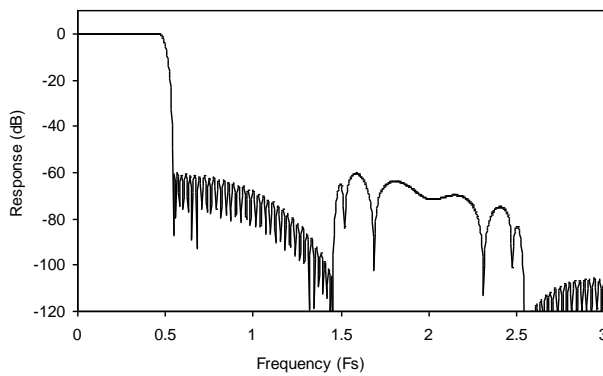
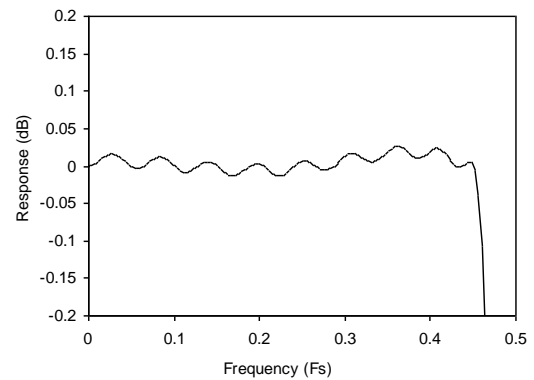
DAC FILTER RESPONSES

Figure 54 DAC Digital Filter Frequency Response (128xOSR)

Figure 55 DAC Digital Filter Ripple (128xOSR)

Figure 56 DAC Digital Filter Frequency Response (64xOSR)

Figure 57 DAC Digital Filter Ripple (64xOSR)
ADC FILTER RESPONSES

Figure 58 ADC Digital Filter Frequency Response

Figure 59 ADC Digital Filter Ripple

HIGHPASS FILTER

The WM8983 has a selectable digital highpass filter in the ADC filter path. This filter has two modes, audio and applications. In audio mode, the filter is a 1st order IIR with a cut-off of around 3.7Hz. In applications mode, the filter is a 2nd order high pass filter with a selectable cut-off frequency.

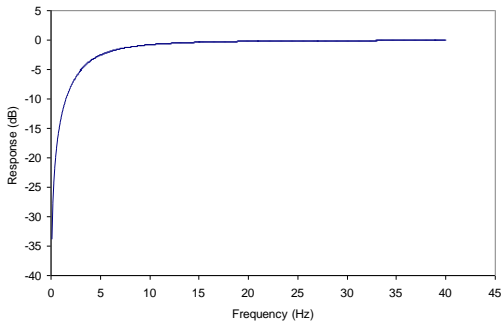

Figure 60 ADC Highpass Filter Response, HPFAPP=0

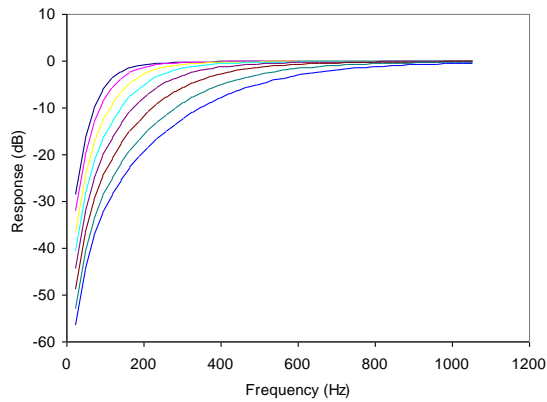

Figure 61 ADC Highpass Filter Responses (48kHz), HPFAPP=1, all cut-off settings shown.

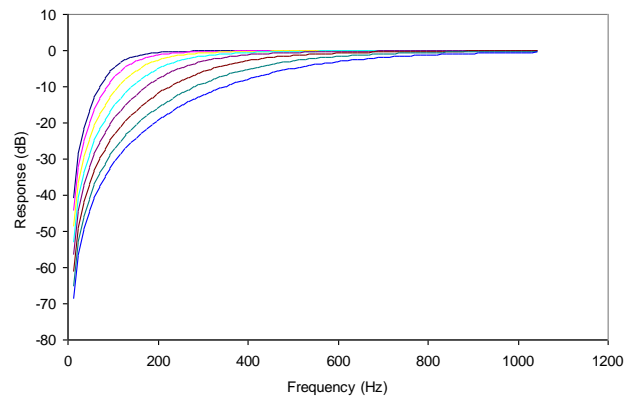

Figure 62 ADC Highpass Filter Responses (24kHz), HPFAPP=1, all cut-off settings shown.

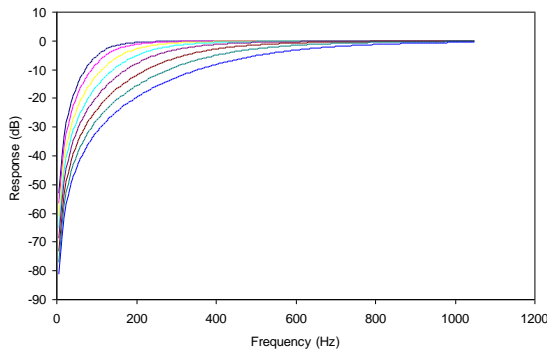
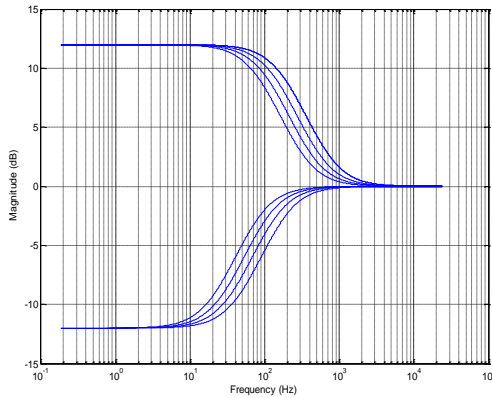
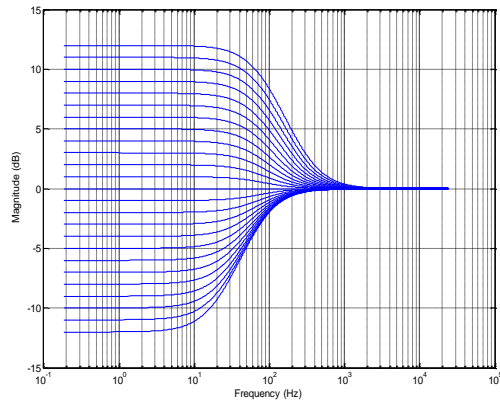
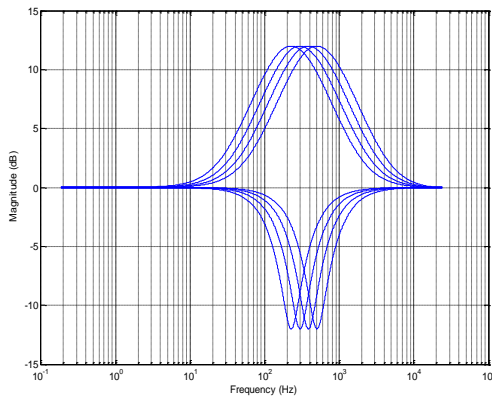
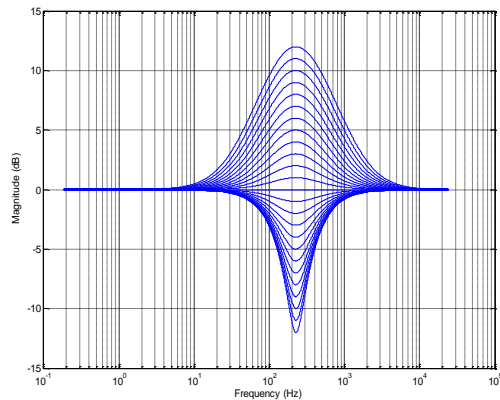
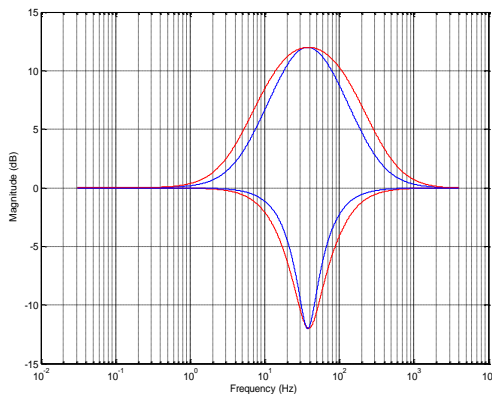

Figure 63 ADC Highpass Filter Responses (12kHz), HPFAPP=1, all cut-off settings shown.

5-BAND EQUALISER

The WM8983 has a 5-band equaliser which can be applied to either the ADC path or the DAC path. The plots from Figure 64 to Figure 77 show the frequency responses of each filter with a sampling frequency of 48kHz, firstly showing the different cut-off/centre frequencies with a gain of $\pm 12\text{dB}$, and secondly a sweep of the gain from -12dB to $+12\text{dB}$ for the lowest cut-off/centre frequency of each filter.

Figure 64 EQ Band 1 Low Frequency Shelf Filter Cut-offs

Figure 65 EQ Band 1 Gains for Lowest Cut-off Frequency

Figure 66 EQ Band 2 – Peak Filter Centre Frequencies, EQ2BW=0

Figure 67 EQ Band 2 – Peak Filter Gains for Lowest Cut-off Frequency, EQ2BW=0

Figure 68 EQ Band 2 – EQ2BW=0, EQ2BW=1

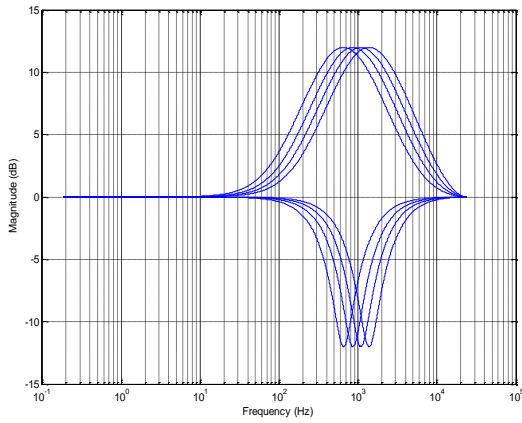

Figure 69 EQ Band 3 – Peak Filter Centre Frequencies, EQ3BW=0

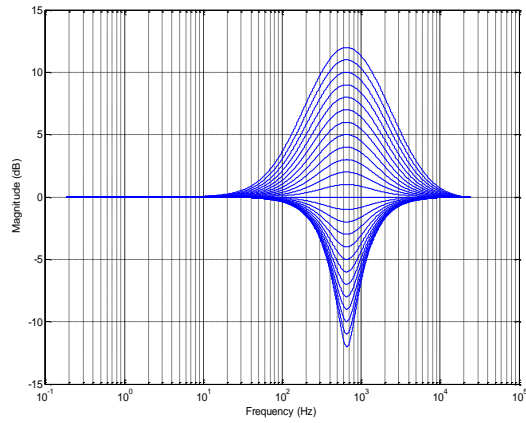

Figure 70 EQ Band 3 – Peak Filter Gains for Lowest Cut-off Frequency, EQ3BW=0

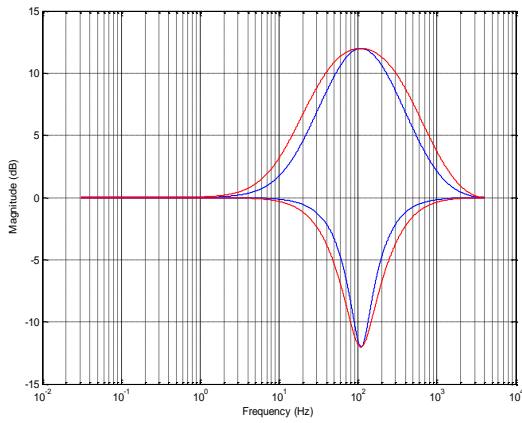

Figure 71 EQ Band 3 – EQ3BW=0, EQ3BW=1

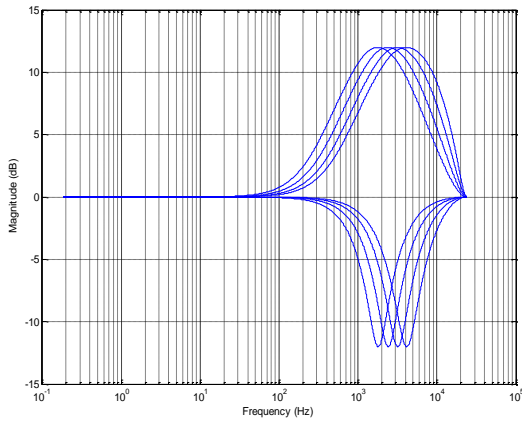

Figure 72 EQ Band 4 – Peak Filter Centre Frequencies, EQ3BW=0

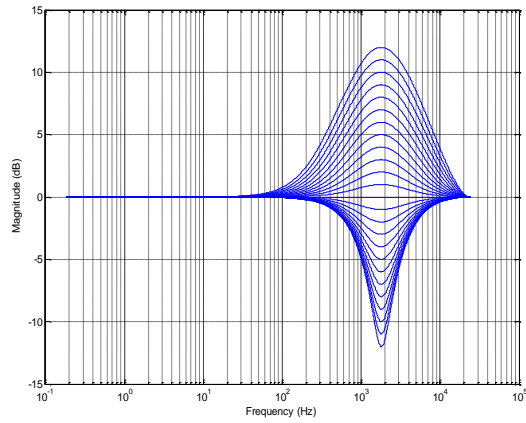

Figure 73 EQ Band 4 – Peak Filter Gains for Lowest Cut-off Frequency, EQ4BW=0

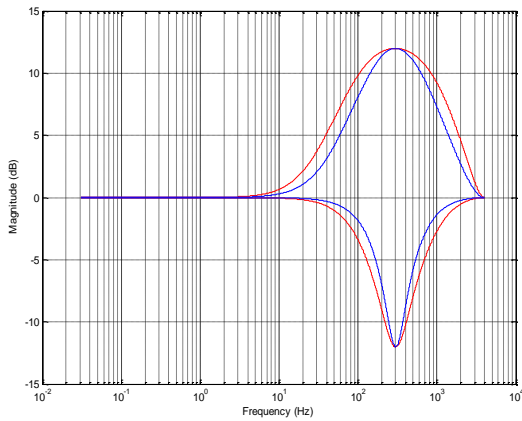

Figure 74 EQ Band 4 – EQ3BW=0, EQ3BW=1

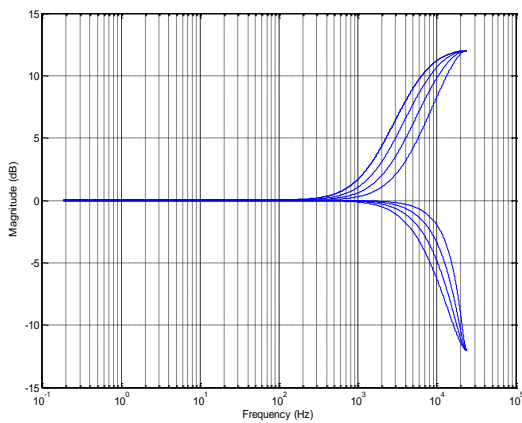

Figure 75 EQ Band 5 High Frequency Shelf Filter Cut-offs

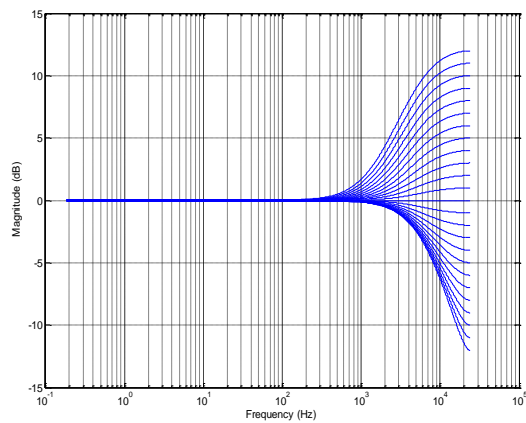

Figure 76 EQ Band 5 Gains for Lowest Cut-off Frequency

Figure 77 shows the result of having the gain set on more than one channel simultaneously. The blue traces show each band (lowest cut-off/centre frequency) with $\pm 12\text{dB}$ gain. The red traces show the cumulative effect of all bands with $+12\text{dB}$ gain and all bands -12dB gain, with EqxBW=0 for the peak filters.

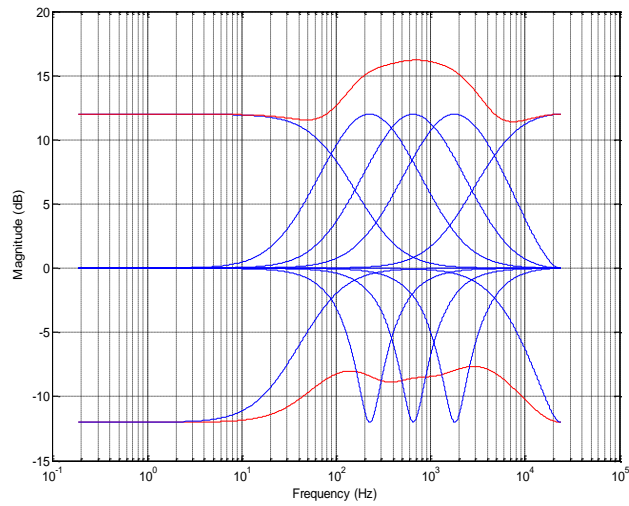
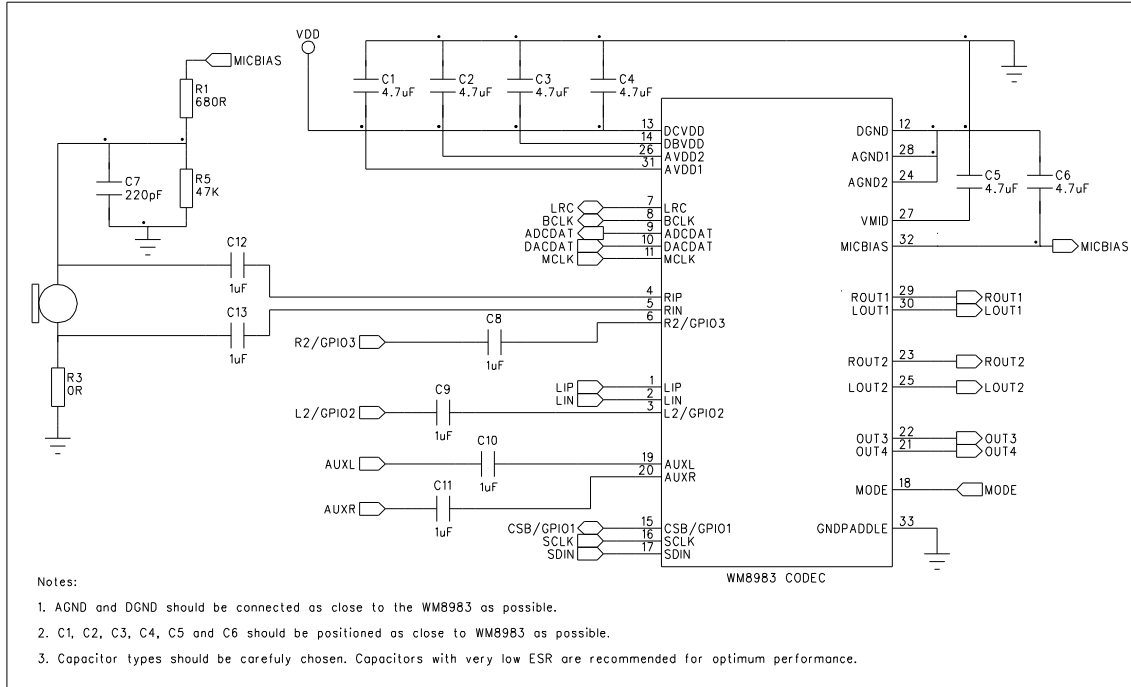
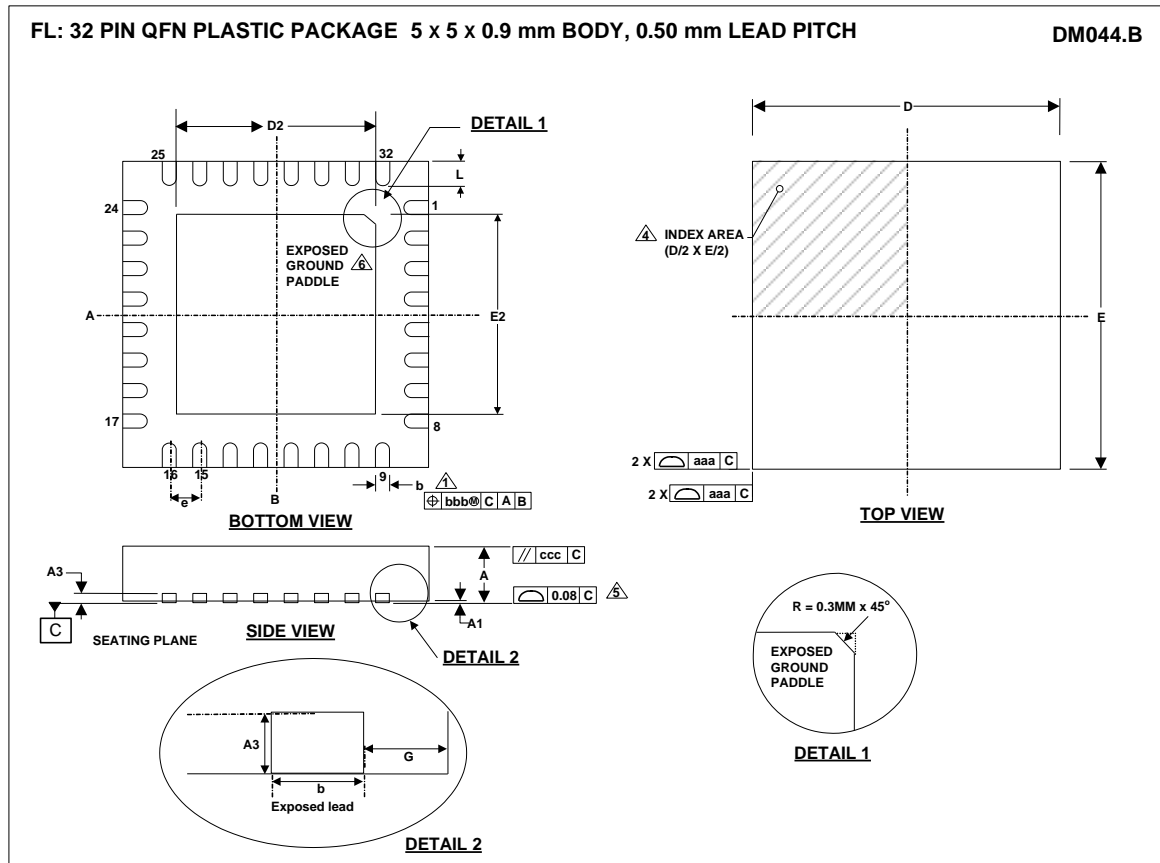

Figure 77 Cumulative Frequency Boost/Cut

APPLICATIONS INFORMATION
RECOMMENDED EXTERNAL COMPONENTS

Figure 78 External Component Diagram

PACKAGE DIAGRAM
PACKAGE DIAGRAM FOR DEVICES MARKED KF3 / LK8 / RFD

Symbols	Dimensions (mm)			NOTE
	MIN	NOM	MAX	
A	0.80	0.85	0.90	
A1	0	0.02	0.05	
A3		0.203 REF		
b	0.20	0.25	0.30	1
D		5.00 BSC		
D2	3.05	3.10	3.15	2
E		5.00 BSC		
E2	3.05	3.10	3.15	2
e		0.50 BSC		
G		0.625		
L	0.35	0.40	0.45	
Tolerances of Form and Position				
aaa		0.15		
bbb		0.10		
ccc		0.10		
REF:	JEDEC, MO-220, VARIATION VHHD-5.			

NOTES:

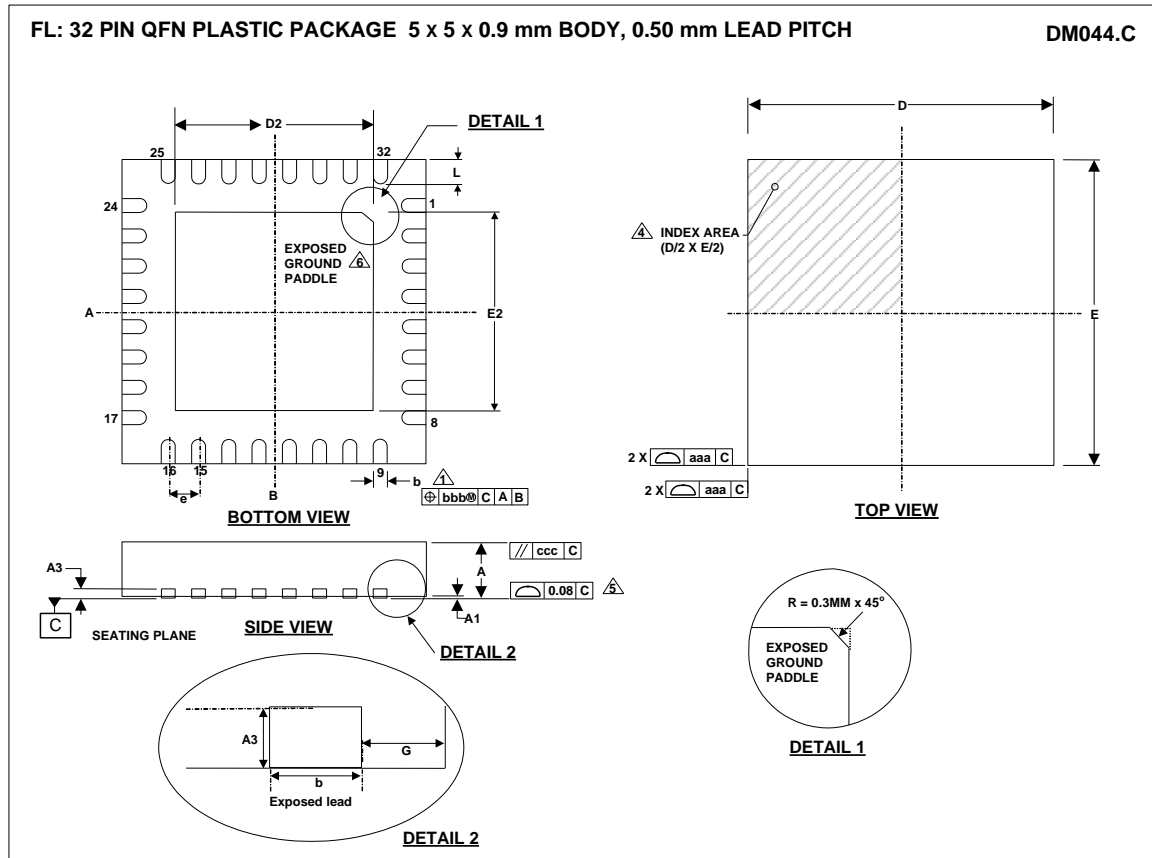
1. DIMENSION b APPLIES TO METALLIZED TERMINAL AND IS MEASURED BETWEEN 0.15 mm AND 0.30 mm FROM TERMINAL TIP.
2. FALLS WITHIN JEDEC, MO-220, VARIATION VHHD-5.
3. ALL DIMENSIONS ARE IN MILLIMETRES.
4. THE TERMINAL #1 IDENTIFIER AND TERMINAL NUMBERING CONVENTION SHALL CONFORM TO JEDEC 95-1 SPP-002.
5. COPLANARITY APPLIES TO THE EXPOSED HEAT SINK SLUG AS WELL AS THE TERMINALS.
6. REFER TO APPLICATION NOTE WAN_0118 FOR FURTHER INFORMATION REGARDING PCB FOOTPRINTS AND QFN PACKAGE SOLDERING.
7. THIS DRAWING IS SUBJECT TO CHANGE WITHOUT NOTICE.

PACKAGE DIAGRAM FOR DEVICES MARKED CT8

Symbols	Dimensions (mm)			NOTE
	MIN	NOM	MAX	
A	0.80	0.85	0.90	
A1	0	0.035	0.05	
A3		0.203 REF		
b	0.20	0.25	0.30	1
D		5.00 BSC		
D2	3.4	3.5	3.6	2
E		5.00 BSC		
E2	3.4	3.5	3.6	2
e		0.50 BSC		
G		0.625		
L	0.35	0.40	0.45	
Tolerances of Form and Position				
aaa	0.10			
bbb	0.10			
ccc	0.08			
REF:	JEDEC, MO-220, VARIATION VHHD-5.			

- NOTES:
1. DIMENSION b APPLIES TO METALLIZED TERMINAL AND IS MEASURED BETWEEN 0.15 mm AND 0.30 mm FROM TERMINAL TIP.
 2. FALLS WITHIN JEDEC, MO-220, VARIATION VHHD-5.
 3. ALL DIMENSIONS ARE IN MILLIMETRES.
 4. THE TERMINAL #1 IDENTIFIER AND TERMINAL NUMBERING CONVENTION SHALL CONFORM TO JEDEC 95-1 SPP-002.
 5. COPLANARITY APPLIES TO THE EXPOSED HEAT SINK SLUG AS WELL AS THE TERMINALS.
 6. REFER TO APPLICATION NOTE WAN_0118 FOR FURTHER INFORMATION REGARDING PCB FOOTPRINTS AND QFN PACKAGE SOLDERING.
 7. THIS DRAWING IS SUBJECT TO CHANGE WITHOUT NOTICE.

IMPORTANT NOTICE

Contacting Cirrus Logic Support

For all product questions and inquiries, contact a Cirrus Logic Sales Representative.

To find one nearest you, go to www.cirrus.com.

For the purposes of our terms and conditions of sale, "Preliminary" or "Advanced" datasheets are non-final datasheets that include but are not limited to datasheets marked as "Target", "Advance", "Product Preview", "Preliminary Technical Data" and/or "Pre-production." Products provided with any such datasheet are therefore subject to relevant terms and conditions associated with "Preliminary" or "Advanced" designations. The products and services of Cirrus Logic International (UK) Limited; Cirrus Logic, Inc.; and other companies in the Cirrus Logic group (collectively either "Cirrus Logic" or "Cirrus") are sold subject to Cirrus Logic's terms and conditions of sale supplied at the time of order acknowledgment, including those pertaining to warranty, indemnification, and limitation of liability. Software is provided pursuant to applicable license terms. Cirrus Logic reserves the right to make changes to its products and specifications or to discontinue any product or service without notice. Customers should therefore obtain the latest version of relevant information from Cirrus Logic to verify that the information is current and complete. Testing and other quality control techniques are utilized to the extent Cirrus Logic deems necessary. Specific testing of all parameters of each device is not necessarily performed. In order to minimize risks associated with customer applications, the customer must use adequate design and operating safeguards to minimize inherent or procedural hazards. Cirrus Logic is not liable for applications assistance or customer product design. The customer is solely responsible for its selection and use of Cirrus Logic products. Use of Cirrus Logic products may entail a choice between many different modes of operation, some or all of which may require action by the user, and some or all of which may be optional. Nothing in these materials should be interpreted as instructions or suggestions to choose one mode over another. Likewise, description of a single mode should not be interpreted as a suggestion that other modes should not be used or that they would not be suitable for operation. Features and operations described herein are for illustrative purposes only.

CERTAIN APPLICATIONS USING SEMICONDUCTOR PRODUCTS MAY INVOLVE POTENTIAL RISKS OF DEATH, PERSONAL INJURY, OR SEVERE PROPERTY OR ENVIRONMENTAL DAMAGE ("CRITICAL APPLICATIONS"). CIRRUS LOGIC PRODUCTS ARE NOT DESIGNED, AUTHORIZED OR WARRANTED FOR USE IN PRODUCTS SURGICALLY IMPLANTED INTO THE BODY, AUTOMOTIVE SAFETY OR SECURITY DEVICES, NUCLEAR SYSTEMS, LIFE SUPPORT PRODUCTS OR OTHER CRITICAL APPLICATIONS. INCLUSION OF CIRRUS LOGIC PRODUCTS IN SUCH APPLICATIONS IS UNDERSTOOD TO BE FULLY AT THE CUSTOMER'S RISK AND CIRRUS LOGIC DISCLAIMS AND MAKES NO WARRANTY, EXPRESS, STATUTORY OR IMPLIED, INCLUDING THE IMPLIED WARRANTIES OF MERCHANTABILITY AND FITNESS FOR PARTICULAR PURPOSE, WITH REGARD TO ANY CIRRUS LOGIC PRODUCT THAT IS USED IN SUCH A MANNER. IF THE CUSTOMER OR CUSTOMER'S CUSTOMER USES OR PERMITS THE USE OF CIRRUS LOGIC PRODUCTS IN CRITICAL APPLICATIONS, CUSTOMER AGREES, BY SUCH USE, TO FULLY INDEMNIFY CIRRUS LOGIC, ITS OFFICERS, DIRECTORS, EMPLOYEES, DISTRIBUTORS AND OTHER AGENTS FROM ANY AND ALL LIABILITY, INCLUDING ATTORNEYS' FEES AND COSTS, THAT MAY RESULT FROM OR ARISE IN CONNECTION WITH THESE USES.

This document is the property of Cirrus Logic and by furnishing this information, Cirrus Logic grants no license, express or implied, under any patents, mask work rights, copyrights, trademarks, trade secrets or other intellectual property rights. Any provision or publication of any third party's products or services does not constitute Cirrus Logic's approval, license, warranty or endorsement thereof. Cirrus Logic gives consent for copies to be made of the information contained herein only for use within your organization with respect to Cirrus Logic integrated circuits or other products of Cirrus Logic, and only if the reproduction is without alteration and is accompanied by all associated copyright, proprietary and other notices and conditions (including this notice). This consent does not extend to other copying such as copying for general distribution, advertising or promotional purposes, or for creating any work for resale. This document and its information is provided "AS IS" without warranty of any kind (express or implied). All statutory warranties and conditions are excluded to the fullest extent possible. No responsibility is assumed by Cirrus Logic for the use of information herein, including use of this information as the basis for manufacture or sale of any items, or for infringement of patents or other rights of third parties. Cirrus Logic, Cirrus, the Cirrus Logic logo design, and SoundClear are among the trademarks of Cirrus Logic. Other brand and product names may be trademarks or service marks of their respective owners.

Copyright © 2005–2016 Cirrus Logic, Inc. All rights reserved.

REVISION HISTORY

DATE	REV	DESCRIPTION OF CHANGES	CHANGED BY
08/08/13	4.4	Delete AUXR > ROUT2 signal path. Miscellaneous formatting updates.	PH
15/01/15	4.5	Selectable ROUT2 inversion (INVROUT2) added in Audio Paths Overview diagram	PH
10/08/16	4.6	New package drawing incorporated, for devices marked CT8	PH

Mouser Electronics

Authorized Distributor

Click to View Pricing, Inventory, Delivery & Lifecycle Information:

[Cirrus Logic:](#)

[WM8983GEFL/V](#) [WM8983GEFL/RV](#)



Стандарт Электрон Связь

Мы молодая и активно развивающаяся компания в области поставок электронных компонентов. Мы поставляем электронные компоненты отечественного и импортного производства напрямую от производителей и с крупнейших складов мира.

Благодаря сотрудничеству с мировыми поставщиками мы осуществляем комплексные и плановые поставки широчайшего спектра электронных компонентов.

Собственная эффективная логистика и склад в обеспечивает надежную поставку продукции в точно указанные сроки по всей России.

Мы осуществляем техническую поддержку нашим клиентам и предпродажную проверку качества продукции. На все поставляемые продукты мы предоставляем гарантию .

Осуществляем поставки продукции под контролем ВП МО РФ на предприятия военно-промышленного комплекса России , а также работаем в рамках 275 ФЗ с открытием отдельных счетов в уполномоченном банке. Система менеджмента качества компании соответствует требованиям ГОСТ ISO 9001.

Минимальные сроки поставки, гибкие цены, неограниченный ассортимент и индивидуальный подход к клиентам являются основой для выстраивания долгосрочного и эффективного сотрудничества с предприятиями радиоэлектронной промышленности, предприятиями ВПК и научно-исследовательскими институтами России.

С нами вы становитесь еще успешнее!

Наши контакты:

Телефон: +7 812 627 14 35

Электронная почта: sales@st-electron.ru

Адрес: 198099, Санкт-Петербург,
Промышленная ул, дом № 19, литера Н,
помещение 100-Н Офис 331