

MIC-7500

Compact Fanless System with 6th Gen Intel® Core™ i Processor



Features

- Intel® 6th Gen Core™ i7/i5/i3/Celeron® (BGA-type) processor with Intel® QM170 chipset
- Wide operating temperature (-20 ~ 60 °C)
- 9 ~ 36 V DC input power range
- 2 x RS-232/422/485 and 4 x RS232 serial ports (with expansion cable)
- 1 x 2.5" HDD/SSD, 1 x CFast, and 1 x mSATA
- Supports isolation COM and 32-bit GPIO modules
- 2 x GigaLAN and 8 x USB 3.0
- VGA and DVI output
- Supports Advantech i-Modules, SUSIAccess, and embedded software APIs

Specifications

System Chipset	CPU	Intel® Core™ i7-6820EQ	Intel® Core™ i7-6822EQ	Intel® Core™ i5-6442EQ	Intel® Core™ i3-6102E	Intel® Celeron® G3900E
	Core Numbers	4	4	4	2	2
	Base Frequency	2.8 GHz	2.0 GHz	1.9GHz	1.9 GHz	2.4 GHz
	Max Turbo Frequency	3.5 GHz	2.8 GHz	2.7 GHz		
	L3 Cache	8 MB	8 MB	6 MB	3 MB	2 MB
	Chipset	Intel® QM170				
Memory	BIOS	AMI® SPI 64 Mb				
	Technology	Dual-channel DDR4 2133/2400 MHz (without ECC)				
	Socket	2 x 260-pin DDR4 SODIMM (up to 16 GB per socket)				
Display	Maximum Capacity	32GB				
	Chipset	Intel® HD Graphics 530, supports DirectX 12				
	VGA	1 x DB15, up to 2048 x 1536 maximum resolution				
	DVI	1 x DVI, up to 1920 x 1080 maximum resolution @ 30Mhz (with optional expansion cable for second DVI connector, or 1 x HDMI connector)				
	Multiple Display	Supports 3 x independent displays				
Ethernet	Controller	LAN1: Intel® i219-LM LAN2: Intel® i210 (supports wake-on-LAN)				
	Interface	2 x RJ45				
Storage	HDD/SSD	1 x 2.5" HDD/SSD				
	CFast	1				
	mSATA	1				
	RAID	0/1/5/10				
I/O	USB	8 x USB 3.0 and 1 x internal USB 2.0				
	Serial Port	2 x DB9, RS232/422/485 with automatic flow control and 4 x RS-232 (with expansion cable)				
	Audio	2 (1 x line out and 1 x mic in)				
Expansion	Module	Supports Advantech i-Modules				
	Mini PCIe	1 x mini PCIe (via USIM), 1 x mini PCIe/mSATA				
LED and Switch	LED	2 x TX, 2 x RX, and 1 x Storage				
	Button	1 x Power on/off switch				
Power	Type	ATX/AT				
	Input Voltage	9 ~ 36 V _{DC}				
Watchdog Timer	Output	System reset				
	Interval	Programmable 1 ~ 255 sec/min				
Environment	Temperature	i7-6820EQ Operating (with industrial SSD only)		Operating (with industrial SSD)	Operating (with HDD)	Non-operating
		-20 ~ 50 °C with 0.7 m/s air flow Note: MIC-7500 i7-6820EQ system support SSD only.		-20 ~ 60 °C with 0.7 m/s air flow	0 ~ 40 °C	-40 ~ 85 °C
	Humidity	95% @ 40 °C (non-condensing)				
	Vibration	With SSD: 3 Grms @ 5 ~ 500 Hz, random, 1 hr/axis			2G	
Mechanical	Shock	With SSD: 20G, IEC-68-2-27, half-sine wave, 11 ms duration			50G 11 ms	
	Dimensions (W x H x D)	73 x 192 x 230 mm (2.91" x 7.55" x 9.05")				
Certifications	Weight	2.9 kg (6.39 lbs)				
	Installation	Desktop/wall mount				
	EMC	CE/FCC Class A, CCC, BSMI				
	Safety	UL, CCC, BSMI				

Dimensions

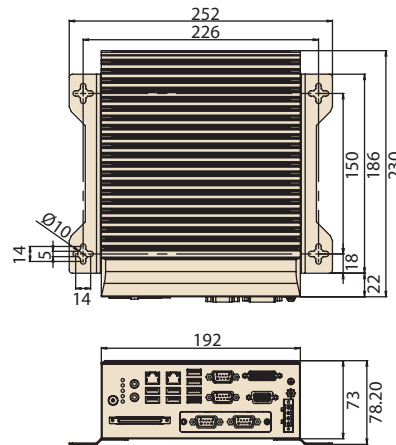
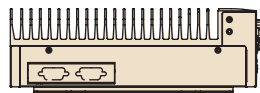
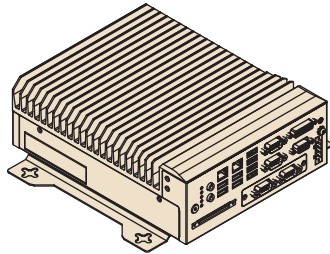

Unit: mm

Front View

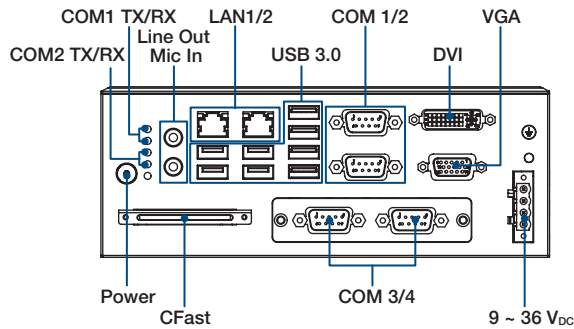

Side View

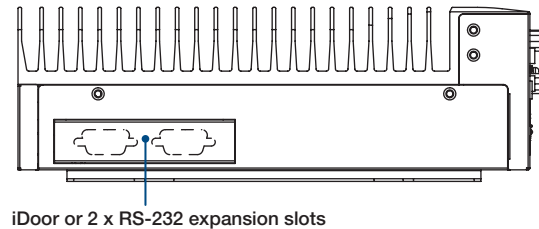

Ordering Information

Part Number	CPU	VGA	DVI	2.5" HDD/SSD	CFAST	mSATA	USB 3.0	GbE	COM	PCIe	Power
MIC-7500B-U8A1E	i7-6820EQ (45W)	1	1	1	1	1	8	2	4, up to 6 via cable	i-Module (optional)	9 ~ 36V _{DC}
MIC-7500B-U0A1E	i7-6822EQ	1	1	1	1	1	8	2	4, up to 6 via cable	i-Module (optional)	9 ~ 36V _{DC}
MIC-7500B-S9A1E	i5-6442EQ	1	1	1	1	1	8	2	4, up to 6 via cable	i-Module (optional)	9 ~ 36V _{DC}
MIC-7500B-19A1E	i3-6102E	1	1	1	1	1	8	2	4, up to 6 via cable	i-Module (optional)	9 ~ 36V _{DC}
MIC-7500B-U4A1E	G3900E (45W)	1	1	1	1	1	8	2	4, up to 6 via cable	i-Module (optional)	9 ~ 36V _{DC}

Packing List

Part Number	Description
MIC-7500	Fanless system with 6 th Gen Intel® Core™ i processor
2061750000	CD-ROM
2001750000	Startup manual
1652003234	4-pin Phoenix power connector
1960070543T001	2 x Mounting bracket
1700019445	SATA cable
1700024372-01	SATA power cable
1701200220	Dual DP9 port cable

Optional Accessories

Part Number	Description
96PSA-A220W24P4-1	Adaptor A/D, 100-240V, 220W, 24V
96PSA-A150W19P4-1	Adaptor A/D, 100-240V, 150W, 19V
1702002600	Power cord (USA) UL/CSA, 3-pin, 10A, 125V, 1.83 M, 180 D
1700022940-01	Power cord PSE, 3-pin, 7A, 125V, 3 m, DAC-ST01
1702002605	Power cord (EU) 2-pin, 10/16A, 220V, 1.83 M, 90 D
AIS-DIO32-00A1E	AIS GPIO module (32 bit)
PCA-TPM-00B1E	TPM 2.0 module
98R1750000E	Secondary DVI accessory kit
98R1750010E	HDMI/Remote power connector accessory kit
98R1750030E	HDMI accessory kit
98R1750020E	MIC-7000 series DIN rail accessory

Note:

- MIC-7500 supports Advantech's iDoor modules (both MOS and PCM series). Visit the Advantech website for more information.
- The PCM series module requires a bracket (P/N: 1960065854N001) that must be ordered separately.

Optional i-Modules*

Part Number	Description
MIC-75M40	4-slot expansion module (4 x PCIe slots)
MIC-75M13	4-slot expansion module (1 x PCIe and 3 x PCI slots)
MIC-75M20	2-slot expansion module (2 x PCIe slots)
MIC-75M20-01	2-slot expansion module (2xPCIe slots)
MIC-75M11	2-slot expansion module (1 x PCIe and 1 x PCI slots)
MIC-75M10	1-slot expansion module (1xPCIe16)
MIC-75S20	2-slot expansion and storage module (2 x PCIe and 2 x 2.5 hot swappable HDDs)

*Additional i-module details provided on the following page.

Embedded OS

Part Number	Description
2070014106	WES7P MIC-7500 x64 V5.6.6 10MUI image
2070014584	WES7P MIC-7500 x32 V5.3.0 10MUI image

i-Modules for MIC-7 Series

Compatible with MIC-7 Series Fanless Systems

4-Slot Expansion Modules

MIC-75M40

- 1 x PCIe x8
- 3 x PCIe x4
- 1 x SATA (2 x 2.5" HDD bays)
- Supports 1 x 8-cm fan (optional)
- Dimensions (W x H x D): 163 x 192 x 230 mm (6.41" x 7.55" x 9.05")

Note

- For expansion cards with more than 45W power consumption, a fan should be added for thermal management.
- MIC-75M40 does not support MIC-73 series systems or MIC-7700H.



MIC-75M13

- 1 x PCIe x16
- 3 x PCI
- 1 x SATA (2 x 2.5" HDD bays)
- Supports 1 x 8-cm fan (optional)
- Dimensions (W x H x D): 163 x 192 x 230 mm (6.41" x 7.55" x 9.05")

Note

- For expansion cards with more than 45W power consumption, a fan should be added for thermal management.
- For MIC-73 series systems (with Intel® Atom™ CPU), only 1 PCIe x4 is supported.



2-Slot Expansion Modules

MIC-75M20 MIC-75M20-01

- MIC-75M20: 1 x PCIe x16/1 x PCIe x4
- MIC-75M20-01: 2 x PCIe x8
- Supports 2 x 4-cm fans (optional)
- Dimensions (W x H x D): 123 x 192 x 230 mm (4.84" x 7.55" x 9.05")

Note

- For expansion cards with more than 45W power consumption, a fan should be added for thermal management.
- MIC-75M20 does not support MIC-73 series systems.
- MIC-75M20-01 does not support MIC-7700H.



MIC-75M11

- 1 x PCIe x16
- 1 x PCI
- Supports 2 x 4-cm fans (optional)
- Dimensions (W x H x D): 123 x 192 x 230 mm (4.84" x 7.55" x 9.05")

Note

- For expansion cards with more than 45W power consumption, a fan should be added for thermal management.
- MIC-73 series systems (with Intel® Atom™ CPU) support 1 PCIe x4 or 3 PCI sockets.



MIC-75S20

- 1 x PCIe x16
- 1 x PCIe x4
- 2 x Hot-swappable HDD trays (15 mm)
- Supports 1 x 8-cm fan (optional)
- Dimensions (W x H x D): 163 x 192 x 230 mm (6.41" x 7.55" x 9.05")

Note

- Install an SSD for wide temperature range. If the system does not feature an SSD, a fan should be added for thermal management.
- MIC-75S20 does not support high-power consumption expansion cards (i.e., graphics cards).
- MIC-75S20 does not support MIC-73 series systems.



MIC-75M10

- 1 x PCIe x16
- Dimensions (W x H x D): 97 x 192 x 230 mm (3.81" x 7.55" x 9.05")

Note

- MIC-75M10 does not support fan modules.
- MIC-75M10 does not support high-power consumption expansion cards (i.e., graphics cards).



Optional Accessories

Part Number	Description
98R1751300E	8-cm fan for 4-slot i-Modules
98R1752000E	2 x 4-cm fan for 2-slot i-Modules
98R1752010E	Secondary HDD bracket (for 2-slot i-Modules)

Ordering Information

Part Number	Description
MIC-75M13-00A1E	4-slot expansion i-Module with 1 PCIe x16, 3 PCI
MIC-75M40-00A1E	4-slot expansion i-Module with 1 PCIe x8, 3 PCIe x4
MIC-75M11-00A1E	2-slot expansion i-Module with 1 PCIe x16, 1 PCI
MIC-75M20-00A1E	2-slot expansion i-Module with 1 PCIe x16, 1 PCIe x4
MIC-75M10-00A1	1-slot expansion i-Module with 1 PCIe x16
MIC-75M20-01A1E	2-slot expansion i-Module with 2 PCIe x8
MIC-75S20-00A1E	2-slot expansion i-Module with 1 PCIe x16, 1 PCIe x4, 2 2.5" HDD bay



Стандарт Электрон Связь

Мы молодая и активно развивающаяся компания в области поставок электронных компонентов. Мы поставляем электронные компоненты отечественного и импортного производства напрямую от производителей и с крупнейших складов мира.

Благодаря сотрудничеству с мировыми поставщиками мы осуществляем комплексные и плановые поставки широчайшего спектра электронных компонентов.

Собственная эффективная логистика и склад в обеспечивает надежную поставку продукции в точно указанные сроки по всей России.

Мы осуществляем техническую поддержку нашим клиентам и предпродажную проверку качества продукции. На все поставляемые продукты мы предоставляем гарантию .

Осуществляем поставки продукции под контролем ВП МО РФ на предприятия военно-промышленного комплекса России , а также работаем в рамках 275 ФЗ с открытием отдельных счетов в уполномоченном банке. Система менеджмента качества компании соответствует требованиям ГОСТ ISO 9001.

Минимальные сроки поставки, гибкие цены, неограниченный ассортимент и индивидуальный подход к клиентам являются основой для выстраивания долгосрочного и эффективного сотрудничества с предприятиями радиоэлектронной промышленности, предприятиями ВПК и научно-исследовательскими институтами России.

С нами вы становитесь еще успешнее!

Наши контакты:

Телефон: +7 812 627 14 35

Электронная почта: sales@st-electron.ru

Адрес: 198099, Санкт-Петербург,
Промышленная ул, дом № 19, литера Н,
помещение 100-Н Офис 331