

Other Information

To obtain the most recent and complete documentation for this demonstration board, including:

- User's Guide
- Board Description
- Board Schematics
- Source Code
- Application Examples
- Links to Web Seminars

please refer to the web sites: <http://www.microchip.com/tcpip>

<http://www.microchip.com/Ethernet>

Americas

Atlanta (770) 640-0034
Boston (774) 760-0087
Chicago (630) 285-0071
Dallas (972) 818-7423
Detroit (248) 538-2250
Kokomo (765) 864-8360
Los Angeles (949) 462-9523
Phoenix (480) 792-7200
San Jose (650) 215-1444
Toronto (905) 673-0699

Asia/Pacific

Australia - Sydney 61-2-9868-6733
China - Beijing 86-10-8528-2100
China - Chengdu 86-28-8676-6200
China - Fuzhou 86-591-8750-3506
China - Hong Kong SAR 852-2401-1200
China - Qingdao 86-532-8502-7355
China - Shanghai 86-21-5407-5533
China - Shenyang 86-24-2334-2829
China - Shenzhen 86-755-8203-2660
China - Shunde 86-757-2839-5507
China - Wuhan 86-27-5980-5300
China - Xian 86-29-8833-7250
India - Bangalore 91-80-4182-8400
India - New Delhi 91-11-5160-8631
India - Pune 91-20-2566-1512
Japan - Yokohama 81-45-471-6166
Korea - Gumi 82-54-473-4301
Korea - Seoul 82-2-554-7200

Asia/Pacific

Malaysia - Penang 60-4-646-8870
Philippines - Manila 63-2-634-9065
Singapore 65-6334-8870
Taiwan - Hsin Chu 886-3-572-9526
Taiwan - Kaohsiung 886-7-536-4818
Taiwan - Taipei 886-2-2500-6610
Thailand - Bangkok 66-2-694-1351

Europe

Austria - Wels 43-7242-2244-3910
Denmark - Copenhagen 45-4450-2828
France - Paris 33-1-69-53-63-20
Germany - Munich 49-89-627-144-0
Italy - Milan 39-0331-742611
Netherlands - Drunen 31-416-690399
Spain - Madrid 34-91-708-08-90
UK - Wokingham 44-118-921-5869

As of 06/08/06



MICROCHIP

Microchip Technology Inc. • 2355 West Chandler Blvd. • Chandler, AZ 85224-6199
www.microchip.com

The Microchip name and logo, the Microchip logo, PIC and PICmicro are registered trademarks of Microchip Technology Incorporated in the U.S.A. and other countries. In-Circuit Serial Programming, ICSP, PICDEM and PICtail are trademarks of Microchip Technology Incorporated in the U.S.A. and other countries. All other trademarks mentioned herein are property of their respective companies. © 2006, Microchip Technology Incorporated, Printed in the U.S.A. All Rights Reserved. 7/06



DS51602B

Ethernet PICtail™ Plus Daughter Board

Overview

The Ethernet PICtail™ Plus Daughter Board is an Ethernet demonstration board for evaluating Microchip Technology's ENC28J60 stand-alone 10Base-T Ethernet controller. It is an expansion board compatible with the Explorer 16 development board.

Features

- ENC28J60 Ethernet Controller with 25 MHz oscillator and integrated, magnetic RJ-45 connector (see device data sheet, DS39662, for additional information)
- PICtail™ Plus Daughter Board connection interface

Please see reverse side for schematic.

Getting Started

To get started, an Explorer 16 development board is required. All Explorer 16 development boards are shipped with connector J5 installed. The Ethernet PICtail Plus Daughter Board should be inserted into the top most socket of J5. The orientation of the Ethernet PICtail Plus Daughter Board should be such that the RJ-45 socket points toward the prototyping area on the Explorer 16 development board. It is possible to insert the Ethernet PICtail Plus Daughter Board into the second top most socket of J5 and use the second SPI module; however, pin remapping in the example firmware will be required.

TCP/IP Stack and Firmware

The Microchip TCP/IP stack and other firmware examples can be downloaded from <http://www.microchip.com/Ethernet>, then select "TCP/IP Stack", or go directly to <http://www.microchip.com/tcpip>. Make sure to download the firmware version that has been designated for the Explorer 16 development board.

Signal Interface

Function	I/O	Pin	Description
CS	I	RD14/U1CTS_E	SPI Chip Select
SCK	I	RF6/SCK1	SPI Clock
SO	O	RF7/SDI1_E	SPI Data Out from ENC28J60
SI	I	RF8/SDO1_E	SPI Data In to ENC28J60
INT	O	RE9/INT2	INT Interrupt Signal

Note: Input signal, $\overline{\text{RESET}}$, is optional. Install R10 with a 180 ohm resistor to use this signal. The corresponding pin on the Explorer 16 development board is RD15/U1RTS_E.

Media Access Control (MAC) Address

For evaluation purposes, each Ethernet PICtail Plus Daughter Board comes with a board number which can be used to form a unique MAC address. This number can be found on the sticker label on each board. To form a MAC address, replace the last 3 bytes of the following MAC address, 00-04-A3-XX-XX-XX, with the number from the sticker. The number on the sticker is in decimal format and conversion to a hex number is required. For example, if the sticker has the value of "12345", then the MAC address would be 00-04-A3-00-30-39.

Ethernet PICtail™ Plus Daughter Board

Board Schematic

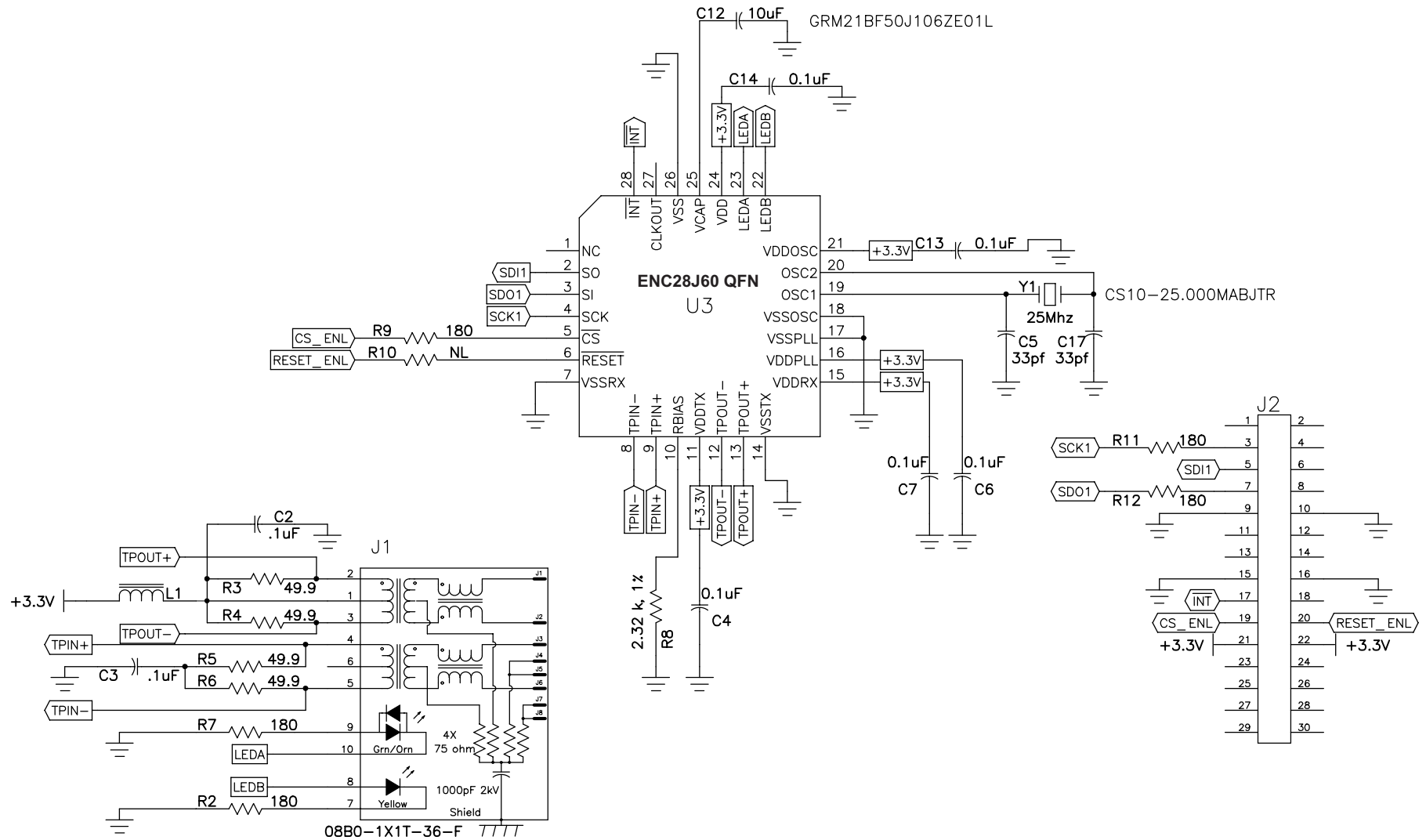

03-01898 Rev. 4

DS51602B



Стандарт Электрон Связь

Мы молодая и активно развивающаяся компания в области поставок электронных компонентов. Мы поставляем электронные компоненты отечественного и импортного производства напрямую от производителей и с крупнейших складов мира.

Благодаря сотрудничеству с мировыми поставщиками мы осуществляем комплексные и плановые поставки широчайшего спектра электронных компонентов.

Собственная эффективная логистика и склад в обеспечивает надежную поставку продукции в точно указанные сроки по всей России.

Мы осуществляем техническую поддержку нашим клиентам и предпродажную проверку качества продукции. На все поставляемые продукты мы предоставляем гарантию .

Осуществляем поставки продукции под контролем ВП МО РФ на предприятия военно-промышленного комплекса России , а также работаем в рамках 275 ФЗ с открытием отдельных счетов в уполномоченном банке. Система менеджмента качества компании соответствует требованиям ГОСТ ISO 9001.

Минимальные сроки поставки, гибкие цены, неограниченный ассортимент и индивидуальный подход к клиентам являются основой для выстраивания долгосрочного и эффективного сотрудничества с предприятиями радиоэлектронной промышленности, предприятиями ВПК и научно-исследовательскими институтами России.

С нами вы становитесь еще успешнее!

Наши контакты:

Телефон: +7 812 627 14 35

Электронная почта: sales@st-electron.ru

Адрес: 198099, Санкт-Петербург,
Промышленная ул, дом № 19, литера Н,
помещение 100-Н Офис 331