

# NHD-C160100DiZ-FSW-FBW

## COG (Chip-On-Glass) Liquid Crystal Display Module

NHD-	Newhaven Display
C160100-	160 x 100 pixels
DiZ-	Model (I2C)
F-	Transflective
SW-	Side White LED backlight
F-	FSTN (+)
B-	6:00 view
W-	Wide Temp (-20°C ~ +70°C)
	<b>RoHS Compliant</b>

**Newhaven Display International, Inc.**

2511 Technology Drive, Suite 101

Elgin IL, 60124

Ph: 847-844-8795

Fax: 847-844-8796

[www.newhavendisply.com](http://www.newhavendisply.com)

[nhtech@newhavendisply.com](mailto:nhtech@newhavendisply.com)

[nhsales@newhavendisply.com](mailto:nhsales@newhavendisply.com)

## Document Revision History

Revision	Date	Description	Changed by
0	1/06/2008	Initial Release	-
1	9/18/2009	User guide reformat	BE
2	10/14/2009	Updated Electrical Characteristic	MC
3	11/9/2009	Slave Address Updated	BE
4	11/17/2009	Slave Address Updated	MC
5	11/20/2009	Updated backlight supply current max / Updated Table of Commands	MC
6	12/14/2010	Updated backlight cable length	CL

## Functions and Features

- 160 x 100 pixels
- Built-in ST7528i (I2C) controller
- +3.0V power supply
- 1/100 duty cycle; 1/11 bias
- RoHS Compliant

# Mechanical Drawing

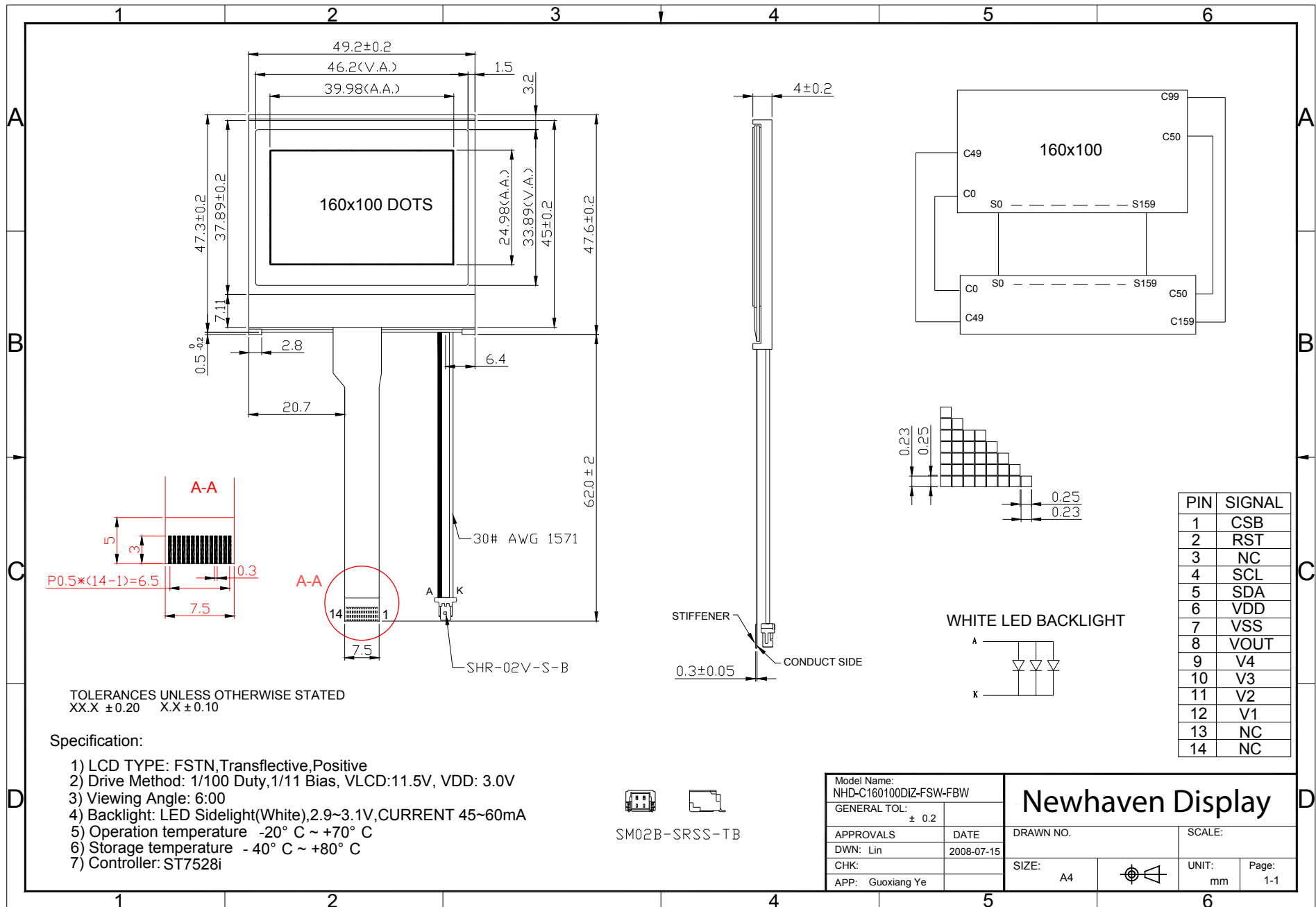

Model Name: NHD-C160100DIZ-FSW-FBW	
GENERAL TOL: ± 0.2	
APPROVALS	DATE
DWN: Lin	2008-07-15
CHK:	
APP: Guoxiang Ye	

Newhaven Display		DRAWN NO.		SCALE:	
		SIZE: A4		UNIT: mm Page: 1-1	

## Pin Description and Wiring Diagram

Pin No.	Symbol	External Connection	Function Description
1	CSB	MPU	Active Low chip select
2	RST	MPU	Active Low Reset signal
3	NC	-	No Connect
4	SCL	MPU	Serial clock input (requires pull-up)
5	SDA	MPU	Serial data input (requires pull-up)
6	VDD	Power Supply	Power supply for LCD and logic (+3.0V)
7	Vss	Power Supply	Ground
8	VOOUT	Power Supply	Connect to 1uF cap to VSS or VDD
9	V4	Power Supply	1.0uF-2.2uF cap to Vss
10	V3	Power Supply	1.0uF-2.2uF cap to Vss
11	V2	Power Supply	1.0uF-2.2uF cap to Vss
12	V1	Power Supply	1.0uF-2.2uF cap to Vss
13	NC	-	No Connect
14	NC	-	No Connect

**Recommended LCD connector:** 0.5mm pitch pins. Molex p/n: 52892-1495

**Backlight connector:** SHR-02V-S-B **Mates with:** SM02B-SRSS-TB

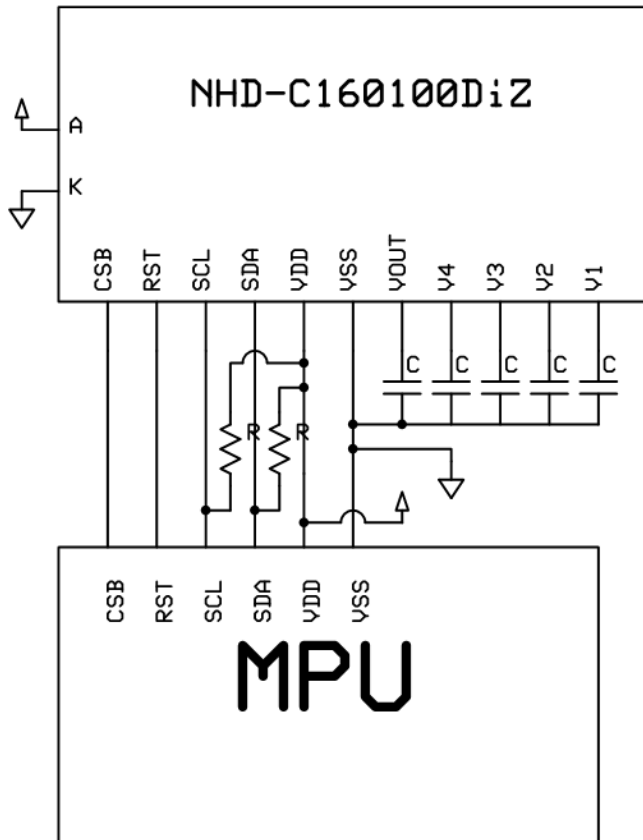

## Electrical Characteristics

Item	Symbol	Condition	Min.	Typ.	Max.	Unit
Operating Temperature Range	Top	Absolute Max	-20	-	+70	°C
Storage Temperature Range	Tst	Absolute Max	-40	-	+80	°C
Supply Voltage	VDD		2.4	3.0	3.3	V
Supply Current	IDD	Ta=25°C, VDD=3.0V	-	500	-	uA
Supply for LCD (contrast)	VDD-V0	Ta=25°C	-	11.5	-	V
"H" Level input	Vih		2.2	-	VDD	V
"L" Level input	Vil		0	-	0.6	V
"H" Level output	Voh		2.4	-	-	V
"L" Level output	Vol		-	-	0.4	V
Backlight Supply Voltage	VLED		-	3.0	-	V
Backlight Supply current	ILED	VLED=3.0V	-	45	60	mA

## Optical Characteristics

Item	Symbol	Condition	Min.	Typ.	Max.	Unit
Viewing Angle - Vertical	$\theta$	Cr≥3	-20	-	+40	°
Viewing Angle - Horizontal	$\Phi$		-35	-	+35	°
Contrast Ratio	CR		-	10	-	-
Response Time (rise)	Tr	-	-	200	250	ms
Response Time (fall)	Tf	-	-	300	350	ms

## Controller Information

Built-in ST7528. Download specification at [http://www.newhavendisplay.com/app\\_notes/ST7528.pdf](http://www.newhavendisplay.com/app_notes/ST7528.pdf)

## I2C Interface:

I2C interface requires 2 lines, Serial Data and Serial Clock. Both lines must be connected to the positive supply via a pull-up resistor. Data transfer may be initiated only when the bus is not busy.

### Bit transfer:

One data bit is transferred during each clock pulse. The data on the SDA line must remain stable during the HIGH period of the clock pulse, changes in the data line at this time will be interpreted as a control signal.

### Start and Stop conditions:

Both data and clock lines remain HIGH when the bus is not busy. A HIGH-to-LOW transition of the data line while the clock is HIGH is define as the START condition. A LOW-to-HIGH transition of the data line while the clock is HIGH is defined as the STOP condition.

### Acknowledge:

Each byte of eight bits is followed by an acknowledge bit. The ACK bit is a HIGH signal put on the bus by the transmitter, during which time the master generates an extra ACK related clock pulse. The LCD generates an ACK after the reception of each byte. The LCD will pull-down the SDA line during the ACK clock pulse, so that the SDA line is stable LOW during the HIGH period of the ACK clock pulse.

## Slave Address = 0x3F

## Timing Characteristics

Write mode

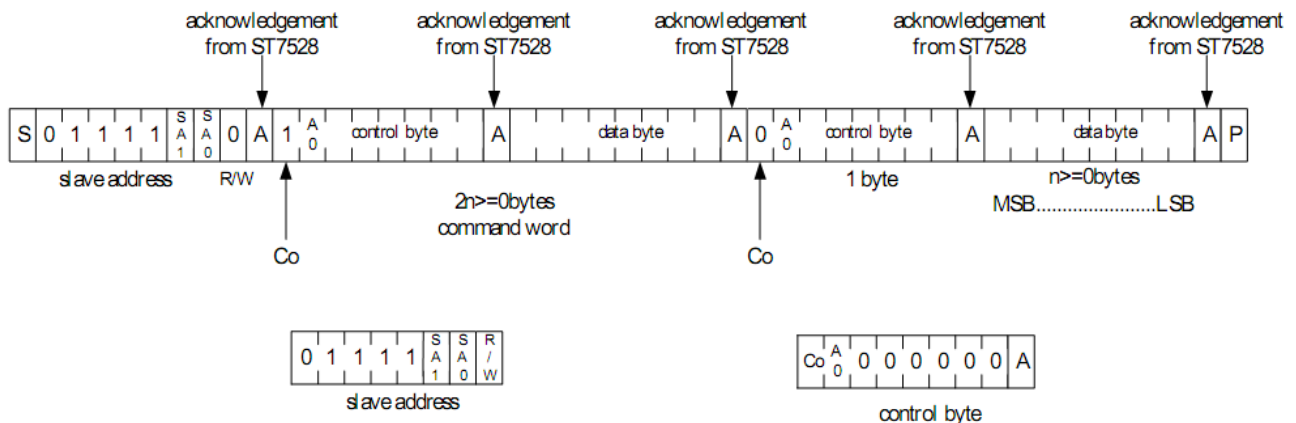

Co	0	Last control byte to be sent. Only a stream of data bytes is allowed to follow. This stream may only be terminated by a STOP or RE-START condition.
	1	Another control byte will follow the data byte unless a STOP or RE-START condition is received.

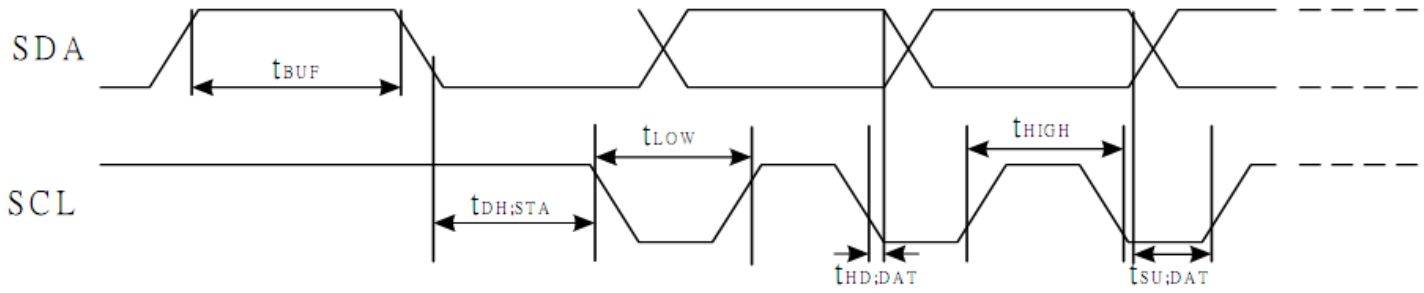

( $V_{DD}=3.3V, T_a=25^{\circ}C$ )

Item	Signal	Symbol	Condition	Rating		Units
				Min.	Max.	
SCL clock frequency	SCL	FCLK		-	400	kHZ
SCL clock low period	SCL	TLOW		1.3	-	us
SCL clock high period	SCL	THIGH		0.6	-	us
Data set-up time	SI	TSU;Data		100	-	ns
Data hold time	SI	THD;Data		0	0.9	us
SCL,SDA rise time	SCL	TR		$20+0.1C_b$	300	ns
SCL,SDA fall time	SCL	TF		$20+0.1C_b$	300	ns
Capacitive load represented by each bus line		$C_b$		-	400	pF
Setup time for a repeated START condition	SI	TSU;SUA		0.6	-	us
Start condition hold time	SI	THD;STA		0.6	-	us
Setup time for STOP ondition		TSU;STO		0.6	-	us
Tolerable spike width on bus		TSW		-	50	ns
BUS free time between a STOP and StART condition	SCL	TBUF		1.3		us

## Table of Commands

Instruction	A0	RW	DB7	DB6	DB5	DB4	DB3	DB2	DB1	DB0	Description
<b>EXT=0 or 1</b>											
Mode Set	0	0	0	0	1	1	1	0	0	0	2-byte instruction to set Mode and FR( Frame frequency control) BE( Booster efficiency control)
	0	0	FR3	FR2	FR1	FR0	0	BE	x'	EXT	
<b>EXT=0</b>											
Read display data	1	1	Read data							Read data into DDRAM	
Write display data	1	0	Write data							Write data into DDRAM	
Read status	0	1	BUSY	ON	RES	MF2	MF1	MF0	DS1	DS0	Read the internal status
ICON control register ON/OFF	0	0	1	0	1	0	0	0	1	ICON	ICON=0: ICON disable(default) ICON=1: ICON enable & set the page address to 16
Set page address	0	0	1	0	1	1	P3	P2	P1	P0	Set page address
Set column address MSB	0	0	0	0	0	1	Y9	Y8	Y7	Y6	Set column address MSB
Set column address LSB	0	0	0	0	0	0	Y5	Y4	Y3	Y2	Set column address LSB
Set modify-read	0	0	1	1	1	0	0	0	0	0	Set modify-read mode
Reset modify-read	0	0	1	1	1	0	1	1	1	0	release modify-read mode
Display ON/OFF	0	0	1	0	1	0	1	1	1	D	D=0: Display OFF D=1: Display ON
Set initial display line register	0	0	0	1	0	0	0	0	x'	x'	2-byte instruction to specify the initial display line to realize vertical scrolling
	0	0	x'	S6	S5	S4	S3	S2	S1	S0	
Set initial COM0 register	0	0	0	1	0	0	0	1	x'	x'	2-byte instruction to specify the initial COM0 to realize window scrolling
	0	0	x'	C6	C5	C4	C3	C2	C1	C0	
Set partial display duty ration	0	0	0	1	0	0	1	0	x'	x'	2-byte instruction to set partial display duty ratio
	0	0	D7	D6	D5	D4	D3	D2	D1	D0	
Set N-line inversion	0	0	0	1	0	0	1	1	x'	x'	2-byte instruction to set N-line inversion register
	0	0	x'	x'	x'	N4	N3	N2	N1	N0	
Release N-line inversion	0	0	1	1	1	0	0	1	0	0	Release N-line inversion mode
Reverse display ON/OFF	0	0	1	0	1	0	0	1	1	REV	REV=0: normal display REV=1: reverse display
Entire display ON/OFF	0	0	1	0	1	0	0	1	0	EON	EON=0: normal display EON=1: entire display ON



# ST7528

Instruction	A0	RW	DB7	DB6	DB5	DB4	DB3	DB2	DB1	DB0	Description
<b>Ext=0</b>											
Power control	0	0	0	0	1	0	1	VC	VR	VF	Control power circuit operation
Select DC-DC step-up	0	0	0	1	1	0	0	1	DC1	DC0	Select the step-up of internal voltage converter
Select regulator register	0	0	0	0	1	0	0	R2	R1	R0	Select the internal resistance ratio of the regulator resistor
Select electronic volumn register	0	0	1	0	0	0	0	0	0	1	2-byte instruction to specify the reference voltage
	0	0	x'	x'	EV5	EV4	EV3	EV2	EV1	EV0	
Select LCD bias	0	0	0	1	0	1	0	B2	B1	B0	Select LCD bias
Bias Power Save	0	0	1	1	1	1	0	0	1	1	Bias Power save
	0	0	0	0	0	0	0	0	0	0	Save the Bias current consumption
SHL select	0	0	1	1	0	0	SHL	x'	x'	x'	COM bi-directional selection SHL=0: normal direction SHL=1: reverse direction
ADC select	0	0	1	0	1	0	0	0	0	ADC	SEG bi-direction selection ADC=0: normal direction ADC=1: reverse direction
Oscillator on start	0	0	1	0	1	0	1	0	1	1	Start the built-in oscillator
Set power save mode	0	0	1	0	1	0	1	0	0	P	P=0: normal mode P=1: sleep mode
Release power save mode	0	0	1	1	1	0	0	0	0	1	release power save mode
Reset	0	0	1	1	1	0	0	0	1	0	initial the internal function
Set data direction & display data length(DDL)	x	x'	1	1	1	0	1	0	0	0	2-byte instruction to specify the number of data bytes. (SPI mode)
	x	x'	D7	D6	D5	D4	D3	D2	D1	D0	
Select FRC and PWM mode	0	0	1	0	0	1	0	FRC	PWM1	PWM0	FRC(1:3FRC, 0:4FRC) PWM1 PWM0 0 0 45PWM 0 1 45 PWM 1 0 60PWM 1 1 ---
NOP	0	0	1	1	1	0	0	0	1	1	<u>No operation</u>
Test Instruction	0	0	1	1	1	1	x'	x'	x'	x'	<u>Don't use this instruction</u>

Instruction	A0	RW	DB7	DB6	DB5	DB4	DB3	DB2	DB1	DB0	Description
<b>EXT=1</b>											
Set white mode and 1 <sup>st</sup> frame, set pulse width	0	0	1	0	0	0	0	0	0	0	Set white mode and 1st frame
	0	0	X'	X'	GA05	GA04	GA03	GA02	GA01	GA00	
Set white mode and 2 <sup>nd</sup> frame, set pulse width	0	0	1	0	0	0	0	0	0	1	Set white mode and 2nd frame
	0	0	X'	X'	GA05	GA04	GA03	GA02	GA01	GA00	
Set white mode and 3 <sup>rd</sup> frame, set pulse width	0	0	1	0	0	0	0	0	1	0	Set white mode and 3rd frame
	0	0	X'	X'	GA05	GA04	GA03	GA02	GA01	GA00	
Set white mode and 4 <sup>th</sup> frame, set pulse width	0	0	1	0	0	0	0	0	1	1	Set white mode and 4th frame
	0	0	X'	X'	GA05	GA04	GA03	GA02	GA01	GA00	
Set gray level 1 mode	0	0	84H~87H (4 bytes)								Set gray level1
Set gray level 2 mode	0	0	88H~8BH (4 bytes)								Set gray level2
Set gray level 3 mode	0	0	8CH~8FH (4bytes)								Set gray level3
Set gray level 4 mode	0	0	90H~93H (4bytes)								Set gray level4
Set gray level 5 mode	0	0	94H~97H (4bytes)								Set gray level5
Set gray level 6 mode	0	0	98H~9BH (4 bytes)								Set gray level6
Set gray level 7 mode	0	0	9CH~9FH (4 bytes)								Set gray level7
Set gray level 8 mode	0	0	A0H~A3H (4 bytes)								Set gray level8
Set gray level 9 mode	0	0	A4H~A7H (4 bytes)								Set gray level9
Set gray level 10 mode	0	0	A8H~ABH (4 bytes)								Set gray level10
Set gray level 11mode	0	0	ACH~AFH (4 bytes)								Set gray level11
Set gray level 12 mode	0	0	B0H~B3H (4 bytes)								Set gray level12
Set gray level 13 mode	0	0	B4H~B7H (4 bytes)								Set gray level13
Set gray level 14 mode	0	0	B8H~BBH (4 bytes)								Set gray level14
Set Dark mode and 1st frame, set pulse width	0	0	1	0	1	1	1	1	0	0	Set Dark mode and 1st frame, set pulse width
	0	0	X'	X'	GAF5	GAF4	GAF3	GAF2	GAF1	GAF0	
Set Dark mode and 2nd frame, set pulse width	0	0	1	0	1	1	1	1	0	1	Set Dark mode and 2nd frame, set pulse width
	0	0	X'	X'	GAF5	GAF4	GAF3	GAF2	GAF1	GAF0	
Set Dark mode and 3rd frame, set pulse width	0	0	1	0	1	1	1	1	1	0	Set Dark mode and 3rd frame, set pulse width
	0	0	X'	X'	GAF5	GAF4	GAF3	GAF2	GAF1	GAF0	
Set Dark mode and 4th frame, set pulse width	0	0	1	0	1	1	1	1	1	1	Set Dark mode and 4th frame, set pulse width
	0	0	X'	X'	GAF5	GAF4	GAF3	GAF2	GAF1	GAF0	

# Example Initialization Program

## Slave Address = 0x3F

```
/******  
const char Slave = 0x7E; //slave address+Write bit  
const char Comsend = 0x00;  
const char Datasend = 0x40;  
/******  
void I2C_out(unsigned char j) //I2C Output  
{  
    int n;  
    unsigned char d;  
    d=j;  
    for(n=0;n<8;n++){ //send 8 bits  
        if((d&0x80)==0x80) //get only the MSB  
            SDA=1; //if 1, then SDA=1  
        else //if 0, then SDA=0  
            SDA=0; //shift data byte left  
        d=(d<<1);  
        SCL = 0;  
        SCL = 1; //clock in data  
        SCL = 0;  
    }  
    SCL = 1;  
    while(SDA==1){ //wait here until ACK  
        SCL=0;  
        SCL=1;  
    }  
    SCL=0;  
}  
/******  
void I2C_Start(void)  
{  
    SCL=1;  
    SDA=1;  
    SDA=0;  
    SCL=0;  
}  
/******  
void I2C_Stop(void)  
{  
    SDA=0;  
    SCL=0;  
    SCL=1;  
    SDA=1;  
}  
/******  
void Show(unsigned char *text)  
{  
    int n,i;  
    char page=0xB0; //first page  
    for(i=0;i<13;i++){ //100 pixels = 12.5 pixels  
        I2C_Start();  
        I2C_out(Slave);  
        I2C_out(Comsend);  
    }  
}
```

```

        I2C_out(page);
        I2C_out(0x10);           //column address Y9:Y6
        I2C_out(0x01);         //column address Y5:Y2
        I2C_Stop();
        I2C_Start();
        I2C_out(Slave);
        I2C_out(Datasend);
        for(n=0;n<160;n++){
            I2C_out(*text);     //send data 4 times for grayscaling
            I2C_out(*text);
            I2C_out(*text);
            I2C_out(*text);
            ++text;             //point to next byte of data
            delay(10);
        }
        I2C_Stop();
        page++;                 //move to next page
    }
}
/*****
*      Initialization      *
*****/
void init_LCD()
{
    I2C_Start();
    I2C_out(Slave);
    I2C_out(Comsend);
    I2C_out(0x48);             //partial display duty ratio
    I2C_out(0x64);             // 1/100 duty
    I2C_out(0xA0);             //ADC select
    I2C_out(0xC8);             //SHL select
    I2C_out(0x44);             //initial Com0 register
    I2C_out(0x00);             //scan from Com0
    I2C_out(0xAB);             //OSC on
    I2C_out(0x26);             //
    I2C_out(0x81);             //set electronic volume
    I2C_out(0x15);             //vopcode=0x1C
    I2C_out(0x56);             //set 1/11 bias
    I2C_out(0x64);             //3x
    delay(2);
    I2C_out(0x2C);             //
    I2C_out(0x66);             //5x
    delay(2);
    I2C_out(0x2E);             //
    delay(2);
    I2C_out(0x2F);             //power control
    I2C_out(0xF3);             //bias save circuit
    I2C_out(0x00);             //
    I2C_out(0x96);             //frc and pwm
    I2C_out(0x38);             //external mode
    I2C_out(0x75);             //
    I2C_out(0x97);             //3frc, 45 pwm
    I2C_out(0x80);             //start 16-level grayscale settings
    I2C_out(0x00);             //
    I2C_out(0x81);             //
    I2C_out(0x00);             //
    I2C_out(0x82);             //
    I2C_out(0x00);             //
    I2C_out(0x83);             //
    I2C_out(0x00);             //
    I2C_out(0x84);             //
    I2C_out(0x06);             //
    I2C_out(0x85);             //

```

```
I2C_out(0x06); //
I2C_out(0x86); //
I2C_out(0x06); //
I2C_out(0x87); //
I2C_out(0x06); //
I2C_out(0x88); //
I2C_out(0x0B); //
I2C_out(0x89); //
I2C_out(0x0B); //
I2C_out(0x8A); //
I2C_out(0x0B); //
I2C_out(0x8B); //
I2C_out(0x0B); //
I2C_out(0x8C); //
I2C_out(0x10); //
I2C_out(0x8D); //
I2C_out(0x10); //
I2C_out(0x8E); //
I2C_out(0x10); //
I2C_out(0x8F); //
I2C_out(0x10); //
I2C_out(0x90); //
I2C_out(0x15); //
I2C_out(0x91); //
I2C_out(0x15); //
I2C_out(0x92); //
I2C_out(0x15); //
I2C_out(0x93); //
I2C_out(0x15); //
I2C_out(0x94); //
I2C_out(0x1A); //
I2C_out(0x95); //
I2C_out(0x1A); //
I2C_out(0x96); //
I2C_out(0x1A); //
I2C_out(0x97); //
I2C_out(0x1A); //
I2C_out(0x98); //
I2C_out(0x1E); //
I2C_out(0x99); //
I2C_out(0x1E); //
I2C_out(0x9A); //
I2C_out(0x1E); //
I2C_out(0x9B); //
I2C_out(0x1E); //
I2C_out(0x9C); //
I2C_out(0x23); //
I2C_out(0x9D); //
I2C_out(0x23); //
I2C_out(0x9E); //
I2C_out(0x23); //
I2C_out(0x9F); //
I2C_out(0x23); //
I2C_out(0xA0); //
I2C_out(0x27); //
I2C_out(0xA1); //
I2C_out(0x27); //
I2C_out(0xA2); //
I2C_out(0x27); //
I2C_out(0xA3); //
I2C_out(0x27); //
I2C_out(0xA4); //
I2C_out(0x2B); //
```

```

I2C_out(0xA5);      //
I2C_out(0x2B);     //
I2C_out(0xA6);     //
I2C_out(0x2B);     //
I2C_out(0xA7);     //
I2C_out(0x2B);     //
I2C_out(0xA8);     //
I2C_out(0x2F);     //
I2C_out(0xA9);     //
I2C_out(0x2F);     //
I2C_out(0xAA);     //
I2C_out(0x2F);     //
I2C_out(0xAB);     //
I2C_out(0x2F);     //
I2C_out(0xAC);     //
I2C_out(0x32);     //
I2C_out(0xAD);     //
I2C_out(0x32);     //
I2C_out(0xAE);     //
I2C_out(0x32);     //
I2C_out(0xAF);     //
I2C_out(0x32);     //
I2C_out(0xB0);     //
I2C_out(0x35);     //
I2C_out(0xB1);     //
I2C_out(0x35);     //
I2C_out(0xB2);     //
I2C_out(0x35);     //
I2C_out(0xB3);     //
I2C_out(0x35);     //
I2C_out(0xB4);     //
I2C_out(0x38);     //
I2C_out(0xB5);     //
I2C_out(0x38);     //
I2C_out(0xB6);     //
I2C_out(0x38);     //
I2C_out(0xB7);     //
I2C_out(0x38);     //
I2C_out(0xB8);     //
I2C_out(0x3A);     //
I2C_out(0xB9);     //
I2C_out(0x3A);     //
I2C_out(0xBA);     //
I2C_out(0x3A);     //
I2C_out(0xBB);     //
I2C_out(0x3A);     //
I2C_out(0xBC);     //
I2C_out(0x3C);     //
I2C_out(0xBD);     //
I2C_out(0x3C);     //
I2C_out(0xBF);     //
I2C_out(0x3C);     //
I2C_out(0xBF);     //
I2C_out(0x3C);     //end grayscale settings
I2C_out(0x38);     //
I2C_out(0x74);     //
I2C_out(0xAF);     //display on
I2C_Stop();
}
/*****

```

## Quality Information

Test Item	Content of Test	Test Condition	Note
High Temperature storage	Endurance test applying the high storage temperature for a long time.	+80°C , 48hrs	2
Low Temperature storage	Endurance test applying the low storage temperature for a long time.	-30°C , 48hrs	1,2
High Temperature Operation	Endurance test applying the electric stress (voltage & current) and the high thermal stress for a long time.	+70°C 48hrs	2
Low Temperature Operation	Endurance test applying the electric stress (voltage & current) and the low thermal stress for a long time.	-20°C , 48hrs	1,2
High Temperature / Humidity Operation	Endurance test applying the electric stress (voltage & current) and the high thermal with high humidity stress for a long time.	+40°C , 90% RH , 48hrs	1,2
Thermal Shock resistance	Endurance test applying the electric stress (voltage & current) during a cycle of low and high thermal stress.	-0°C,30min -> 25°C,5min -> 50°C,30min = 1 cycle 10 cycles	
Vibration test	Endurance test applying vibration to simulate transportation and use.	10-55Hz , 15mm amplitude. 60 sec in each of 3 directions X,Y,Z For 15 minutes	3
Static electricity test	Endurance test applying electric static discharge.	VS=800V, RS=1.5kΩ, CS=100pF One time	

**Note 1:** No condensation to be observed.

**Note 2:** Conducted after 4 hours of storage at 25°C, 0%RH.

**Note 3:** Test performed on product itself, not inside a container.

## Precautions for using LCDs/LCMs

See Precautions at [www.newhavendisplay.com/specs/precautions.pdf](http://www.newhavendisplay.com/specs/precautions.pdf)

## Warranty Information and Terms & Conditions

[http://www.newhavendisplay.com/index.php?main\\_page=terms](http://www.newhavendisplay.com/index.php?main_page=terms)



## Стандарт Электрон Связь

Мы молодая и активно развивающаяся компания в области поставок электронных компонентов. Мы поставляем электронные компоненты отечественного и импортного производства напрямую от производителей и с крупнейших складов мира.

Благодаря сотрудничеству с мировыми поставщиками мы осуществляем комплексные и плановые поставки широчайшего спектра электронных компонентов.

Собственная эффективная логистика и склад в обеспечивает надежную поставку продукции в точно указанные сроки по всей России.

Мы осуществляем техническую поддержку нашим клиентам и предпродажную проверку качества продукции. На все поставляемые продукты мы предоставляем гарантию .

Осуществляем поставки продукции под контролем ВП МО РФ на предприятия военно-промышленного комплекса России , а также работаем в рамках 275 ФЗ с открытием отдельных счетов в уполномоченном банке. Система менеджмента качества компании соответствует требованиям ГОСТ ISO 9001.

Минимальные сроки поставки, гибкие цены, неограниченный ассортимент и индивидуальный подход к клиентам являются основой для выстраивания долгосрочного и эффективного сотрудничества с предприятиями радиоэлектронной промышленности, предприятиями ВПК и научно-исследовательскими институтами России.

С нами вы становитесь еще успешнее!

### Наши контакты:

**Телефон:** +7 812 627 14 35

**Электронная почта:** [sales@st-electron.ru](mailto:sales@st-electron.ru)

**Адрес:** 198099, Санкт-Петербург,  
Промышленная ул, дом № 19, литера Н,  
помещение 100-Н Офис 331