



# GPS Receivers A2200-A

A Description of Maestro's  
GPS Receiver Module A2200-A

## User Manual

Version 1.0



## Revision History

Rev.	Date	Description
0.1	07-11-11	First draft, based on A2200
1.0	12-12-11	Updated photo ,Pin out Information,Packing
	mm-dd-yy	

	Name	Date	Signature
Written by	Happy wen	12-12-11	H W
Checked by	Sam Law, Wallace Lee	12-12-11	S L,W L
Approval by	Frank Tang, Calvin Yau	12-12-11	F T,C Y

## Disclaimer

THIS DOCUMENT CONTAINS PROPRIETARY INFORMATION OF MAESTRO WIRELESS SOLUTIONS LIMITED. IT MAY NOT BE COPIED OR TRANSMITTED BY ANY MEANS, PASSED TO OTHERS, OR STORED IN ANY RETRIEVAL SYSTEM OR MEDIA, WITHOUT PRIOR CONSENT OF MAESTRO OR ITS AUTHORIZED AGENTS.

THE INFORMATION IN THIS DOCUMENT IS, TO THE BEST OF OUR KNOWLEDGE, ENTIRELY CORRECT. HOWEVER, MAESTRO CAN NEITHER ACCEPT LIABILITY FOR ANY INACCURACIES, OR THE CONSEQUENCES THEREOF, NOR FOR ANY LIABILITY ARISING FROM THE USE OR APPLICATION OF ANY CIRCUIT, PRODUCT, OR EXAMPLE SHOWN IN THE DOCUMENT.

THE PRODUCT (HARD- AND SOFTWARE) DESCRIBED IN THIS DOCUMENTATION IS NOT AUTHORIZED FOR USE IN LIFE SUPPORT DEVICES OR SYSTEMS WITHOUT THE EXPRESS WRITTEN APPROVAL OF MAESTRO.

THIS DOCUMENT MAY PROVIDE LINKS TO OTHER WORLD WIDE WEB SITES OR RESOURCES. BECAUSE MAESTRO HAS NO CONTROL OVER SUCH SITES AND RESOURCES, MAESTRO SHALL NOT BE RESPONSIBLE FOR THE AVAILABILITY OF SUCH EXTERNAL SITES OR RESOURCES, AND DOES NOT ENDORSE AND IS NOT RESPONSIBLE OR LIABLE FOR ANY CONTENT, ADVERTISING, PRODUCTS, OR OTHER MATERIALS ON OR AVAILABLE FROM SUCH SITES OR RESOURCES. MAESTRO SHALL NOT BE RESPONSIBLE OR LIABLE, DIRECTLY OR INDIRECTLY, FOR ANY DAMAGE OR LOSS CAUSED OR ALLEGED TO BE CAUSED BY OR IN CONNECTION WITH USE OF OR RELIANCE ON ANY SUCH CONTENT, GOODS OR SERVICES AVAILABLE ON OR THROUGH ANY SUCH SITE OR RESOURCE.

MAESTRO RESERVES THE RIGHT TO CHANGE, MODIFY, OR IMPROVE THIS DOCUMENT OR THE PRODUCT DESCRIBED HEREIN, AS SEEN FIT BY MAESTRO WITHOUT FURTHER NOTICE.

## Table of Contents

<b>1 Introduction</b> .....	<b>6</b>
1.1 Feature Overview .....	6
1.2 Characteristics Overview .....	7
1.3 RoHS and Lead-Free Information .....	7
1.4 Label .....	8
1.5 Characteristics .....	9
1.5.1 GPS Characteristics .....	9
1.5.2 Mechanical Characteristics .....	9
1.6 Handling Precautions .....	9
<b>2 Ordering Information</b> .....	<b>10</b>
2.1 GPS Receivers A2200-A .....	10
2.2 Packing of the A2200-A .....	10
2.3 Additional Equipment .....	13
<b>3 Quick Start</b> .....	<b>14</b>
3.1 Minimum Configuration .....	14
3.2 Antennas .....	15
3.2.1 Passive Antennas .....	15
3.2.2 Active Antennas .....	15
3.3 Serial Port Settings .....	16
3.4 Improved TTFB .....	16
<b>4 Mechanical Outline</b> .....	<b>17</b>
4.1 Details Component Side A2200-A .....	17
4.2 Details Solder Side A2200-A .....	18
<b>5 Pin-out Information</b> .....	<b>19</b>
5.1 Layout A2200-A .....	19
5.2 Description A2200-A Signals .....	20
<b>6 Electrical Characteristics</b> .....	<b>21</b>
6.1 Operating Conditions .....	21
6.2 Absolute Maximum Ratings .....	21
6.3 DC Electrical Characteristics .....	22
<b>7 Mounting</b> .....	<b>23</b>
7.1 Proposed Footprint for Soldering .....	23
7.2 Recommended Profile for Reflow Soldering .....	23
<b>8 Use of GPS Antennas</b> .....	<b>24</b>
8.1 Connecting a GPS antenna to the GPS receiver .....	24
8.2 Antenna Connections .....	26
8.2.1 Passive Antennas .....	26
8.2.2 Active Antennas .....	26
<b>9 Quality and Reliability</b> .....	<b>27</b>
9.1 Environmental Conditions .....	27

9.2 Product Qualification .....	27
9.3 Production Test.....	27
<b>10 Applications and Hints .....</b>	<b>28</b>
10.1 Initial Module Start .....	28
10.2 Proper Shutdown .....	28
10.3 SiRFaware™ Support .....	28
10.4 Push-to-Fix Mode.....	28
10.5 Hibernate Mode.....	29
10.6 Extended Ephemeris.....	29
10.7 Antenna Status Adaptation .....	30
10.7.1 Antenna Sensor .....	30
10.7.2 Antenna Sensor with Current Limiter .....	31
10.8 VANT Pin .....	32
<b>11 Evaluation Kit EVA2200-A.....</b>	<b>33</b>
<b>12 Related Information .....</b>	<b>34</b>
12.1 Contact.....	34
12.2 Related Documents.....	34
12.3 Related Tools .....	34
<b>13 List of Figures .....</b>	<b>35</b>
<b>14 List of Tables.....</b>	<b>35</b>

## 1 Introduction

The GPS module A2200-A is Maestro's first implementation of CSR's SiRFstarIV ROM chip on GPS module. This is highly integrated GPS receivers that can be used as SMT components. A very easy implementation (power, serial, ON\_OFF, and antenna) allows receiving position, velocity and time information.

The A2200-A is a module designed for a 3.3V environment.

### 1.1 Feature Overview

The A2200-A is new module with the following outstanding features.

- Fast, responsive location experience
  - High-sensitive navigation engine with tracking down to -163dBm
  - 48 track verification channels
  - SBAS (WAAS, EGNOS, MSAS, GAGAN)
- Breakthrough micro power technology
  - Requires only 50 – 500 $\mu$ A to maintain hot start capability
- Active jammer remover
  - Removes in-band jammers up to 80dB/Hz
  - Tracks up to eight CW (continuous wave) jammers

## 1.2 Characteristics Overview

The module's most important characteristics are:

- A2200-A
  - Operable at 3.3V / 41mA @ 1 fix per second
  - UART interface at 3.3V CMOS level
  - Prepared for SPI Slave support at 3.3V CMOS
- Direct passive antenna support
- Switched antenna voltage for active antenna support
- Small form factor of 10.2 mm x 14 mm (0.40" x 0.55")
- Supported temperature range: -40°C to +85°C
- Single-sided SMT component, for reflow soldering
- Tape & reel packaging

The A2200-A receiver module is available as off-the-shelf components, 100% tested and shipped in standard tape-and-reel package.

## 1.3 RoHS and Lead-Free Information

Maestro's products marked with the lead-free symbol either on the module or the packaging comply with the "Directive 2002/95/EC of the European Parliament and the Council on the Restriction of Use of certain Hazardous Substances in Electrical and Electronic Equipment" (RoHS).



All Maestro GPS receiver modules, smart GPS antenna modules and telematics units are RoHS compliant.

### 1.4 Label

The A2200-A labels hold the following information:



General description

**Software**  
**ssss:part number**  
**tt:software release**

**Hardware**  
**rr:hardware release**

**Factory and date code**  
**GS:Factory code**  
**yy:assembly year**  
**ww:assembly week**  
**xxxxxx:serial number**

○ pin 1 mark



Example

Figure 1: A2200-A label

The label is placed on the shield of the module. The data matrix code holds the product type, part number, software release, hardware release, factory code, year & week of assembly and a 6-digit serial number.

Representing	Factory code	Product Number	Part Number	Software Release	Hardware Release	Assembly Year/Week	Serial Number
Number of digits (25)	XX 2	XXXXXXXX 6	XXXX 4	XX 2	XX 2	XXXX 4	XXXXXX 6
Example	GS	A2200A	9322	01	01	1126	000005
Meaning	GSL	Given	Given	Given	Given	Year=11 Week=26	Increment from 000001 up to 999999

Example of MID#: GSA2200A932201011126000005



## 1.5 Characteristics

The module are characterized by the following parameters.

### 1.5.1 GPS Characteristics

Channels		48, parallel tracking
Correlators		~ 400,000
Frequency		L1 (= 1,575 MHz)
Tracking Sensitivity <sup>(1)</sup>		-163 dBm
Horizontal Position Accuracy	Stand alone	< 2.5 m CEP (SA off)
Time To First Fix – TTFF (theoretical minimum values; values in real world may differ)	Obscuration recovery <sup>(2)</sup>	0.1 s
	Hot start <sup>(3)</sup>	< 1 s
	Warm <sup>(4)</sup>	< 35 s
	Cold <sup>(5)</sup>	< 35 s

Table 1: A2200-A GPS characteristics

- (1) Typical with good antenna – see also paragraph “3.2 Antennas”
- (2) The calibrated clock of the receiver has not stopped, thus it knows precise time (to the  $\mu$ s level).
- (3) The receiver has estimates of time/date/position and valid almanac and ephemeris data.
- (4) The receiver has estimates of time/date/position and recent almanac.
- (5) The receiver has no estimate of time/date/position, and no recent almanac.

Note: Performance (sensitivity and TTFF) might slightly decrease below -30°C.

### 1.5.2 Mechanical Characteristics

A2200-A Mechanical dimensions	Length	14±0.20 mm, 0.55±0.008”
	Width	10.2±0.20 mm, 0.40±0.008”
	Height	2.5 mm, 0.1” (Max)
A2200-A Weight		0.6 g, 0.022 oz

Table 2: A2200-A dimensions and weight

## 1.6 Handling Precautions

The GPS receiver module A2200-A is sensitive to electrostatic discharge (ESD). Please handle with appropriate care.

## 2 Ordering Information

### 2.1 GPS Receivers A2200-A

The order number is built as follows:

- **A2200-Axxxx**

A2200-A is the model name. The “xxxx” refers to the current part number on the module.

### 2.2 Packing of the A2200-A

The A2200-A GPS module come in a tape and reel package suitable for pick and place machines.

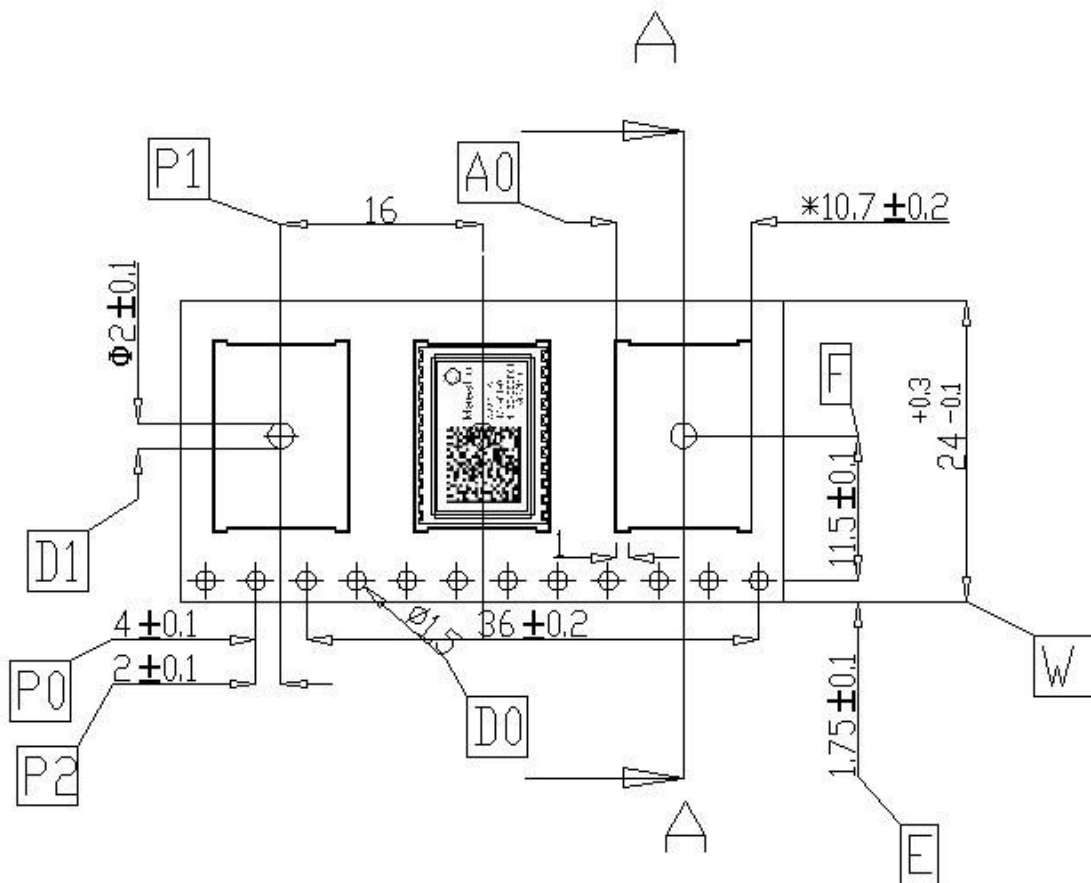

Figure 2: A2200-A tape specifications (1)

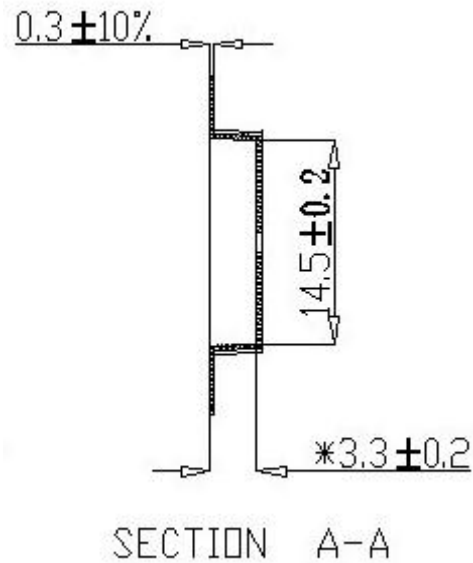

Figure 3: A2200-A tape specifications (2)

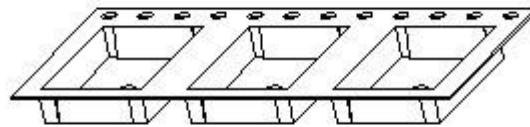

Figure 4: A2200-A tape specifications (3)

One complete reel holds 1300 pcs A2200-A modules.

There are 2 kinds of packaging for shipment:

A: One box holds 1 reel

Reel diameter: 33 cm

Inner box dimensions: 36(W) x 36(L) x 4.5 (H) cm

Box dimensions: 38.8 (W) x 38.8 (L) x 5.7 (H) cm

Gross weight: 2.58 Kg

Net weight: 0.78 Kg

B. One box holds 3 reels

Reel diameter: 33 cm

Inner box dimensions: 36 (W) x 36 (L) x 4.5 (H) cm  
Outer box dimensions: 38 (W) x 38 (L) x 16 (H) cm  
Gross weight: 4.92 Kg  
Net weight: 2.34 Kg

## 2.3 Additional Equipment

EVA2200-A	Evaluation Kit (including one module A2200-A)
-----------	---

Table 3: Additional equipment

A detailed description of the EVA2200-A Evaluation Kit can be found in the appropriate manual.

### 3 Quick Start

In order to allow an easy and quick start with the A2200-A module, this chapter provides a short overview on the important steps to be taken to receive NMEA messages with position information on a serial port (UART).

**NOTE 1:** The A2200-A needs an external pull-up resistor to be configured for UART operation. Please consider the pull-up resistor in your design or pull the GPIO up right after reset by other means.

**NOTE 2:** The ON\_OFF input of the A2200-A needs to be connected to a push-pull output of a microprocessor. For a wake-up, including the initial one after power on, a LOW-HIGH transmission is mandatory.

**NOTE 3:** It is recommended to connect the nRST pin of the A2200-A to an open collector / open drain output of a microprocessor!

#### 3.1 Minimum Configuration

The following picture shows the minimum configuration for NMEA or binary outputs received and commands sent via an RS232 interface based on the GPS module A2200-A using a passive antenna.

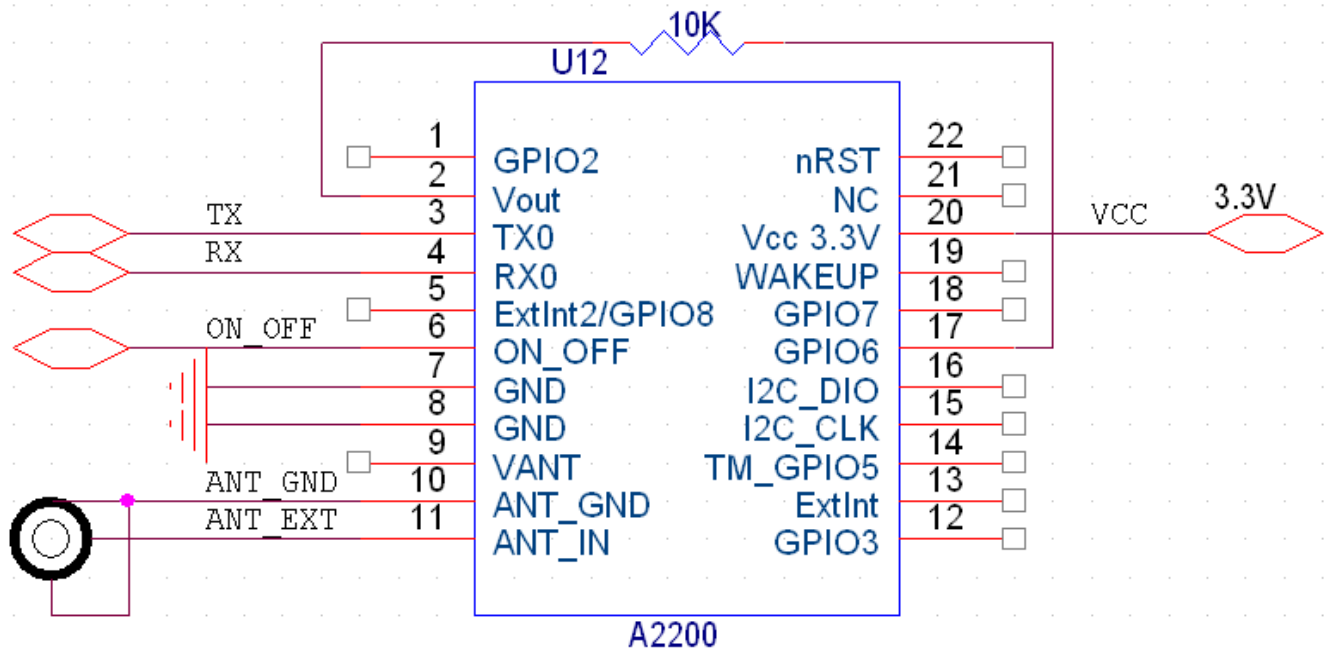

Figure 5: Minimum configuration A2200-A

**NOTE:** It is recommended to supply Vcc continuously! Use SiRFaware™ or other low power modes to reduce power consumption of the module while no position information is required.

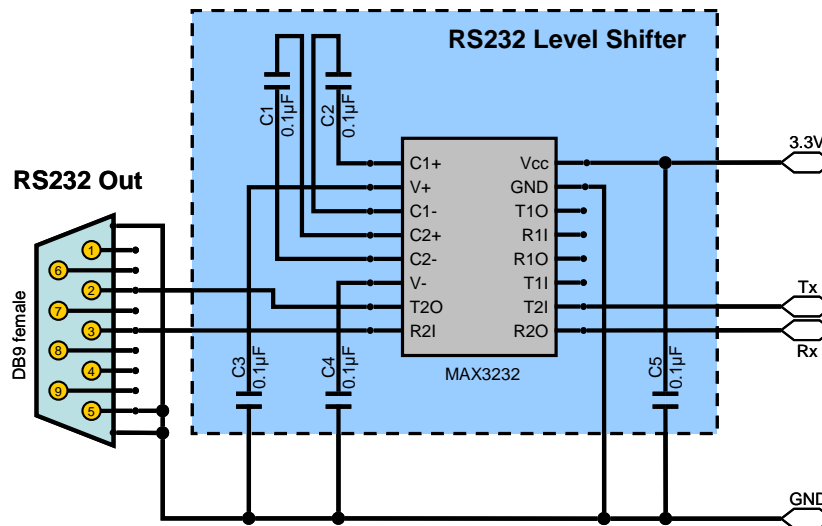

Figure 6: RS232 level shifter

Remarks:

- Place C1 to C5 (here: 0.1µF) close to MAX3232. For capacity values see datasheet of actual component used.
- Use 3.3V level shifter (MAX3232 or equivalent).
- External antenna input impedance is 50 Ω. Match as close as possible.

## 3.2 Antennas

Generally, the quality of the GPS antenna chosen (passive or active) is of paramount importance for the overall sensitivity of the GPS system. Losses through a bad antenna, long cables or tracks or a bad antenna position can't be compensated afterwards!

### 3.2.1 Passive Antennas

The A2200-A supports passive antennas via an integrated LNA directly.

### 3.2.2 Active Antennas

The A2200-A also supports active antennas directly, i.e. by offering an antenna voltage feed pin (VANT – pin 9). It is recommended to use an active antenna with a supply voltage of 3 to 5 VDC and a maximum current draw of 50 mA. The antenna should have a gain  $\geq 15$ dB but the total gain (antenna gain minus cable loss at the

antenna input of the module) should not exceed 30 dB. The noise figure should be  $\leq$  1.5dB.

### 3.3 Serial Port Settings

In UART operation (defined by the external pull-up resistor as outlined in Minimum Configuration) the default settings are:

- NMEA, 4800 baud, 8 data bits, no parity, 1 stop bit, no flow control

### 3.4 Improved TTFF

In order to improve the TTFF (Time To First Fix), it is recommended to keep Vcc supplied at all times. This will allow taking advantage of sophisticated low power mode features of the SiRFstarIV ROM chip set.



## 4 Mechanical Outline

### 4.1 Details Component Side A2200-A

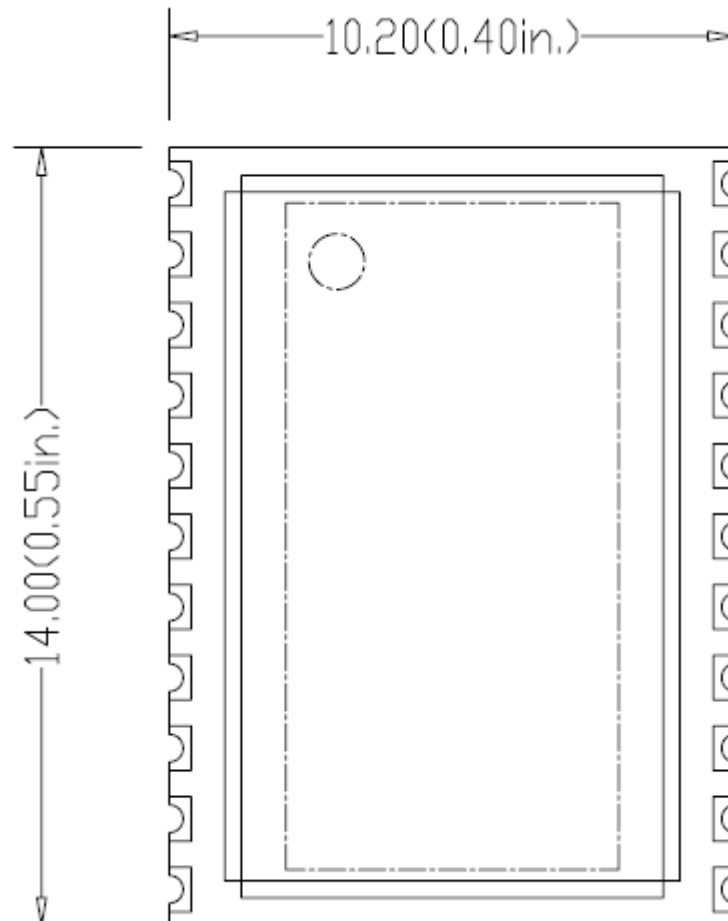

All dimensions in [mm, (inch)]

Figure 7: Mechanical outline component side A2200-A

## 4.2 Details Solder Side A2200-A

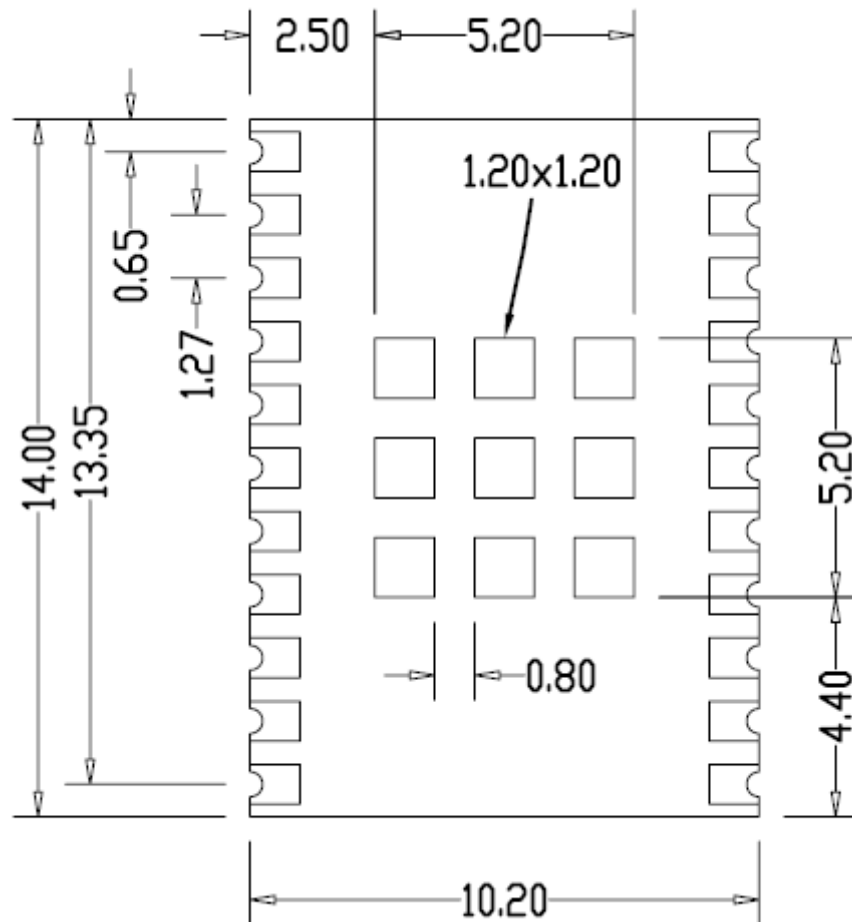

Solder pad size (outer pads): 1.0 x 0.8  
 Solder pad size (inner pads): 1.2 x 1.2  
 All dimensions in [mm]

Figure 8: Mechanical outline solder side A2200-A

## 5 Pin-out Information

### 5.1 Layout A2200-A

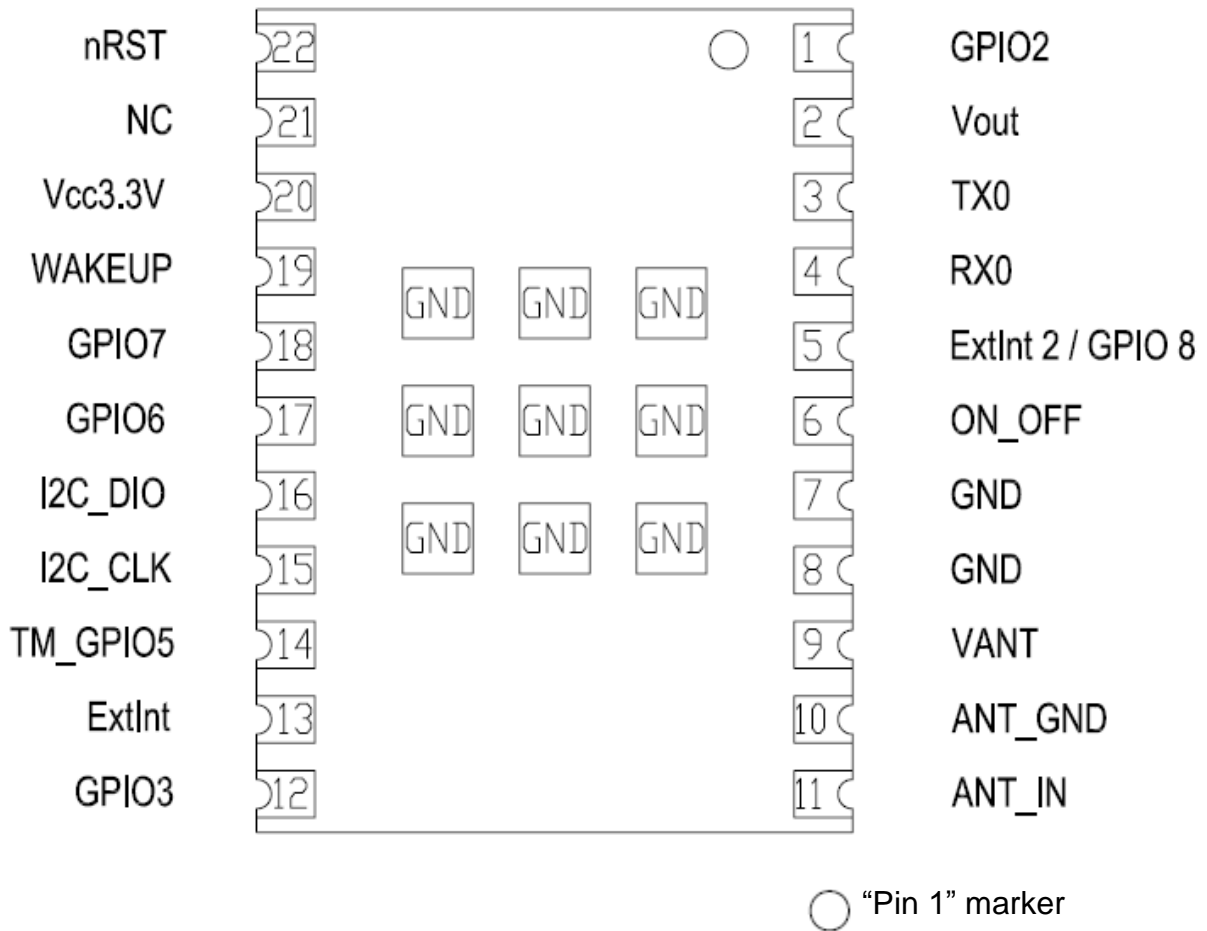

Figure 9: Pin-out information (bottom view) A2200-A

Center Ground pins are for shock / vibration resistance purpose.

## 5.2 Description A2200-A Signals

Pin	Symbol	Function	Description
1	GPIO2	Input/Output	Leave open
2	Vout	Voltage output	Permanent 1.8V voltage output for up to 20mA current max.
3	TX0 SPI DO	Output	Serial output 0, NMEA out if configured for UART SPI data out pin when module works in SPI mode
4	RX0 SPI DI	Input	Serial input 0, NMEA in if configured for UART SPI data in pin when module works in SPI mode
5	ExtInt 2/GPIO8	Input	Interrupt input 2 (If ExtInt 2 is not going to be used, it is recommended that this pin be tied directly to ground. Otherwise, a 100K pull-down resistor to ground should be connected to the ExtInt 2 pin.)
6	ON_OFF	Input	Connect to push-pull output! This is mandatory! - Set to LOW by default - Toggle to HIGH and back to LOW - for first start-up after power on - to request a fix in SiRFaware™ or PTF mode - to go into or wake up out of hibernate mode
7	GND	Power Supply	Ground (power supply)
8	GND	Power Supply	Ground (power supply)
9	VANT	Antenna Supply Voltage Input	Power supply input for external active antenna – provide according voltage (up to 5.0 VDC) – switched internally
10	ANT_GND	RF GND	Antenna Ground
11	ANT_IN	Antenna Input	Antenna signal / Z=50 Ohm (antenna input) – must not exceed 30dB gain including cable loss
12	GPIO3	Input/Output	Leave open
13	ExtInt	Input/Output	Interrupt input for MEMS interface
14	TM_GPIO5	Output	Time Mark – 1PPS signal
15	I2C CLK	Input	I2C clock input for MEMS interface
16	I2C DIO	Input/Output	I2C I/O for MEMS interface
17	GPIO6 SPI CLK	Input	Configuration pin to run in UART mode (10k pull-up to 1.8V, e.g. to Vout, pin 2) SPI clock pin when module works in SPI mode
18	GPIO7 SPI CS	Input	Unused configuration pin – reserved for future use, leave open SPI chip select pin when module works in SPI mode
19	WAKEUP	Output	Status of digital section, Push-Pull output Low = OFF, KA (Keep Alive)-only, Hibernate, or Standby mode High = ON, operational mode
20	Vcc	Power Supply	3.0 – 3.6 VDC (power supply)
21	NC	None	Leave open
22	nRST	Input	Reset input (open / HIGH – no reset, LOW - reset) Connect to open collector / open drain output!

Table 4: Pin description A2200-A

## 6 Electrical Characteristics

### 6.1 Operating Conditions

Pin	Description	Min	Typical	Max
3	Vcc	3.0V	3.3V	3.6V
	Full power mode (Searching) Peak Current (1)		69mA	
	Full power mode (Searching) Average Current (2)		52 mA	
	Full power mode (Tracking) Average Current (3)		41 mA	
	TricklePower™ Mode		12.7 mA	
	Push-to-Fix Mode		325 uA	
	Micro Power Mode ( SiRFaware™)		35 uA	
	Hibernate Status		25 uA	

Table 5: A2200-A electrical characteristics

- (1) Peak searching current is characterized by millisecond bursts above average searching current
- (2) Average searching current is typically only the first two seconds of TTFF
- (3) Tracking current typically includes tracking and the post searching portion of TTFF

### 6.2 Absolute Maximum Ratings

Symbol	Parameter	Min	Max	Unit
Vcc	A2200-A Power supply	-0.3	+3.6	V
Vin	Voltage to I/O pins	-0.3	+3.6	V
Iov	Input current on I/O pins	-10	10	mA
Itdv	Absolute sum of all input currents during overload condition		200	mA
Tst	Storage temperature	-40	85	°C
Vant	Antenna supply voltage	0	5.5	V
Iant	Antenna supply current	0	50	mA

Table 6: Absolute maximum ratings

Stresses beyond those listed under “Absolute Maximum Ratings” may cause permanent damage to the device. This is a stress rating only. Functional operation of the device at these or any other conditions beyond those indicated in the operational sections of this specification is not implied. Exposure to absolute maximum rating conditions for extended periods may affect device reliability.

### 6.3 DC Electrical Characteristics

Symbol	Parameter	Min	Max	Unit
TX0, WAKEUP	Voh @ 4mA	2.6	Vcc	V
	Vol @ 4mA		0.45	V
RX0	Vih	2.0	Vcc	V
	Vil		0.8	V
nRST	for safe reset		0.2	V
ON_OFF	Vih	1.35	Vcc	V
	Vil	-0.3	0.45	V
BOOTSEL	Vih	1.35	2.2	V

Table 7: DC electrical characteristic A2200-A

## 7 Mounting

This chapter describes the suggested mounting process for the A2200-A receiver module. In a RoHS compliant product with a RoHS compliant process it is recommended to use chemical tin as the counter-part to the module's pins. This will guarantee highest resistance against shocks.

### 7.1 Proposed Footprint for Soldering

Following soldering footprint parameters are recommended:

- Copper and solder paste footprint are identical
- Pad-shape / -size, inner pads: 1.2 mm x 1.2 mm
- Pad-shape / -size, outer pads: 1.0 mm x 0.8 mm
- Stencil thickness of 120 – 150 µm

### 7.2 Recommended Profile for Reflow Soldering

Typical values for reflow soldering of the module in convection or IR/convection ovens are as follows (according to IPC/JEDEC J-STD-020D):

Parameter	Value
Peak temperature (RoHS compliant process)	245°C
Average ramp up rate to peak (217°C to Peak)	3°C / second max.
Preheat temperature	min=150°C; max=200°C
Ramp up time from min. to max. preheat temperature	60 ... 120 seconds
Temperature maintained above 217°C	60 ... 150 seconds
Time within 5°C of actual peak temperature	30 seconds
Ramp down rate	6°C / second max.
Time 25°C to peak temperature	8 minutes max.

Table 8: Reflow soldering profile A2200-A

The solder pads hold solder of a thickness of about 150 µm for improved solder process results.

As results of soldering may vary among different soldering systems and types of solder and depend on additional factors like density and types of components on board, the values above should be considered as a starting point for further optimization.

## 8 Use of GPS Antennas

### 8.1 Connecting a GPS antenna to the GPS receiver

The ANT pin is used to connect a GPS antenna to the receiver. The design of the antenna connection has to be done strictly according to RF design rules. A  $50\ \Omega$  PCB strip line is required. The following drawings shall explain the guidelines. A major rule is to keep the strip line as short as possible. Additionally, antenna ground (ANT\_GND) should be routed to the ground plane of the PCB (the ground plane is on a lower PCB layer) by vias as demonstrated in the drawing.

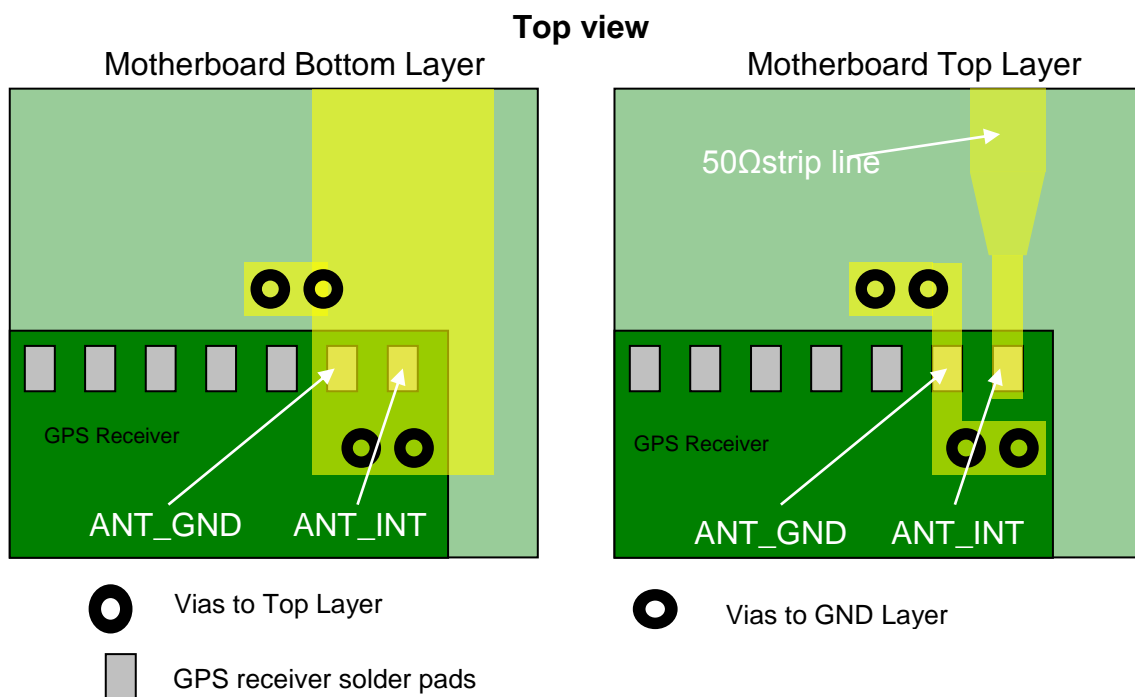

Figure 10: Antenna connector strip line A2200-A

In order to achieve the impedance of  $50\ \Omega$ , the width of the strip line needs to be calculated. It depends on the thickness or height of the PCB layer (both parameters are shown in following drawing). For the calculation, it is assumed that the PCB material is FR4.

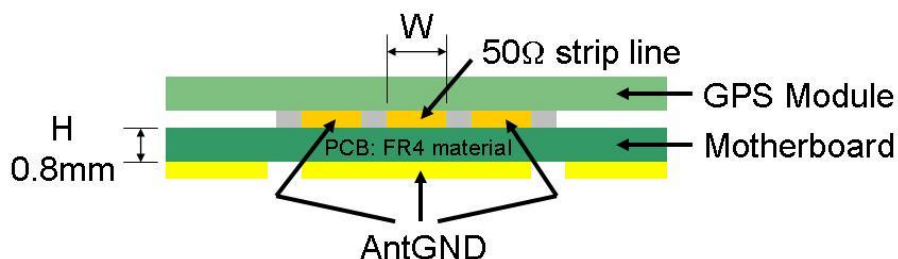

Figure 11: Strip line parameters A2200-A



In this case, the width should be about 1.8 times the height of the PCB:

$$W = 1.8 \times H$$

In the example, one would get a width of  $W = 1.8 \times 0.8 \text{ mm} = 1.44 \text{ mm}$ .

## 8.2 Antenna Connections

### 8.2.1 Passive Antennas

A passive antenna connected to ANT\_IN input (pin 11) should be placed as close as possible to the GPS receiver. The signal power lost by the antenna cable or lost by the strip line on the PCB can not be recovered by the LNA (Low Noise Amplifier) integrated in the GPS receiver.

A suitable Ground-Plane design should be considered depending on the antenna type connected to ANT\_IN input (pin 11).

### 8.2.2 Active Antennas

General GPS active antenna specification:

Limitations:

- Supply voltage (voltage fed into VANT pin) 5V (max.)
- Supply current 50mA (max.)

Recommendations:

- Gain  $\geq 15$ dB (should not exceed 20 dB including cable loss)
- Noise figure  $\leq 1.5$ dB

The recommendations apply to the majority of active antennas that can be found in the market. Anyhow, the quality of the GPS antenna chosen is of paramount importance for the overall sensitivity of the GPS system.

The system design needs to reflect the supply voltage of the antenna. If the supply voltage is equal to  $V_{cc}$ ,  $V_{cc}$  can be connected to VANT. If the antenna requires a different supply voltage, the antenna bias can be provided through the VANT pin.

VANT is switched by the module, so current is only drawn when required.

## 9 Quality and Reliability

### 9.1 Environmental Conditions

Operating temperature	-40 ... +85°C
Operating humidity	Max. 85% r. H., non-condensing, at 85°C
MSL JEDEC (Moisture Sensitivity Level)	3
Storage	6 months in original package.

Table 6: Environmental conditions

### 9.2 Product Qualification

Prior to product qualification the GPS receiver is preconditioned according to EIA/JEDEC standard JESD22-A113-B / Level 3.

Basic qualification tests:

- MSL Classification according to J-STD-020C (MSL3 @ 245°C)
- MSL Rework Compatibility according to J-STD-020C
- Temperature Cycling –40°C ... +85°C
- Temperature Humidity Bias 70°C / 85% RH
- Low / High Temperature Operating –40°C / +85°C
- High Temperature Operating Life +85°C
- Vibration Variable Frequency
- Mechanical Shock

Please contact Maestro for detailed information.

### 9.3 Production Test

Each module is electrically tested prior to packing and shipping to ensure state of the art GPS receiver performance and accuracy.

## 10 Applications and Hints

### 10.1 Initial Module Start

After initially applying power to the module, it is necessary to start the internal firmware by toggling the ON\_OFF pin. Toggling is done by pulling the signal to HIGH for about 100ms. This first toggling can be done after a LOW – HIGH transmission is detected at the WAKEUP pin or by simply waiting for 1s after power-up. In case of configuration for UART mode, messages should be transmitted afterwards. If no messages should appear, a new toggling should be applied.

### 10.2 Proper Shutdown

The A2200-A module requires an orderly shutdown process to properly stop internal operation and complete any writes of critical data to BBRAM or EEPROM data area. Abrupt removal or drop of main power while the system is running has risks ranging from minor impact on TTFB to fatal, permanent corruption of EEPROM code area on the module.

A controlled and orderly shutdown while the A2200-A is running in full power mode can be initiated by

- A 100ms pulse on the ON\_OFF pin, or
- According messages either in NMEA or OSP mode.

The shutdown is completed after maximum 1s. Therefore the module should be supplied with voltage for that time after the shutdown sequence was initiated.

### 10.3 SiRFaware™ Support

SiRFaware™ is a low-power operating mode that seeks to maintain low uncertainty in position, time, and frequency, and to maintain valid current Ephemeris using either data collected from satellites in view or Extended Ephemeris methods.

The SiRFaware™ mode is entered using the One Socket Protocol, an extension of the SiRF Binary Protocol. Please refer to the appropriate manual. In order to request a fix and to exit SiRFaware™ it is necessary to toggle the ON\_OFF pin. Toggling is done by pulling the signal to HIGH for about 100ms.

### 10.4 Push-to-Fix Mode

Push-to-Fix mode is designed for the application that requires infrequent position reporting. The receiver generally stays in a low-power mode, up to 2 hours, but wakes up periodically to refresh position, time, ephemeris data and RTC calibration.

The push-to-fix mode is initialized and entered using the SiRF Binary Protocol. Please refer to the appropriate manual, paying particular attention to the paragraph titled “Set TricklePower Parameters”. In order to request a fix outside the specified

duty cycles, it is necessary to toggle the ON\_OFF pin. Toggling is done by pulling the signal to HIGH for about 100ms.

### 10.5 Hibernate Mode

In order to enter Hibernate Mode it is necessary to send a shutdown command or to toggle to ON\_OFF pin by pulling the signal to HIGH for about 100ms. Starting with firmware version 4.0.1 the according command is supported in NMEA and SiRF Binary mode. After a short delay the module will switch into hibernate mode. The RTC will keep on running and SRAM is backed with the typical current of 20  $\mu$ A drawn from Vcc. To wake the module up again, toggling the ON\_OFF pin is necessary (100ms pulse width).

### 10.6 Extended Ephemeris

The receiver is capable of supporting two versions of using Extended Ephemeris (EE) data. The first one is the version, where the EE data are calculated on a server, are transmitted to device incorporating the receiver, and are then loaded into the receiver. These data can be valid for up to seven days.

The second version is the internal extrapolation of available “natural” Ephemeris data. This is done automatically and no external support is required. The internally calculated EE data are valid for up to 3 days.

The receiver firmware will define which set of EE data to use or will neglect those in case “natural” data are available (need add an external EEPROM part). Both versions of EE data will help to further lower power consumption in SiRFaware™ mode.

## 10.7 Antenna Status Adaptation

This chapter shall give assistance in designing a circuit for detecting if an active antenna is connected to the module. The information about the antenna status can be derived from the ANTSTAT signal generated by this circuit. The examples use values for components that roughly result in the following ANTSTAT output:

- Logic low when:  $I_{ant} < 9\text{mA}$
- Logic high when:  $9\text{mA} > I_{ant} < 16\text{mA}$
- Logic low when:  $I_{ant} > 16\text{mA}$

### 10.7.1 Antenna Sensor

The following circuit is a proposal on how you can feed an antenna with 3.3V and provide an output for the ANTSTAT pin. The value of the components may need an adaptation in the final application. For example, the input current of the chosen comparator goes into that equation. The thresholds defined in this circuit are quite close to the ones described above. Their value is determined by resistors R4, R5, and R3.

We strongly recommend simulating and testing the GPS receiver integrated in your product design before implementing the finalized product in the appropriate market application.

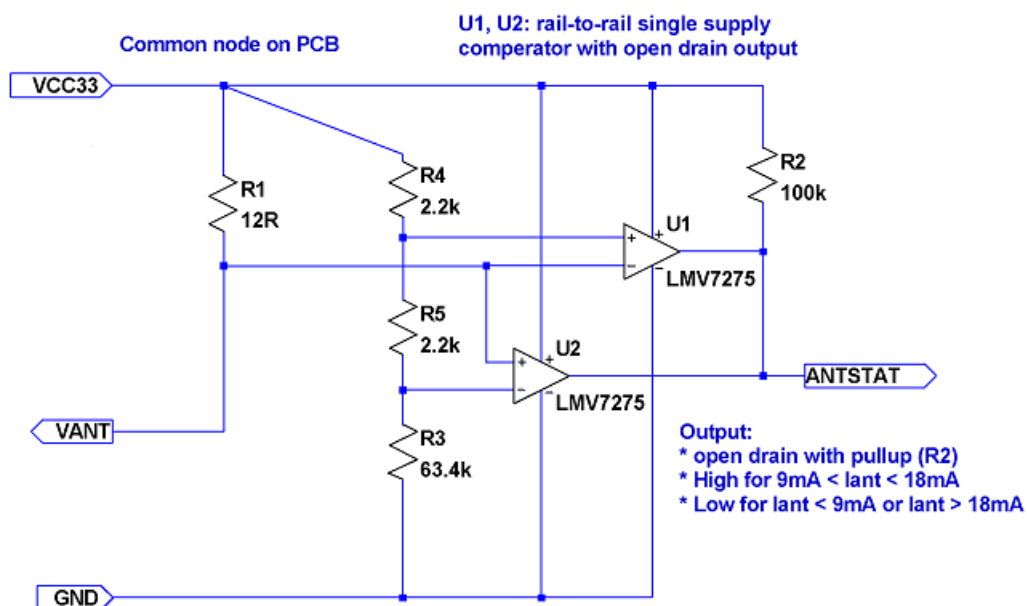

Figure 12: Application note: Antenna sensor adaptation

### 10.7.2 Antenna Sensor with Current Limiter

This proposal is similar to the first one, but includes a current limiter. Comments and notes as above apply.

We strongly recommend simulating and testing the GPS receiver integrated in your product design before implementing the finalized product in the appropriate market application. In any case it is the responsibility of the designer to test and verify the implementation.

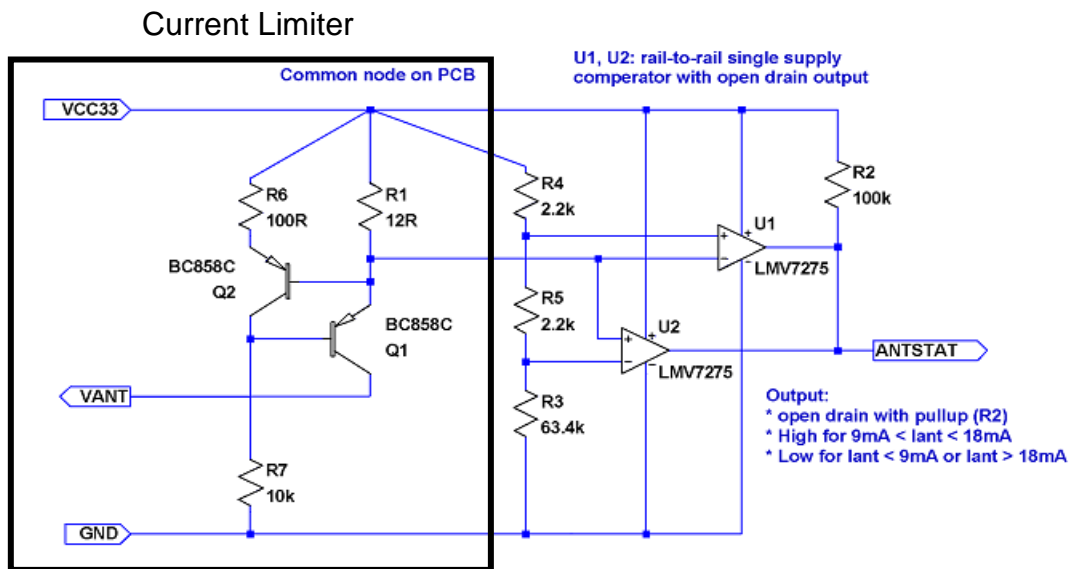

Figure 13: Application note: Antenna sensor adaptation with current limiter

## 10.8 VANT Pin

The VANT pin is an input pin.

The supply voltage for an active GPS antenna on the ANT input has to be fed into the Vant pin. The easiest way to do that is to connect Vcc to VANT. The maximum current is 50 mA.

**Note:** Shortcut between ANT and GND may damage the A2200-A GPS receiver module. This should be avoided by using an antenna current limiter.

The circuit (chapter “10.7.2 Antenna Sensor with Current Limiter”) works for Vcc from 3V to 5V. The antenna current will be limited to 50 mA approximately.

If other transistors are used, other resistor values may be necessary as well. We strongly recommend simulating and testing your realized version before using it.



## 11 Evaluation Kit EVA2200-A

For demonstration and easy evaluation of GPS performance Maestro offers an evaluation kit (including one GPS A2200-A module). It contains a USB interface with according drivers to connect easily to a PC. The USB interface is an extension of the serial port 0, therefore sending NMEA sentences or binary information and accepting commands. At the same time it provides power to the module. Accompanied by both an active and passive antenna it offers a ready-to-go set.

For the development of new software and applications the Evaluation Kit also provides NMEA and binary messages on CMOS level via a terminal plug.

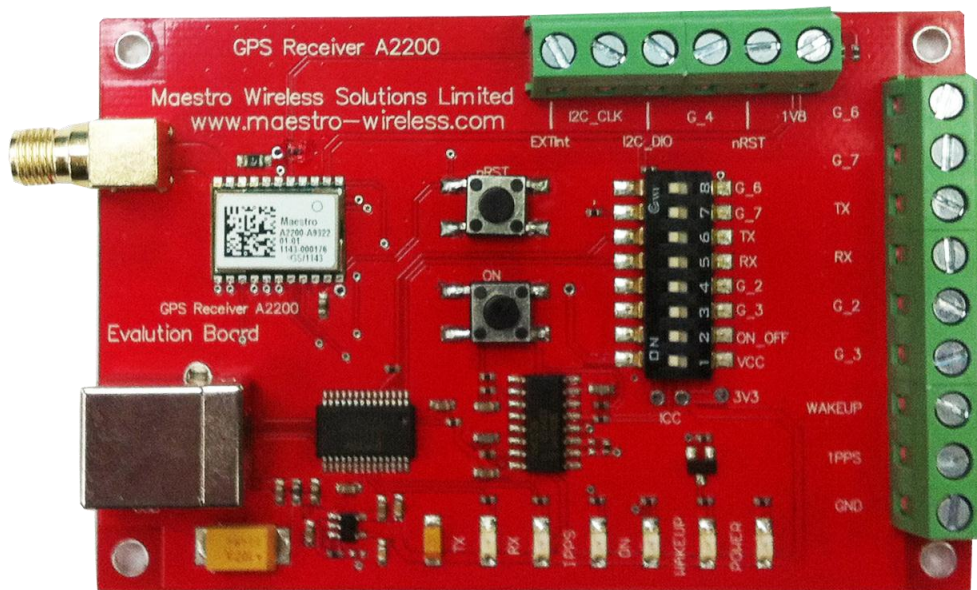

Figure 14: Evaluation kit EVA2200-A

For further information please contact Maestro.

## 12 Related Information

### 12.1 Contact

This manual is created with due diligence. We hope that it will be helpful to the user to get the most out of the GPS module.

Inputs regarding errors or mistaken verbalizations and comments or proposals to Maestro, Hongkong, for further improvements are highly appreciated.

#### **Maestro Wireless Solutions Limited**

Address: Unit 3603-09, 36/F., 118 Connaught Road West, HK

Main Line: (852) 28690688

Fax: (852) 25254701

[support-gps@maestro-wireless.com](mailto:support-gps@maestro-wireless.com)

[www.maestro-wireless.com](http://www.maestro-wireless.com)

### 12.2 Related Documents

- GPS Evaluation Kit EVA2200-A (Maestro)
- GSD4e NMEA Manual (SiRF)
- GSD4e OSP Manual (SiRF)

### 12.3 Related Tools

- GPS Cockpit (Maestro)
- SiRFLive (SiRF)

## 13 List of Figures

Figure 1: A2200-A label .....	8
Figure 2: A2200-A tape specifications (1) .....	10
Figure 3: A2200-A tape specifications (2) .....	11
Figure 4: A2200-A tape specifications (3) .....	11
Figure 5: Minimum configuration A2200-A .....	14
Figure 6: RS232 level shifter .....	15
Figure 7: Mechanical outline component side A2200-A .....	17
Figure 8: Mechanical outline solder side A2200-A .....	18
Figure 9: Pin-out information (bottom view) A2200-A .....	19
Figure 10: Antenna connector strip line A2200-A.....	24
Figure 11: Strip line parameters A2200-A.....	24
Figure 12: Application note: Antenna sensor adaptation.....	30
Figure 13: Application note: Antenna sensor adaptation with current limiter.....	31
Figure 14: Evaluation kit EVA2200-A.....	33

## 14 List of Tables

Table 1: A2200-A GPS characteristics.....	9
Table 2: A2200-A dimensions and weight.....	9
Table 3: Additional equipment.....	13
Table 4: Pin description A2200-A.....	20
Table 5: A2200-A electrical characteristics .....	21
Table 6: Absolute maximum ratings .....	21
Table 7: DC electrical characteristic A2200-A.....	22
Table 8: Reflow soldering profile A2200-A .....	23



**Стандарт  
Электрон  
Связь**

Мы молодая и активно развивающаяся компания в области поставок электронных компонентов. Мы поставляем электронные компоненты отечественного и импортного производства напрямую от производителей и с крупнейших складов мира.

Благодаря сотрудничеству с мировыми поставщиками мы осуществляем комплексные и плановые поставки широчайшего спектра электронных компонентов.

Собственная эффективная логистика и склад в обеспечивает надежную поставку продукции в точно указанные сроки по всей России.

Мы осуществляем техническую поддержку нашим клиентам и предпродажную проверку качества продукции. На все поставляемые продукты мы предоставляем гарантию .

Осуществляем поставки продукции под контролем ВП МО РФ на предприятия военно-промышленного комплекса России , а также работаем в рамках 275 ФЗ с открытием отдельных счетов в уполномоченном банке. Система менеджмента качества компании соответствует требованиям ГОСТ ISO 9001.

Минимальные сроки поставки, гибкие цены, неограниченный ассортимент и индивидуальный подход к клиентам являются основой для выстраивания долгосрочного и эффективного сотрудничества с предприятиями радиоэлектронной промышленности, предприятиями ВПК и научно-исследовательскими институтами России.

С нами вы становитесь еще успешнее!

**Наши контакты:**

**Телефон:** +7 812 627 14 35

**Электронная почта:** [sales@st-electron.ru](mailto:sales@st-electron.ru)

**Адрес:** 198099, Санкт-Петербург,  
Промышленная ул, дом № 19, литера Н,  
помещение 100-Н Офис 331