



MAX9060–MAX9065 Evaluation Kits

General Description

The MAX9060–MAX9065 evaluation kits (EV kits) are fully assembled and tested PCBs that evaluate the MAX9060–MAX9064 single comparators and the MAX9065 window detector comparator. The MAX9060/MAX9061 EV kits require an external reference (REF) voltage between 0.9V and 5.5V, while the MAX9062/MAX9063/MAX9064 come with an internal reference voltage of 0.2V. The MAX9065 comes preprogrammed with trip points at 3V and 4.2V. The MAX9062–MAX9065 operate from a VCC supply between 1V to 5.5V. All EV kits have a common -0.3V to +5.5V input voltage (IN) range.

The MAX9060–MAX9065 EV kits are configured to evaluate both the 4-bump UCSP™ (installed) and an optional 5-pin SOT23 (to do so, request a free MAX9060–MAX9065 SOT23 IC sample from the factory when ordering the EV kits).

Component List

DESIGNATION	QTY	DESCRIPTION
C1, C2	2	0.1 μ F \pm 10%, 25V X7R, ceramic capacitors (0603) Murata GRM188R71E104K TDK C1608X7R1E104K
JU1	1	3-pin header
R1, R2	2	100k Ω \pm 5% resistors* (0603)
U1	1	See the <i>EV Kit-Specific Component List</i>
U2	0	Not installed, single comparators (5 SOT23) Maxim MAX9060–MAX9065
—	1	PCB: MAX9060/1/2/3/4/5 Evaluation Kit+

*R1 and R2 are not installed on the MAX9064/MAX9065.

Features

- ◆ -0.3V to +5.5V Input Voltage Range
- ◆ 0.9V to 5.5V External Reference Range (MAX9060/MAX9061)
- ◆ 1V to 5.5V VCC Range (MAX9062–MAX9065)
- ◆ 0.2V Internal Reference Voltage (MAX9062/MAX9063/MAX9064)
- ◆ 3V and 4.2V Trip Points (MAX9065)
- ◆ Evaluates 4-Bump UCSP and Optional 5-Pin SOT23 Packages
- ◆ Lead-Free and RoHS Compliant
- ◆ Fully Assembled and Tested

Ordering Information

PART	TYPE
MAX9060EVKIT+	EV Kit
MAX9061EVKIT+	EV Kit
MAX9062EVKIT+	EV Kit
MAX9063EVKIT+	EV Kit
MAX9064EVKIT+	EV Kit
MAX9065EVKIT+	EV Kit

+Denotes lead-free and RoHS compliant.

Evaluate: MAX9060–MAX9065

UCSP is a trademark of Maxim Integrated Products, Inc.



MAX9060–MAX9065 Evaluation Kits

EV Kit-Specific Component List

PART	DESIGNATION	DESCRIPTION
MAX9060EVKIT+	U1	External reference, noninverting single comparator (4 UCSP) Maxim MAX9060EBS+ (Top Mark: AFX)
MAX9061EVKIT+		External reference, inverting single comparator (4 UCSP) Maxim MAX9061EBS+ (Top Mark: AFY)
MAX9062EVKIT+		Internal reference, noninverting single comparator (4 UCSP) Maxim MAX9062EBS+ (Top Mark: AFZ)
MAX9063EVKIT+		Internal reference, inverting single comparator (4 UCSP) Maxim MAX9063EBS+ (Top Mark: AGA)
MAX9064EVKIT+		Internal reference push-pull noninverting single comparator (4 UCSP) Maxim MAX9064EBS+ (Top Mark: AGB)
MAX9065EVKIT+		Single window comparator (4 UCSP) Maxim MAX9065EBS+ (Top Mark: AGC)

Component Suppliers

SUPPLIER	PHONE	WEBSITE
Murata Electronics North America, Inc.	770-436-1300	www.murata-northamerica.com
TDK Corp.	847-803-6100	www.component.tdk.com

Note: Indicate that you are using the MAX9060, MAX9061, MAX9062, MAX9063, MAX9064, or MAX9065 when contacting these component suppliers.

MAX9060–MAX9065 Evaluation Kits

Quick Reference

Recommended Equipment

Before beginning, the following equipment is needed:

- Two +5V DC power supplies (VCC/REF, IN)
- Optional third +5V DC power supply (EXT for MAX9060–MAX9063 only)
- One digital multimeter (DMM)

Procedure

The MAX9060–MAX9065 EV kits are fully assembled and tested. Follow the steps below to verify board operation. **Caution: Do not turn on the power supply until all connections are completed.**

- 1) Verify that a shunt is installed on pins 1-2 of jumper JU1.
- 2) Connect all power-supply ground terminals to a GND pad.
- 3) Connect the positive terminal of a DC power supply to the VCC/REF pad.
- 4) Connect the positive terminal of a DC power supply to the IN pad.
- 5) Connect the positive terminal of a DC power supply to the EXT pad (MAX9060–MAX9063 only).
- 6) Turn on the VCC/REF power supply and set it to the desired level.
- 7) Turn on the IN power supply and set it to the desired level.
- 8) Turn on the EXT power supply and set it to the desired level (MAX9060–MAX9063 only).
- 9) Monitor the output using a DMM at the OUT1 pad, and study its response to varying voltages at IN.

Detailed Description of Hardware

The MAX9060–MAX9065 EV kits are fully assembled and tested PCBs that evaluate the MAX9060–MAX9064 single comparators and the MAX9065 window detector comparator. The MAX9060/MAX9061 EV kits require an external reference (REF) voltage between 0.9V and 5.5V, while the MAX9062/MAX9063/MAX9064 EV kits have an internal reference voltage of 0.2V. The MAX9065 comes preprogrammed with trip points at 3V and 4.2V. The MAX9062–MAX9065 require VCC between 1V to 5.5V to operate. All EV kits have a common -0.3 to +5.5V input voltage (IN) range.

VCC/REF Supply Selection

The VCC/REF pad is used to supply either a 0.9V to 5.5V reference voltage (MAX9060/MAX9061) or a 1V to 5.5V VCC supply (MAX9062–MAX9065) to the IC.

The MAX9060–MAX9065 EV kits can evaluate both 4-bump UCSP (U1) and 5-pin SOT23 (U2) packages. The EV kits offer the option to power up U1 or U2 separately though configuration of jumper JU1. See Table 1 for power-up options.

Table 1. Jumper JU1 Functions

SHUNT POSITION	VCC/REF PAD
1-2*	Powers U1 (UCSP) sub circuit
2-3	Powers optional U2 (SOT23) sub circuit

*Default position.

EXT Pad

The EXT pad on the EV kits can be used as an external source to pull the outputs high through resistors R1 or R2 when open-drain versions of the parts are used.

MAX9060–MAX9065 Evaluation Kits

Evaluate: MAX9060–MAX9065

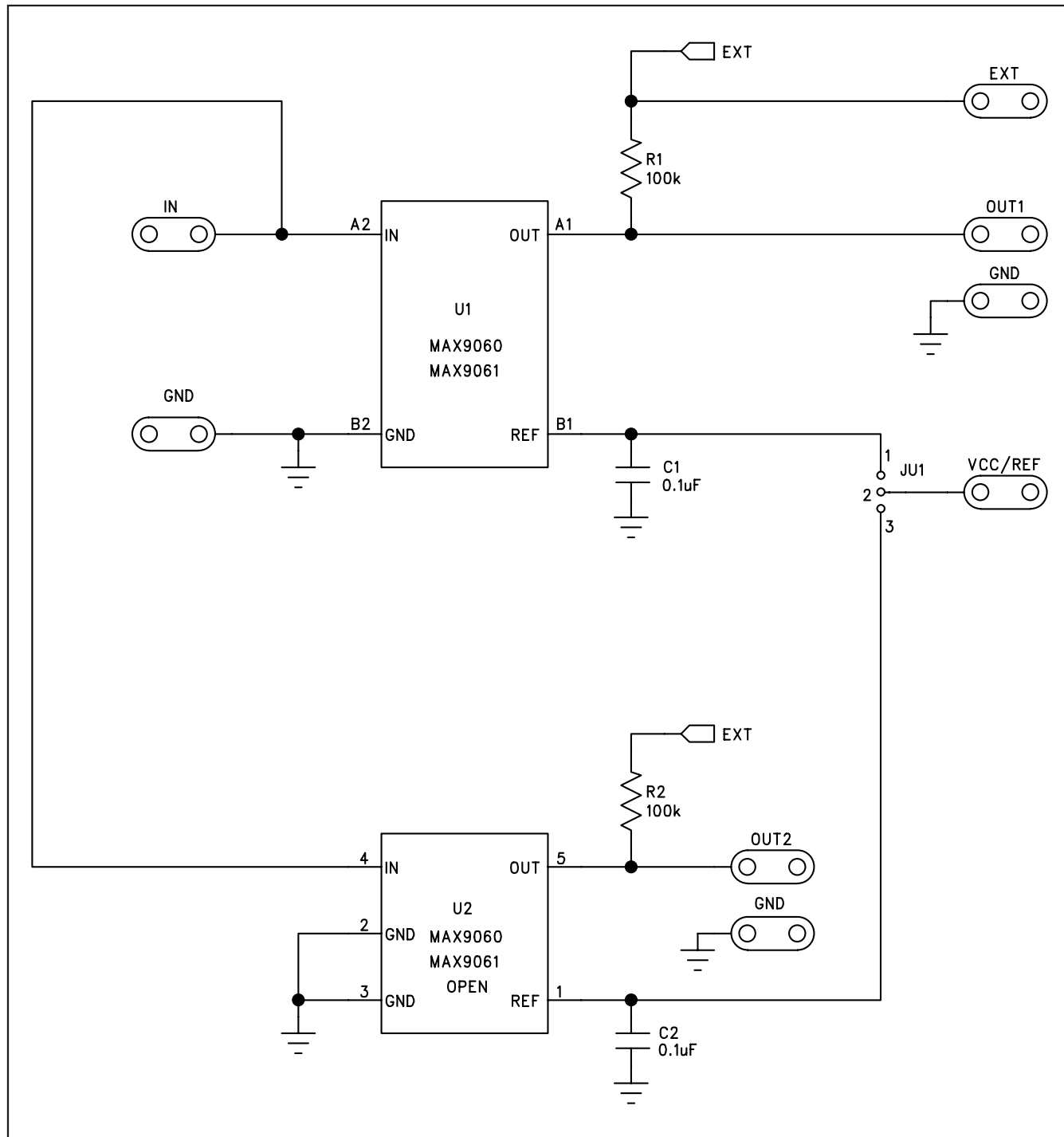

Figure 1. MAX9060/MAX9061 EV Kits Schematic

MAX9060-MAX9065 Evaluation Kits

Evaluate: MAX9060-MAX9065

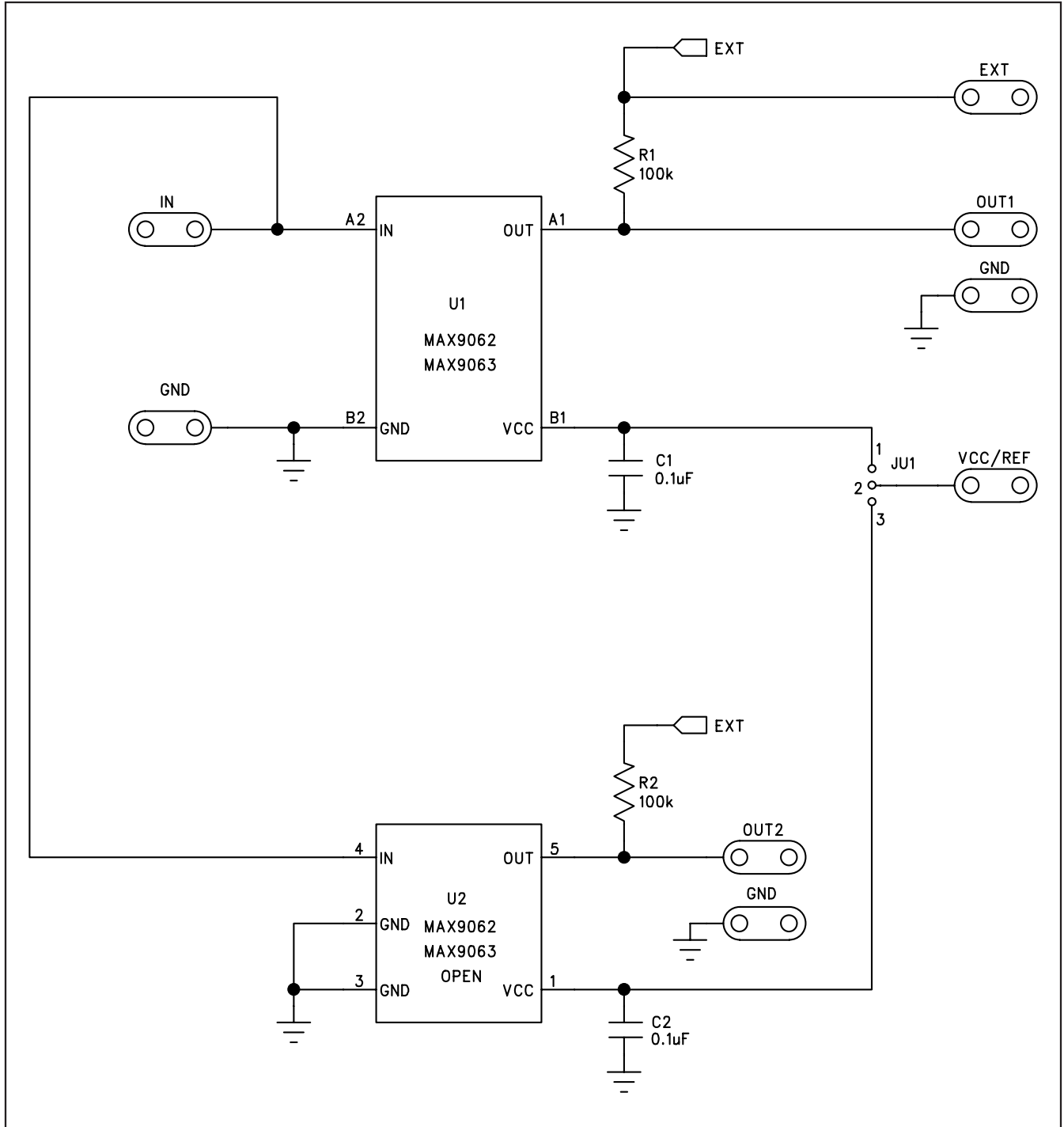

Figure 2. MAX9062/MAX9063 EV Kits Schematic

MAX9060–MAX9065 Evaluation Kits

Evaluate: MAX9060–MAX9065

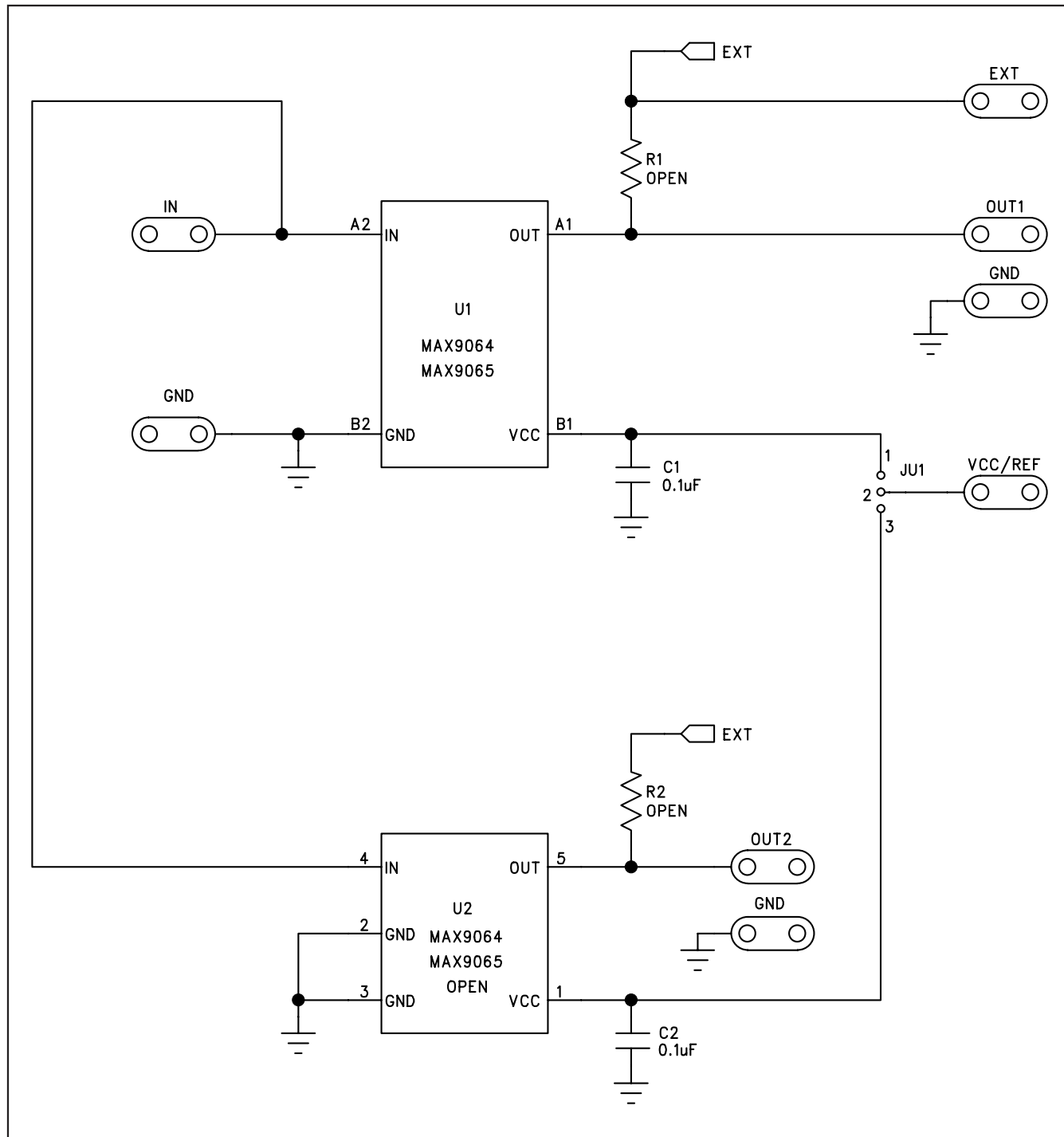

Figure 3. MAX9064/MAX9065 EV Kits Schematic

MAX9060-MAX9065 Evaluation Kits

Evaluate: MAX9060-MAX9065

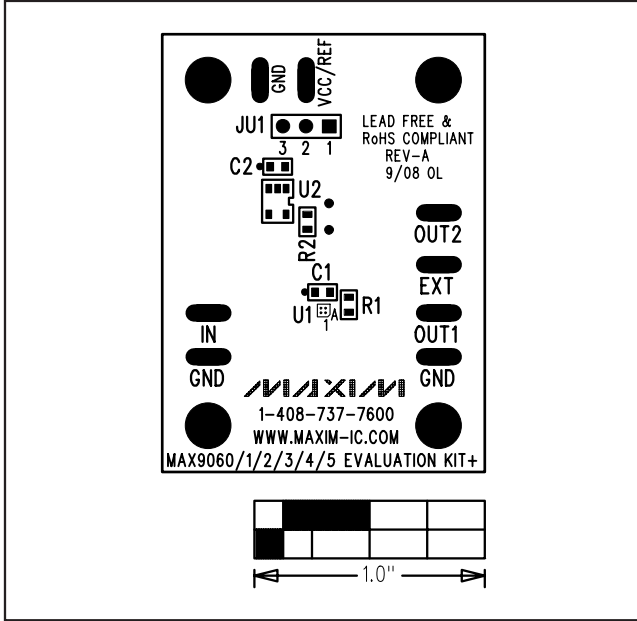

Figure 4. MAX9060-MAX9065 EV Kits PCB Layout—Component Placement Guide

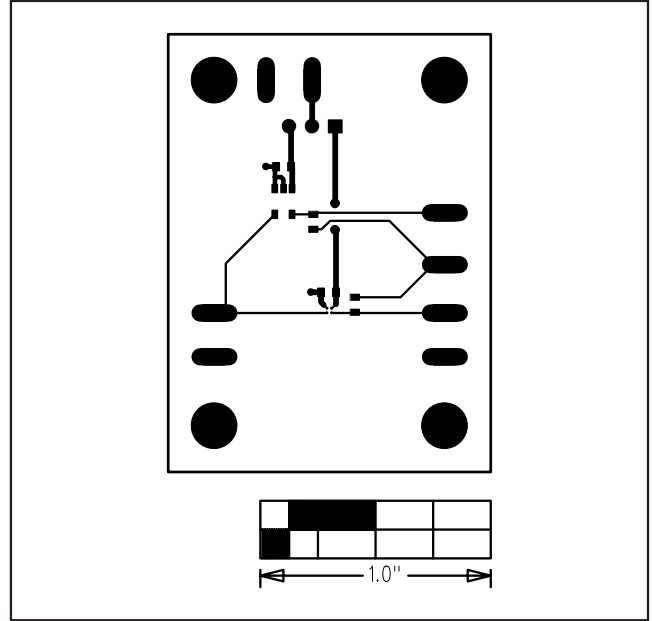

Figure 5. MAX9060-MAX9065 EV Kits PCB Layout—Component Side

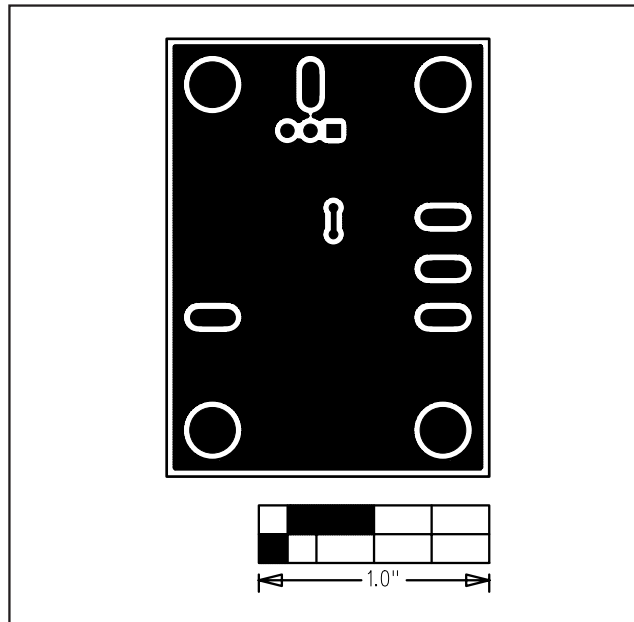

Figure 6. MAX9060-MAX9065 EV Kits PCB Layout—Solder Side

Maxim cannot assume responsibility for use of any circuitry other than circuitry entirely embodied in a Maxim product. No circuit patent licenses are implied. Maxim reserves the right to change the circuitry and specifications without notice at any time.

Maxim Integrated Products, 120 San Gabriel Drive, Sunnyvale, CA 94086 408-737-7600 _____ 7



Стандарт Электрон Связь

Мы молодая и активно развивающаяся компания в области поставок электронных компонентов. Мы поставляем электронные компоненты отечественного и импортного производства напрямую от производителей и с крупнейших складов мира.

Благодаря сотрудничеству с мировыми поставщиками мы осуществляем комплексные и плановые поставки широчайшего спектра электронных компонентов.

Собственная эффективная логистика и склад в обеспечивает надежную поставку продукции в точно указанные сроки по всей России.

Мы осуществляем техническую поддержку нашим клиентам и предпродажную проверку качества продукции. На все поставляемые продукты мы предоставляем гарантию .

Осуществляем поставки продукции под контролем ВП МО РФ на предприятия военно-промышленного комплекса России , а также работаем в рамках 275 ФЗ с открытием отдельных счетов в уполномоченном банке. Система менеджмента качества компании соответствует требованиям ГОСТ ISO 9001.

Минимальные сроки поставки, гибкие цены, неограниченный ассортимент и индивидуальный подход к клиентам являются основой для выстраивания долгосрочного и эффективного сотрудничества с предприятиями радиоэлектронной промышленности, предприятиями ВПК и научно-исследовательскими институтами России.

С нами вы становитесь еще успешнее!

Наши контакты:

Телефон: +7 812 627 14 35

Электронная почта: sales@st-electron.ru

Адрес: 198099, Санкт-Петербург,
Промышленная ул, дом № 19, литера Н,
помещение 100-Н Офис 331