

1/3-Inch CMOS Digital Image Sensor

MT9M021/MT9M031 Datasheet, Rev. G

For the latest datasheet revision, please visit www.onsemi.com

Features

- Superior low-light performance
- HD video (720p60)
- Global shutter
- Video/Single Frame mode
- Flexible row-skip modes
- On-chip AE and statistics engine
- Parallel and serial output
- Support for external LED or flash
- Auto black level calibration
- Context switching

Applications

- Scene processing
- Scanning and machine vision
- 720p60 video applications

General Description

The ON Semiconductor MT9M021/MT9M031 is a 1/3-inch CMOS digital image sensor with an active-pixel array of 1280H x 960V. It includes sophisticated camera functions such as auto exposure control, windowing, scaling, row skip mode, and both video and single frame modes. It is designed for low light performance and features a global shutter for accurate capture of moving scenes. It is programmable through a simple two-wire serial interface. The MT9M021/MT9M031 produces extraordinarily clear, sharp digital pictures, and its ability to capture both continuous video and single frames makes it the perfect choice for a wide range of applications, including scanning and HD video.

Table 1: Key Parameters

Parameter	Typical Value	
Optical format	1/3-inch (6 mm)	
Active pixels	1280 x 960 = 1.2 Mp	
Pixel size	3.75µm	
Color filter array	RGB Bayer or Monochrome	
Shutter type	Global shutter	
Input clock range	6 – 50 MHz	
Output pixel clock (maximum)	74.25 MHz	
Output	Serial	HiSPi (iBGA package only)
	Parallel	12-bit
Frame rate	Full resolution	45 fps
	720p	60 fps
Responsivity (Monochrome)	6.1 V/lux-sec	
Responsivity (Color)	5.3 V/lux-sec	
SNR _{MAX}	38 dB	
Dynamic range	64 dB	
Supply voltage	I/O	1.8 or 2.8 V
	Digital	1.8 V
	Analog	2.8 V
	HiSPi	0.4 V
Power consumption	<400 mW	
Operating temperature (ambient)	–30°C to +70°C	
Package options	9 x 9 mm 64-pin iBGA	
	10x10mm 48-pin iLCC	

Ordering Information

Table 2: Available Part Numbers

Part Number	Product Description	Orderable Product Attribute Description
MT9M021IA3XTC-DPBR	1.2 MP 1/3" GS CIS	Dry Pack with Protective Film, Double Side BBAR Glass
MT9M021IA3XTC-DRBR	1.2 MP 1/3" GS CIS	Dry Pack without Protective Film, Double Side BBAR Glass
MT9M021IA3XTM-DPBR	1.2 MP 1/3" GS CIS	Dry Pack with Protective Film, Double Side BBAR Glass
MT9M021IA3XTM-DRBR	1.2 MP 1/3" GS CIS	Dry Pack without Protective Film, Double Side BBAR Glass
MT9M021IA3XTMZ-DPBR	1.2 MP 1/3" GS CIS	Dry Pack with Protective Film, Double Side BBAR Glass
MT9M021IA3XTMZ-DRBR	1.2 MP 1/3" GS CIS	Dry Pack without Protective Film, Double Side BBAR Glass
MT9M021IA3XTMZ-TPBR	1.2 MP 1/3" GS CIS	Tape & Reel with Protective Film, Double Side BBAR Glass
MT9M031D00STMC24BC1-200	1 MP 1/6" SOC	Die Sales, 200 μm Thickness
MT9M031I12STC-DPBR	1 MP 1/6" SOC	Dry Pack with Protective Film, Double Side BBAR Glass
MT9M031I12STC-DRBR	1.2 MP 1/3" GS CIS	Dry Pack without Protective Film, Double Side BBAR Glass
MT9M031I12STM-DPBR	1.2 MP 1/3" GS CIS	Dry Pack with Protective Film, Double Side BBAR Glass
MT9M031I12STM-DRBR	1.2 MP 1/3" GS CIS	Dry Pack without Protective Film, Double Side BBAR Glass
MT9M031I12STMZ-DRBR	1.2 MP 1/3" GS CIS	Dry Pack without Protective Film, Double Side BBAR Glass

Table of Contents

Features	1
Applications	1
General Description	1
Ordering Information	2
General Description	8
Functional Overview	8
Features Overview	9
Electrical Specifications	16
Power-On Reset and Standby Timing	25
Package Dimensions	30
Revision History	32

List of Figures

Figure 1: Block Diagram 8
 Figure 2: Typical Configuration: Serial Four-Lane HiSPi Interface 10
 Figure 3: Typical Configuration: Parallel Pixel Data Interface 11
 Figure 4: 9x9mm 64-Ball iBGA Package 12
 Figure 5: 48 iLCC Package, Parallel Output 14
 Figure 6: Two-Wire Serial Bus Timing Parameters 16
 Figure 7: I/O Timing Diagram 18
 Figure 8: Differential Output Voltage for Clock or Data Pairs 23
 Figure 9: Eye Diagram for Clock and Data Signals 24
 Figure 10: Skew Within the PHY and Output Channels 24
 Figure 11: Power Up 25
 Figure 12: Power Down 26
 Figure 13: Quantum Efficiency – Monochrome Sensor 28
 Figure 14: Quantum Efficiency – Color Sensor 29
 Figure 15: 64-Ball iBGA Package Outline Drawing 30
 Figure 16: 48-pin iLCC Package Drawing 31

List of Tables

Table 1: Key Parameters 1
 Table 2: Available Part Numbers 2
 Table 3: Pin Descriptions - 64-Ball iBGA Package 13
 Table 4: Pin Descriptions - 48 iLCC Package, Parallel 15
 Table 5: Two-Wire Serial Bus Characteristics 17
 Table 6: I/O Timing Characteristics¹ 18
 Table 7: I/O Rise Slew Rate (2.8V V_{DD_IO})¹ 19
 Table 8: I/O Fall Slew Rate (2.8V V_{DD_IO})¹ 20
 Table 9: I/O Rise Slew Rate (1.8V V_{DD_IO})¹ 20
 Table 10: I/O Fall Slew Rate (1.8V V_{DD_IO})¹ 20
 Table 11: DC Electrical Characteristics 21
 Table 12: Absolute Maximum Ratings 21
 Table 13: Operating Current Consumption for Parallel Output 21
 Table 14: Standby Current Consumption 22
 Table 15: Input Voltage and Current (HiSPi Power Supply 0.4 V) 22
 Table 16: Rise and Fall Times 23
 Table 17: Power-Up Sequence 25
 Table 18: Power-Down Sequence 26

General Description

The ON Semiconductor MT9M021/MT9M031 can be operated in its default mode or programmed for frame size, exposure, gain, and other parameters. The default mode output is a full-resolution image at 45 frames per second (fps). It outputs 12-bit raw data, using either the parallel or serial (HiSPi) output ports. The device may be operated in video (master) mode or in frame trigger mode.

FRAME_VALID and LINE_VALID signals are output on dedicated pins, along with a synchronized pixel clock. A dedicated FLASH pin can be programmed to control external LED or flash exposure illumination.

The MT9M021/MT9M031 includes additional features to allow application-specific tuning: windowing, adjustable auto-exposure control, auto black level correction, on-board temperature sensor, and row skip and digital binning modes.

The sensor is designed to operate in a wide temperature range (−30°C to +70°C).

Functional Overview

The MT9M021/MT9M031 is a progressive-scan sensor that generates a stream of pixel data at a constant frame rate. It uses an on-chip, phase-locked loop (PLL) that can be optionally enabled to generate all internal clocks from a single master input clock running between 6 and 50 MHz. The maximum output pixel rate is 74.25 Mp/s, corresponding to a clock rate of 74.25 MHz. Figure 1 shows a block diagram of the sensor.

Figure 1: Block Diagram

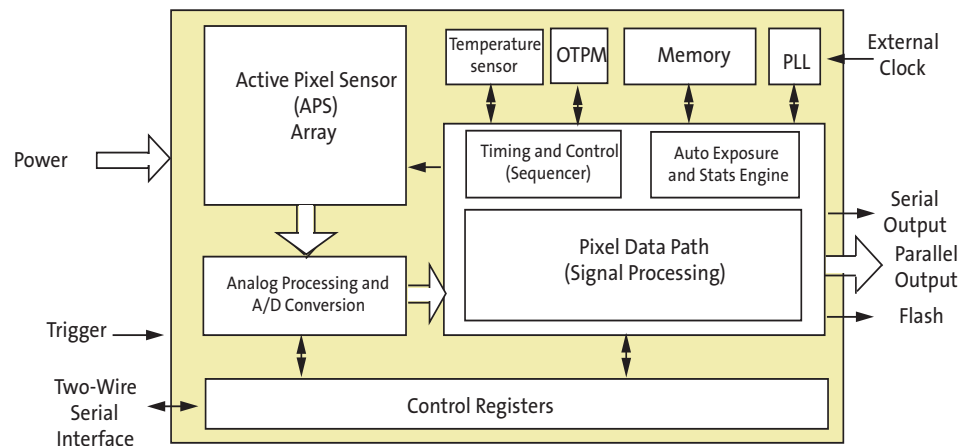

User interaction with the sensor is through the two-wire serial bus, which communicates with the array control, analog signal chain, and digital signal chain. The core of the sensor is a 1.2 Mp Active-Pixel Sensor array. The MT9M021/MT9M031 features global shutter technology for accurate capture of moving images. The exposure of the entire array is controlled by programming the integration time by register setting. All rows simultaneously integrate light prior to readout. Once a row has been read, the data from the columns is sequenced through an analog signal chain (providing offset correction and gain), and then through an analog-to-digital converter (ADC). The output from the ADC is a 12-bit value for each pixel in the array. The ADC output passes through a digital

processing signal chain (which provides further data path corrections and applies digital gain). The pixel data are output at a rate of up to 74.25 Mp/s, in parallel to frame and line synchronization signals.

Features Overview

The MT9M021/MT9M031 Global Sensor shutter has a wide array of features to enhance functionality and to increase versatility. A summary of features follows. Please refer to the MT9M021/MT9M031 Developer Guide for detailed feature descriptions, register settings, and tuning guidelines and recommendations.

- **Operating Modes**

The MT9M021/MT9M031 works in master (video), trigger (single frame), or Auto Trigger modes. In master mode, the sensor generates the integration and readout timing. In trigger mode, it accepts an external trigger to start exposure, then generates the exposure and readout timing. The exposure time is programmed through the two-wire serial interface for both modes.

Note: Trigger mode is not compatible with the HiSPi interface.

- **Window Control**

Configurable window size and blanking times allow a wide range of resolutions and frame rates. Digital binning and skipping modes are supported, as are vertical and horizontal mirror operations.

- **Context Switching**

Context switching may be used to rapidly switch between two sets of register values. Refer to the MT9M021/MT9M031 Developer Guide for a complete set of context switchable registers.

- **Gain**

The MT9M021/MT9M031 Global Shutter sensor can be configured for analog gain of up to 8x, and digital gain of up to 8x.

- **Automatic Exposure Control**

The integrated automatic exposure control may be used to ensure optimal settings of exposure and gain are computed and updated every other frame. Refer to the MT9M021/MT9M031 Developer Guide for more details.

- **HiSPi**

The MT9M021/MT9M031 Global Shutter image sensor supports two or three lanes of Streaming-SP or Packetized-SP protocols of ON Semiconductor's High-Speed Serial Pixel Interface.

- **PLL**

An on chip PLL provides reference clock flexibility and supports spread spectrum sources for improved EMI performance.

- **Reset**

The MT9M021/MT9M031 may be reset by a register write, or by a dedicated input pin.

- **Output Enable**

The MT9M021/MT9M031 output pins may be tri-stated using a dedicated output enable pin.

- **Temperature Sensor**

- **Black Level Correction**

- **Row Noise Correction**

- **Column Correction**

- **Test Patterns**

Several test patterns may be enabled for debug purposes. These include a solid color, color bar, fade to grey, and a walking 1s test pattern.

Figure 2: Typical Configuration: Serial Four-Lane HiSPi Interface

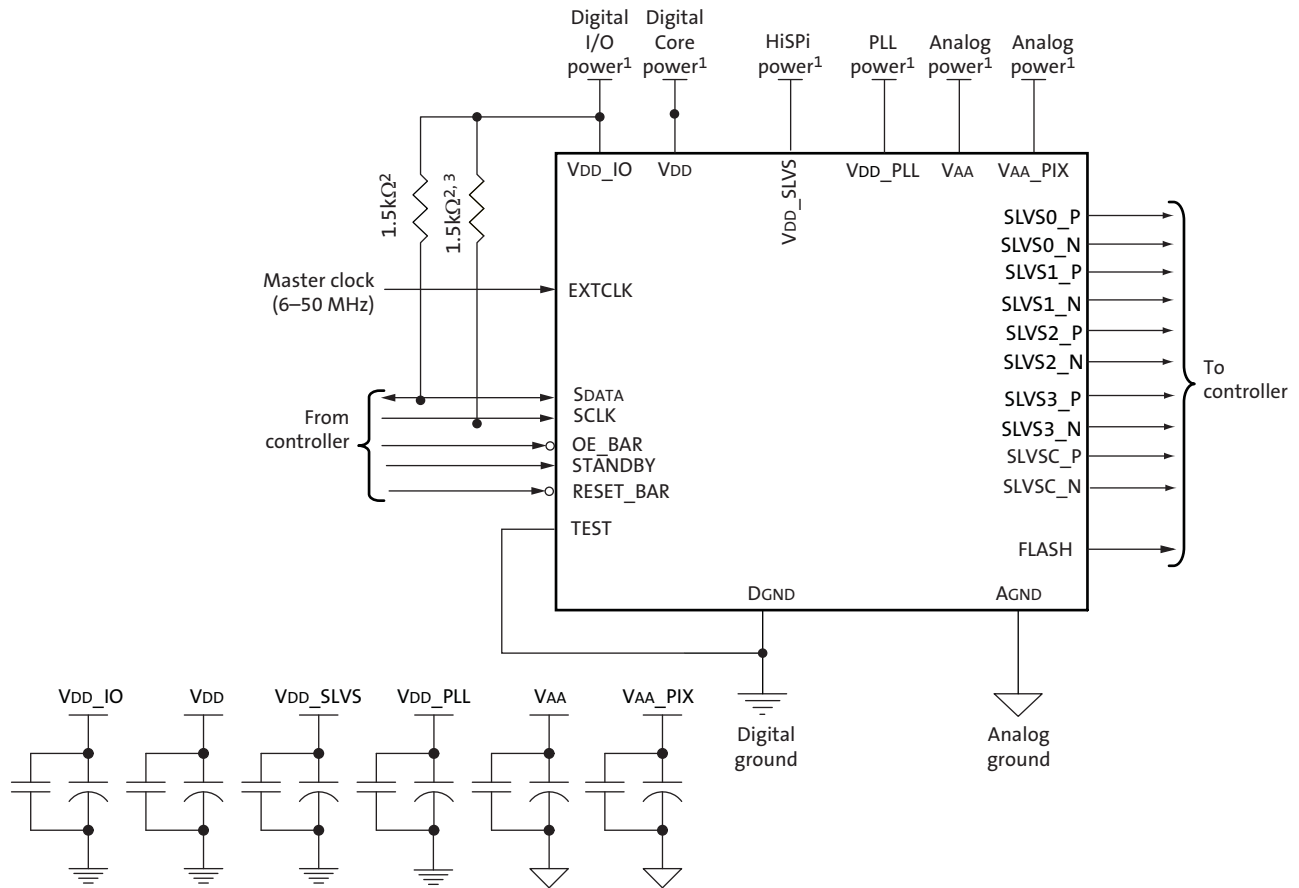

- Notes:
1. All power supplies must be adequately decoupled.
 2. ON Semiconductor recommends a resistor value of 1.5kΩ, but it may be greater for slower two-wire speed.
 3. This pull-up resistor is not required if the controller drives a valid logic level on SCLK at all times.
 4. The parallel interface output pads can be left unconnected if the serial output interface is used.
 5. ON Semiconductor recommends that 0.1μF and 10μF decoupling capacitors for each power supply are mounted as close as possible to the pad. Actual values and results may vary depending on layout and design considerations. Refer to the MT9M021/MT9M031 demo headboard schematics for circuit recommendations.
 6. ON Semiconductor recommends that analog power planes be placed in a manner such that coupling with the digital power planes is minimized.
 7. Although 4 serial lanes are shown, the MT9M021/MT9M031 supports only 2 or 3 lane HiSPi.

Figure 3: Typical Configuration: Parallel Pixel Data Interface

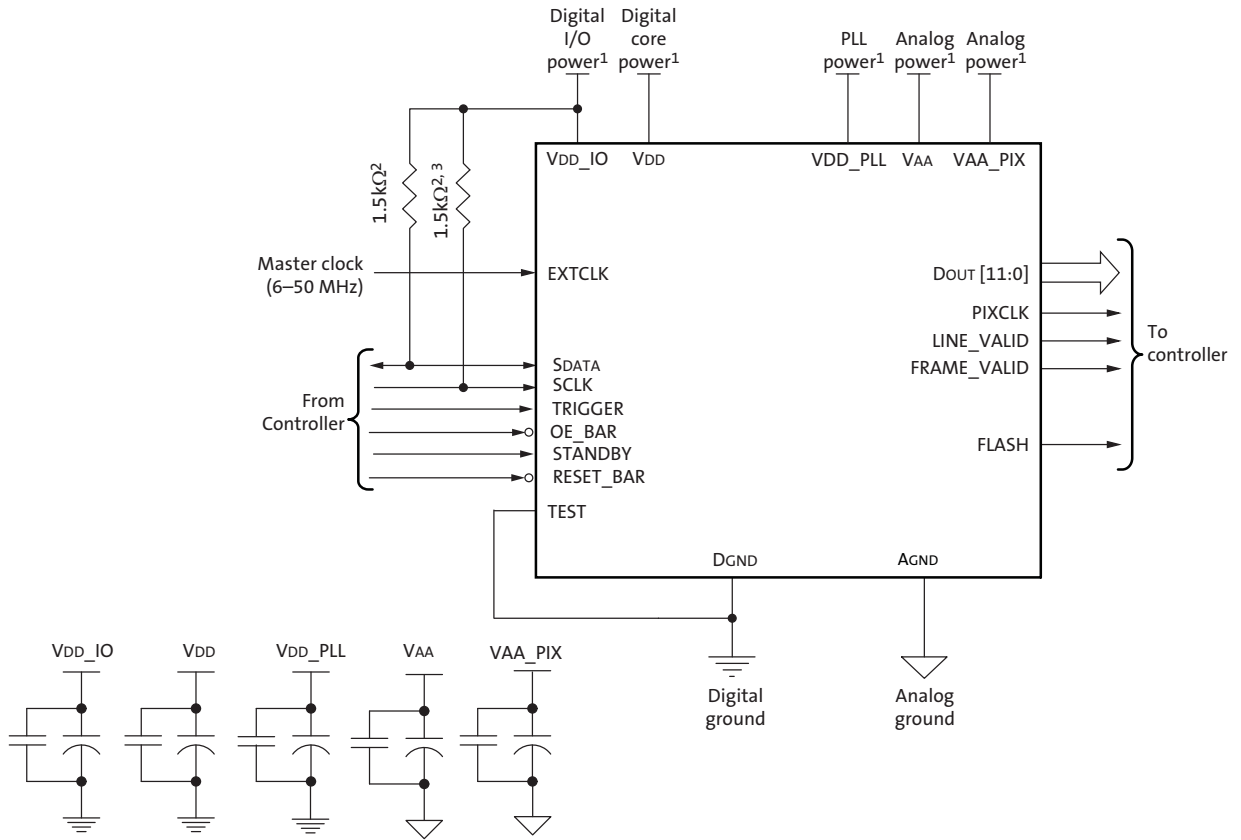

- Notes:
1. All power supplies must be adequately decoupled.
 2. ON Semiconductor recommends a resistor value of 1.5kΩ, but it may be greater for slower two-wire speed.
 3. This pull-up resistor is not required if the controller drives a valid logic level on SCLK at all times.
 4. The serial interface output pads can be left unconnected if the parallel output interface is used.
 5. ON Semiconductor recommends that 0.1μF and 10μF decoupling capacitors for each power supply are mounted as close as possible to the pad. Actual values and results may vary depending on layout and design considerations. Refer to the MT9M021/MT9M031 demo headboard schematics for circuit recommendations.
 6. ON Semiconductor recommends that analog power planes be placed in a manner such that coupling with the digital power planes is minimized.

Figure 4: 9x9mm 64-Ball iBGA Package

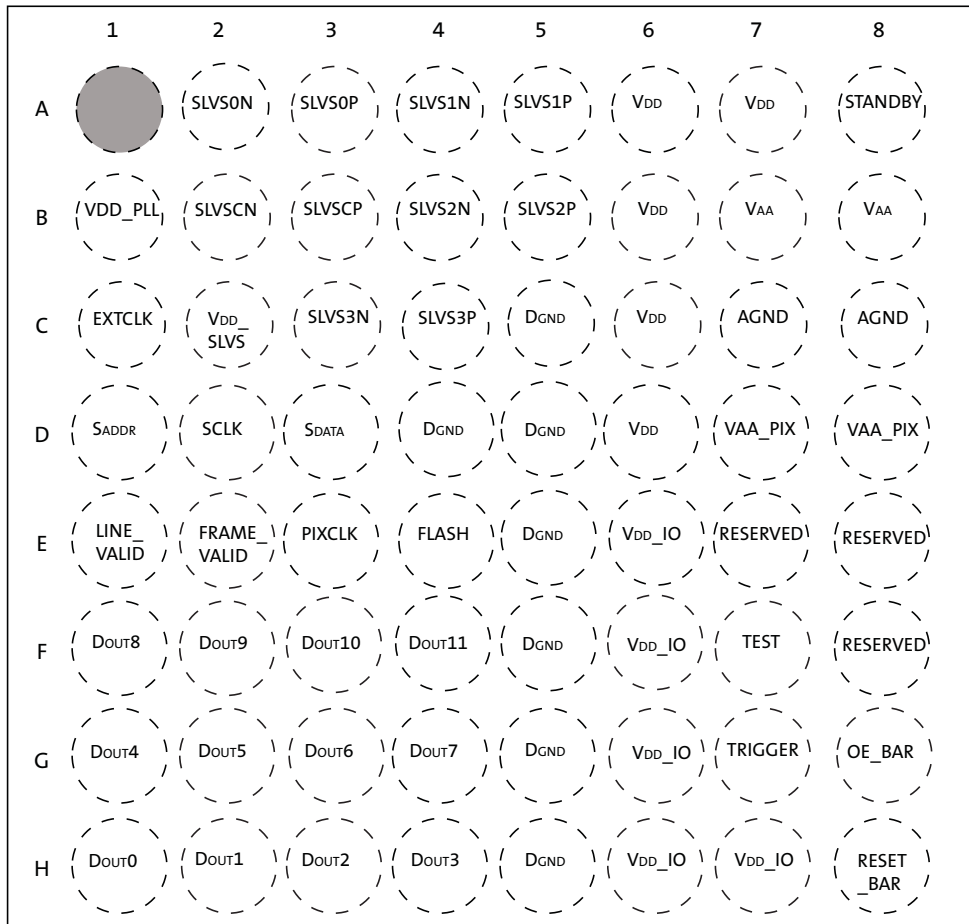

Top View
(Ball Down)

Table 3: Pin Descriptions - 64-Ball iBGA Package

Name	iBGA Pin	Type	Description
SLVS0_N	A2	Output	HiSPi serial data, lane 0, differential N.
SLVS0_P	A3	Output	HiSPi serial data, lane 0, differential P.
SLVS1_N	A4	Output	HiSPi serial data, lane 1, differential N.
SLVS1_P	A5	Output	HiSPi serial data, lane 1, differential P.
STANDBY	A8	Input	Standby-mode enable pin (active HIGH).
VDD_PLL	B1	Power	PLL power.
SLVSC_N	B2	Output	HiSPi serial DDR clock differential N.
SLVSC_P	B3	Output	HiSPi serial DDR clock differential P.
SLVS2_N	B4	Output	HiSPi serial data, lane 2, differential N.
SLVS2_P	B5	Output	HiSPi serial data, lane 2, differential P.
VAA	B7, B8	Power	Analog power.
EXTCLK	C1	Input	External input clock.
VDD_SLVS	C2	Power	HiSPi power.
SLVS3_N	C3	Output	HiSPi serial data, lane 3, differential N.
SLVS3_P	C4	Output	HiSPi serial data, lane 3, differential P.
DGND	C5, D4, D5, E5, F5, G5, H5	Power	Digital GND.
VDD	A6, A7, B6, C6, D6	Power	Digital power.
AGND	C7, C8	Power	Analog GND.
SADDR	D1	Input	Two-Wire Serial address select.
SCLK	D2	Input	Two-Wire Serial clock input.
SDATA	D3	I/O	Two-Wire Serial data I/O.
VAA_PIX	D7, D8	Power	Pixel power.
LINE_VALID	E1	Output	Asserted when DOUT line data is valid.
FRAME_VALID	E2	Output	Asserted when DOUT frame data is valid.
PIXCLK	E3	Output	Pixel clock out. DOUT is valid on rising edge of this clock.
FLASH	E4	Output	Control signal to drive external light sources.
VDD_IO	E6, F6, G6, H6, H7	Power	I/O supply power.
DOUT8	F1	Output	Parallel pixel data output.
DOUT9	F2	Output	Parallel pixel data output.
DOUT10	F3	Output	Parallel pixel data output.
DOUT11	F4	Output	Parallel pixel data output (MSB)
TEST	F7	Input	Manufacturing test enable pin (connect to DGND).
DOUT4	G1	Output	Parallel pixel data output.
DOUT5	G2	Output	Parallel pixel data output.
DOUT6	G3	Output	Parallel pixel data output.
DOUT7	G4	Output	Parallel pixel data output.
TRIGGER	G7	Input	Exposure synchronization input.
OE_BAR	G8	Input	Output enable (active LOW).
DOUT0	H1	Output	Parallel pixel data output (LSB)
DOUT1	H2	Output	Parallel pixel data output.
DOUT2	H3	Output	Parallel pixel data output.
DOUT3	H4	Output	Parallel pixel data output.

Table 3: Pin Descriptions (continued)- 64-Ball iBGA Package

Name	iBGA Pin	Type	Description
RESET_BAR	H8	Input	Asynchronous reset (active LOW). All settings are restored to factory default.
Reserved	E7, E8, F8	n/a	Reserved (do not connect).

Figure 5: 48 iLCC Package, Parallel Output

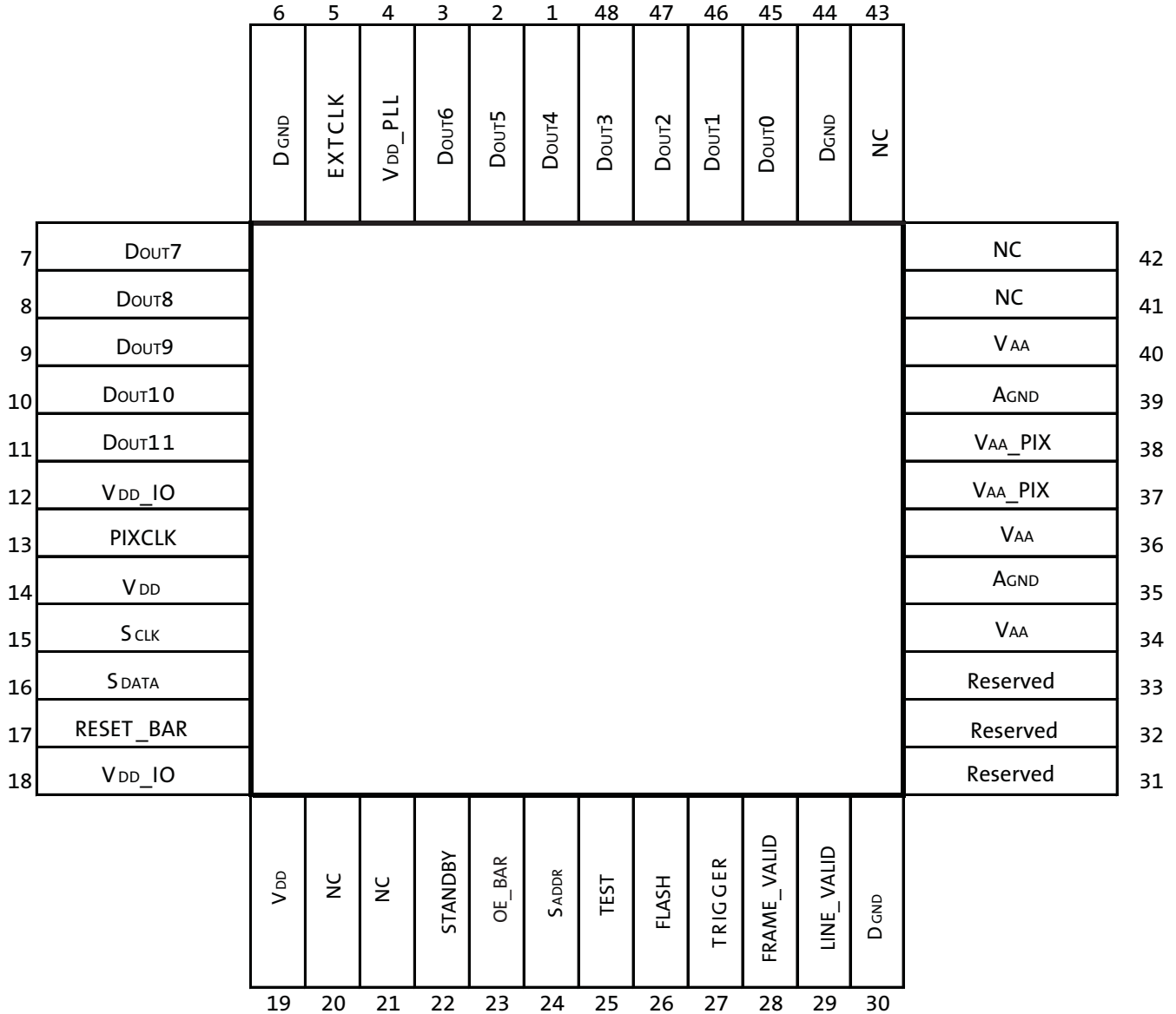

Table 4: Pin Descriptions - 48 iLCC Package, Parallel

Pin Number	Name	Type	Description
1	DOUT4	Output	Parallel pixel data output.
2	DOUT5	Output	Parallel pixel data output.
3	DOUT6	Output	Parallel pixel data output.
4	VDD_PLL	Power	PLL power.
5	EXTCLK	Input	External input clock.
6	DGND	Power	Digital ground.
7	DOUT7	Output	Parallel pixel data output.
8	DOUT8	Output	Parallel pixel data output.
9	DOUT9	Output	Parallel pixel data output.
10	DOUT10	Output	Parallel pixel data output.
11	DOUT11	Output	Parallel pixel data output (MSB).
12	VDD_IO	Power	I/O supply power.
13	PIXCLK	Output	Pixel clock out. DOUT is valid on rising edge of this clock.
14	VDD	Power	Digital power.
15	SCLK	Input	Two-Wire Serial clock input.
16	SDATA	I/O	Two-Wire Serial data I/O.
17	RESET_BAR	Input	Asynchronous reset (active LOW). All settings are restored to factory default.
18	VDD_IO	Power	I/O supply power.
19	VDD	Power	Digital power.
20	NC		No connection.
21	NC		No connection.
22	STANDBY	Input	Standby-mode enable pin (active HIGH).
23	OE_BAR	Input	Output enable (active LOW).
24	SADDR	Input	Two-Wire Serial address select.
25	TEST	Input	Manufacturing test enable pin (connect to DGND).
26	FLASH	Output	Flash output control.
27	TRIGGER	Input	Exposure synchronization input.
28	FRAME_VALID	Output	Asserted when DOUT frame data is valid.
29	LINE_VALID	Output	Asserted when DOUT line data is valid.
30	DGND	Power	Digital ground
31	Reserved	n/a	Reserved (do not connect).
32	Reserved	n/a	Reserved (do not connect).
33	Reserved	n/a	Reserved (do not connect).
34	VAA	Power	Analog power.
35	AGND	Power	Analog ground.
36	VAA	Power	Analog power.
37	VAA_PIX	Power	Pixel power.
38	VAA_PIX	Power	Pixel power.
39	AGND	Power	Analog ground.
40	VAA	Power	Analog power.
41	NC		No connection.
42	NC		No connection.

Table 4: Pin Descriptions (continued)- 48 iLCC Package, Parallel

Pin Number	Name	Type	Description
43	NC		No connection.
44	DGND	Power	Digital ground.
45	DOUT0	Output	Parallel pixel data output (LSB)
46	DOUT1	Output	Parallel pixel data output.
47	DOUT2	Output	Parallel pixel data output.
48	DOUT3	Output	Parallel pixel data output.

Electrical Specifications

Unless otherwise stated, the following specifications apply to the following conditions:

$V_{DD} = 1.8V - 0.10/+0.15$; $V_{DD_IO} = V_{DD_PLL} = V_{AA} = V_{AA_PIX} = 2.8V \pm 0.3V$;
 $V_{DD_SLVS} = 0.4V - 0.1/+0.2$; $T_A = -30^{\circ}C$ to $+70^{\circ}C$; output load = 10pF;
 PIXCLK frequency = 74.25 MHz; HiSPi off.

Two-Wire Serial Register Interface

The electrical characteristics of the two-wire serial register interface (SCLK, SDATA) are shown in Figure 6 and Table 5.

Figure 6: Two-Wire Serial Bus Timing Parameters

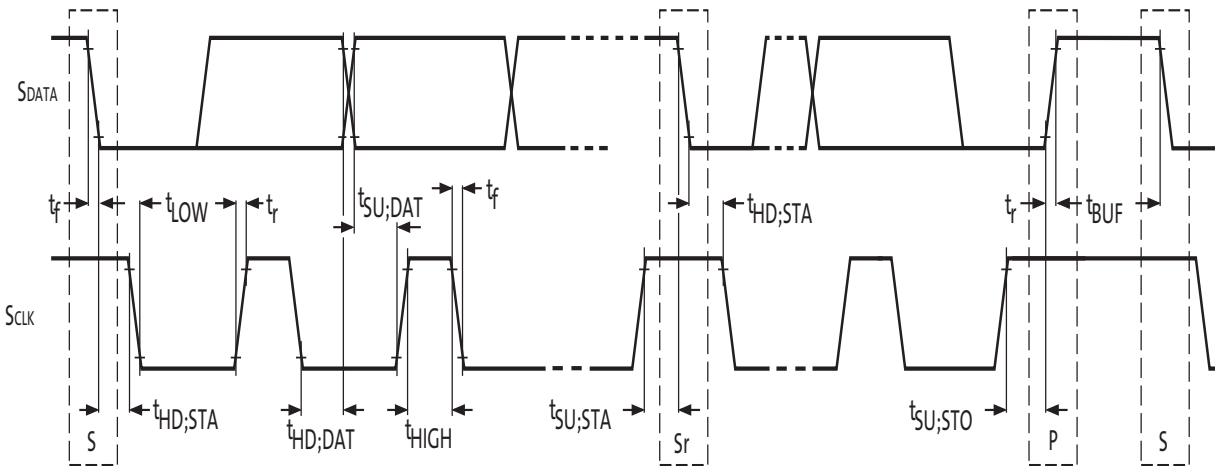

Note: Read sequence: For an 8-bit READ, read waveforms start after WRITE command and register address are issued.

Table 5: Two-Wire Serial Bus Characteristics

$f_{EXTCLK} = 27 \text{ MHz}$; $V_{DD} = 1.8\text{V}$; $V_{DD_IO} = 2.8\text{V}$; $V_{AA} = 2.8\text{V}$; $V_{AA_PIX} = 2.8\text{V}$;
 $V_{DD_PLL} = 2.8\text{V}$; $T_A = 25^\circ\text{C}$

Parameter	Symbol	Standard-Mode		Fast-Mode		Unit
		Min	Max	Min	Max	
SCLK Clock Frequency	t_{SCL}	0	100	0	400	KHz
Hold time (repeated) START condition.						
After this period, the first clock pulse is generated	$t_{HD;STA}$	4.0	-	0.6	-	μS
LOW period of the SCLK clock	t_{LOW}	4.7	-	1.3	-	μS
HIGH period of the SCLK clock	t_{HIGH}	4.0	-	0.6	-	μS
Set-up time for a repeated START condition	$t_{SU;STA}$	4.7	-	0.6	-	μS
Data hold time:	$t_{HD;DAT}$	0 ⁴	3.45 ⁵	0 ⁶	0.9 ⁵	μS
Data set-up time	$t_{SU;DAT}$	250	-	100 ⁶	-	nS
Rise time of both SDATA and SCLK signals	t_r	-	1000	$20 + 0.1Cb^7$	300	nS
Fall time of both SDATA and SCLK signals	t_f	-	300	$20 + 0.1Cb^7$	300	nS
Set-up time for STOP condition	$t_{SU;STO}$	4.0	-	0.6	-	μS
Bus free time between a STOP and START condition	t_{BUF}	4.7	-	1.3	-	μS
Capacitive load for each bus line	C_b	-	400	-	400	pF
Serial interface input pin capacitance	C_{IN_SI}	-	3.3	-	3.3	pF
SDATA max load capacitance	C_{LOAD_SD}	-	30	-	30	pF
SDATA pull-up resistor	RSD	1.5	4.7	1.5	4.7	$K\Omega$

- Notes:
1. This table is based on I²C standard (v2.1 January 2000). Philips Semiconductor.
 2. Two-wire control is I²C-compatible.
 3. All values referred to $V_{IHmin} = 0.9 V_{DD}$ and $V_{ILmax} = 0.1V_{DD}$ levels. Sensor EXCLK = 27 MHz.
 4. A device must internally provide a hold time of at least 300 ns for the SDATA signal to bridge the undefined region of the falling edge of SCLK.
 5. The maximum $t_{HD;DAT}$ has only to be met if the device does not stretch the LOW period (t_{LOW}) of the SCLK signal.
 6. A Fast-mode I²C-bus device can be used in a Standard-mode I²C-bus system, but the requirement $t_{SU;DAT} = 250 \text{ ns}$ must then be met. This will automatically be the case if the device does not stretch the LOW period of the SCLK signal. If such a device does stretch the LOW period of the SCLK signal, it must output the next data bit to the SDATA line $t_r \text{ max} + t_{SU;DAT} = 1000 + 250 = 1250 \text{ ns}$ (according to the Standard-mode I²C-bus specification) before the SCLK line is released.
 7. C_b = total capacitance of one bus line in pF.

I/O Timing

By default, the MT9M021/MT9M031 launches pixel data, FV and LV with the falling edge of PIXCLK. The expectation is that the user captures DOUT[11:0], FV and LV using the rising edge of PIXCLK. The launch edge of PIXCLK can be configured in register R0x3028.

See Figure 7 below and Table 6 on page 18 for I/O timing (AC) characteristics.

Figure 7: I/O Timing Diagram

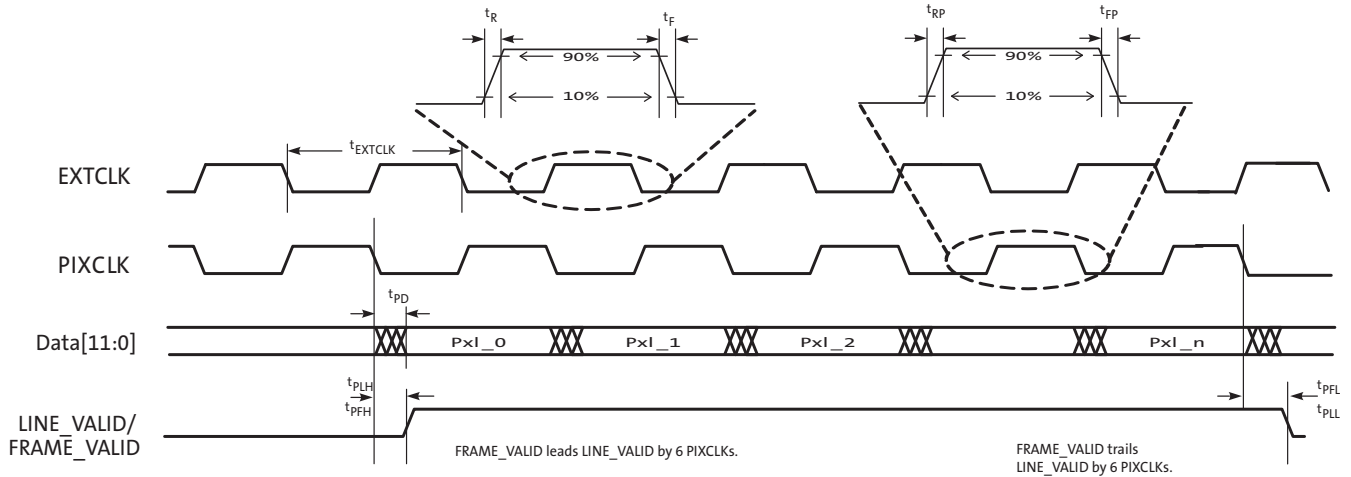

Table 6: I/O Timing Characteristics¹

Parallel Output									
Symbol	Definition	Condition	VDD_IO=2.8V			VDD_IO=1.8V			Unit
			Min	Typ	Max	Min	Typ	Max	
f_{EXTCLK}	Input clock frequency		6		50	6		50	MHz
t_{EXTCLK}	Input clock period		20		166	20		166	ns
t_R	Input clock rise time	PLL enabled		3	4		3	4	ns
t_F	Input clock fall time	PLL enabled		3	4		3	4	ns
t_{RP}	PIXCLK rise time	Slew setting = 4 (default)	2.3		4.6	2.3		4.6	ns
t_{FP}	PIXCLK fall time	Slew setting = 4 (default)	3		4.4	3		4.4	ns
	PIXCLK duty cycle		40	50	60	40	50	60	%
f_{PIXCLK}	PIXCLK frequency ²	Nominal voltages, PLL Enabled	6		74.25	6		74.25	MHz
t_{PD}	PIXCLK to data valid	Nominal voltages, PLL Enabled	-3	2.3	4	-3	2.3	4.5	ns

Table 6: I/O Timing Characteristics¹ (continued)

Parallel Output									
Symbol	Definition	Condition	V _{DD_IO} =2.8V			V _{DD_IO} =1.8V			Unit
			Min	Typ	Max	Min	Typ	Max	
t _{PFH}	PIXCLK to FV HIGH	Nominal voltages, PLL Enabled	-3	1.5	4	-3	1.5	4.5	ns
t _{PLH}	PIXCLK to LV HIGH	Nominal voltages, PLL Enabled	-3	2.3	4	-3	2.3	4.5	ns
t _{PFL}	PIXCLK to FV LOW	Nominal voltages, PLL Enabled	-3	1.5	4	-3	1.5	4.5	ns
t _{PLL}	PIXCLK to LV LOW	Nominal voltages, PLL Enabled	-3	2	4	-3	2	4.5	ns

- Notes:
1. Minimum and maximum values are taken at the temperature and voltage limits; for instance, 70°C ambient at 90% of V_{DD_IO}, and -30°C at 110% of V_{DD_IO}. All values are taken at the 50% transition point. The loading used is 20pF.
 2. Jitter from PIXCLK is already taken into account as the data of all the output parameters.

Table 7: I/O Rise Slew Rate (2.8V V_{DD_IO})¹

Parallel Slew Rate (R0x306E[15:13])	Conditions	Min	Typ	Max	Units
7	Default	1.08	1.77	2.72	V/ns
6	Default	0.77	1.26	1.94	V/ns
5	Default	0.58	0.95	1.46	V/ns
4	Default	0.44	0.70	1.08	V/ns
3	Default	0.32	0.51	0.78	V/ns
2	Default	0.23	0.37	0.56	V/ns
1	Default	0.16	0.25	0.38	V/ns
0	Default	0.10	0.15	0.22	V/ns

- Note:
1. Minimum and maximum values are taken at the temperature and voltage limits; for instance, 70°C ambient at 90% of V_{DD_IO}, and -30°C at 110% of V_{DD_IO}. All values are taken at the 50% transition point. The loading used is 20pF.

Table 8: I/O Fall Slew Rate (2.8V VDD_IO)¹

Parallel Slew Rate (R0x306E[15:13])	Conditions	Min	Typ	Max	Units
7	Default	1.00	1.62	2.41	V/ns
6	Default	0.76	1.24	1.88	V/ns
5	Default	0.60	0.98	1.50	V/ns
4	Default	0.46	0.75	1.16	V/ns
3	Default	0.35	0.56	0.86	V/ns
2	Default	0.25	0.40	0.61	V/ns
1	Default	0.17	0.27	0.41	V/ns
0	Default	0.11	0.16	0.24	V/ns

Note: 1. Minimum and maximum values are taken at the temperature and voltage limits; for instance, 70°C ambient at 90% of VDD_IO, and -30°C at 110% of VDD_IO. All values are taken at the 50% transition point. The loading used is 20pF.

Table 9: I/O Rise Slew Rate (1.8V VDD_IO)¹

Parallel Slew Rate (R0x306E[15:13])	Conditions	Min	Typ	Max	Units
7	Default	0.41	0.65	1.10	V/ns
6	Default	0.30	0.47	0.79	V/ns
5	Default	0.24	0.37	0.61	V/ns
4	Default	0.19	0.28	0.46	V/ns
3	Default	0.14	0.21	0.34	V/ns
2	Default	0.10	0.15	0.24	V/ns
1	Default	0.07	0.10	0.16	V/ns
0	Default	0.04	0.06	0.10	V/ns

Note: 1. Minimum and maximum values are taken at the temperature and voltage limits; for instance, 70°C ambient at 90% of VDD_IO, and -30°C at 110% of VDD_IO. All values are taken at the 50% transition point. The loading used is 20pF.

Table 10: I/O Fall Slew Rate (1.8V VDD_IO)¹

Parallel Slew Rate (R0x306E[15:13])	Conditions	Min	Typ	Max	Units
7	Default	0.42	0.68	1.11	V/ns
6	Default	0.32	0.51	0.84	V/ns
5	Default	0.26	0.41	0.67	V/ns
4	Default	0.20	0.32	0.52	V/ns
3	Default	0.16	0.24	0.39	V/ns
2	Default	0.12	0.18	0.28	V/ns
1	Default	0.08	0.12	0.19	V/ns
0	Default	0.05	0.07	0.11	V/ns

Notes: 1. Minimum and maximum values are taken at the temperature and voltage limits; for instance, 70°C ambient at 90% of VDD_IO, and -30°C at 110% of VDD_IO. All values are taken at the 50% transition point. The loading used is 20pF.

DC Electrical Characteristics

The DC electrical characteristics are shown in Table 11, Table 12, Table 13, and Table 14.

Table 11: DC Electrical Characteristics

Symbol	Definition	Condition	Min	Typ	Max	Unit
VDD	Core digital voltage		1.7	1.8	1.95	V
VDD_IO	I/O digital voltage		1.7/2.5	1.8/2.8	1.9/3.1	V
VAA	Analog voltage		2.5	2.8	3.1	V
VAA_PIX	Pixel supply voltage		2.5	2.8	3.1	V
VDD_PLL	PLL supply voltage		2.5	2.8	3.1	V
VDD_SLVS	HiSPI supply voltage		0.3	0.4	0.6	V
VIH	Input HIGH voltage		$V_{DD_IO} * 0.7$	–	–	V
VIL	Input LOW voltage		–	–	$V_{DD_IO} * 0.3$	V
IIN	Input leakage current	No pull-up resistor; $V_{IN} = V_{DD_IO}$ or DGND	20	–	–	μA
VOH	Output HIGH voltage		$V_{DD_IO} - 0.3$	–	–	V
VOL	Output LOW voltage	$V_{DD_IO} = 2.8V$	–	–	0.4	V
IOH	Output HIGH current	At specified VOH	–22	–	–	mA
IOL	Output LOW current	At specified VOL	–	–	22	mA

Caution Stresses greater than those listed in Table 12 may cause permanent damage to the device. This is a stress rating only, and functional operation of the device at these or any other conditions above those indicated in the operational sections of this specification is not implied.

Table 12: Absolute Maximum Ratings

Symbol	Parameter	Minimum	Maximum	Unit	Symbol
VSUPPLY	Power supply voltage (all supplies)	–0.3	4.5	V	VSUPPLY
ISUPPLY	Total power supply current	–	200	mA	ISUPPLY
IGND	Total ground current	–	200	mA	IGND
VIN	DC input voltage	–0.3	$V_{DD_IO} + 0.3$	V	VIN
VOUT	DC output voltage	–0.3	$V_{DD_IO} + 0.3$	V	VOUT
TSTG ¹	Storage temperature	–40	+85	°C	TSTG ¹

Note: 1. Exposure to absolute maximum rating conditions for extended periods may affect reliability.

Table 13: Operating Current Consumption for Parallel Output

$V_{AA} = V_{AA_PIX} = V_{DD_IO} = V_{DD_PLL} = 2.8V$; $V_{DD} = 1.8V$; PLL Enabled and PIXCLK = 74.25 MHz; $T_A = 25^\circ C$; $C_{LOAD} = 10pF$

	Condition	Symbol	Min	Typ	Max	Unit
Digital operating current	Parallel, Streaming, Full resolution 45 fps	IDD1		45	55	mA
I/O digital operating current	Parallel, Streaming, Full resolution 45 fps	IDD_IO		50 ¹	–	mA
Analog operating current	Parallel, Streaming, Full resolution 45 fps	IAA		45	50	mA
Pixel supply current	Parallel, Streaming, Full resolution 45 fps	IAA_PIX		6	10	mA
PLL supply current	Parallel, Streaming, Full resolution 45 fps	IDD_PLL		6	8	mA

Note: 1. IDD_IO operating current is specified with image at 1/2 saturation level.

Table 14: Standby Current Consumption
Analog - VAA + VAA_PIX + VDD_PLL; Digital - VDD + VDD_IO; T_A = 25°C

Definition	Condition	Min	Typ	Max	Unit
Hard standby (clock off, driven low)	Analog, 2.8V	–	3	10	μA
	Digital, 1.8V	–	8	75	μA
Hard standby (clock on, EXTCLK = 20 MHz)	Analog, 2.8V	–	12	20	μA
	Digital, 1.8V	–	0.87	1.3	mA
Soft standby (clock off, driven low)	Analog, 2.8V	–	3	10	μA
	Digital, 1.8V	–	8	75	μA
Soft standby (clock on, EXTCLK = 20 MHz)	Analog, 2.8V	–	12	20	μA
	Digital, 1.8V	–	0.87	1.3	mA

HiSPi Electrical Specifications

The ON Semiconductor MT9M021/MT9M031 sensor supports SLVS mode only, and does not have a DLL for timing adjustments. Refer to the High-Speed Serial Pixel (HiSPi) Interface Physical Layer Specification v2.00.00 for electrical definitions, specifications, and timing information. The VDD_SLVS supply in this datasheet corresponds to VDD_TX in the HiSPi Physical Layer Specification. Similarly, VDD is equivalent to VDD_HiSPi as referenced in the specification. The HiSPi transmitter electrical specifications are listed at 700 MHz.

Table 15: Input Voltage and Current (HiSPi Power Supply 0.4 V)
Measurement Conditions: Max Freq 700 MHz

Parameter	Symbol	Min	Typ	Max	Unit
Supply current (PWRHiSPi) (driving 100Ω load)	I _{DD_SLVS}	–	10	15	mA
HiSPi common mode voltage (driving 100Ω load)	V _{CM}	V _{DD_SLVS} x 0.45	V _{DD_SLVS} /2	V _{DD_SLVS} x 0.55	V
HiSPi differential output voltage (driving 100Ω load)	V _{OD}	V _{DD_SLVS} x 0.36	V _{DD_SLVS} /2	V _{DD_SLVS} x 0.64	V
Change in V _{CM} between logic 1 and 0	ΔV _{CM}			25	mV
Change in V _{OD} between logic 1 and 0	V _{OD}			25	mV
V _{od} noise margin	NM	–		30	%
Difference in V _{CM} between any two channels	ΔV _{CM}			50	mV
Difference in V _{OD} between any two channels	ΔV _{OD}			100	mV
Common-mode AC voltage (pk) without V _{CM} cap termination	ΔV _{CM_ac}			50	mV
Common-mode AC voltage (pk) with V _{CM} cap termination	ΔV _{CM_ac}			30	mV
Max overshoot peak V _{OD}	V _{OD_ac}			1.3 x V _{OD}	V
Max overshoot V _{diff} pk-pk	V _{diff_pkpk}			2.6 x V _{OD}	V
Eye Height	V _{eye}	1.4 x V _{OD}			
Single-ended output impedance	R _o	35	50	70	Ω
Output impedance mismatch	ΔR _o			20	%

Figure 8: Differential Output Voltage for Clock or Data Pairs

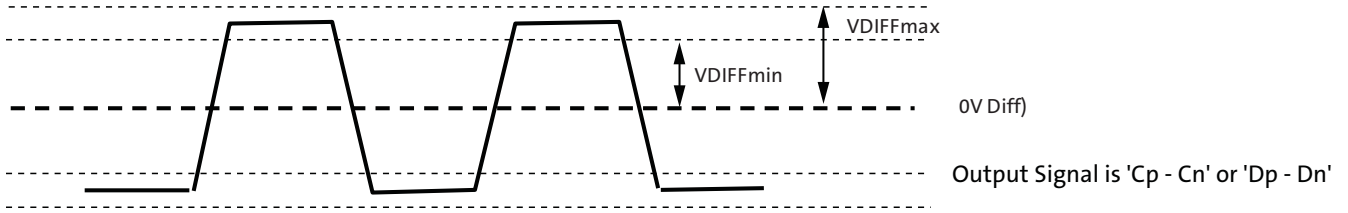

Table 16: Rise and Fall Times

Measurement Conditions: HiSPi Power Supply 0.4V, Max Freq 700 MHz

Parameter	Symbol	Min	Typ	Max	Unit
Data Rate	1/UI	280	–	700	Mb/s
Max setup time from transmitter	TxPRE	0.3	–	–	UI ¹
Max hold time from transmitter	TxPost	0.3	–	–	UI
Rise time (20% - 80%)	RISE	–	0.25UI	–	
Fall time (20% - 80%)	FALL	150ps	0.25 UI	–	
Clock duty	PLL_DUTY	45	50	55	%
Bitrate Period	t _{pw}	1.43		3.57	ns ¹
Eye Width	t _{eye}	0.3			UI ^{1,2}
Data Total jitter (pk pk)@1e-9	t _{totaljit}			0.2	UI ^{1,2}
Clock Period Jitter(RMS)	t _{ckjit}			50	ps ²
Clock cycle to cycle jitter (RMS)	t _{cyj}			100	ps ²
Clock to Data Skew	t _{chskew}	-0.1		0.1	UI ^{1,2}
PHY-to-PHY Skew	t _{PHYskew}			2.1	UI ^{1,5}
Mean diferential skew	t _{DIFFSKEW}	-100		100	ps ⁶

- Notes:
1. One UI is defined as the normalized mean time between one edge and the following edge of the clock.
 2. Taken from 0V crossing point w/ DLL off.
 3. Also defined with a maximum loading capacitance of 10pF on any pin. The loading capacitance may also need to be less for higher bitrates so the rise and fall times do not exceed the maximum 0.3UI.
 4. The absolute mean skew between the Clock lane and any Data Lane in the same PHY between any edges.
 5. The absolute mean skew between any Clock in one PHY and any Data lane in any other PHY between any edges.
 6. Differential skew is defined as the skew between complementary outputs. It is measured as the absolute time between the two complementary edges at mean V_{CM} point.

Figure 9: Eye Diagram for Clock and Data Signals

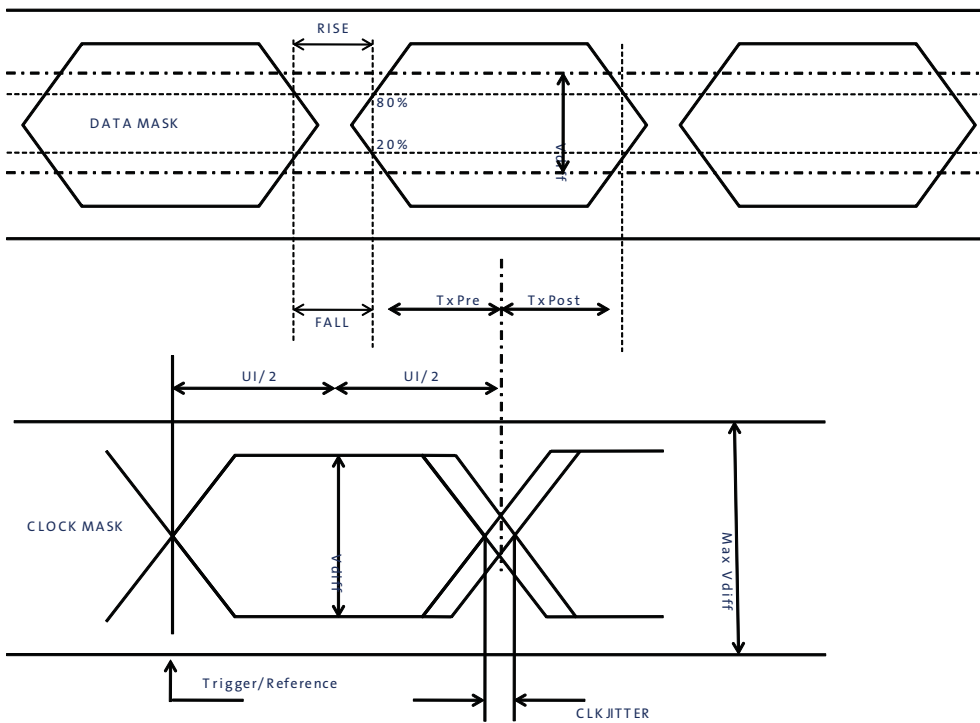
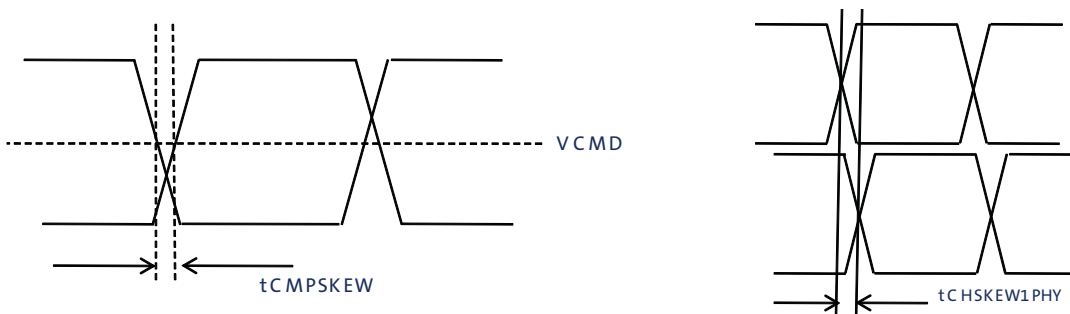

Figure 10: Skew Within the PHY and Output Channels



Power-On Reset and Standby Timing

Power-Up Sequence

The recommended power-up sequence for the MT9M021/MT9M031 is shown in Figure 11. The available power supplies (VDD_IO, VDD, VDD_SLVS, VDD_PLL, VAA, VAA_PIX) must have the separation specified below.

1. Turn on VDD_PLL power supply.
2. After 0–10µs, turn on VAA and VAA_PIX power supply.
3. After 0–10µs, turn on VDD_IO power supply.
4. After the last power supply is stable, enable EXTCLK.
5. Assert RESET_BAR for at least 1ms.
6. Wait 150000 EXTCLKs (for internal initialization into software standby).
7. Configure PLL, output, and image settings to desired values.
8. Wait 1ms for the PLL to lock.
9. Set streaming mode (R0x301a[2] = 1).

Figure 11: Power Up

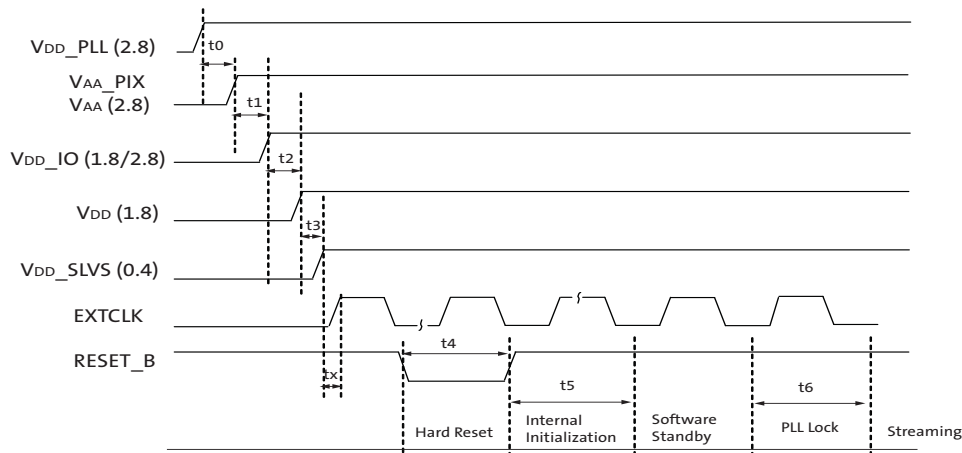

Table 17: Power-Up Sequence

Definition	Symbol	Minimum	Typical	Maximum	Unit
VDD_PLL to VAA/VAA_PIX	t0	0	10	–	µs
VAA/VAA_PIX to VDD_IO	t1	0	10	–	µs
VDD_IO to VDD	t2	0	10	–	µs
VDD to VDD_SLVS	t3	0	10	–	µs
Xtal settle time	tx	–	30 ¹	–	ms
Hard Reset	t4	1 ²	–	–	ms
Internal Initialization	t5	150000	–	–	EXTCLKs
PLL Lock Time	t6	1	–	–	ms

- Notes:
1. Xtal settling time is component-dependent, usually taking about 10 – 100 ms.
 2. Hard reset time is the minimum time required after power rails are settled. In a circuit where hard reset is held down by RC circuit, then the RC time must include the all power rail settle time and Xtal settle time.
 3. It is critical that VDD_PLL is not powered up after the other power supplies. It must be powered before or at least at the same time as the others. If the case happens that VDD_PLL is powered after

other supplies than the sensor may have functionality issues and will experience high current draw on this supply.

Power-Down Sequence

The recommended power-down sequence for the MT9M021/MT9M031 is shown in Figure 12. The available power supplies (VDD_IO, VDD, VDD_SLVS, VDD_PLL, VAA, VAA_PIX) must have the separation specified below.

1. Disable streaming if output is active by setting standby R0x301a[2] = 0
2. The soft standby state is reached after the current row or frame, depending on configuration, has ended.
3. Turn off VDD_SLVS.
4. Turn off VDD.
5. Turn off VDD_IO
6. Turn off VAA/VAA_PIX.
7. Turn off VDD_PLL.

Figure 12: Power Down

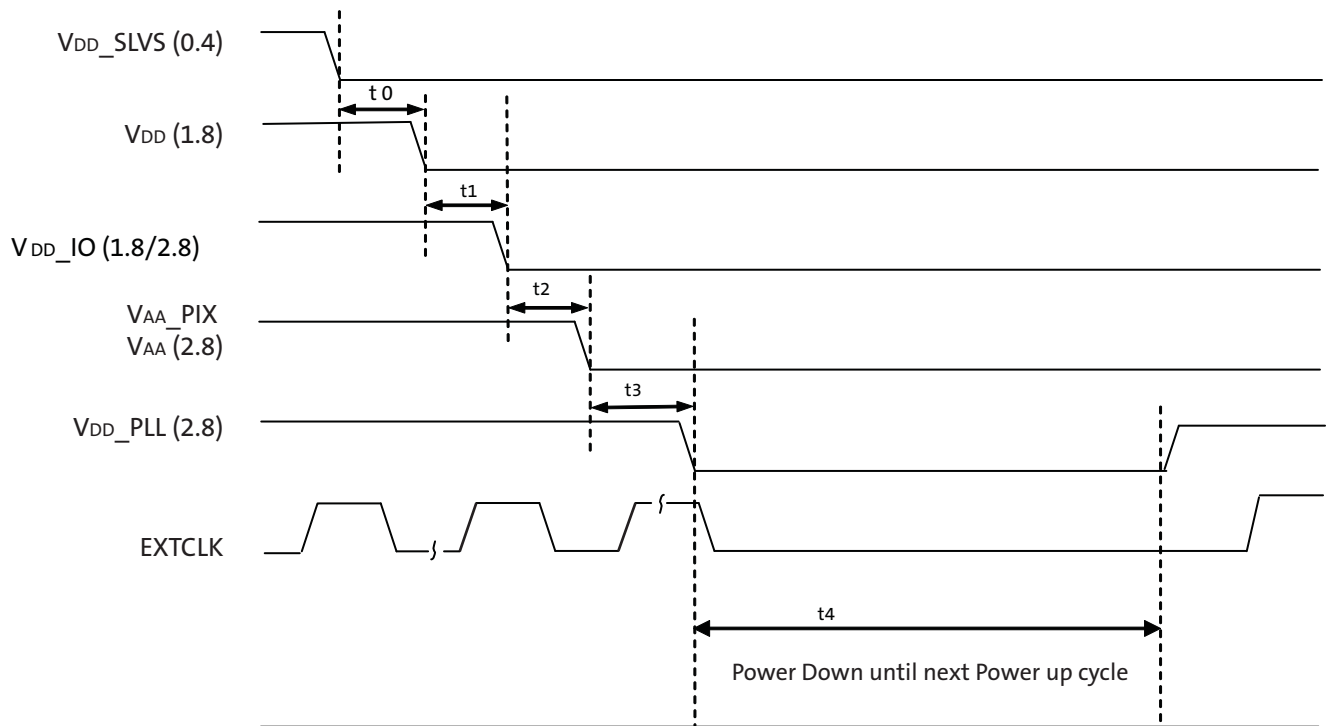

Table 18: Power-Down Sequence

Definition	Symbol	Minimum	Typical	Maximum	Unit
VDD_SLVS to VDD	t0	0	–	–	μS
VDD to VDD_IO	t1	0	–	–	μS
VDD_IO to VAA/VAA_PIX	t2	0	–	–	μS
VAA/VAA_PIX to VDD_PLL	t3	0	–	–	μS

Table 18: Power-Down Sequence

Definition	Symbol	Minimum	Typical	Maximum	Unit
PwrDn until Next PwrUp Time	t4	100	–	–	mS

Note: t4 is required between power down and next power up time; all decoupling caps from regulators must be completely discharged.

Figure 13: Quantum Efficiency – Monochrome Sensor

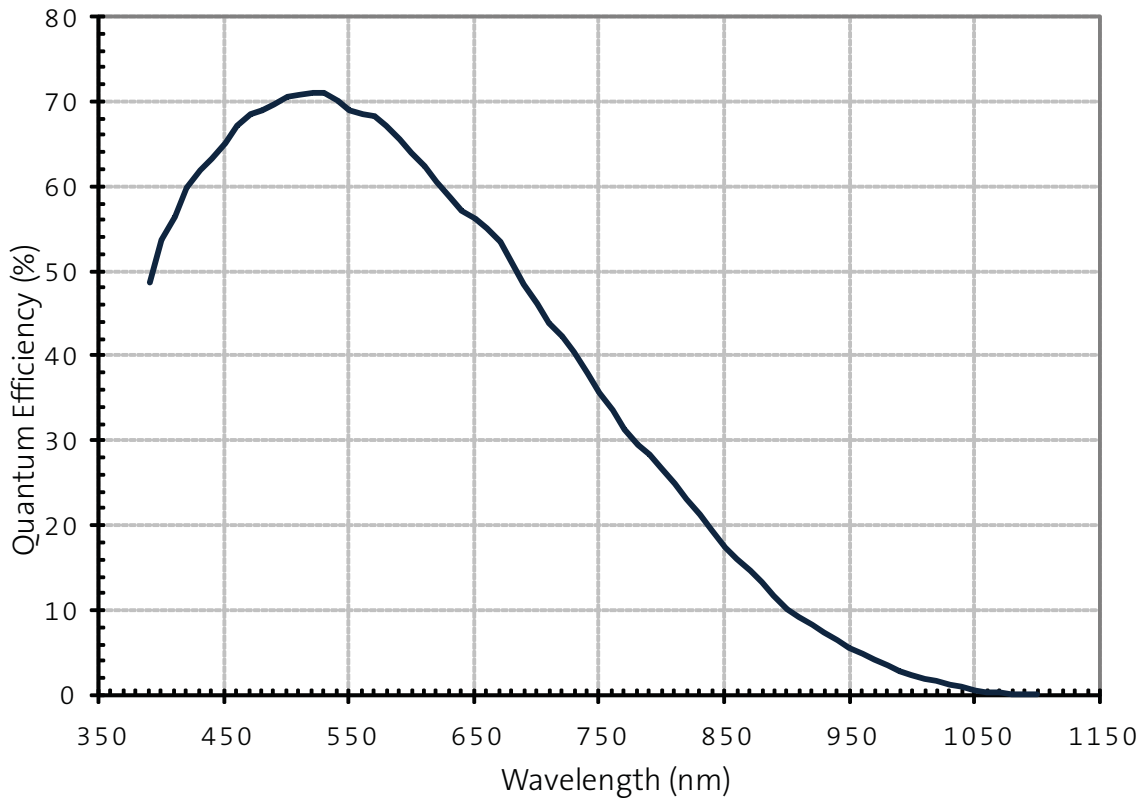
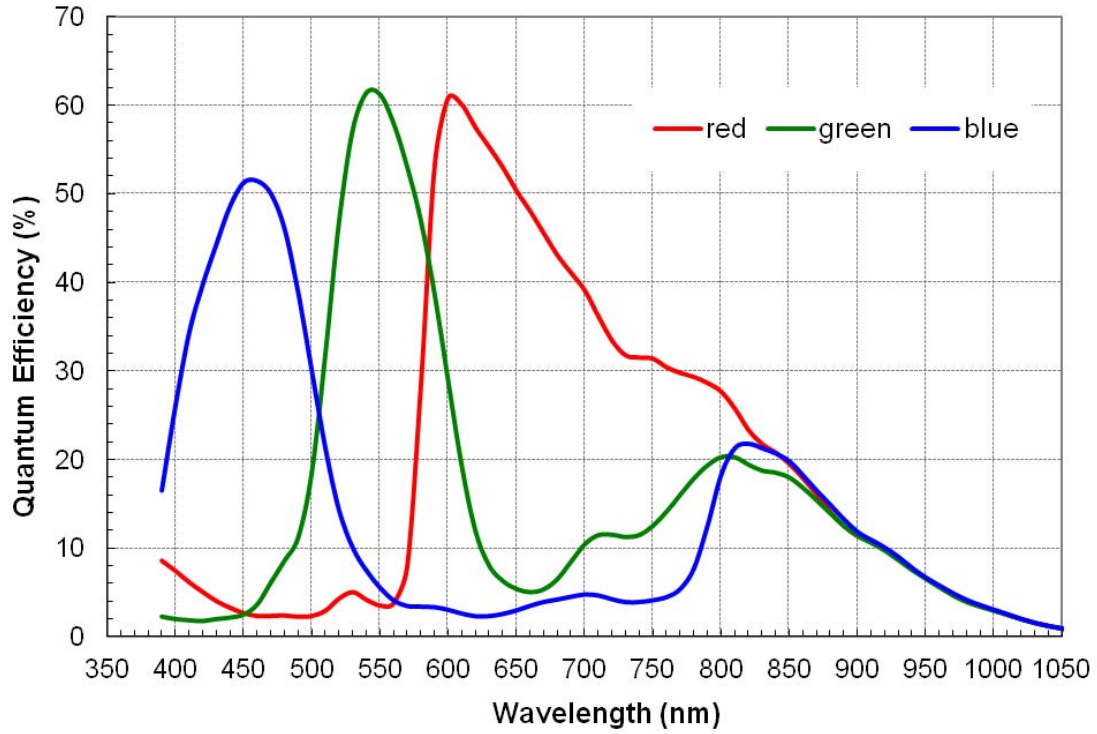
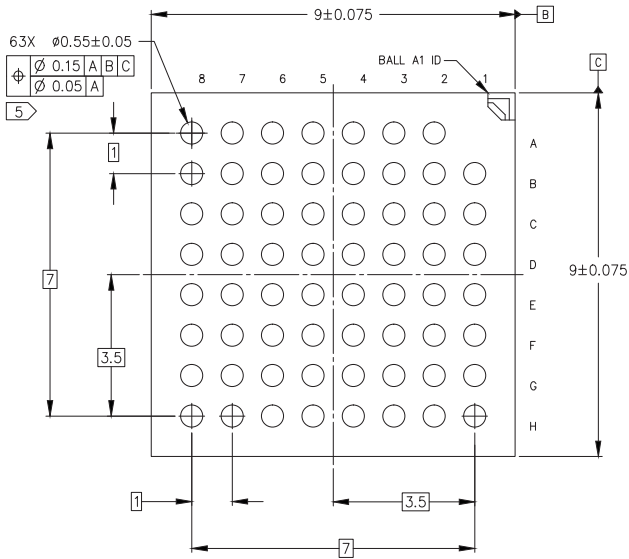
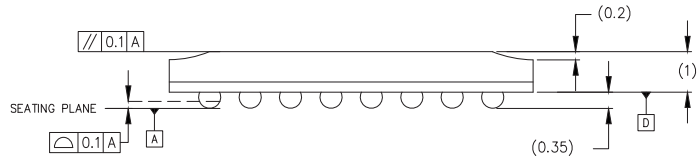

Figure 14: Quantum Efficiency – Color Sensor



Package Dimensions

Figure 15: 64-Ball iBGA Package Outline Drawing



Note: All dimensions in millimeters.

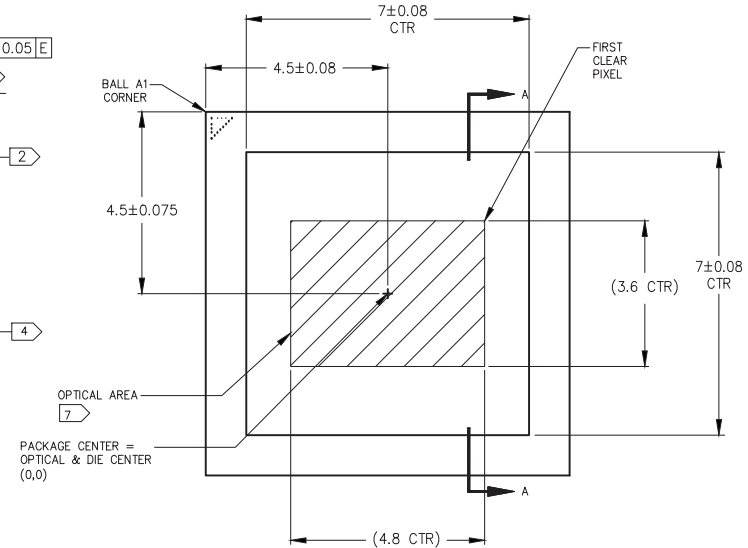
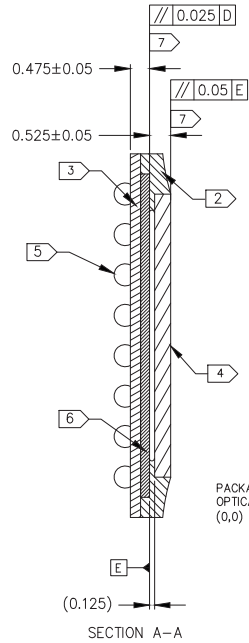

NOTES	
1	DIMENSIONS IN MM. DIMENSIONS IN () ARE FOR REFERENCE ONLY.
2	ENCAPSULANT: EPOXY.
3	SUBSTRATE MATERIAL: PLASTIC LAMINATE 0.25 THICKNESS.
4	LID MATERIAL: BOROSILICATE GLASS 0.4±0.04 THICKNESS. REFRACTIVE INDEX AT 20C° = 1.5255 @ 546nm & 1.5231 @ 588nm.
5	SOLDER BALL MATERIAL: SAC305 (96.5% Sn, 3% Ag, 0.5% Cu). DIMENSIONS APPLY TO SOLDER BALLS POST REFLOW. SOLDER BALL IS ø0.5 ON A ø0.4 SMD BALL PAD.
6	A1000 DIE: 0.2mm THICKNESS.
7	MAXIMUM ROTATION OF OPTICAL AREA RELATIVE TO PACKAGE EDGES: 1°. MAXIMUM TILT OF OPTICAL AREA RELATIVE TO SUBSTRATE PLANE [D]: 25µm. MAXIMUM TILT OF COVER GLASS RELATIVE TO OPTICAL AREA PLANE [E]: 50µm.

Figure 16: 48-pin iLCC Package Drawing

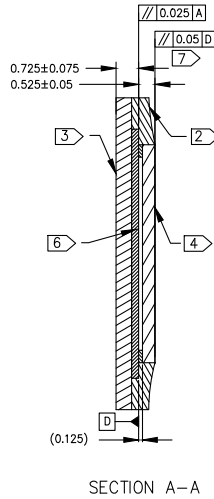
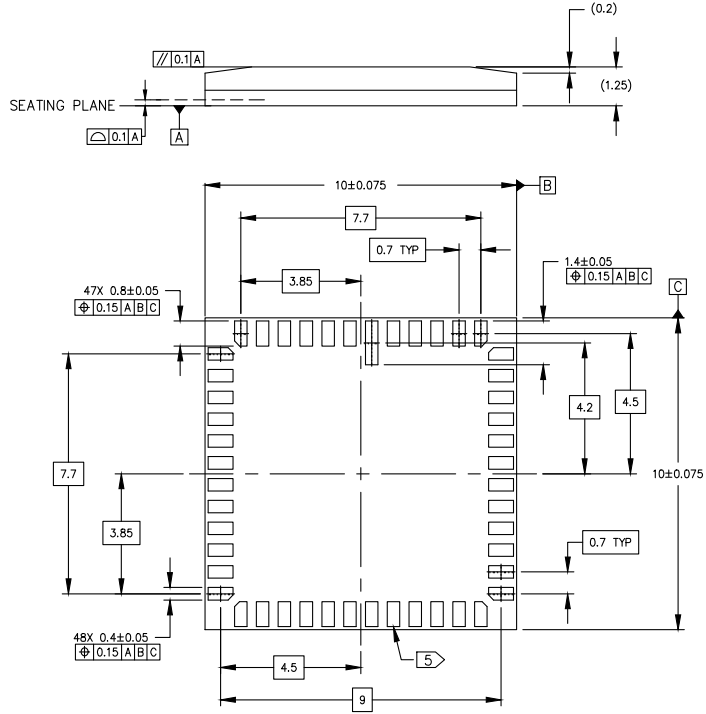

NOTES	
1	DIMENSIONS IN MM. DIMENSIONS IN () ARE FOR REFERENCE ONLY
2	ENCAPSULANT: EPOXY
3	SUBSTRATE MATERIAL: EPOXY LAMINATE 0.5 THICKNESS
4	LID MATERIAL: BOROSILICATE GLASS 0.4 THICKNESS. REFRACTIVE INDEX AT 20°C = 1.5255 @ 546nm & 1.5231 @ 588nm
5	LEAD FINISH: GOLD PLATING, 0.5 MICRONS MINIMUM THICKNESS
6	IMAGE SENSOR DIE 0.2 THICKNESS
7	MAXIMUM ROTATION OF OPTICAL AREA RELATIVE TO PACKAGE EDGES: 1° MAXIMUM TILT OF OPTICAL AREA RELATIVE TO SEATING PLANE [A]: 25 MICRONS MAXIMUM TILT OF OPTICAL AREA RELATIVE TO TOP OF COVER GLASS[D]: 50 MICRONS
8	OPTICAL CENTER = PACKAGE CENTER

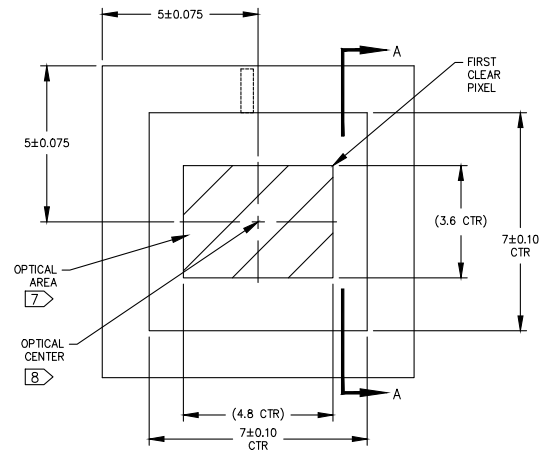

Revision History

Rev. G	4/15/15
<ul style="list-style-type: none"> • Updated “Ordering Information” on page 2 	
Rev. F	9/4/12
<ul style="list-style-type: none"> • Converted to ON Semiconductor template • Removed Confidential marking 	
Rev. E	9/4/12
<ul style="list-style-type: none"> • Updated to Production • Updated Table 1, “Key Parameters,” on page 1 • Updated Table 2, “Available Part Numbers,” on page 2 • Updated “General Description” on page 8 • Updated Figure 2: “Typical Configuration: Serial Four-Lane HiSPi Interface,” on page 10 • Updated Figure 3: “Typical Configuration: Parallel Pixel Data Interface,” on page 11 • Updated Table 5, “Two-Wire Serial Bus Characteristics,” on page 17 • Updated Figure 7: “I/O Timing Diagram,” on page 18 • Updated Table 6, “I/O Timing Characteristics1,” on page 18 • Added Table 7, I/O Rise Slew Rate (2.8V Vdd_IO)1 and Table 8, “I/O Fall Slew Rate (2.8V Vdd_IO)1,” on page 20 • Added Table 9, I/O Rise Slew Rate (1.8V Vdd_IO)1 and Table 10, “I/O Fall Slew Rate (1.8V Vdd_IO)1,” on page 20 • Updated Table 13, “Operating Current Consumption for Parallel Output,” on page 21 • Updated Table 14, “Standby Current Consumption,” on page 22 	
Rev. D	5/17/12
<ul style="list-style-type: none"> • Added MT9M031 • Updated Table 1, “Key Parameters,” on page 1 • Updated Table 2, “Available Part Numbers,” on page 2 • Updated “LV Format Options” on page 14 • Updated “HiSPi Physical Layer” on page 15 • Added Figure 5: “48 iLCC Package, Parallel Output,” on page 14 • Added Table 4, “Pin Descriptions - 48 iLCC Package, Parallel,” on page 15 • Updated Figure 7: “I/O Timing Diagram,” on page 18 • Updated Table 6, “I/O Timing Characteristics1,” on page 18 • Updated “HiSPi Electrical Specifications” on page 22 • Added Table 15, “Input Voltage and Current (HiSPi Power Supply 0.4 V),” on page 22 • Added Figure 8: “Differential Output Voltage for Clock or Data Pairs,” on page 23 • Added Table 16, “Rise and Fall Times,” on page 23 • Added Figure 9: “Eye Diagram for Clock and Data Signals,” on page 24 • Added Figure 10: “Skew Within the PHY and Output Channels,” on page 24 • Added Figure 16: “48-pin iLCC Package Drawing,” on page 31 • Deleted the following major sections and their sub-sections. Refer to the Developer Guide: <ul style="list-style-type: none"> – Pixel Data Format – Output Data Format – Two-Wire Serial Register Interface 	

- Real-Time Context Switching
- Replaced “Feature Description” with “Functional Overview” on page 8 and “Features Overview” on page 9

Rev. C6/14/11

- Updated to Preliminary
- Updated operating temperature in Table 1, “Key Parameters,” on page 1 and in “General Description” on page 8
- Updated Figure 6: “Two-Wire Serial Bus Timing Parameters,” on page 16
- Updated Table 5, “Two-Wire Serial Bus Characteristics,” on page 17
- Updated Figure 7: “I/O Timing Diagram,” on page 18
- Added Table 6, “I/O Timing Characteristics1,” on page 18
- Updated Table 6, “DC Electrical Characteristics,” on page 14
- Replaced Table 10, Power Consumption with Table 13, “Operating Current Consumption for Parallel Output,” on page 21
- Added Table 14, “Standby Current Consumption,” on page 22
- Updated Table 14, Power Supply and Operating Temperatures
- Deleted Table 14, “Input Voltage and Current,” on page 39
- Added Table 15, “SLVS Electrical DC Specification,” on page 40
- Updated Table 16, “SLVS Electrical Timing Specification,” on page 40
- Updated Table 17, “Power-Up Sequence,” on page 25
- Updated Figure 13: “Quantum Efficiency – Monochrome Sensor,” on page 28

Rev. B11/16/09

- Updated the following parameters in Table 1, “Key Parameters,” on page 1
 - input clock range
 - responsivity
 - dynamic range
- Updated Table 2, “Available Part Numbers,” on page 2
- Replaced “scaling” with “digital binning” in third paragraph of “General Description” on page 8
- Updated master clock range in Figure 2 on page 10 and Figure 3 on page 11
- Updated number of rows in first sentence of first paragraph in “Pixel Array Structure” on page 10
- Updated array pixel coordinates in Figure 6 on page 12
- Added “Default Readout Order” on page 12
- Updated “Output Data Format” on page 13
- Added “Readout Sequence” on page 13
- Replaced “Parallel Data Timing” section with “Parallel Output Data Timing” on page 14
- Moved Figure 13, Line Timing and FRAME_VALID/LINE_VALID Signals and Table 5, Frame Time: Long Integration Time to new section “Frame Time” on page 17; added Table 4, “Frame Time (Example Based on 1280 x 960, 45 Frames Per Second),” on page 17
- Updated first paragraph of “Real-Time Context Switching” on page 19
- Updated Table 6, “Real-Time Context-Switchable Registers,” on page 19
- Updated “Features” section as follows:
 - Updated “Trigger Mode” on page 20
 - Moved “Hard Reset of Logic” and Soft Reset of Logic” to “Reset” on page 21

- Added “Readout Modes” on page 25; “Mirror” on page 27, “Maintaining a Constant Frame Rate” on page 28, “Synchronizing Register Writes to Frame Boundaries” on page 28; “Restart” on page 29, “Automatic Exposure Control” on page 29, and “Test Patterns” on page 32
- Deleted “Pixel Integration Control,” “Pixel Clock Speed,” “Statistics and Settings Readout,” “Read Mode Options,” and “Line_Valid”
- Updated “Electrical Specifications” on page 16
- Moved “Power-On Reset and Standby Timing” on page 25 from appendix to main body of document
- Replaced Figure 13: “Quantum Efficiency – Monochrome Sensor,” on page 28 with placeholder
- Updated Figure 15: “64-Ball iBGA Package Outline Drawing,” on page 30

Rev. A2/18/09

- Initial release

ON Semiconductor and the ON logo are registered trademarks of Semiconductor Components Industries, LLC (SCILLC) or its subsidiaries in the United States and/or other countries. SCILLC owns the rights to a number of patents, trademarks, copyrights, trade secrets, and other intellectual property. A listing of SCILLC's product/patent coverage may be accessed at www.onsemi.com/site/pdf/Patent-Marking.pdf. SCILLC reserves the right to make changes without further notice to any products herein. SCILLC makes no warranty, representation or guarantee regarding the suitability of its products for any particular purpose, nor does SCILLC assume any liability arising out of the application or use of any product or circuit, and specifically disclaims any and all liability, including without limitation special, consequential or incidental damages. "Typical" parameters which may be provided in SCILLC data sheets and/or specifications can and do vary in different applications and actual performance may vary over time. All operating parameters, including "Typicals" must be validated for each customer application by customer's technical experts. SCILLC does not convey any license under its patent rights nor the rights of others. SCILLC products are not designed, intended, or authorized for use as components in systems intended for surgical implant into the body, or other applications intended to support or sustain life, or for any other application in which the failure of the SCILLC product could create a situation where personal injury or death may occur. Should Buyer purchase or use SCILLC products for any such unintended or unauthorized application, Buyer shall indemnify and hold SCILLC and its officers, employees, subsidiaries, affiliates, and distributors harmless against all claims, costs, damages, and expenses, and reasonable attorney fees arising out of, directly or indirectly, any claim of personal injury or death associated with such unintended or unauthorized use, even if such claim alleges that SCILLC was negligent regarding the design or manufacture of the part. SCILLC is an Equal Opportunity/Affirmative Action Employer. This literature is subject to all applicable copyright laws and is not for resale in any manner.



Стандарт Электрон Связь

Мы молодая и активно развивающаяся компания в области поставок электронных компонентов. Мы поставляем электронные компоненты отечественного и импортного производства напрямую от производителей и с крупнейших складов мира.

Благодаря сотрудничеству с мировыми поставщиками мы осуществляем комплексные и плановые поставки широчайшего спектра электронных компонентов.

Собственная эффективная логистика и склад в обеспечивает надежную поставку продукции в точно указанные сроки по всей России.

Мы осуществляем техническую поддержку нашим клиентам и предпродажную проверку качества продукции. На все поставляемые продукты мы предоставляем гарантию .

Осуществляем поставки продукции под контролем ВП МО РФ на предприятия военно-промышленного комплекса России , а также работаем в рамках 275 ФЗ с открытием отдельных счетов в уполномоченном банке. Система менеджмента качества компании соответствует требованиям ГОСТ ISO 9001.

Минимальные сроки поставки, гибкие цены, неограниченный ассортимент и индивидуальный подход к клиентам являются основой для выстраивания долгосрочного и эффективного сотрудничества с предприятиями радиоэлектронной промышленности, предприятиями ВПК и научно-исследовательскими институтами России.

С нами вы становитесь еще успешнее!

Наши контакты:

Телефон: +7 812 627 14 35

Электронная почта: sales@st-electron.ru

Адрес: 198099, Санкт-Петербург,
Промышленная ул, дом № 19, литера Н,
помещение 100-Н Офис 331