

## 5GHz Band SPDT Switch + LNA GaAs MMIC

### ■ GENERAL DESCRIPTION

The NJG1739K51 is a 5GHz band SPDT switch + low noise amplifier GaAs MMIC designed for wireless LAN front-end applications.

The NJG1739K51 features low current consumption, low insertion loss of transmit path and low noise figure of RX LNA mode.

The NJG1739K51 has ESD protection devices to achieve excellent ESD performances.

A small and ultra-thin package of QFN12-51 is adopted.

### ■ PACKAGE OUTLINE

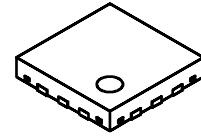

NJG1739K51

### ■ APPLICATIONS

5GHz Band WLAN front-end application

### ■ FEATURES

- Operating voltage  $V_{DD}=3.6V$  typ.
- Operating frequency freq=4900 to 5900MHz

#### [ RX LNA mode ]

- Operating current 8mA typ. @ $V_{DD}=3.6V$ ,  $V_{CTL1}=V_{CTL3}=3.3V$ ,  $V_{CTL2}=0V$
- Small signal gain 12.0dB typ.
- Noise figure 2.5dB typ.
- Input power 1dB compression 0dBm typ.

#### [ RX Bypass mode ]

- Operating current 4 $\mu$ A typ. @ $V_{DD}=3.6V$ ,  $V_{CTL1}=3.3V$ ,  $V_{CTL2}=V_{CTL3}=0V$
- Insertion loss 8.5dB typ.
- Input power 1dB compression +15dBm typ.

#### [ TX mode ]

- Insertion loss 0.5dB typ.
- Input power 0.1dB compression +29dBm typ.

- Package QFN12-51 (Package size: 2.0mm x 2.0mm x 0.375mm typ.)
- RoHS compliant and Halogen Free, MSL1

### ■ PIN CONFIGURATION

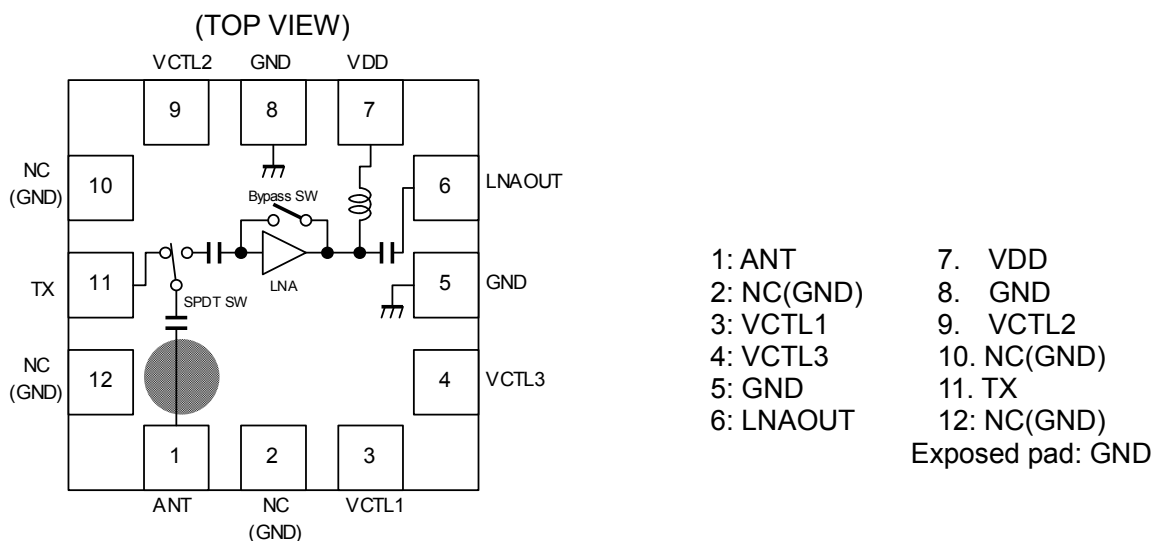

Note: Specifications and description listed in this datasheet are subject to change without notice.

■ TRUTH TABLE

“H”=V<sub>CTL</sub>(H), “L”=V<sub>CTL</sub>(L)

mode	VCTL1 (SW RX)	VCTL2 (SW TX)	VCTL3 (LNA)	STATE				
				IDD	LNA	Bypass	RX SW	TX SW
RX LNA	H	L	H	I <sub>DD1</sub>	ON	OFF	ON	OFF
RX Bypass	H	L	L	I <sub>DD2</sub>	OFF	ON	ON	OFF
TX	L	H	L	I <sub>DD2</sub>	OFF	ON	OFF	ON
Sleep	L	L	L	I <sub>DD3</sub>	OFF	OFF	OFF	OFF

## ■ ABSOLUTE MAXIMUM RATINGS

$T_a=+25^{\circ}\text{C}$

PARAMETERS	SYMBOL	CONDITIONS	RATINGS	UNITS
Supply voltage	$V_{DD}$		5.5	V
Control voltage	$V_{CTL}$		5.5	V
Input power 1	$P_{IN1}$	ANT terminal, $V_{DD}=3.6\text{V}$ , $V_{CTL1}=V_{CTL3}=3.3\text{V}$ , $V_{CTL2}=0\text{V}$	+15	dBm
Input power 2	$P_{IN2}$	TX terminal, $V_{DD}=3.6\text{V}$ , $V_{CTL1}=V_{CTL3}=0\text{V}$ , $V_{CTL2}=3.3\text{V}$	+25	dBm
Power dissipation	$P_D$	Four-layer FR4 PCB with through-hole (101.5x114.5mm), $T_j=150^{\circ}\text{C}$	1190	mW
Operation temperature	$T_{opr}$		-40 to +85	$^{\circ}\text{C}$
Storage temperature	$T_{stg}$		-55 to +150	$^{\circ}\text{C}$

## ■ ELECTRICAL CHARACTERISTICS 1 (DC Characteristics)

$V_{DD}=3.6\text{V}$ ,  $V_{CTL(H)}=3.3\text{V}$ ,  $V_{CTL(L)}=0\text{V}$ ,  $T_a=+25^{\circ}\text{C}$ ,  $Z_s=Z_l=50\Omega$

PARAMETERS	SYMBOL	CONDITIONS	MIN	TYP	MAX	UNITS
Supply voltage	$V_{DD}$		3.0	3.6	5.0	V
Control voltage 1(High)	$V_{CTL1(H)}$		2.8	3.3	5.0	V
Control voltage 2(High)	$V_{CTL2(H)}$		2.8	3.3	5.0	V
Control voltage 3(High)	$V_{CTL3(H)}$		2.8	3.3	5.0	V
Control voltage 1(Low)	$V_{CTL1(L)}$		0.0	-	0.4	V
Control voltage 2(Low)	$V_{CTL2(L)}$		0.0	-	0.4	V
Control voltage 3(Low)	$V_{CTL3(L)}$		0.0	-	0.4	V
LNA operating current 1 (RX LNA mode)	$I_{DD1}$	RF OFF, $V_{CTL1}=V_{CTL3}=3.3\text{V}$ , $V_{CTL2}=0\text{V}$	-	8	13	mA
LNA operating current 2 (RX Bypass mode)	$I_{DD2}$	RF OFF, $V_{CTL1}=3.3\text{V}$ , $V_{CTL2}=V_{CTL3}=0\text{V}$	-	4	12	$\mu\text{A}$
LNA operating current 3 (Sleep mode)	$I_{DD3}$	RF OFF, $V_{CTL1}=V_{CTL2}=V_{CTL3}=0.4\text{V}$	-	4	12	$\mu\text{A}$
LNA operating current 4 (VCTL OPEN)	$I_{DD4}$	RF OFF, $V_{CTL1}=V_{CTL2}=V_{CTL3}=\text{open}$	-	4	12	$\mu\text{A}$
Control current 1	$I_{CTL1}$	RF OFF, $V_{CTL1}=3.3\text{V}$ , $V_{CTL2}=V_{CTL3}=0\text{V}$	-	5	20	$\mu\text{A}$
Control current 2	$I_{CTL2}$	RF OFF, $V_{CTL2}=3.3\text{V}$ , $V_{CTL1}=V_{CTL3}=0\text{V}$	-	5	20	$\mu\text{A}$
Control current 3	$I_{CTL3}$	RF OFF, $V_{CTL3}=3.3\text{V}$ , $V_{CTL1}=V_{CTL2}=0\text{V}$	-	5	20	$\mu\text{A}$

## ■ ELECTRICAL CHARACTERISTICS 2 (RF Characteristics: RX LNA mode, LNA+SPDT SW)

$V_{DD}=3.6V$ ,  $V_{CTL1}=V_{CTL3}=3.3V$ ,  $V_{CTL2}=0V$ ,  $freq=4900$  to  $5900MHz$ ,  
 $T_a=+25^{\circ}C$ ,  $Z_s=Z_l=50\Omega$ , with application circuit

PARAMETERS	SYMBOL	CONDITIONS	MIN	TYP	MAX	UNITS
Small signal gain 1	Gain1	Exclude PCB and connector losses*1	9.0	12.0	14.0	dB
Gain flatness 1	Gflat1	f=4900 to 4980MHz, f=5400 to 5480MHz, f=5820 to 5900MHz	-	-	0.3	dB
Isolation 1	ISL1		-	30	-	dB
Noise figure 1	NF1	Exclude PCB and connector losses*2	-	2.5	3.0	dB
Input power at 1dB compression 1	$P_{-1dB(IN)1}$		-	0	-	dBm
Input 3rd order Intercept point 1	IIP3_1	f1=freq, f2=freq+100kHz, $P_{IN}=-18dBm$	-	+9	-	dBm
Outband input 3rd order Intercept point 1	IIP3_OB1	f1=2450MHz, f2=f1+100kHz, $P_{IN}=-18dBm$	-	+2	-	dBm
ANT port return loss 1	RLi1		-	8.0	-	dB
LNAOUT port return loss 1	RLo1		-	9.0	-	dB
LNA switching time	Tsw1_1	10% $V_{CTL}$ to 90% RF	-	250	400	ns
Other switching time	Tsw2_1	10% $V_{CTL}$ to 90% RF	-	200	500	ns

\*1) 0.64dB(4900MHz), 0.71dB(5400MHz), 0.79dB(5900MHz)

\*2) 0.32dB(4900MHz), 0.35dB(5400MHz), 0.39dB(5900MHz)

## ■ ELECTRICAL CHARACTERISTICS 3 (RF Characteristics: RX Bypass mode, Bypass SW+SPDT SW)

$V_{DD}=3.6V$ ,  $V_{CTL1}=3.3V$ ,  $V_{CTL2}=V_{CTL3}=0V$ ,  $freq=4900$  to  $5900MHz$ ,  
 $T_a=+25^{\circ}C$ ,  $Z_s=Z_l=50\Omega$ , with application circuit

PARAMETERS	SYMBOL	CONDITIONS	MIN	TYP	MAX	UNITS
Insertion loss 2	LOSS2	Exclude PCB and connector losses*3	6.0	8.5	10.5	dB
Input power at 1dB compression 2	$P_{-1dB(IN)2}$		-	+15	-	dBm
Input 3rd order Intercept point 2	IIP3_2	f1=freq, f2=freq+100kHz, $P_{IN}=-10dBm$	-	+14	-	dBm
ANT port return loss 2	RLi2		-	7.0	-	dB
LNAOUT port return loss 2	RLo2		-	12.0	-	dB

\*3) 0.64dB(4900MHz), 0.71dB(5400MHz), 0.79dB(5900MHz)

■ **ELECTRICAL CHARACTERISTICS 4** (RF Characteristics: TX mode, SPDT SW)

$V_{DD}=3.6V$ ,  $V_{CTL1}=V_{CTL3}=0V$ ,  $V_{CTL2}=3.3V$ , freq=4900 to 5900MHz,  
 $T_a=+25^{\circ}C$ ,  $Z_s=Z_l=50\Omega$ , with application circuit

PARAMETERS	SYMBOL	CONDITIONS	MIN	TYP	MAX	UNITS
Insertion loss 3	LOSS3	$P_{IN}=+23dBm$ , Exclude PCB and connector losses*4	-	0.5	0.8	dB
Input power at 0.1dB compression 3	$P_{-0.1dB(IN)3}$		-	+29	-	dBm
ANT port return loss 3	RLi3		-	16	-	dB
TX port return loss 3	RLo3		-	20	-	dB

\*4) 0.65dB(4900MHz), 0.73dB(5400MHz), 0.81dB(5900MHz)

## ■ TERMINAL INFORMATION

Pin No.	SYMBOL	DESCRIPTION
1	ANT	RF transmitting/receiving terminal. No DC blocking capacitor is required for this port because of internal capacitor.
2	NC(GND)	No connected terminal. This terminal is not connected with internal circuit. Please connect to the PCB ground plane.
3	VCTL1	Control signal input terminal. This terminal is set to High-Level (+2.8 to +5.0V) or Low-Level (0 to +0.4V).
4	VCTL3	Control signal input terminal. This terminal is set to High-Level (+2.8 to +5.0V) or Low-Level (0 to +0.4V).
5	GND	Ground terminal. Please connect this terminal with ground plane as close as possible for excellent RF performance.
6	LNAOUT	RF receiving signal output terminal. No DC blocking capacitor is required for this port because of internal output matching circuit including DC blocking capacitor.
7	VDD	Positive voltage supply terminal. The positive voltage (+3.0 to +5.0V) has to be supplied. Please connect a bypass capacitor with GND terminal for excellent RF performance.
8	GND	Ground terminal. Please connect this terminal with ground plane as close as possible for excellent RF performance.
9	VCTL2	Control signal input terminal. This terminal is set to High-Level (+2.8 to +5.0V) or Low-Level (0 to +0.4V).
10	NC(GND)	No connected terminal. This terminal is not connected with internal circuit. Please connect to the PCB ground plane.
11	TX	RF transmitting signal input terminal. DC blocking capacitor is required for this port.
12	NC(GND)	No connected terminal. This terminal is not connected with internal circuit. Please connect to the PCB ground plane.
Exposed Pad	GND	Ground terminal. Please connect this terminal with ground plane as close as possible for excellent RF performance, and through holes for GND should be placed near by the pin connection

## ■ ELECTRICAL CHARACTERISTICS (RX LNA mode)

$V_{DD}=3.6V$ ,  $V_{CTL1}=V_{CTL3}=3.3V$ ,  $V_{CTL2}=0V$ ,  $T_a=+25^{\circ}C$ ,  $Z_s=Z_l=50\Omega$

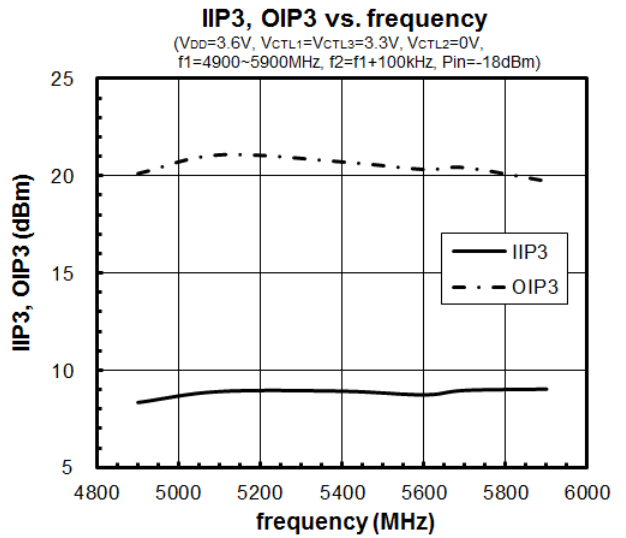
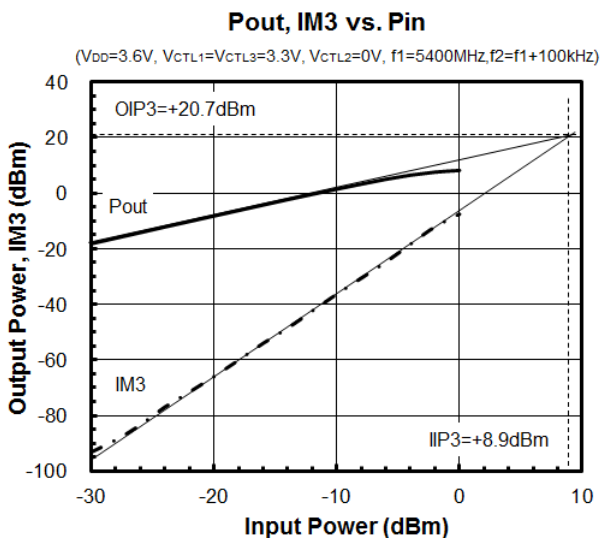
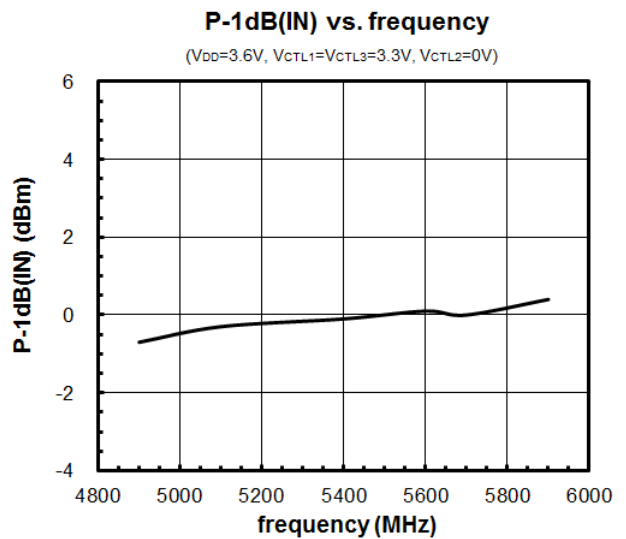
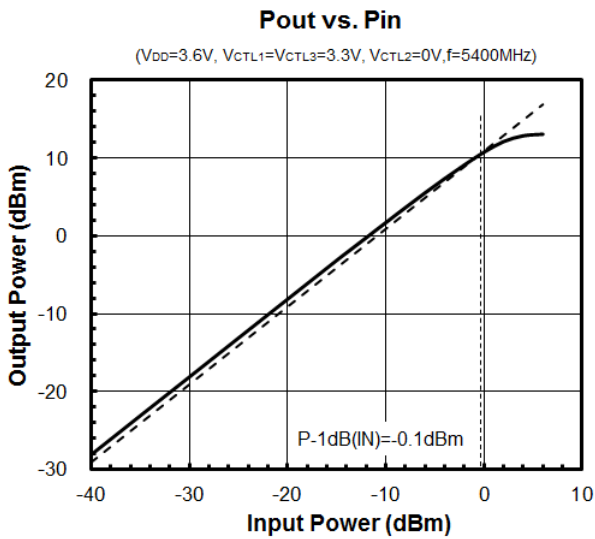
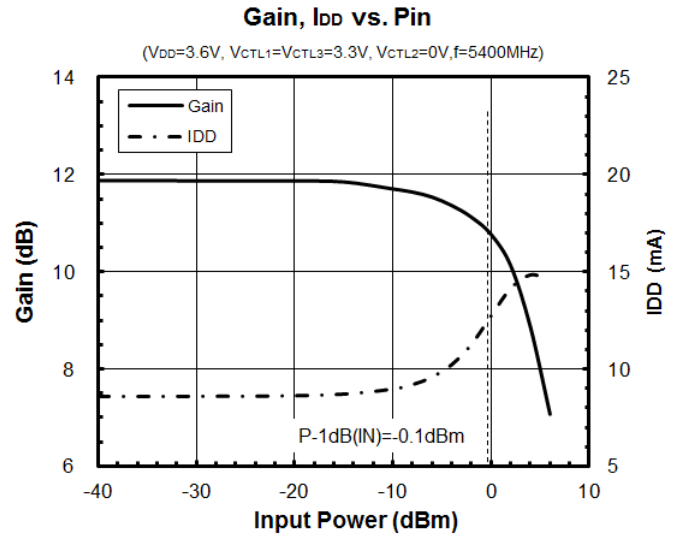
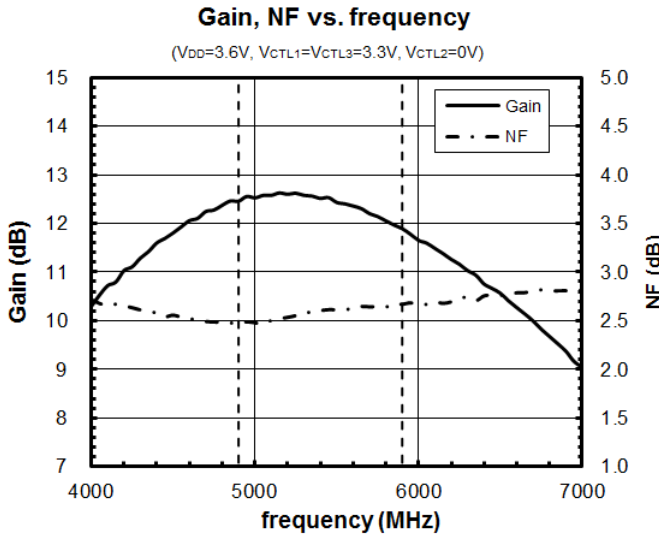

## ELECTRICAL CHARACTERISTICS (RX LNA mode)

$V_{DD}=3.6V$ ,  $V_{CTL1}=V_{CTL3}=3.3V$ ,  $V_{CTL2}=0V$ ,  $T_a=+25^{\circ}C$ ,  $Z_s=Z_l=50\Omega$

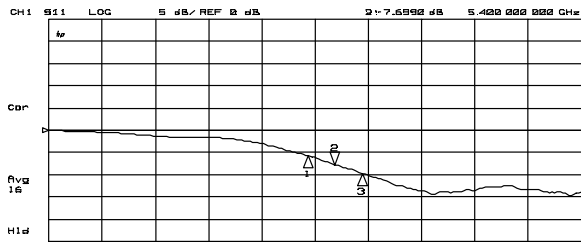

CHI Markers  
1: -1.57448 dB  
4.90000 GHz  
3: -9.60000 dB  
5.90000 GHz  
2: -7.60000 dB  
6.90000 GHz

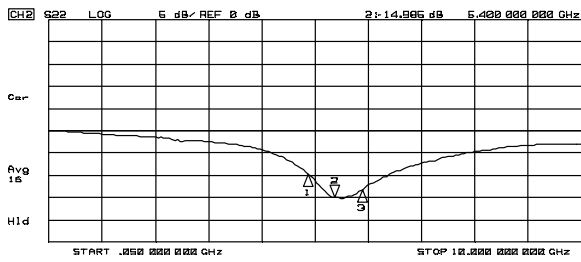

CHI Markers  
1: -9.70400 dB  
4.90000 GHz  
3: -13.21000 dB  
5.90000 GHz  
2: -11.40000 dB  
6.90000 GHz

S11, S22 (f=50MHz to 10GHz)

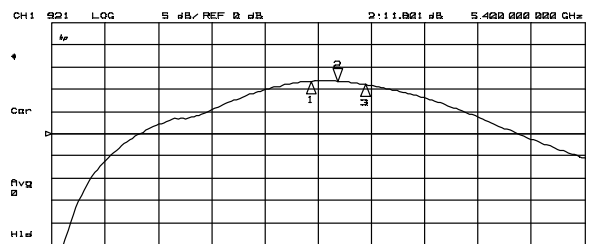

CHI Markers  
1: 1.10000 dB  
4.90000 GHz  
3: 11.10000 dB  
5.90000 GHz  
2: 11.80000 dB  
6.90000 GHz

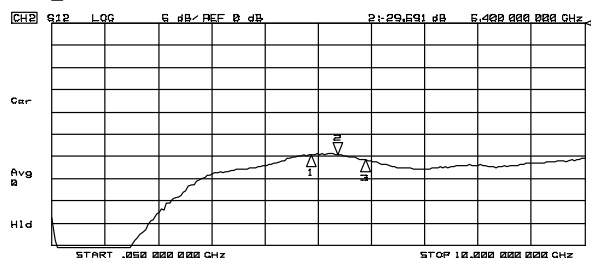

CHI Markers  
1: 29.55500 dB  
4.90000 GHz  
3: 30.70000 dB  
5.90000 GHz  
2: 30.70000 dB  
6.90000 GHz

S21, S12 (f=50MHz to 10GHz)

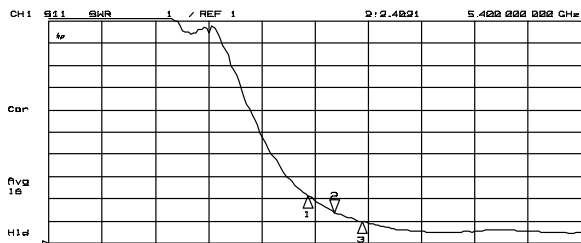

CHI Markers  
1: 1.31336 dB  
4.90000 GHz  
3: 1.99001 dB  
5.90000 GHz  
2: 1.99001 dB  
6.90000 GHz

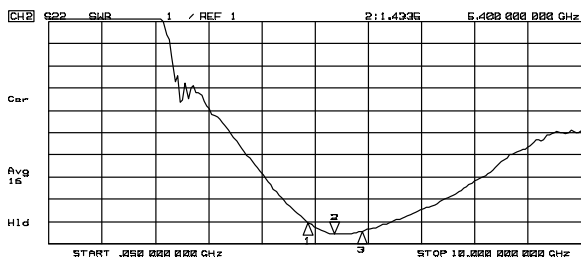

CHI Markers  
1: 1.10676 dB  
4.90000 GHz  
3: 1.65993 dB  
5.90000 GHz  
2: 1.65993 dB  
6.90000 GHz

VSWRi, VSWRo (f=50MHz to 10GHz)

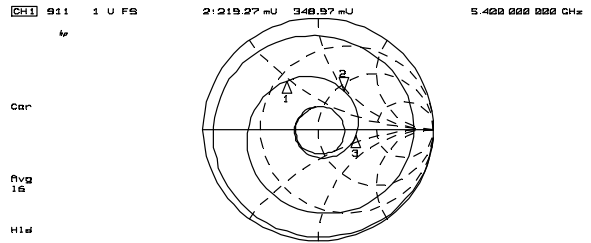

CHI Markers  
1: 275.42 mU  
4.90000 GHz  
3: 327.12 mU  
5.90000 GHz  
2: 327.12 mU  
6.90000 GHz

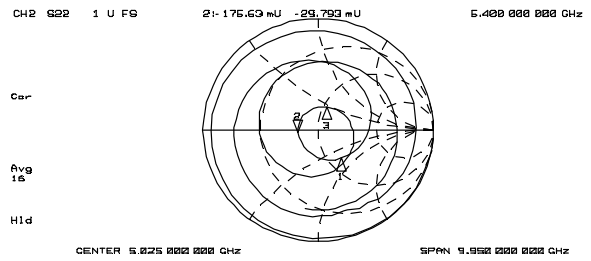

CHI Markers  
1: 198.96 mU  
4.90000 GHz  
3: 277.06 mU  
5.90000 GHz  
2: 277.06 mU  
6.90000 GHz

Zin, Zout (f=50MHz to 10GHz)



## ELECTRICAL CHARACTERISTICS (RX LNA mode)

$V_{DD}=3.6V$ ,  $V_{CTL1}=V_{CTL3}=3.3V$ ,  $V_{CTL2}=0V$ ,  $T_a=+25^\circ C$ ,  $Z_s=Z_l=50\Omega$

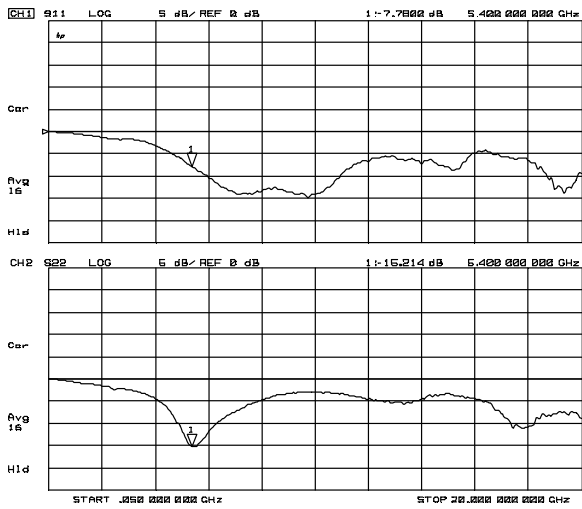

S11, S22 (f=50MHz to 20GHz)

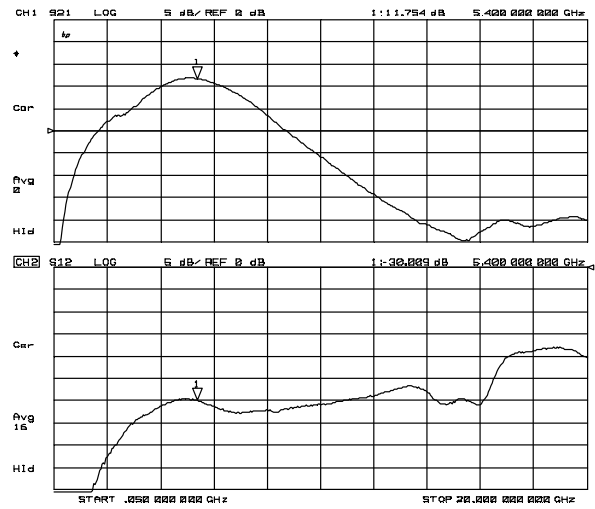

S21, S12 (f=50MHz to 20GHz)

## ELECTRICAL CHARACTERISTICS (RX LNA mode)

$V_{CTL1}=V_{CTL3}=3.3V$ ,  $V_{CTL2}=0V$ ,  $Z_s=Z_l=50\Omega$

### k factor vs. frequency

( $V_{DD}=3.6V$ ,  $V_{CTL1}=V_{CTL3}=3.3V$ ,  $V_{CTL2}=0V$ )

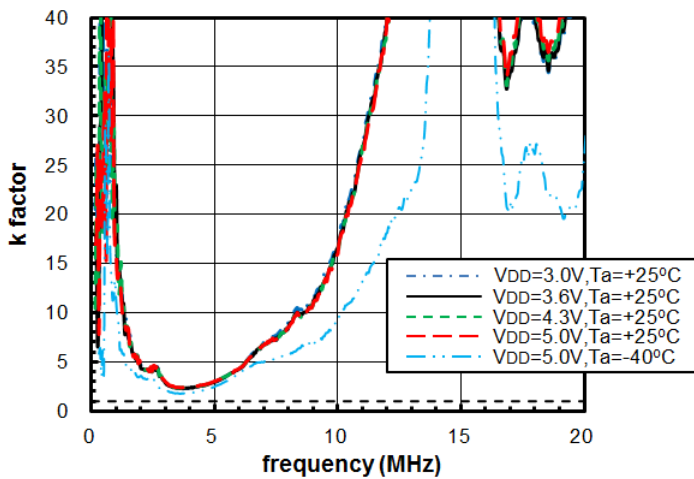

## ■ ELECTRICAL CHARACTERISTICS (RX LNA mode)

$V_{CTL1}=V_{CTL3}=3.3V, V_{CTL2}=0V, Z_s=Z_i=50\Omega$

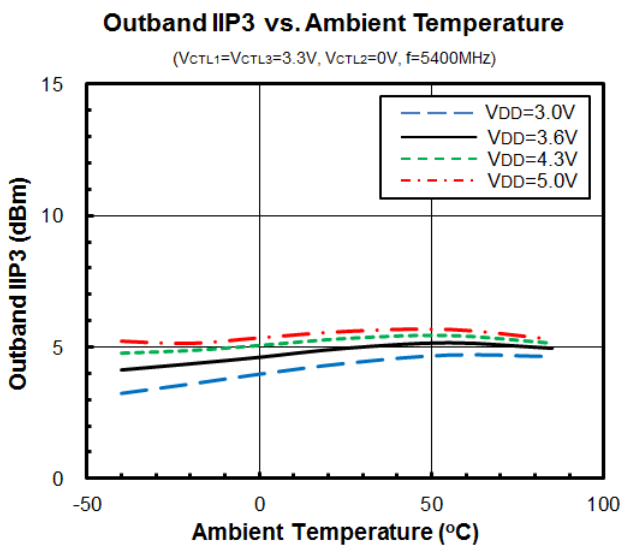
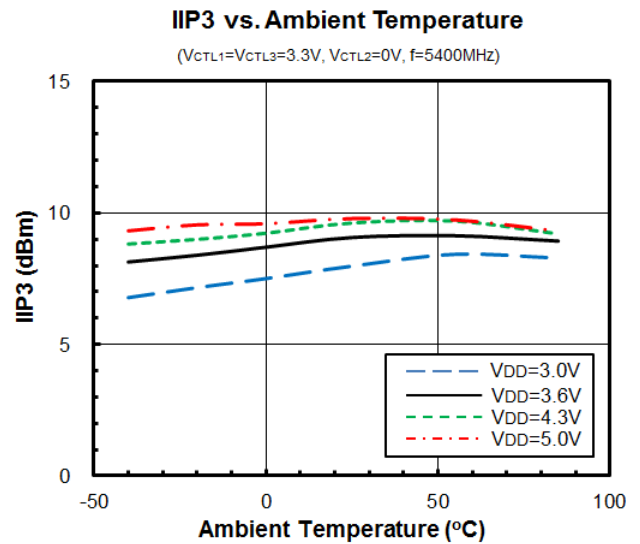
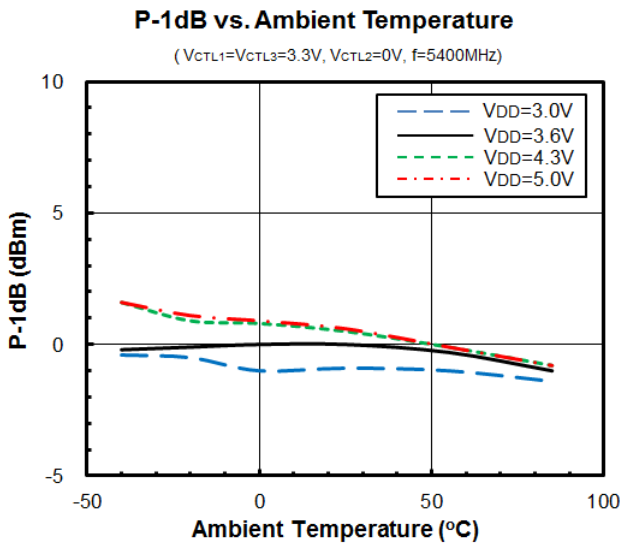
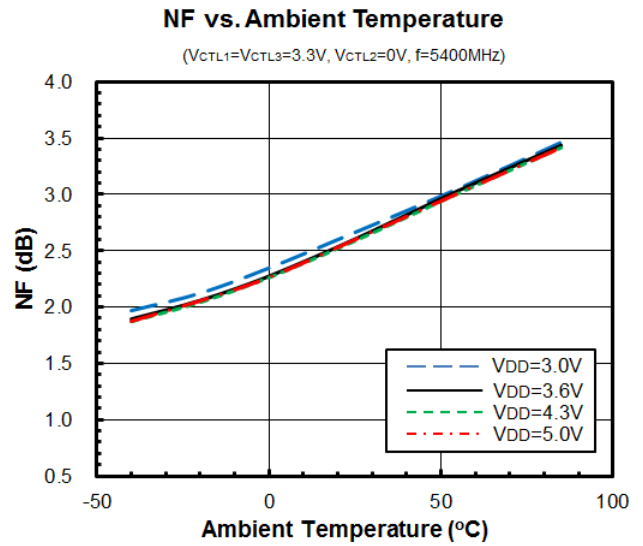
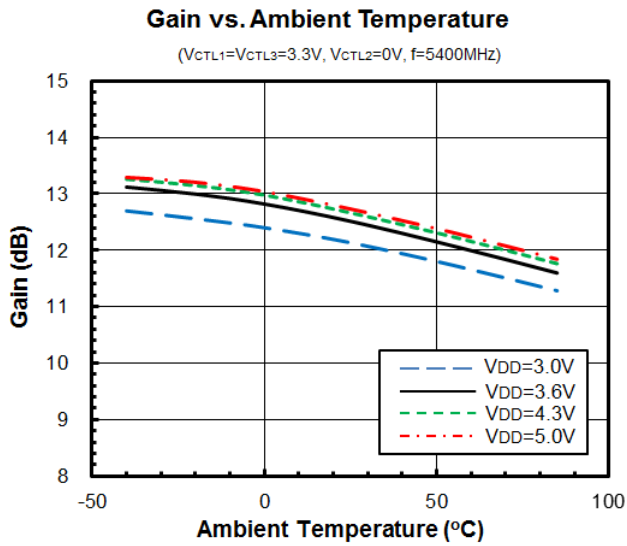

## ■ ELECTRICAL CHARACTERISTICS (RX LNA mode)

$V_{CTL1}=V_{CTL3}=3.3V$ ,  $V_{CTL2}=0V$ ,  $Z_s=Z_l=50\Omega$

**ANT Port Return Loss vs. Ambient Temperature**

( $V_{CTL1}=V_{CTL3}=3.3V$ ,  $V_{CTL2}=0V$ ,  $f=5400MHz$ )

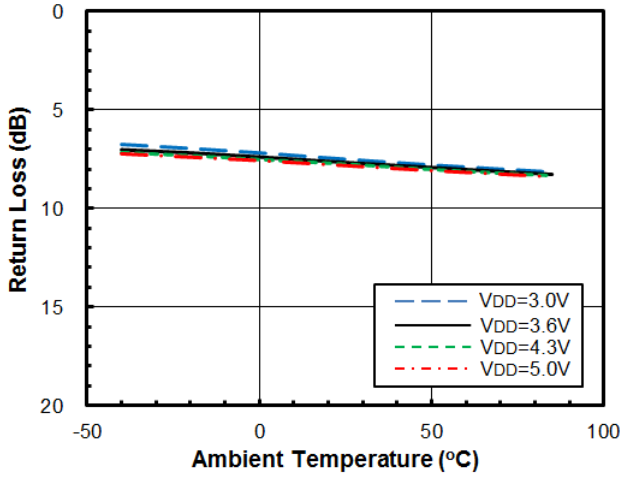

**LNAOUT Port Return Loss vs. Ambient Temperature**

( $V_{CTL1}=V_{CTL3}=3.3V$ ,  $V_{CTL2}=0V$ ,  $f=5400MHz$ )

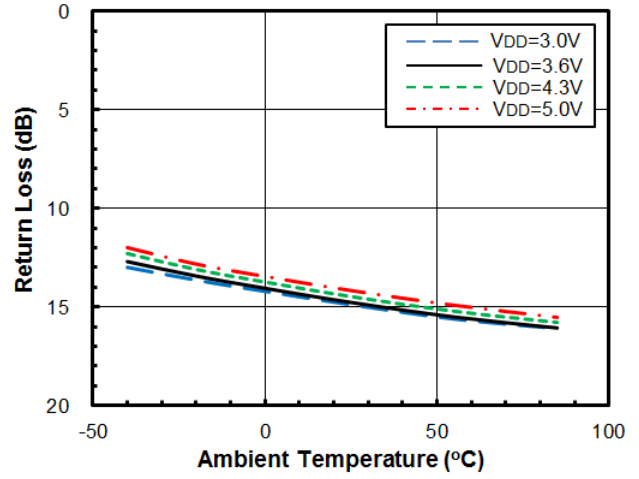

**Switching Time vs. Ambient Temperature**

(TX mode to Bypass mode)

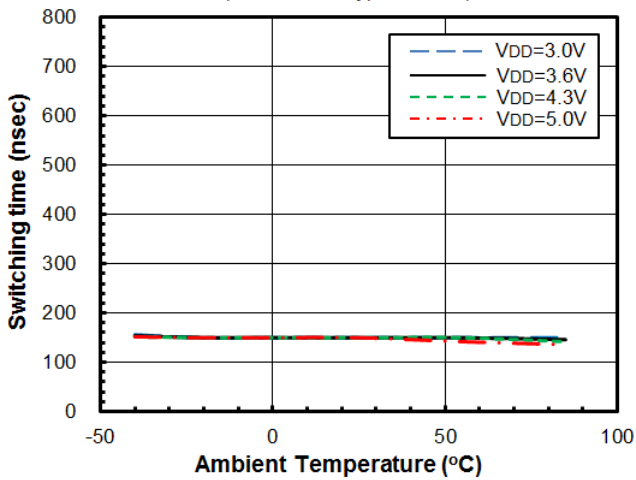

## ■ ELECTRICAL CHARACTERISTICS (RX Bypass mode)

$V_{DD}=3.6V$ ,  $V_{CTL1}=3.3V$ ,  $V_{CTL2}=V_{CTL3}=0V$ ,  $T_a=+25^\circ C$ ,  $Z_s=Z_l=50\Omega$

**Bypass mode Loss vs. frequency**

( $V_{DD}=3.6V$ ,  $V_{CTL1}=3.3V$ ,  $V_{CTL2}=V_{CTL3}=0V$ )

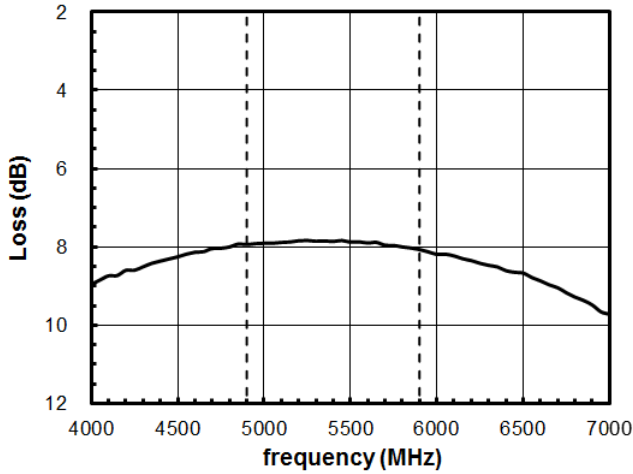

**Loss vs. Pin**

( $V_{DD}=3.6V$ ,  $V_{CTL1}=3.3V$ ,  $V_{CTL2}=V_{CTL3}=0V$ ,  $f=5400MHz$ )

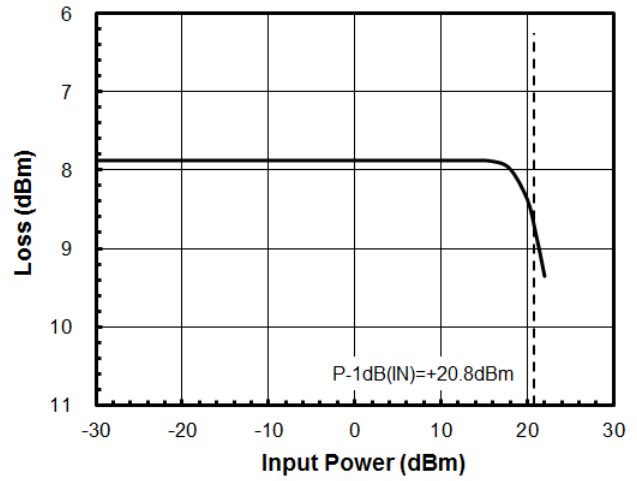

**Pout vs. Pin**

( $V_{DD}=3.6V$ ,  $V_{CTL1}=3.3V$ ,  $V_{CTL2}=V_{CTL3}=0V$ ,  $f=5400MHz$ )

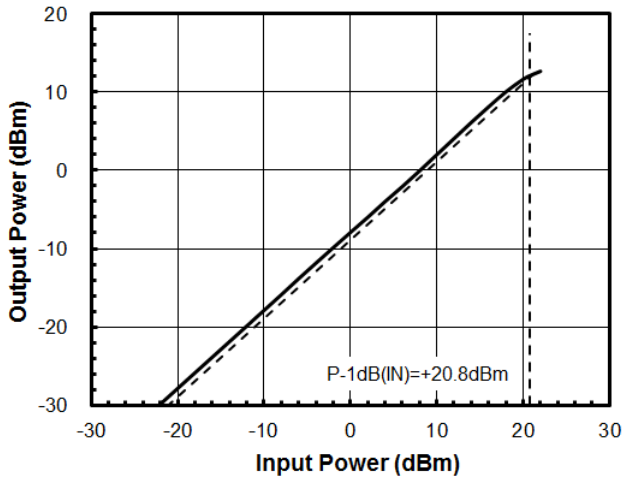

**P-1dB(IN) vs. frequency**

( $V_{DD}=3.6V$ ,  $V_{CTL1}=3.3V$ ,  $V_{CTL2}=V_{CTL3}=0V$ )

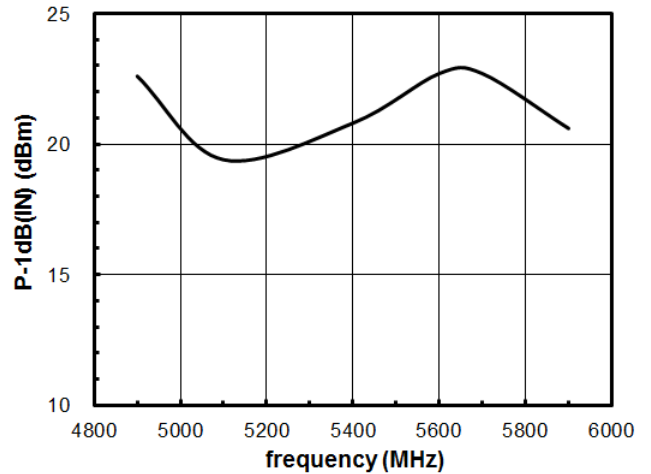

**Pout, IM3 vs. Pin**

( $V_{DD}=3.6V$ ,  $V_{CTL1}=3.3V$ ,  $V_{CTL2}=V_{CTL3}=0V$ ,  $f_1=5400MHz$ ,  $f_2=f_1+100kHz$ )

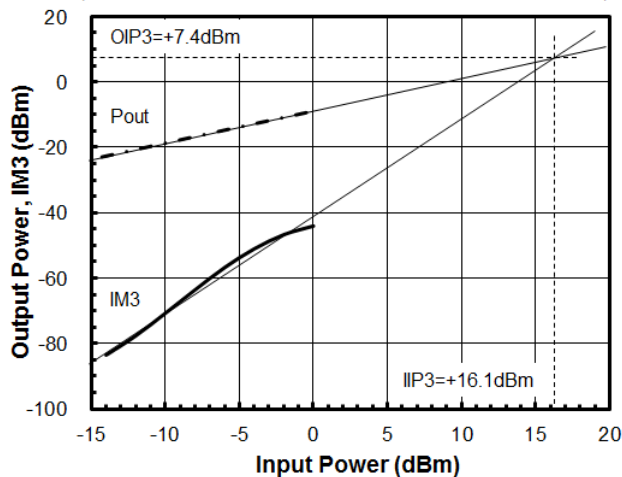

**IIP3, OIP3 vs. frequency**

( $V_{DD}=3.6V$ ,  $V_{CTL1}=3.3V$ ,  $V_{CTL2}=V_{CTL3}=0V$ ,  $f_1=4900\sim 5900MHz$ ,  $f_2=f_1+100kHz$ ,  $Pin=-10dBm$ )

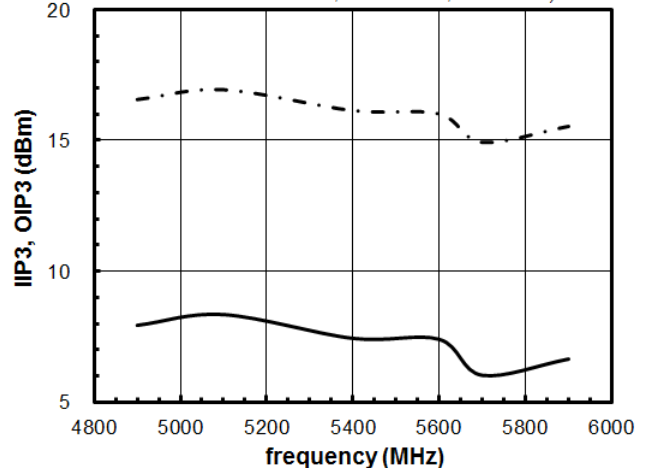

## ELECTRICAL CHARACTERISTICS (RX Bypass mode)

$V_{DD}=3.6V$ ,  $V_{CTL1}=3.3V$ ,  $V_{CTL2}=V_{CTL3}=0V$ ,  $T_a=+25^{\circ}C$ ,  $Z_s=Z_l=50\Omega$

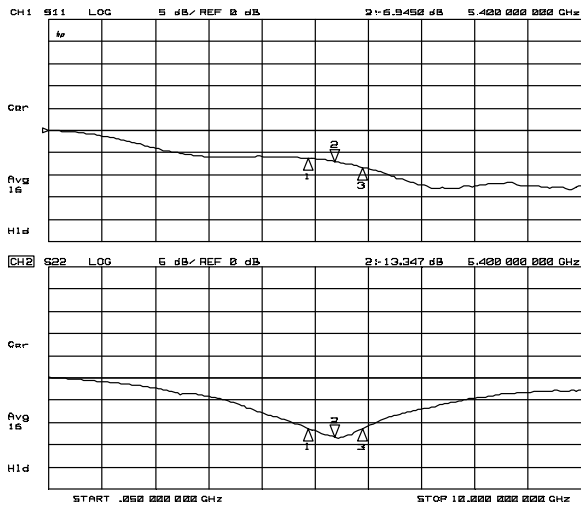

S11, S22 (f=50MHz to 10GHz)

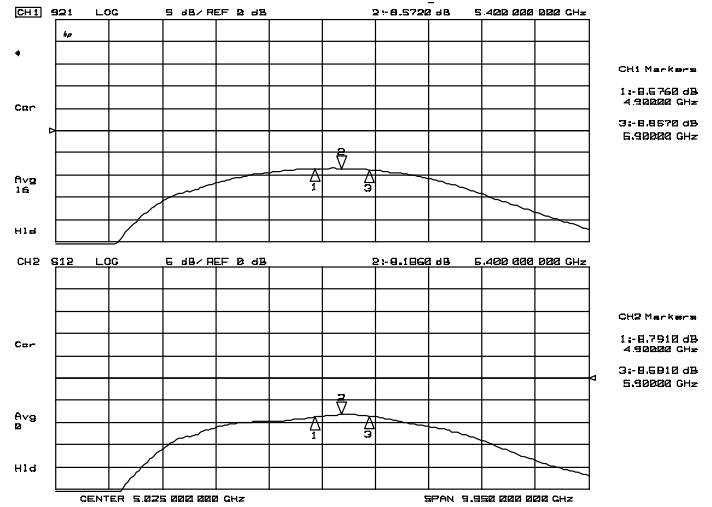

S21, S12 (f=50MHz to 10GHz)

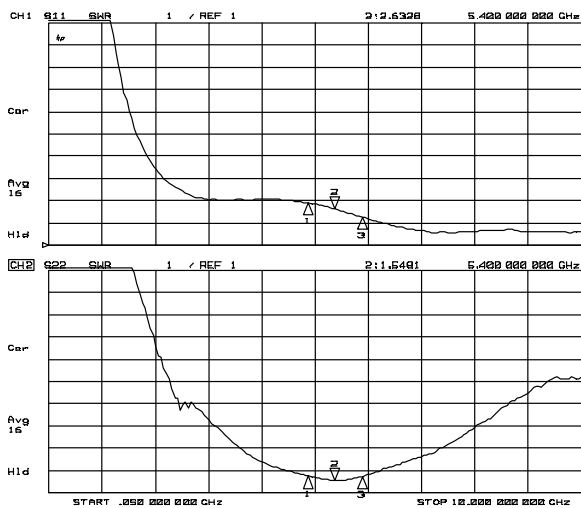

VSWRi, VSWRo (f=50MHz to 10GHz)

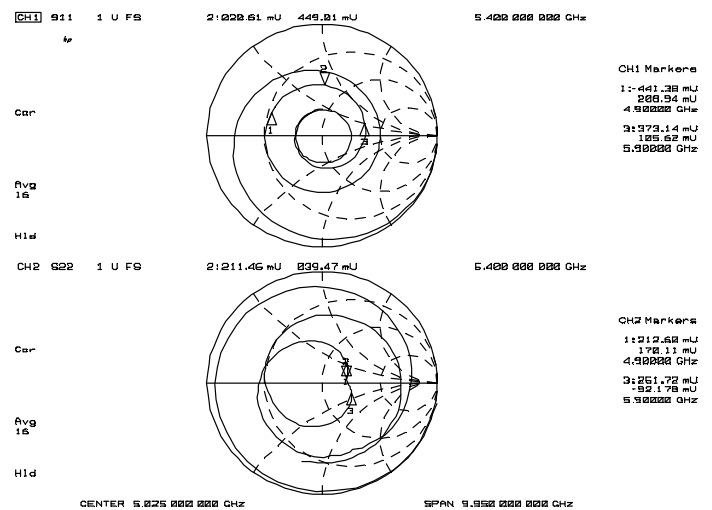

Zin, Zout (f=50MHz to 10GHz)

## ELECTRICAL CHARACTERISTICS (RX Bypass mode)

$V_{CTL1}=3.3V, V_{CTL2}=V_{CTL3}=0V, Z_s=Z_l=50\Omega$

### Loss vs. Ambient Temperature

( $V_{CTL1}=3.3V, V_{CTL2}=V_{CTL3}=0V, f=5400MHz$ )

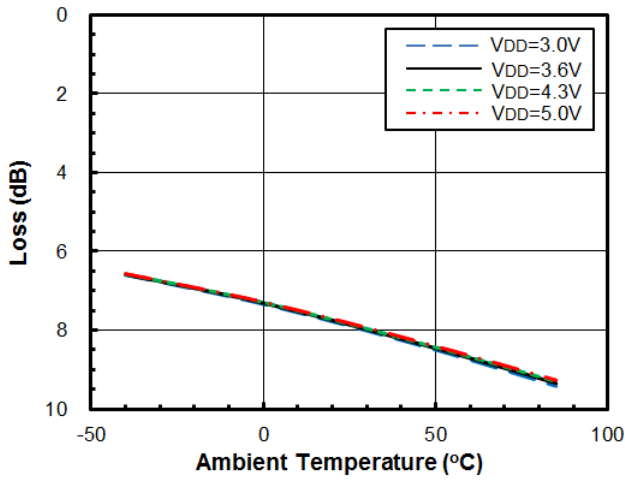

### P-1dB(IN) vs. Ambient Temperature

( $V_{CTL1}=3.3V, V_{CTL2}=V_{CTL3}=0V, f=5400MHz$ )

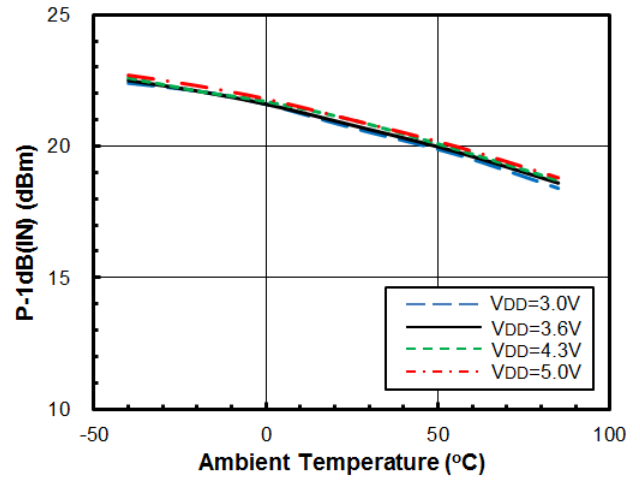

### IIP3 vs. Ambient Temperature

( $V_{CTL1}=3.3V, V_{CTL2}=V_{CTL3}=0V, f_1=5400MHz, f_2=f_1+100kHz, Pin=-10dBm$ )

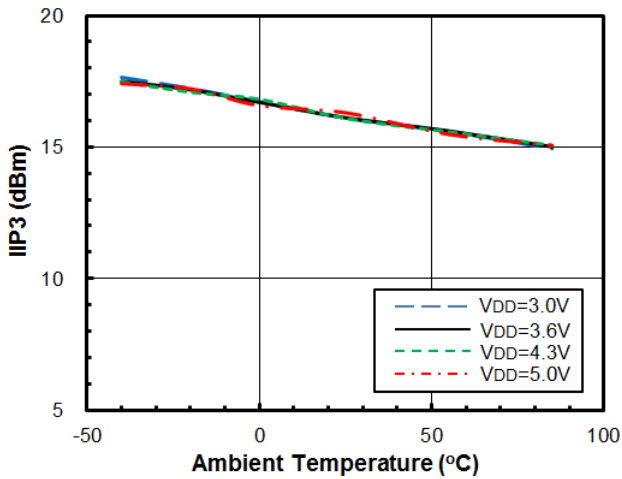

### ANT Port Return Loss vs. Ambient Temperature

( $V_{CTL1}=3.3V, V_{CTL2}=V_{CTL3}=0V, f=5400MHz$ )

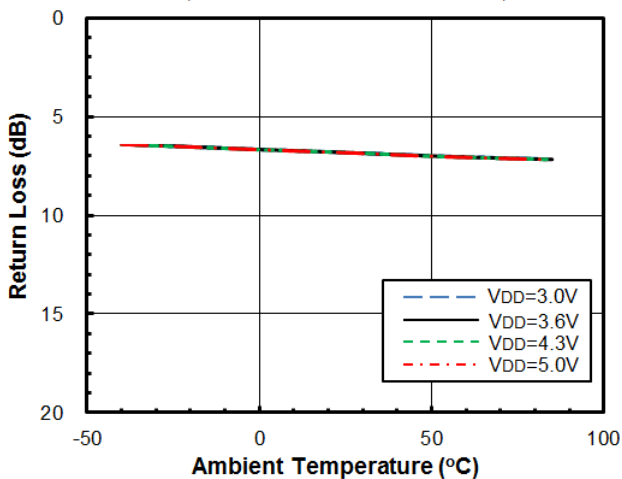

### LNAOUT Port Return Loss vs. Ambient Temperature

( $V_{CTL1}=3.3V, V_{CTL2}=V_{CTL3}=0V, f=5400MHz$ )

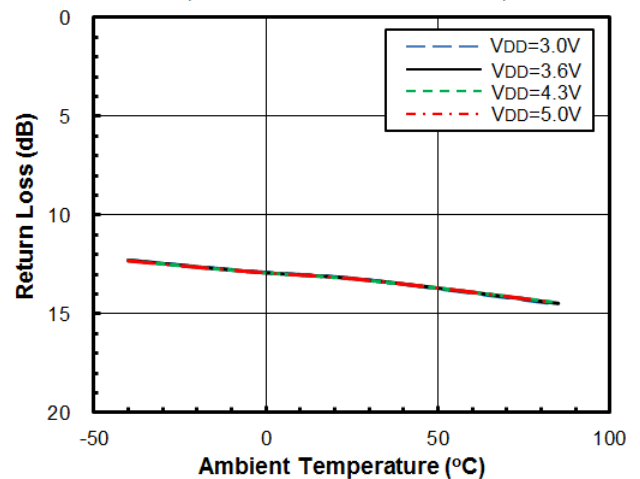

## ■ ELECTRICAL CHARACTERISTICS (TX mode)

$V_{DD}=3.6V$ ,  $V_{CTL1}=V_{CTL3}=0V$ ,  $V_{CTL2}=3.3V$ ,  $T_a=+25^{\circ}C$ ,  $Z_s=Z_l=50\Omega$

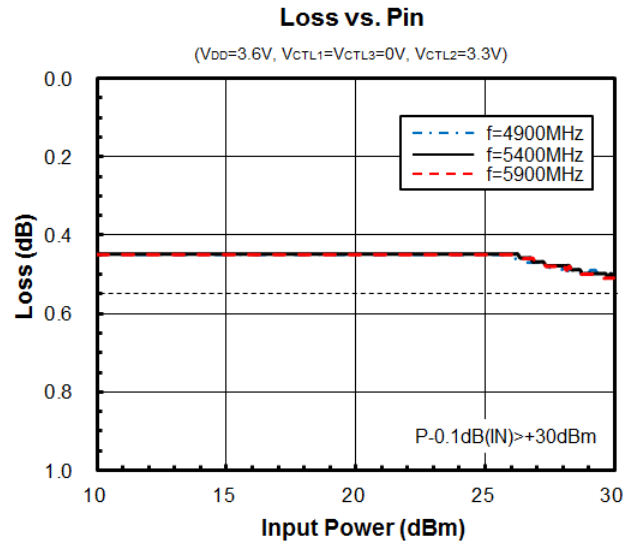
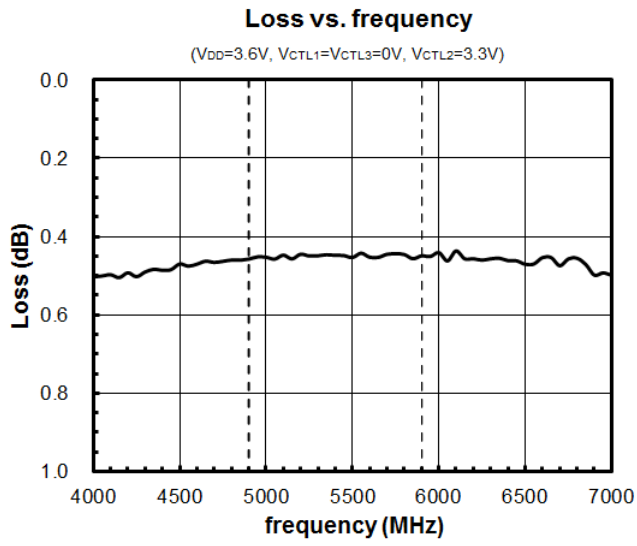

## ELECTRICAL CHARACTERISTICS (TX mode)

$V_{DD}=3.6V$ ,  $V_{CTL1}=V_{CTL3}=0V$ ,  $V_{CTL2}=3.3V$ ,  $T_a=+25^\circ C$ ,  $Z_S=Z_L=50\Omega$

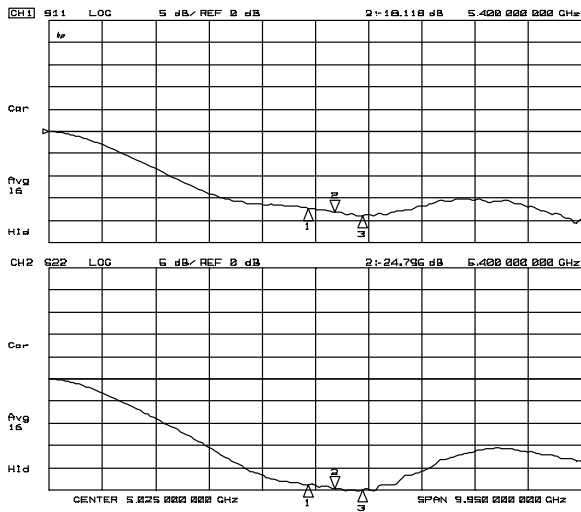

S11, S22 (f=50MHz to 10GHz)

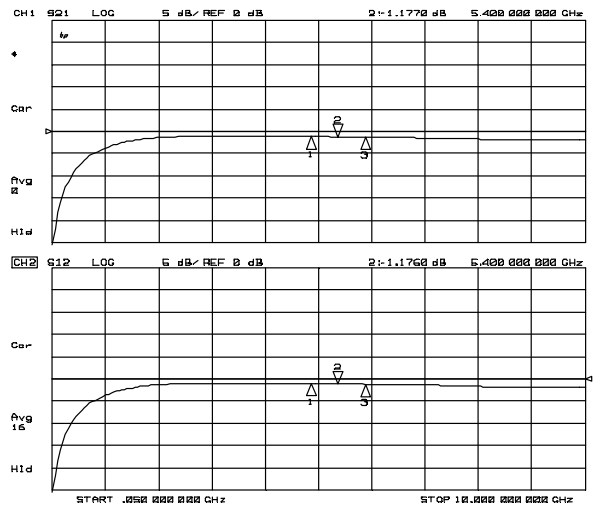

S21, S12 (f=50MHz to 10GHz)

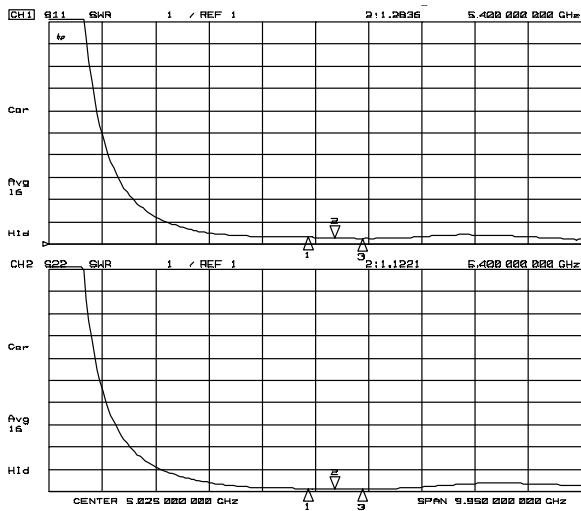

VSWRi, VSWRo (f=50MHz to 10GHz)

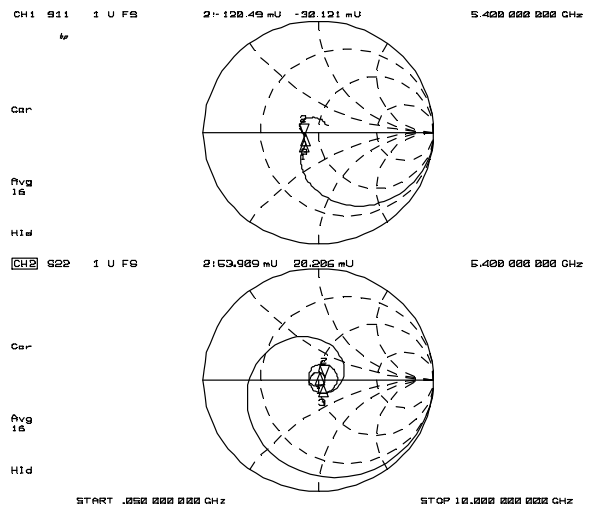

Zin, Zout (f=50MHz to 10GHz)



## ■ ELECTRICAL CHARACTERISTICS (TX mode)

$V_{DD}=3.6V$ ,  $V_{CTL1}=V_{CTL3}=0V$ ,  $V_{CTL2}=3.3V$ ,  $Z_S=Z_I=50\Omega$

**Loss vs. Ambient Temperature**

( $V_{DD}=3.6V$ ,  $V_{CTL1}=V_{CTL3}=0V$ ,  $V_{CTL2}=3.3V$ ,  $f=5400MHz$ )

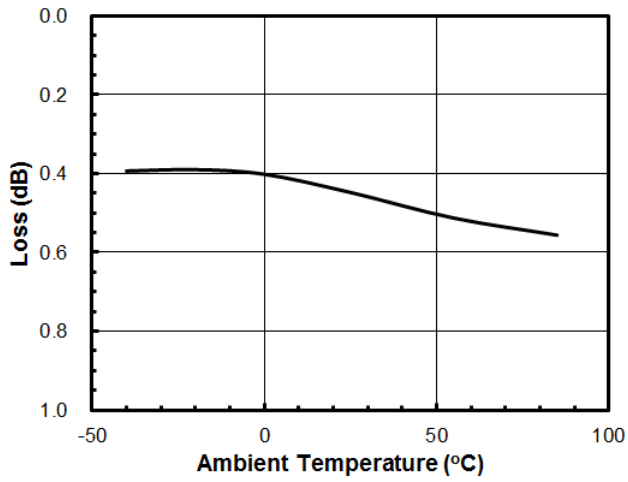

**ANT Port Return Loss vs. Ambient Temperature**

( $V_{DD}=3.6V$ ,  $V_{CTL1}=V_{CTL3}=0V$ ,  $V_{CTL2}=3.3V$ ,  $f=5400MHz$ )

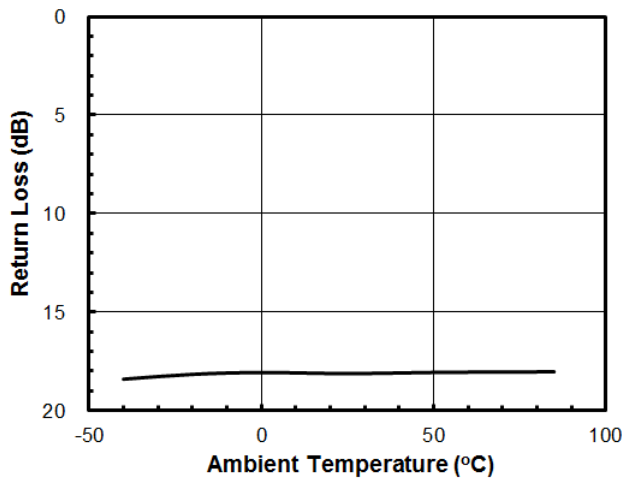

**LNAOUT Port Return Loss vs. Ambient Temperature**

( $V_{DD}=3.6V$ ,  $V_{CTL1}=V_{CTL3}=0V$ ,  $V_{CTL2}=3.3V$ ,  $f=5400MHz$ )

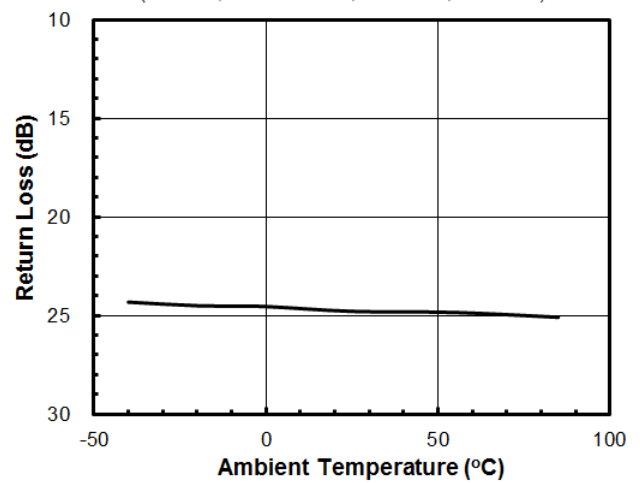

## APPLICATION CIRCUIT

(TOP VIEW)

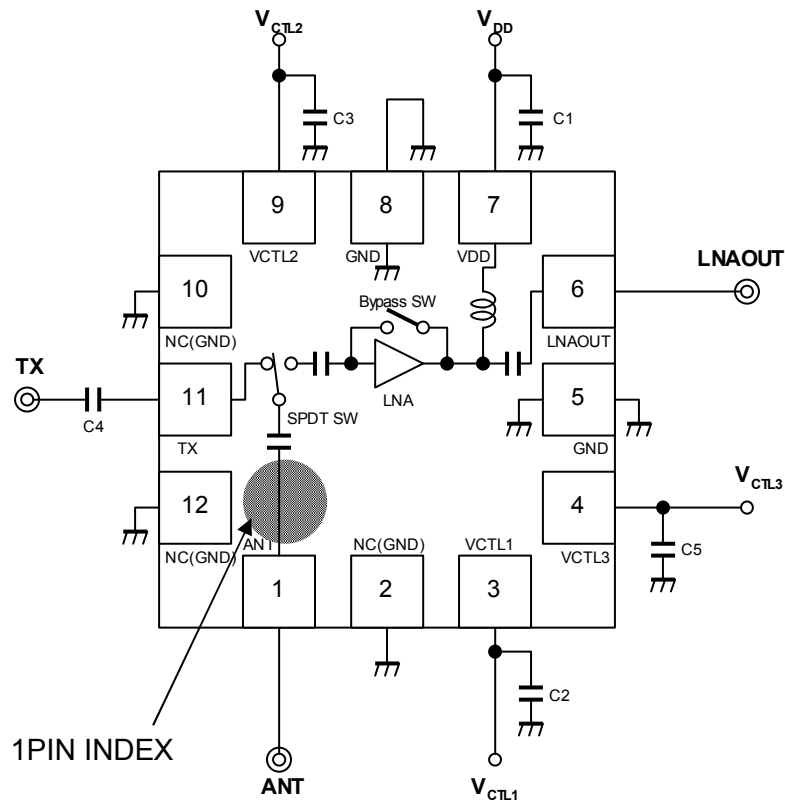

## PARTS LIST

ID No.	Value	Notes
C1	0.1 $\mu$ F	Murata MFG (GRM03 series)
C2, C3, C5	10pF	
C4	27pF	

## APPLIED CIRCUIT BOARD EXAMPLE

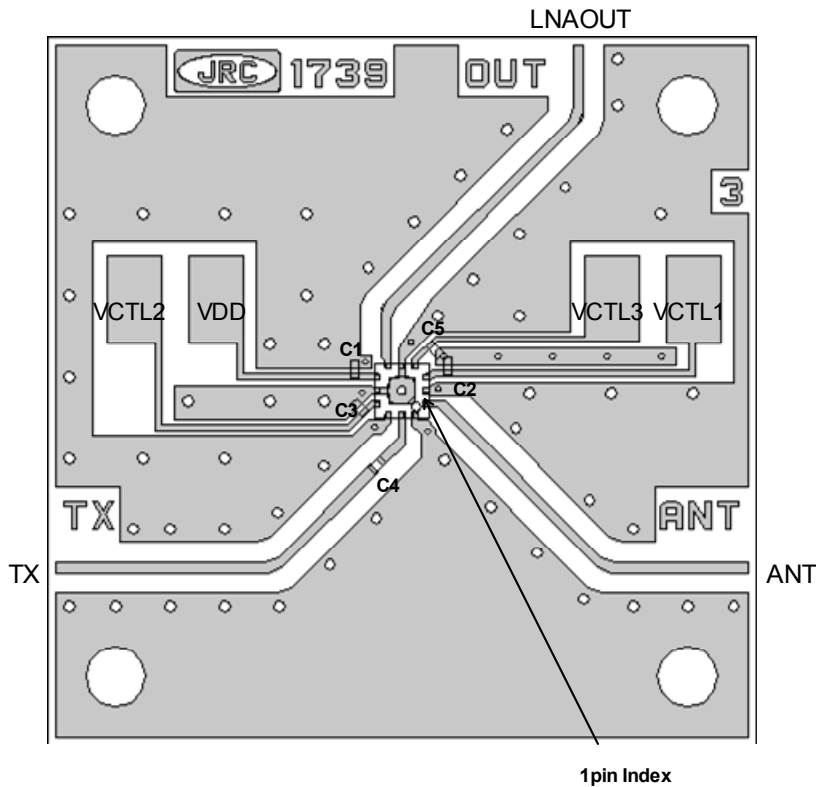



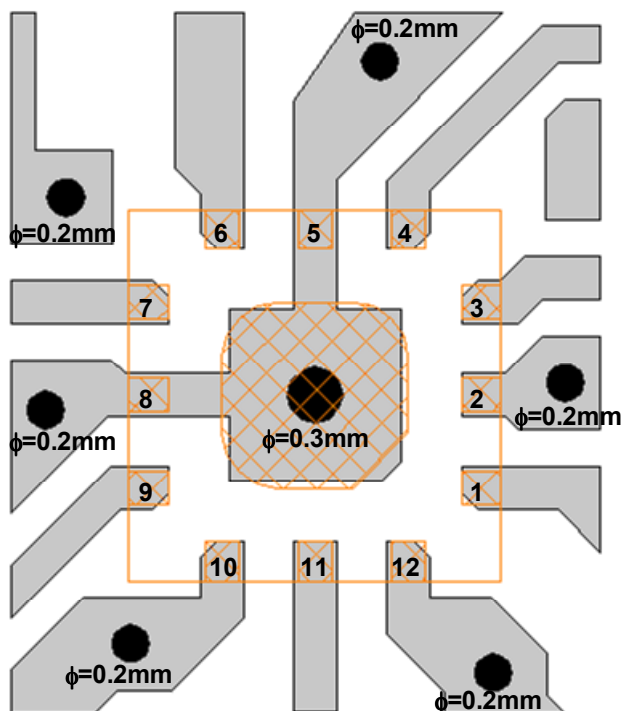

### PCB Information

Substrate: FR-4  
 Thickness: 0.2mm  
 Microstrip line width: 0.37mm ( $Z_0=50\Omega$ )  
 Size: 26.0mm x 26.0mm

### <PCB LAYOUT GUIDELINE>



-  PCB
-  PKG Terminal
-  PKG Outline
-  GND Via Hole  
Diameter:  $\phi=0.2 / 0.3\text{mm}$

### PRECAUTIONS

- [1] All external parts should be placed as close as possible to the IC.
- [2] For avoiding the degradation of RF performance, the bypass capacitor (C1) should be placed as close as possible to VDD terminal.
- [3] For good RF performance, the ground terminals must be placed possibly close to ground plane of substrate, and through holes for GND should be placed near by the pin connection.

## RECOMMENDED FOOTPRINT PATTERN (QFN12-51 PACKAGE Reference)

PKG: 2.0mm x 2.0mm  
Pin pitch: 0.5mm

: Land

: Mask (Open area) \*Metal mask thickness: 100μm

: Resist (Open area)

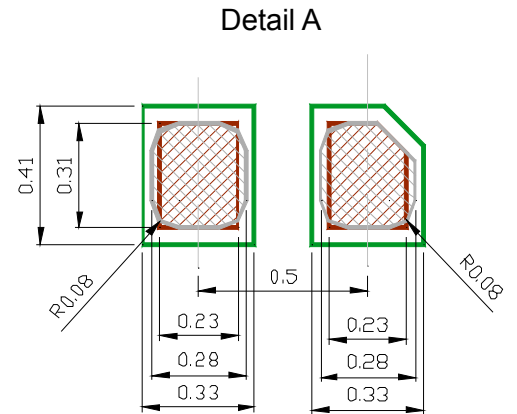
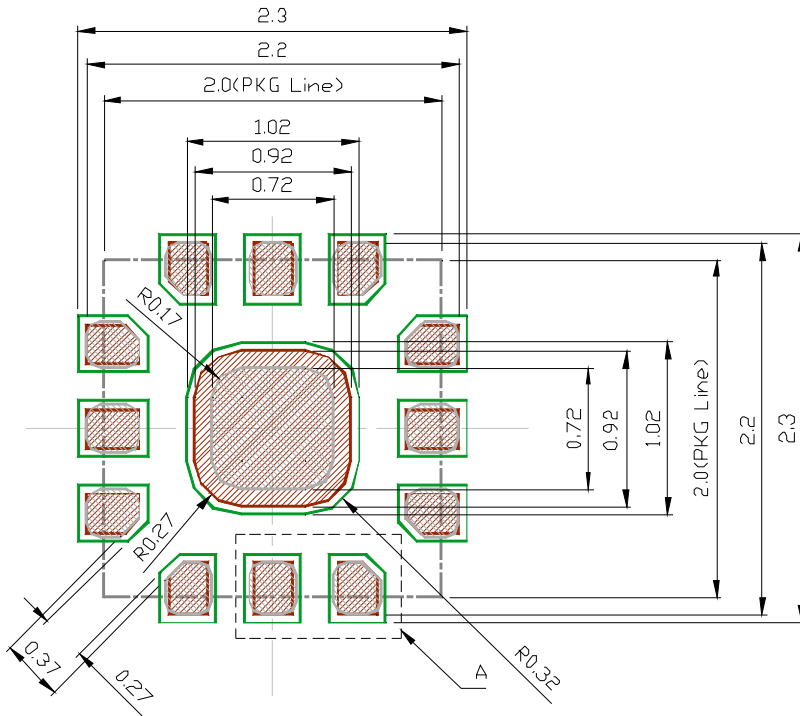

## ■ NOISE FIGURE MEASUREMENT BLOCK DIAGRAM

### Measuring instruments

NF Analyzer : Agilent N8975A  
 Noise Source : Agilent 346A

### Setting the NF analyzer

Measurement mode form

Device under test : Amplifier  
 System downconverter : off

Mode setup form

Sideband : LSB  
 Averages : 16  
 Average mode : Point  
 Bandwidth : 4MHz  
 Loss comp : off  
 Tcold : setting the temperature of noise source (303K)

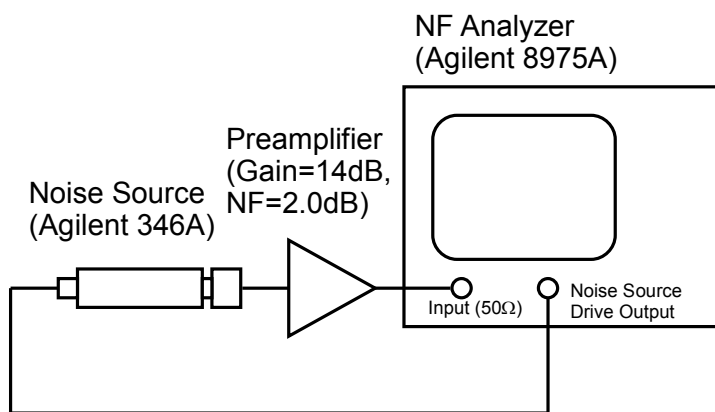

**Calibration setup**

- \* Preamplifier is used to improve NF measurement accuracy.
- \* Noise source, preamplifier and NF analyzer are connected directly.

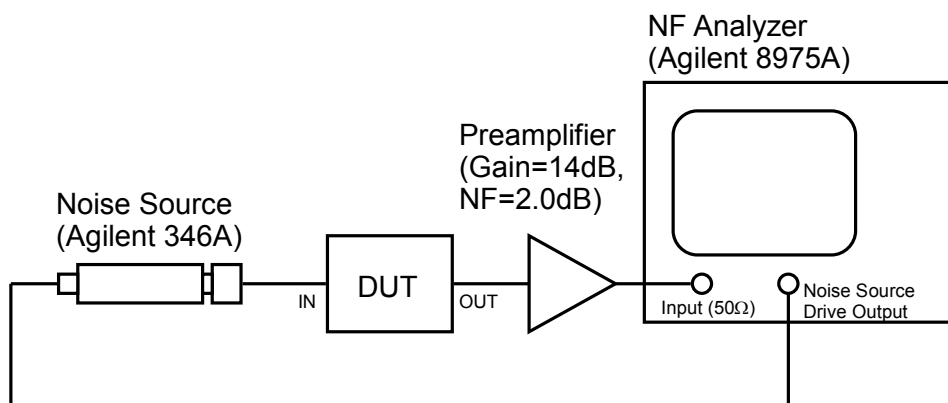

**Measurement Setup**

- \* Noise source, DUT, preamplifier and NF analyzer are connected directly.

## PACKAGE OUTLINE (QFN12-51)

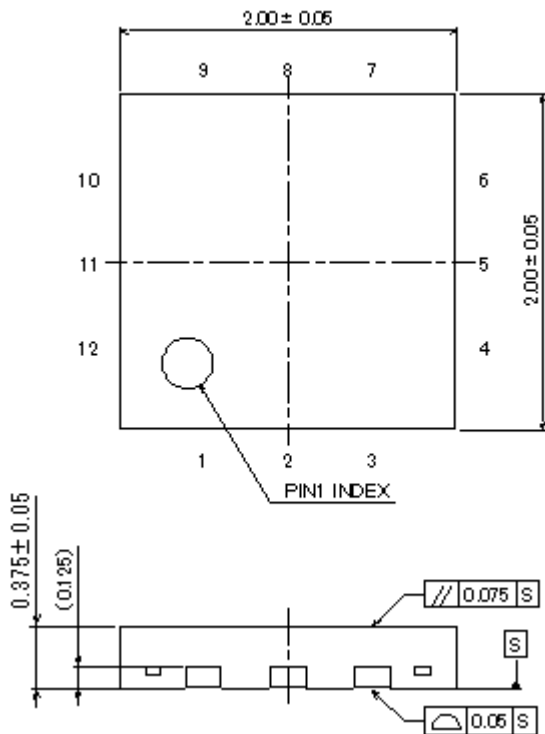

Unit	: mm
Board	: Copper
Terminal Treat	: Ni/Pd/Au plating
Molding Material	: Epoxy resin
Weight	: 4.7mg

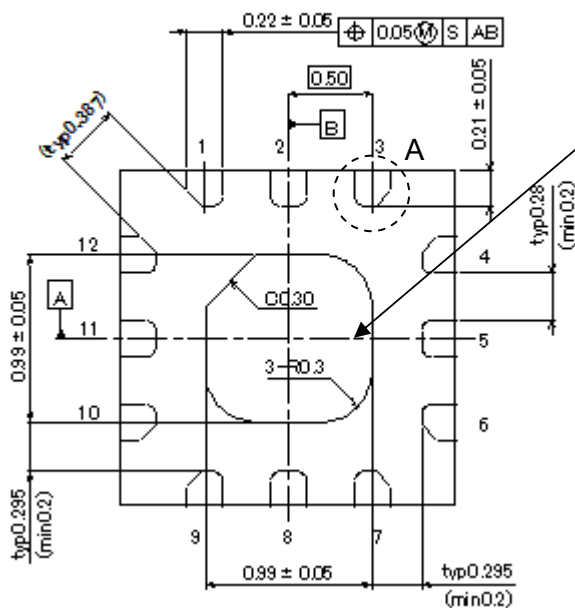

Exposed PAD  
Ground connection is required.

Details of "A" part

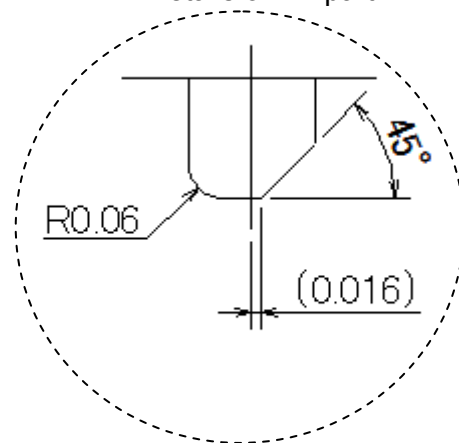

### Cautions on using this product

- This product contains Gallium-Arsenide (GaAs) which is a harmful material.
- Do NOT eat or put into mouth.
  - Do NOT dispose in fire or break up this product.
  - Do NOT chemically make gas or powder with this product.
  - To waste this product, please obey the relating law of your country.

### [CAUTION]

The specifications on this databook are only given for information, without any guarantee as regards either mistakes or omissions. The application circuits in this databook are described only to show representative usages of the product and not intended for the guarantee or permission of any right including the industrial rights.

This product may be damaged with electric static discharge (ESD) or spike voltage. Please handle with care to avoid these damages.

# Mouser Electronics

Authorized Distributor

Click to View Pricing, Inventory, Delivery & Lifecycle Information:

[NJR:](#)

[NJG1739K51-TE1](#)



## Стандарт Электрон Связь

Мы молодая и активно развивающаяся компания в области поставок электронных компонентов. Мы поставляем электронные компоненты отечественного и импортного производства напрямую от производителей и с крупнейших складов мира.

Благодаря сотрудничеству с мировыми поставщиками мы осуществляем комплексные и плановые поставки широчайшего спектра электронных компонентов.

Собственная эффективная логистика и склад в обеспечивает надежную поставку продукции в точно указанные сроки по всей России.

Мы осуществляем техническую поддержку нашим клиентам и предпродажную проверку качества продукции. На все поставляемые продукты мы предоставляем гарантию .

Осуществляем поставки продукции под контролем ВП МО РФ на предприятия военно-промышленного комплекса России , а также работаем в рамках 275 ФЗ с открытием отдельных счетов в уполномоченном банке. Система менеджмента качества компании соответствует требованиям ГОСТ ISO 9001.

Минимальные сроки поставки, гибкие цены, неограниченный ассортимент и индивидуальный подход к клиентам являются основой для выстраивания долгосрочного и эффективного сотрудничества с предприятиями радиоэлектронной промышленности, предприятиями ВПК и научно-исследовательскими институтами России.

С нами вы становитесь еще успешнее!

### Наши контакты:

**Телефон:** +7 812 627 14 35

**Электронная почта:** [sales@st-electron.ru](mailto:sales@st-electron.ru)

**Адрес:** 198099, Санкт-Петербург,  
Промышленная ул, дом № 19, литера Н,  
помещение 100-Н Офис 331