



SM802116

ClockWorks™ Fibre Channel (106.25MHz, 212.5MHz) Ultra-Low Jitter, LVDS Frequency Synthesizer

General Description

The SM802116 is a member of the ClockWorks™ family of devices from Micrel and provides an extremely low-noise timing solution for Fibre Channel clock signals. It is based upon a unique patented RotaryWave® architecture that provides very-low phase noise.

The device operates from a 3.3V or 2.5V power supply and synthesizes LVDS output clocks at 106.25MHz or 212.5MHz. There are normally two clock outputs, but one output can be achieved by powering down the second output with the OE pin. The SM802116 accepts a 26.5625MHz crystal or LVCMOS reference clock.

Data sheet and support documentation can be found on Micrel's web site at: www.micrel.com.

Features

- Generates one or two LVDS clock outputs at 106.25MHz or 212.5MHz
- 2.5V or 3.3V operating range
- Typical phase jitter @ 106.25MHz (637kHz to 10MHz): 190fs
- Industrial temperature range (-40°C to +85°C)
- Green, RoHS, and PFOS compliant
- Available in 24-pin 4mm × 4mm QFN package

Applications

- Fibre Channel
- Storage Networking (SAN, NAS)

Block Diagram

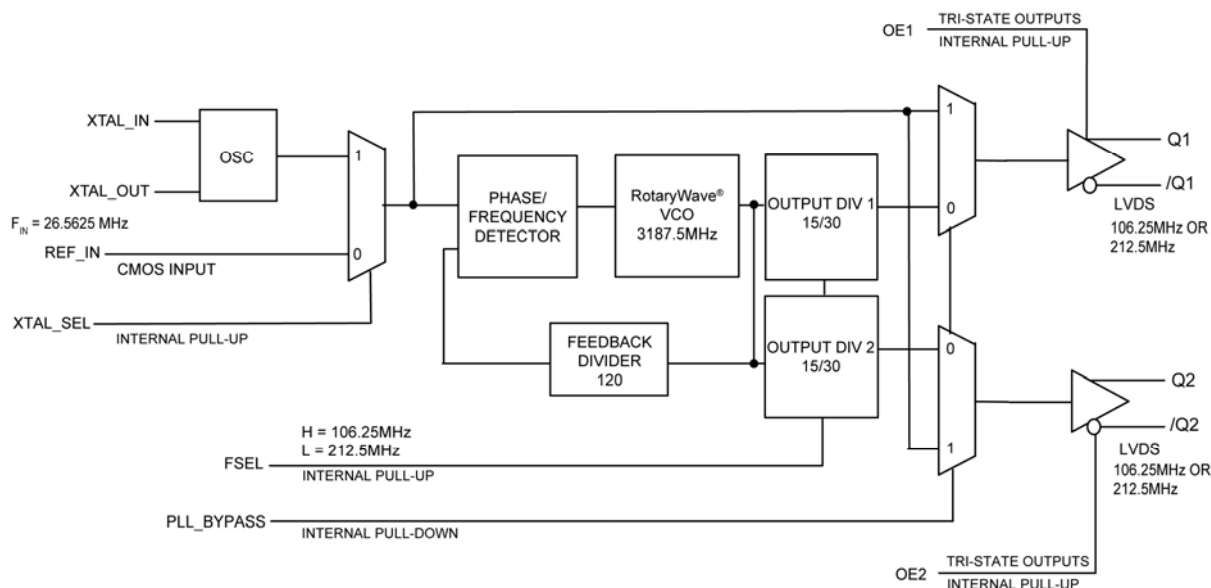

ClockWorks is a trademark of Micrel, Inc
RotaryWave is a registered trademark of Multigig, Inc.

Ordering Information⁽¹⁾

Part Number	Marking	Shipping	Temperature Range	Package
SM802116UMG	802116	Tube	-40°C to +85°C	24-Pin QFN
SM802116UMGR	802116	Tape and Reel	-40°C to +85°C	24-Pin QFN

Note:

1. Devices are Green, RoHS, and PFOS compliant.

Pin Configuration

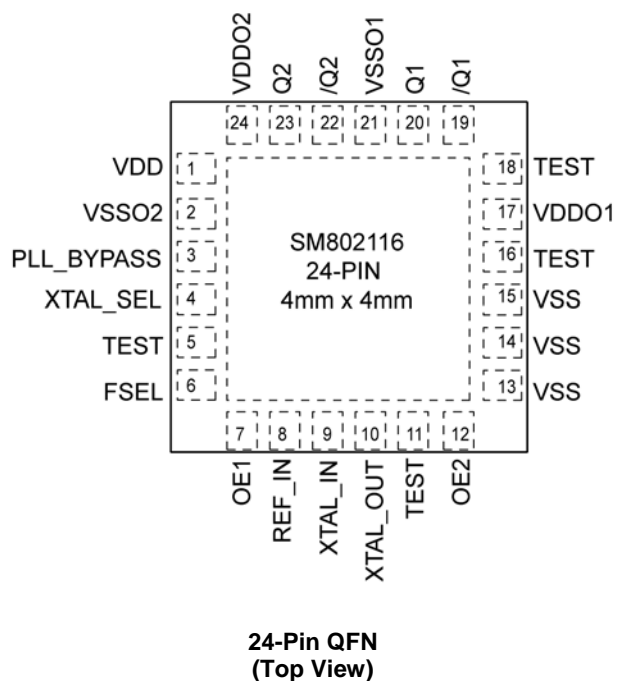

Pin Description

Pin Number	Pin Name	Pin Type	Pin Level	Pin Function
19, 20	/Q1, Q1	O, (DIF)	LVDS	Differential Clock Output from Bank 1 106.25MHz or 212.5MHz
22, 23	/Q2, Q2	O, (DIF)	LVDS	Differential Clock Output from Bank 2 106.25MHz or 212.5MHz
24	VDDO2	PWR		Power Supply for Output Bank 2
2	VSSO2	PWR		Power Supply Ground for Output Bank 2
3	PLL_BYPASS	I, (SE)	LVC MOS	PLL Bypass, Selects Output Source 0 = Normal PLL Operation 1 = Output from Input Reference Clock or Crystal 45KΩ pull-down
4	XTAL_SEL	I, (SE)	LVC MOS	Selects PLL Input Reference Source 0 = REF_IN, 1 = XTAL, 45KΩ pull-up

Pin Description (Continued)

Pin Number	Pin Name	Pin Type	Pin Level	Pin Function
5, 11, 16, 18	TEST			Factory Test pins, Do not connect anything to these pins.
1	VDD	PWR		Core Power Supply
13, 14, 15	VSS	PWR		Core Power Supply Ground
17	VDDO1	PWR		Power Supply for Output Bank 1
21	VSSO1	PWR		Power Supply Ground for Output Bank 1
8	REF_IN	I, (SE)	LVC MOS	Reference Clock Input
9	XTAL_IN	I, (SE)	12pF crystal	Crystal Reference Input, no load caps needed. (see Figure 5)
10	XTAL_OUT	O, (SE)	12pF crystal	Crystal Reference Output, no load caps needed. (see Figure 5)
6	FSEL	I, (SE)	LVC MOS	Frequency Select, 1 = 106.25MHz, 0 = 212.5MHz, 45K Ω pull-up
7	OE1	I, (SE)	LVC MOS	Output Enable, Q1 disables to tri-state, 0 = Disabled, 1 = Enabled, 45K Ω pull-up
12	OE2	I, (SE)	LVC MOS	Output Enable, Q2 disables to tri-state, 0 = Disabled, 1 = Enabled, 45K Ω pull-up

Truth Tables

PLL_BYPASS	XTAL_SEL	OE2	OE1	INPUT	OUTPUT
0	–	1	1	–	PLL
1	–	1	1	–	XTAL/REF_IN
–	0	1	1	REF_IN	–
–	1	1	1	XTAL	–
–	–	0	1	–	Q2 Tri-state
–	–	1	0	–	Q1 Tri-state

FSEL	Output Frequency (MHz)
0	212.5
1	106.25

Absolute Maximum Ratings⁽¹⁾

Supply Voltage (V_{DD} , $V_{DDO1/2}$)	+4.6V
Input Voltage (V_{IN})	-0.50V to $V_{DD} + 0.5V$
Lead Temperature (soldering, 20s)	260°C
Case Temperature	115°C
Storage Temperature (T_s)	-65°C to +150°C

Operating Ratings⁽²⁾

Supply Voltage (V_{DD} , $V_{DDO1/2}$)	+2.375V to +3.465V
Ambient Temperature (T_A)	-40°C to +85°C
Junction Thermal Resistance ⁽³⁾	
QFN (θ_{JA})	
Still-Air	50°C/W
QFN (ψ_{JB})	
Junction-to-Board	30°C/W

DC Electrical Characteristics⁽⁴⁾

$$V_{DD} = V_{DDO1/2} = 3.3V \pm 5\% \text{ or } 2.5V \pm 5\%$$

$$V_{DD} = 3.3V \pm 5\%, V_{DDO1/2} = 3.3V \pm 5\% \text{ or } 2.5V \pm 5\%$$

$$T_A = -40^\circ\text{C to } +85^\circ\text{C.}$$

Symbol	Parameter	Condition	Min.	Typ.	Max.	Units
V_{DD} , $V_{DDO1/2}$	2.5V Operating Voltage		2.375	2.5	2.625	V
V_{DD} , $V_{DDO1/2}$	3.3V Operating Voltage		3.135	3.3	3.465	V
I_{DD} REF_IN	Supply current $V_{DD} + V_{DDO}$ XTAL_SEL = 0 Outputs open	106.25MHz - 1 output		77	96	mA
		106.25MHz - 2 outputs		89	110	
		212.5MHz - 1 output		85	106	
		212.5MHz - 2 outputs		100	124	
I_{DD} XTAL	Supply current $V_{DD} + V_{DDO}$ XTAL_SEL = 1 Outputs open	106.25MHz - 1 output		87	108	mA
		106.25MHz - 2 outputs		99	123	
		212.5MHz - 1 output		97	120	
		212.5MHz - 2 outputs		111	137	

LVDS DC Electrical Characteristics⁽⁴⁾

$$V_{DD} = V_{DDO1/2} = 3.3V \pm 5\% \text{ or } 2.5V \pm 5\%$$

$$V_{DD} = 3.3V \pm 5\%, V_{DDO1/2} = 3.3V \pm 5\% \text{ or } 2.5V \pm 5\%$$

$$T_A = -40^\circ\text{C to } +85^\circ\text{C. } R_L = 100\Omega \text{ across Q and } /Q.$$

Symbol	Parameter	Condition	Min.	Typ.	Max.	Units
V_{OD}	Differential Output Voltage	Figure 1	275	350	475	mV
ΔV_{OD}	V_{OD} Magnitude Change				40	mV
V_{OS}	Offset Voltage		1.15	1.25	1.50	V
ΔV_{OS}	V_{OS} Magnitude Change				50	mV

Notes:

1. Permanent device damage may occur if absolute maximum ratings are exceeded. This is a stress rating only and functional operation is not implied at conditions other than those detailed in the operational sections of this data sheet. Exposure to absolute maximum rating conditions for extended periods may affect device reliability.
2. The data sheet limits are not guaranteed if the device is operated beyond the operating ratings.
3. Package thermal resistance assumes exposed pad is soldered (or equivalent) to the devices most negative potential on the PCB.
4. The circuit is designed to meet the AC and DC specifications shown in the above table(s) after thermal equilibrium has been established.

LVC MOS (PLL_BYPASS, XTAL_SEL, OE1/2, FSEL) DC Electrical Characteristics⁽⁴⁾

$V_{DD} = 3.3V \pm 5\%$, or $2.5V \pm 5\%$, $T_A = -40^\circ C$ to $+85^\circ C$.

Symbol	Parameter	Condition	Min.	Typ.	Max.	Units
V_{IH}	Input High Voltage		2		$V_{DD} + 0.3$	V
V_{IL}	Input Low Voltage		-0.3		0.8	V
I_{IH}	Input High Current	$V_{DD} = V_{IN} = 3.465V$			150	μA
I_{IL}	Input Low Current	$V_{DD} = 3.465V, V_{IN} = 0V$	-150			μA

REF_IN DC Electrical Characteristics⁽⁴⁾

$V_{DD} = 3.3V \pm 5\%$, or $2.5V \pm 5\%$, $T_A = -40^\circ C$ to $+85^\circ C$.

Symbol	Parameter	Condition	Min.	Typ.	Max.	Units
V_{IH}	Input High Voltage		1.1		$V_{DD} + 0.3$	V
V_{IL}	Input Low Voltage		-0.3		0.6	V
I_{IN}	Input Current	$XTAL_SEL = V_{IL}, V_{IN} = 0V$ to V_{DD}	-5		5	μA
		$XTAL_SEL = V_{IH}, V_{IN} = V_{DD}$		20		μA

Crystal Characteristics

Parameter	Condition	Min.	Typ.	Max.	Units
Mode of Oscillation	12pF Load	Fundamental, Parallel Resonant			
Frequency			26.5625		MHz
Equivalent Series Resistance (ESR)				50	Ω
Shunt Capacitor, C0			1	5	pF
Correlation Drive Level			10	100	μW

AC Electrical Characteristics^(4, 5)
 $V_{DD} = V_{DDO1/2} = 3.3V \pm 5\%$ or $2.5V \pm 5\%$
 $V_{DD} = 3.3V \pm 5\%$, $V_{DDO1/2} = 3.3V \pm 5\%$ or $2.5V \pm 5\%$
 $T_A = -40^\circ\text{C}$ to $+85^\circ\text{C}$. $R_L = 100\Omega$ across Q and /Q.

Symbol	Parameter	Condition	Min.	Typ.	Max.	Units
F _{OUT1}	Output Frequency 1	FSEL=1		106.25		MHz
F _{OUT2}	Output Frequency 2	FSEL=0		212.5		MHz
F _{REF}	Reference Input Frequency			26.5625		MHz
T _R /T _F	LVDS Output Rise/Fall Time	20% – 80%	100	220	400	ps
ODC	Output Duty Cycle		48	50	52	%
T _{SKEW}	Output-to-Output Skew	Note 6			45	ps
T _{LOCK}	PLL Lock Time				20	ms
T _{jitter} (∅)	RMS Phase Jitter ⁽⁷⁾	106.25MHz Integration Range (637kHz – 10MHz) Integration Range (12kHz – 20MHz) 212.5MHz Integration Range (637kHz – 10MHz) Integration Range (12kHz – 20MHz)		190 250 180 240		fs
	Spurious Noise Components	26.5625MHz using 106.25MHz 26.5625MHz using 212.5MHz		-90 -85		dBc

Notes:

- All phase noise measurements were taken with an Agilent 5052B phase noise system.
- Defined as skew between outputs at the same supply voltage and with equal load conditions; Measured at the output differential crossing points.
- Measured using 26.5625MHz crystal as the input reference source. If using an external reference input, use a low phase noise source. With an external reference, the phase noise will follow the input source phase noise up to about 1MHz.

Application Information

Input Reference

When operating with a crystal input reference, do not apply a switching signal to REF_IN.

Crystal Layout

Keep the layers under the crystal as open as possible and do not place switching signals or noisy supplies under the crystal.

Crystal load capacitance is built inside the die so no external capacitance is needed. See the *Selecting a Quartz crystal for the Clockworks Flex I Family of Precision Synthesizers* application note for further details.

Contact Micrel's HBW applications group if you need assistance on selecting a suitable crystal for your application at hbwhelp@micrel.com.

LVDS Outputs

LVDS outputs are to be terminated with 100Ω across Q and /Q. For best performance load all outputs. You can DC or AC-couple the outputs.

Phase Noise Plots

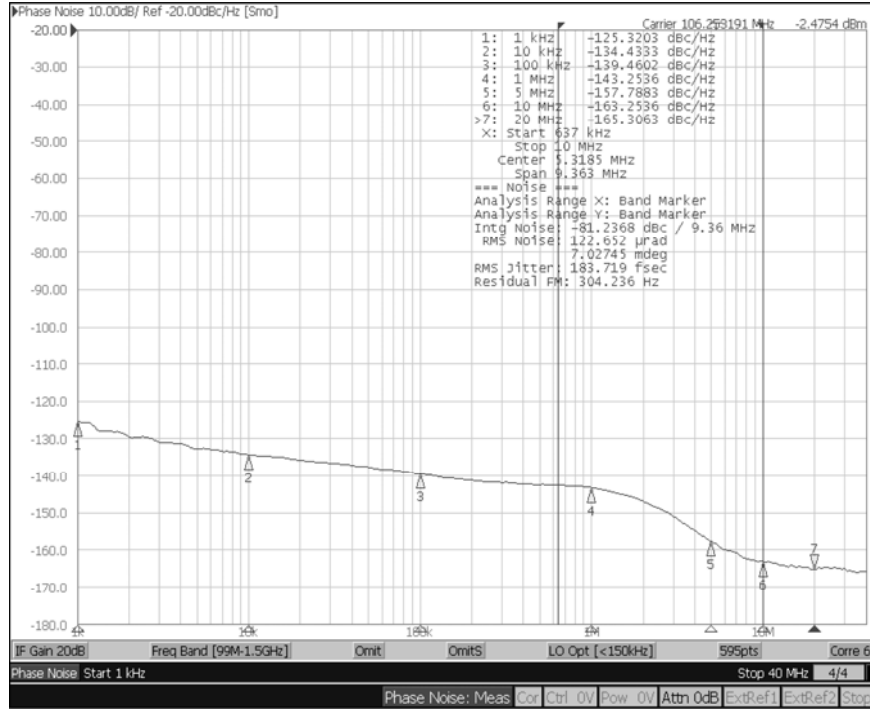

Phase Noise Plot: 106.25MHz, 637kHz – 10MHz 184fS

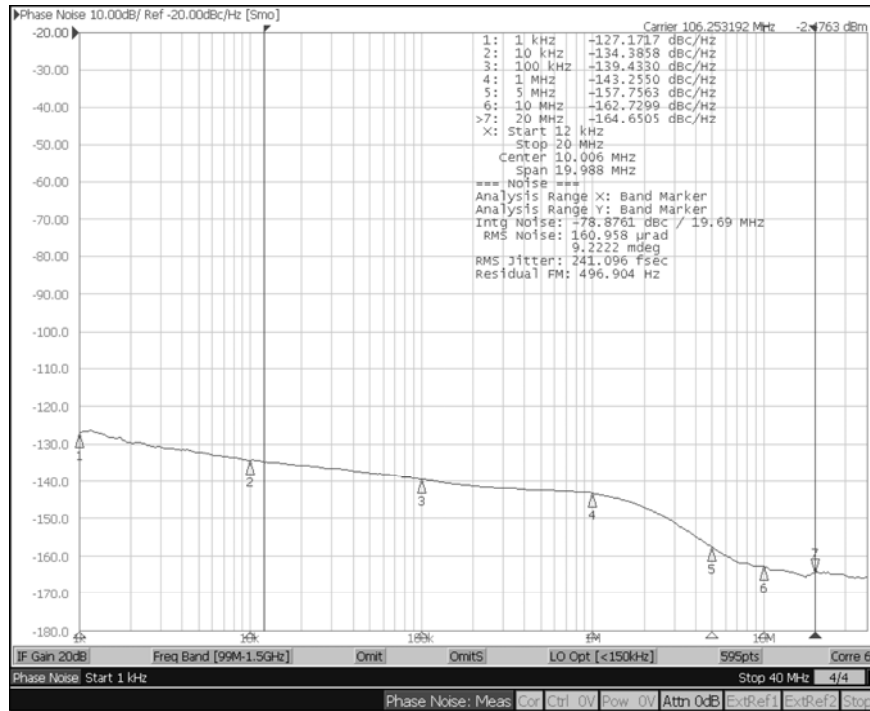

Phase Noise Plot: 106.25MHz, 12kHz – 20MHz 241fS

Phase Noise Plots (Continued)

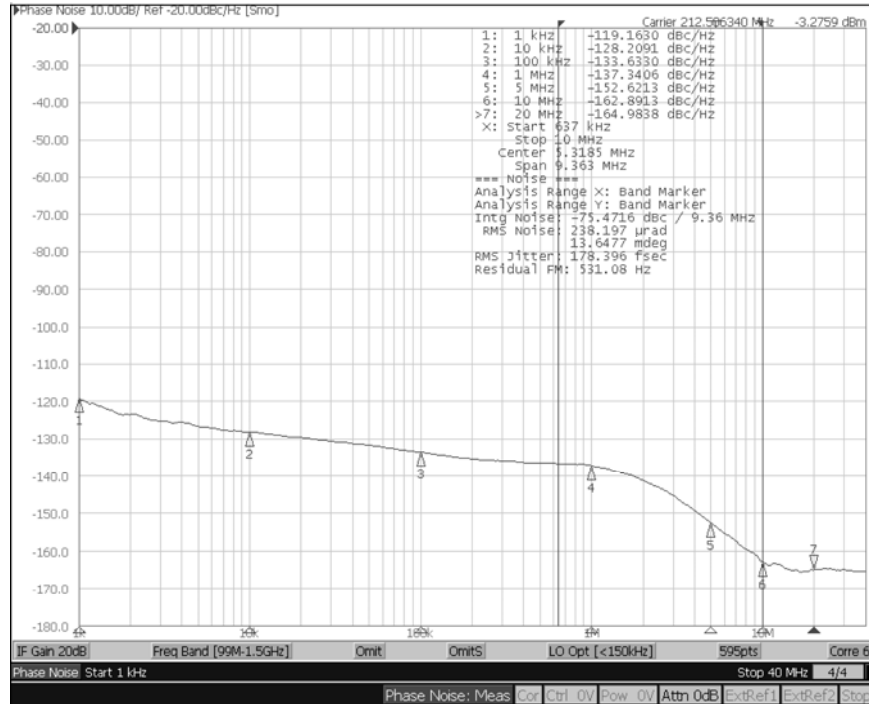

Phase Noise Plot: 212.5MHz, 637kHz – 10MHz 178fS

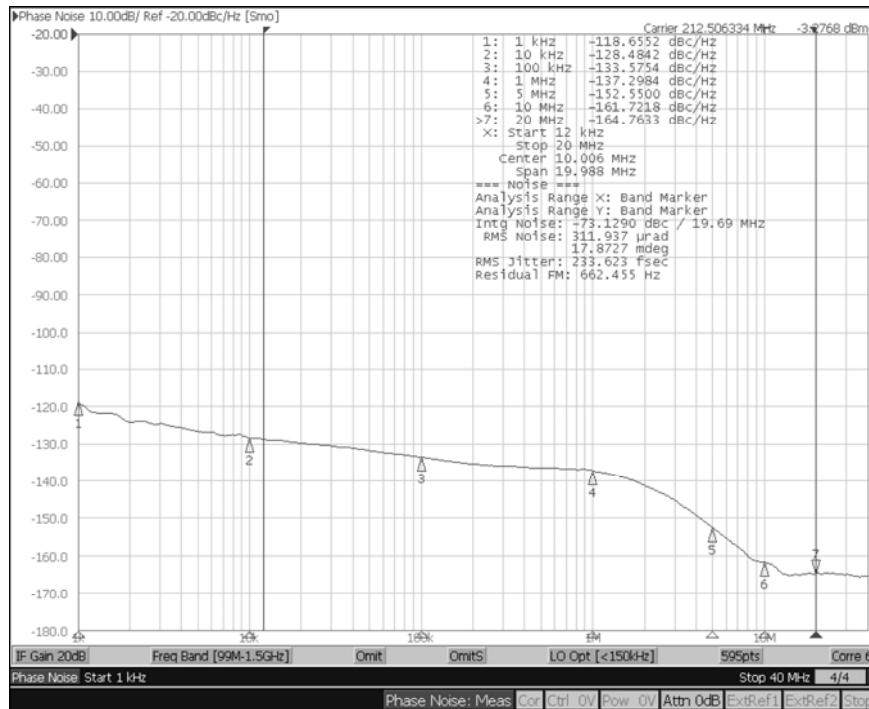

Phase Noise Plot: 212.5MHz, 12kHz – 20MHz 234fS

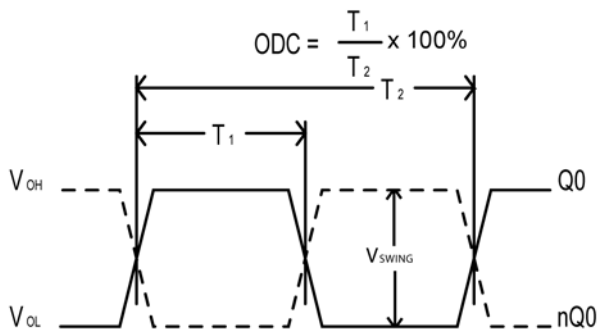

Figure 1. Duty Cycle Timing

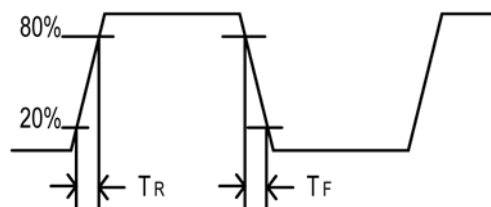

Figure 2. All Outputs Rise/Fall Time

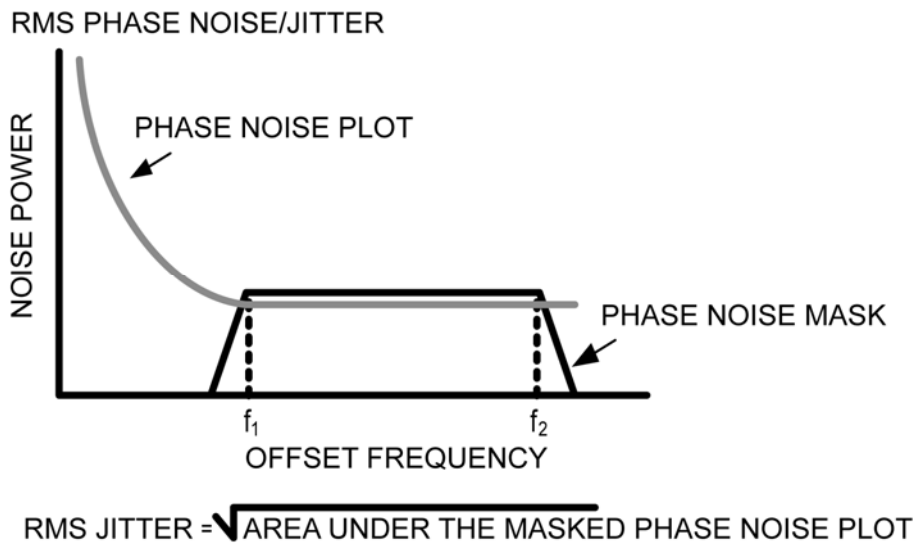

Figure 3. RMS Phase/Noise Jitter

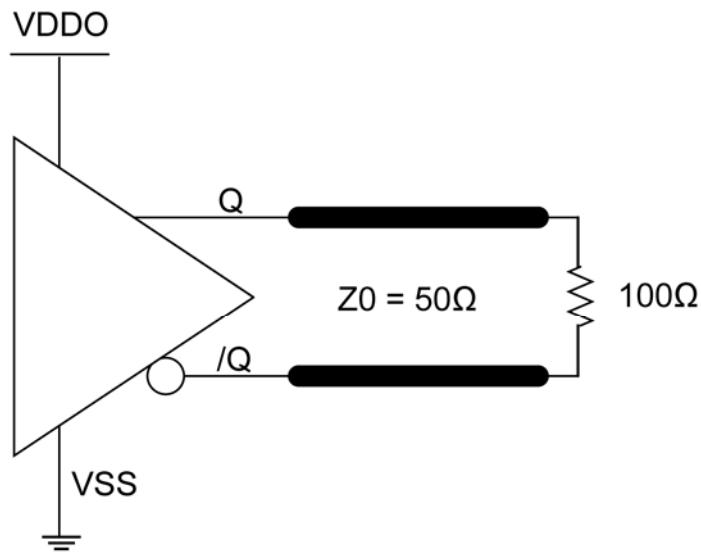

Figure 4. LVDS Output Load and Test Circuit

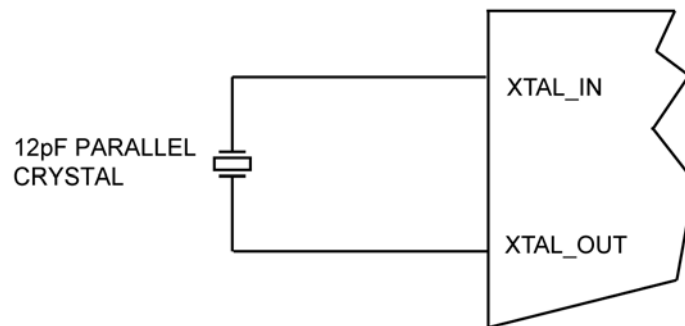
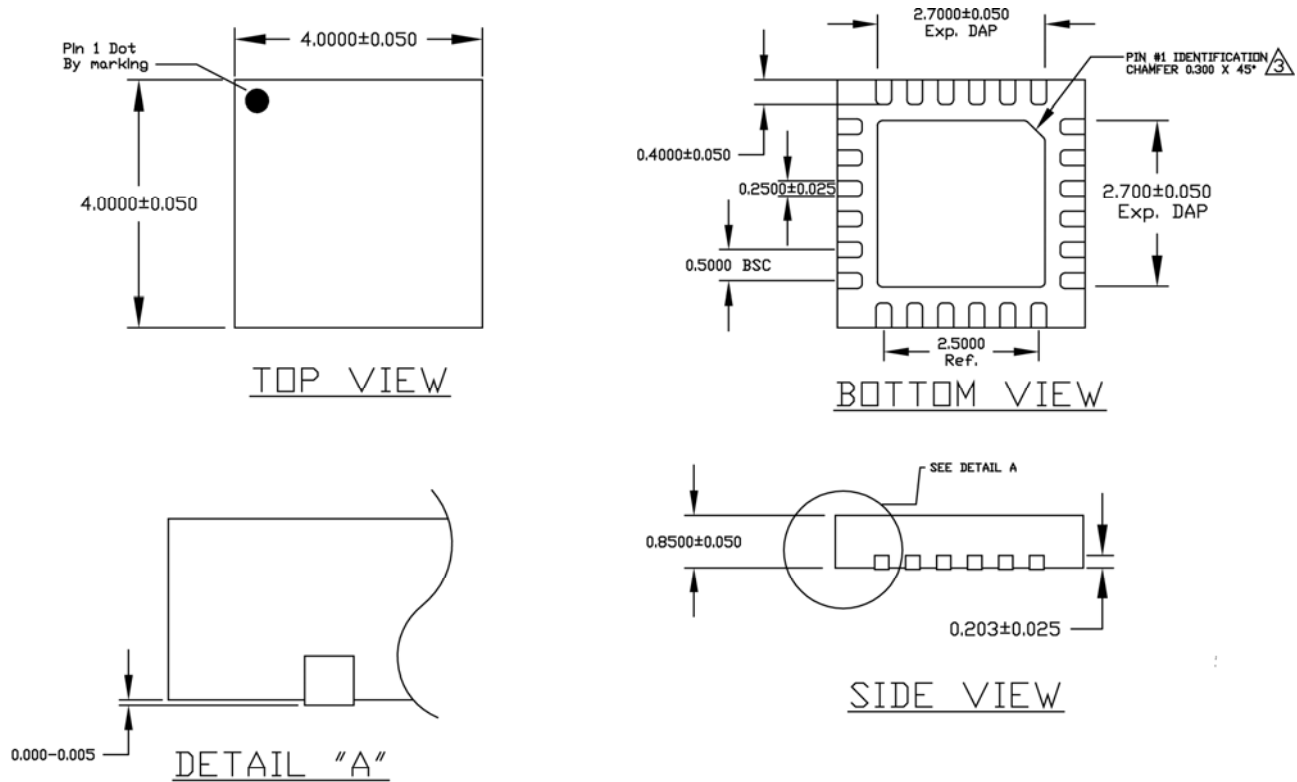

Figure 5. Crystal Input Interface

Package Information



NOTE:

1. ALL DIMENSIONS ARE IN MILLIMETERS (mm).
2. THE PIN#1 IDENTIFIER MUST EXIST ON THE TOP SURFACE OF PACKAGE BY USING IDENTIFICATION MARK OR OTHER FEATURE OF PACKAGE BODY.

CHAMFER STYLE PIN 1 IDENTIFIER ON BOTTOM SIDE

24-Pin Package Type

MICREL, INC. 2180 FORTUNE DRIVE SAN JOSE, CA 95131 USA
 TEL +1 (408) 944-0800 FAX +1 (408) 474-1000 WEB <http://www.micrel.com>

Micrel makes no representations or warranties with respect to the accuracy or completeness of the information furnished in this data sheet. This information is not intended as a warranty and Micrel does not assume responsibility for its use. Micrel reserves the right to change circuitry, specifications and descriptions at any time without notice. No license, whether express, implied, arising by estoppel or otherwise, to any intellectual property rights is granted by this document. Except as provided in Micrel's terms and conditions of sale for such products, Micrel assumes no liability whatsoever, and Micrel disclaims any express or implied warranty relating to the sale and/or use of Micrel products including liability or warranties relating to fitness for a particular purpose, merchantability, or infringement of any patent, copyright or other intellectual property right.

Micrel Products are not designed or authorized for use as components in life support appliances, devices or systems where malfunction of a product can reasonably be expected to result in personal injury. Life support devices or systems are devices or systems that (a) are intended for surgical implant into the body or (b) support or sustain life, and whose failure to perform can be reasonably expected to result in a significant injury to the user. A Purchaser's use or sale of Micrel Products for use in life support appliances, devices or systems is a Purchaser's own risk and Purchaser agrees to fully indemnify Micrel for any damages resulting from such use or sale.

© 2011 Micrel, Incorporated.



Стандарт Электрон Связь

Мы молодая и активно развивающаяся компания в области поставок электронных компонентов. Мы поставляем электронные компоненты отечественного и импортного производства напрямую от производителей и с крупнейших складов мира.

Благодаря сотрудничеству с мировыми поставщиками мы осуществляем комплексные и плановые поставки широчайшего спектра электронных компонентов.

Собственная эффективная логистика и склад в обеспечивает надежную поставку продукции в точно указанные сроки по всей России.

Мы осуществляем техническую поддержку нашим клиентам и предпродажную проверку качества продукции. На все поставляемые продукты мы предоставляем гарантию .

Осуществляем поставки продукции под контролем ВП МО РФ на предприятия военно-промышленного комплекса России , а также работаем в рамках 275 ФЗ с открытием отдельных счетов в уполномоченном банке. Система менеджмента качества компании соответствует требованиям ГОСТ ISO 9001.

Минимальные сроки поставки, гибкие цены, неограниченный ассортимент и индивидуальный подход к клиентам являются основой для выстраивания долгосрочного и эффективного сотрудничества с предприятиями радиоэлектронной промышленности, предприятиями ВПК и научно-исследовательскими институтами России.

С нами вы становитесь еще успешнее!

Наши контакты:

Телефон: +7 812 627 14 35

Электронная почта: sales@st-electron.ru

Адрес: 198099, Санкт-Петербург,
Промышленная ул, дом № 19, литера Н,
помещение 100-Н Офис 331