

# Future Technology Devices International Ltd

## FT232H Single Channel Hi-Speed USB to Multipurpose UART/FIFO IC

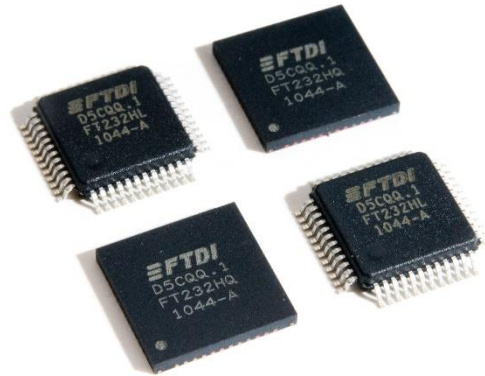

The FT232H is a single channel USB 2.0 Hi-Speed (480Mb/s) to UART/FIFO IC. It has the capability of being configured in a variety of industry standard serial or parallel interfaces. The FT232H has the following advanced features:

- Single channel USB to serial / parallel ports with a variety of configurations.
- Entire USB protocol handled on the chip. No USB specific firmware programming required.
- USB 2.0 Hi-Speed (480Mbits/Second) and Full Speed (12Mbits/Second) compatible.
- Multi-Protocol Synchronous Serial Engine (MPSSE) to simplify synchronous serial protocol (USB to JTAG, I<sup>2</sup>C, SPI (MASTER) or bit-bang) design.
- UART transfer data rate up to 12Mbaud. (RS232 Data Rate limited by external level shifter).
- USB to asynchronous 245 FIFO mode for transfer data rate up to 8 Mbyte/Sec.
- USB to synchronous 245 parallel FIFO mode for transfers up to 40 Mbytes/Sec
- Supports a proprietary half duplex FT1248 interface with a configurable width, bi-directional data bus (1, 2, 4 or 8 bits wide).
- CPU-style FIFO interface mode simplifies CPU interface design.
- Fast serial interface option.
- FTDI's royalty-free Virtual Com Port (VCP) and Direct (D2XX) drivers eliminate the requirement for USB driver development in most cases.
- Adjustable receive buffer timeout.
- Option for transmit and receive LED drive signals.
- Bit-bang Mode interface option with RD# and WR# strobes
- Highly integrated design includes 5V to 3.3/+1.8V LDO regulator for V<sub>CORE</sub>, integrated POR function
- Asynchronous serial UART interface option with full hardware handshaking and modem interface signals.
- Fully assisted hardware or X-On / X-Off software handshaking.
- UART Interface supports 7/8 bit data, 1/2 stop bits, and Odd/Even/Mark/Space/No Parity.
- Auto transmit enable control for RS485 serial applications using the TXDEN pin.
- Operational mode configuration and USB Description strings configurable in external EEPROM over the USB interface.
- Configurable I/O drives strength (4, 8, 12 or 16mA) and slew rate.
- Low operating and USB suspend current.
- Supports self-powered, bus powered and high-power bus powered USB configurations.
- UHCI/OHCI/EHCI host controller compatible.
- USB Bulk data transfer mode (512 byte packets in Hi-Speed mode).
- +1.8V (chip core) and +3.3V I/O interfacing (+5V Tolerant).
- Extended -40°C to 85°C industrial operating temperature range.
- Compact 48-pin Lead Free LQFP or QFN package
- Configurable ACBUS I/O pins.

Neither the whole nor any part of the information contained in, or the product described in this manual, may be adapted or reproduced in any material or electronic form without the prior written consent of the copyright holder. This product and its documentation are supplied on an as-is basis and no warranty as to their suitability for any particular purpose is either made or implied. Future Technology Devices International Ltd will not accept any claim for damages howsoever arising as a result of use or failure of this product. Your statutory rights are not affected. This product or any variant of it is not intended for use in any medical appliance, device or system in which the failure of the product might reasonably be expected to result in personal injury. This document provides preliminary information that may be subject to change without notice. No freedom to use patents or other intellectual property rights is implied by the publication of this document. Future Technology Devices International Ltd, Unit 1, 2 Seaward Place, Centurion Business Park, Glasgow G41 1HH United Kingdom. Scotland Registered Company Number: SC136640

## 1 Typical Applications

- Single chip USB to UART (RS232, RS422 or RS485)
- USB to FIFO
- USB to FT1248
- USB to JTAG
- USB to SPI
- USB to I<sup>2</sup>C
- USB to Bit-Bang
- USB to Fast Serial Interface
- USB to CPU target interface (as memory)
- USB Instrumentation
- USB Industrial Control
- USB EPOS Control
- USB MP3 Player Interface
- USB FLASH Card Reader / Writers
- Set Top Box - USB interface
- USB Digital Camera Interface
- USB Bar Code Readers

### 1.1 Driver Support

The FT232H requires USB device drivers (listed below), available free from <http://www.ftdichip.com>, to operate. The VCP version of the driver creates a Virtual COM Port allowing legacy serial port applications to operate over USB e.g. serial emulator application TTY. Another FTDI USB driver, the D2XX driver, can also be used with application software to directly access the FT232H through a DLL.

#### **Royalty free VIRTUAL COM PORT (VCP) DRIVERS for...**

- Windows 10 and Windows 10 64-bit
- Windows 8 and Windows 8 64-bit
- Windows 7 and Windows 7 64-bit
- Windows Vista and Vista 64-bit
- Windows XP and XP 64-bit
- Windows XP Embedded
- Windows 2000, Server 2003, Server 2008
- Windows CE 4.2, 5.0, 5.2 and 6.0
- Mac OS-X
- Linux (2.6.39 or later)

#### **Royalty free D2XX Direct Drivers (USB Drivers + DLL S/W Interface)**

- Windows 10 and Windows 10 64-bit
- Windows 8 and Windows 8 64-bit
- Windows 7 and Windows 7 64-bit
- Windows Vista and Vista 64-bit
- Windows XP and XP 64-bit
- Windows XP Embedded
- Windows 2000, Server 2003, Server 2008
- Windows CE 4.2, 5.0, 5.2 and 6.0
- Mac OS-X
- Linux (2.6.32 or later)

## 1.2 Part Numbers

Part Number	Package
FT232HL -xxxx	48 Pin LQFP
FT232HQ-xxxx	48 Pin QFN

**Note:** Packaging codes for xxxx is:

- Reel: Taped and Reel (LQFP = 1500 pieces per reel, QFN = 3000 pieces per reel)
- Tray: Tray packing, (LQFP = 250 pieces per tray, QFN = 260 pieces per tray)

Please refer to section 8 for all package mechanical parameters.

## 1.3 USB Compliant

The FT232H is fully compliant with the USB 2.0 specification and has been given the USB-IF Test-ID (TID) 40770005.

The timing of the rise/fall time of the USB signals is not only dependant on the USB signal drivers, it is also dependant system and is affected by factors such as PCB layout, external components and any transient protection present on the USB signals. For USB compliance these may require a slight adjustment. This timing can be modified through a programmable setting stored in the same external EEPROM that is used for the USB descriptors. Timing can also be changed by adding appropriate passive components to the USB signals.



## 2 FT232H Block Diagram

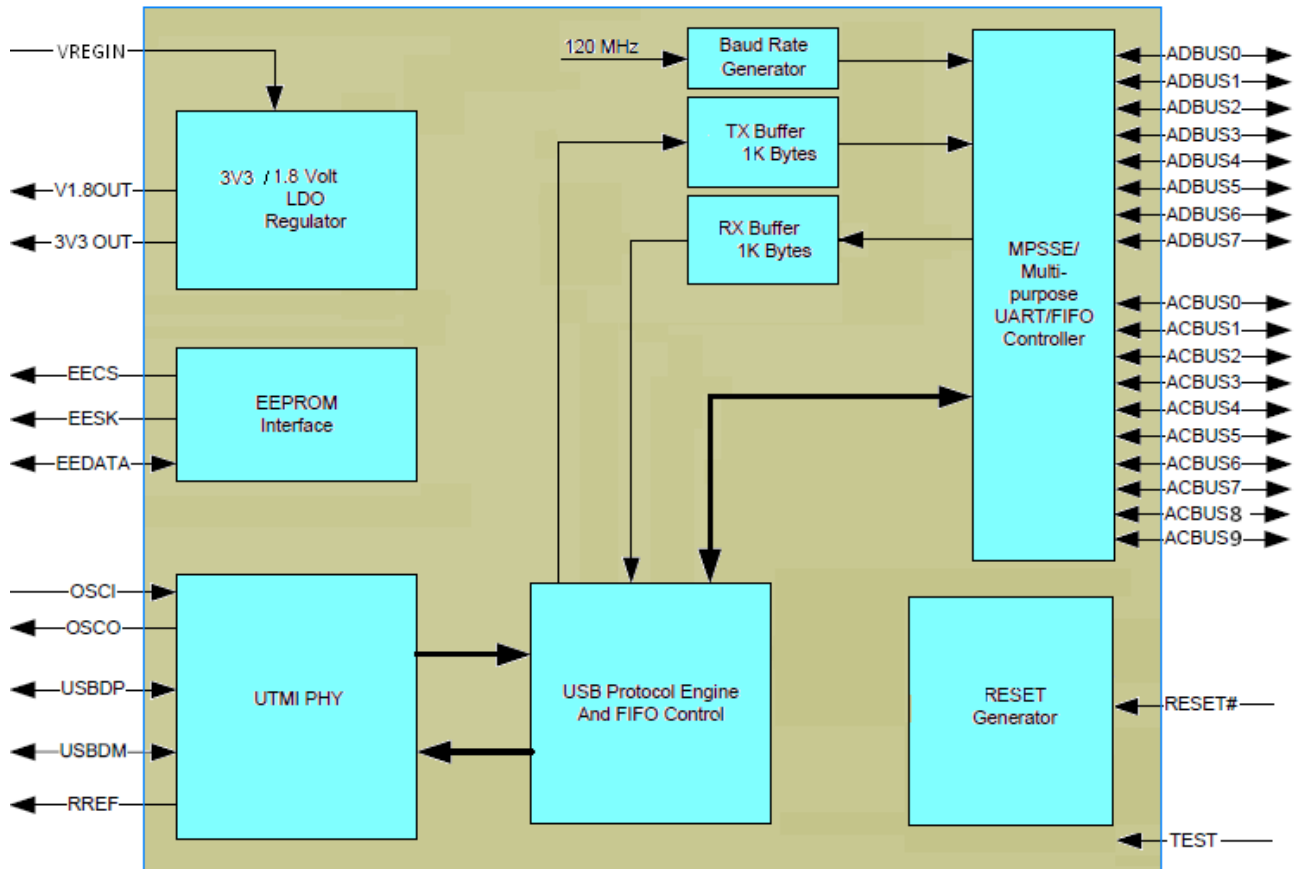

**Figure 2.1 FT232H Block Diagram**

A full description of each function is available in section 4.

## **Table of Contents**

<b>1</b>	<b>Typical Applications.....</b>	<b>2</b>
1.1	Driver Support .....	2
1.2	Part Numbers.....	3
1.3	USB Compliant .....	3
<b>2</b>	<b>FT232H Block Diagram .....</b>	<b>4</b>
<b>3</b>	<b>Device Pin Out and Signal Descriptions .....</b>	<b>8</b>
3.1	Schematic Symbol.....	8
3.2	FT232H Pin Descriptions .....	9
3.3	Signal Description .....	10
3.4	ACBUS Signal Option.....	12
3.5	Pin Configurations .....	13
3.5.1	FT232H pins used in an UART interface .....	13
3.5.2	FT232H Pins used in an FT245 Synchronous FIFO Interface .....	13
3.5.3	FT232H Pins used in an FT245 Style Aynchronous FIFO Interface .....	14
3.5.4	FT232H Configured as a Synchronous or Asynchronous Bit-Bang Interface .....	15
3.5.5	FT232H Pins used in an MPSSE .....	15
3.5.6	FT232H Pins used as a Fast Serial Interface.....	16
3.5.7	FT232H Pins Configured as a CPU-style FIFO Interface.....	17
3.5.8	FT232H Pins Configured as a FT1248 Interface .....	17
<b>4</b>	<b>Function Description .....</b>	<b>18</b>
4.1	Key Features.....	18
4.2	Functional Block Descriptions .....	19
4.3	FT232 UART Interface Mode Description.....	20
4.3.1	RS232 Configuration.....	20
4.3.2	RS422 Configuration.....	21
4.3.3	RS485 Configuration.....	22
4.4	FT245 Synchronous FIFO Interface Mode Description.....	23
4.4.1	FT245 Synchronous FIFO Read Operation.....	24
4.4.2	FT245 Synchronous FIFO Write Operation .....	24
4.5	FT245 Style Asynchronous FIFO Interface Mode Description ...	25
4.6	FT1248 Interface Mode Description .....	26
4.6.1	Bus Width Protocol Decode.....	27
4.6.2	FT1248: 1-bit interface .....	28
4.7	Synchronous and Asynchronous Bit-Bang Interface Mode .....	29

4.7.1	Asynchronous Bit-Bang Mode.....	29
4.7.2	Synchronous Bit-Bang Mode .....	29
<b>4.8</b>	<b>MPSSE Interface Mode Description .....</b>	<b>31</b>
4.8.1	MPSSE Adaptive Clocking .....	32
<b>4.9</b>	<b>Fast Serial Interface Mode Description .....</b>	<b>33</b>
4.9.1	Outgoing Fast Serial Data .....	34
4.9.2	Incoming Fast Serial Data .....	34
4.9.3	Fast Serial Data Interface Example.....	35
<b>4.10</b>	<b>CPU-style FIFO Interface Mode Description.....</b>	<b>35</b>
<b>4.11</b>	<b>RS232 UART Mode LDE Interface Description.....</b>	<b>37</b>
<b>4.12</b>	<b>Send Immediate/Wake Up (SIWU#) .....</b>	<b>38</b>
<b>4.13</b>	<b>FT232H Mode Selection .....</b>	<b>39</b>
<b>4.14</b>	<b>Modes Configuration .....</b>	<b>39</b>
<b>5</b>	<b>Devices Characteristics and Ratings .....</b>	<b>40</b>
5.1	Absolute Maximum Ratings.....	40
5.2	DC Characteristics.....	40
5.3	ESD Tolerance.....	42
<b>6</b>	<b>FT232H Configurations .....</b>	<b>43</b>
6.1	USB Bus Powered Configuration .....	43
6.2	USB Self Powered Configuration .....	44
6.2.1	Self-Powered Application Example 1 .....	44
6.2.2	Self-Powered Application Example 2 .....	45
6.3	Oscillator Configuration .....	46
<b>7</b>	<b>EEPROM Configuration.....</b>	<b>47</b>
7.1	EEPROM Interface.....	47
7.2	Default EEPROM Configuration.....	47
<b>8</b>	<b>Package Parameters.....</b>	<b>49</b>
8.1	FT232HQ, QFN-48 Package Dimensions .....	49
8.2	FT232HL, LQFP-48 Package Dimensions .....	50
8.3	Solder Reflow Profile .....	51
<b>9</b>	<b>Contact Information .....</b>	<b>53</b>
<b>Appendix A – References .....</b>	<b>54</b>	
Document References .....	54	
Acronyms and Abbreviations.....	54	



<b>Appendix B – List of Figures and Tables.....</b>	<b>55</b>
<b>List of Tables.....</b>	<b>55</b>
<b>List of Figures .....</b>	<b>56</b>
<b>Appendix C – Revision History .....</b>	<b>57</b>

### 3 Device Pin Out and Signal Descriptions

The 48-pin LQFP and 48-pin QFN have the same pin numbering for specific functions. This pin numbering is illustrated in the schematic symbol shown in Figure 3.1.

#### 3.1 Schematic Symbol

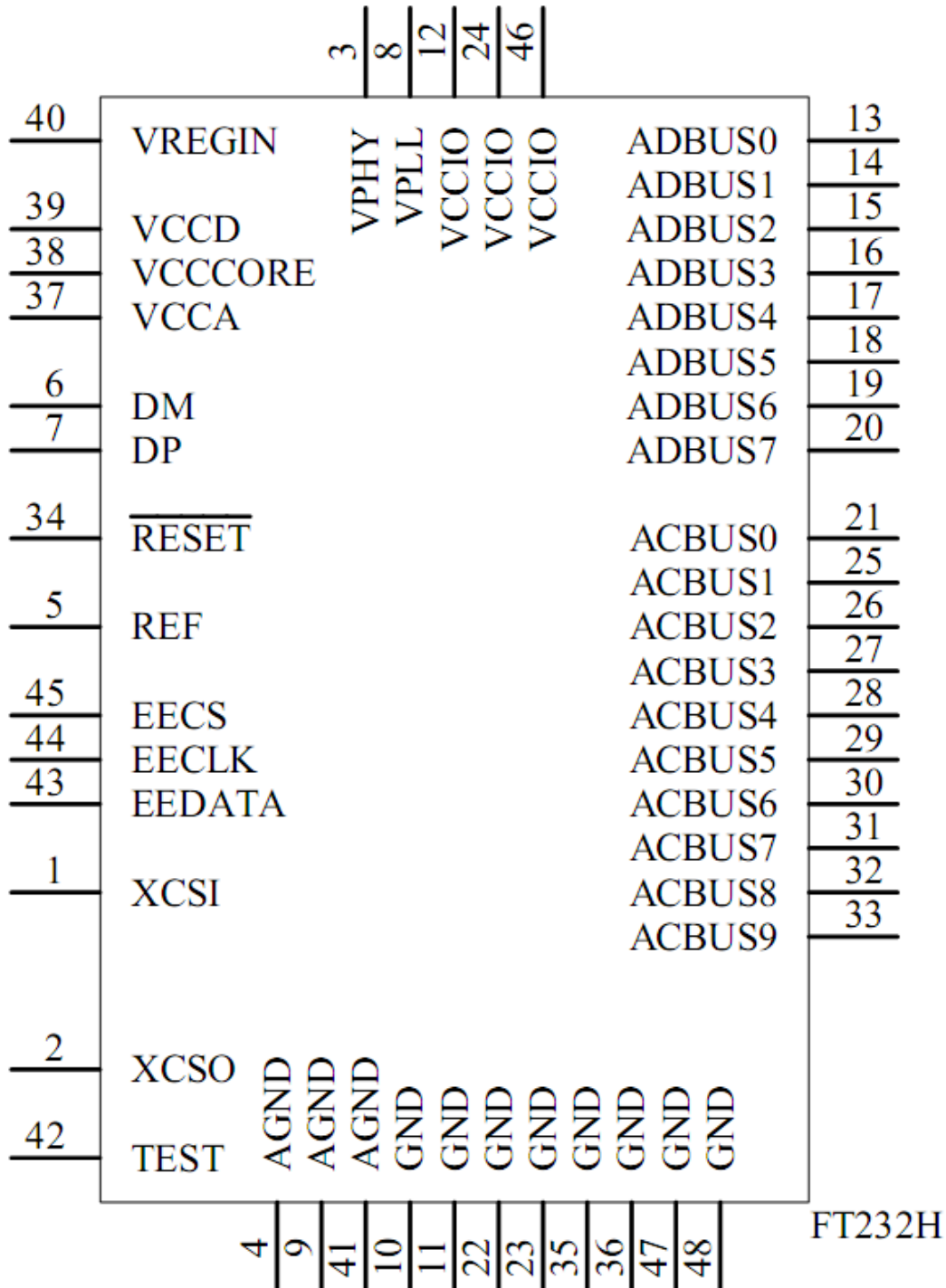

**Figure 3.1 FT232H Schematic Symbol**



### 3.2 FT232H Pin Descriptions

This section describes the operation of the FT232H pins. Both the LQFP and the QFN packages have the same function on each pin. The function of many pins is determined by the configuration of the FT232H. The following table details the function of each pin dependent on the configuration of the interface. Each of the functions is described in the following table (Note: The convention used throughout this document for active low signals is the signal name followed by #).

FT232H										
Pin		Pin functions (depends on configuration)								
Pin #	Pin Name	ASYNC Serial (RS232)	SYNC 245 FIFO	STYLE ASYNC 245 FIFO	ASYNC Bit-bang	SYNC Bit-bang	MPSSE	Fast Serial interface	CPU Style FIFO	FT1248
13	ADBUS_0	TXD	D0	D0	D0	D0	TCK/SK	FSDI	D0	MIOSI0
14	ADBUS_1	RXD	D1	D1	D1	D1	TDI/DO	FSCLK	D1	MIOSI1
15	ADBUS_2	RTS#	D2	D2	D2	D2	TDO/DI	FSDO	D2	MIOSI2
16	ADBUS_3	CTS#	D3	D3	D3	D3	TMS/CS	FSCTS	D3	MIOSI3
17	ADBUS_4	DTR#	D4	D4	D4	D4	GPIOL0	** TriSt-UP	D4	MIOSI4
18	ADBUS_5	DSR#	D5	D5	D5	D5	GPIOL1	** TriSt-UP	D5	MIOSI5
19	ADBUS_6	DCD#	D6	D6	D6	D6	GPIOL2	** TriSt-UP	D6	MIOSI6
20	ADBUS_7	RI#	D7	D7	D7	D7	GPIOL3	** TriSt-UP	D7	MIOSI7
21	ACBUS_0	* TXDEN	RXF#	RXF#	ACBUS0	ACBUS0	GPIOH0	** ACBUS0	CS#	SCLK
25	ACBUS_1	** ACBUS1	TXE#	TXE#	WRSTB#	WRSTB#	GPIOH1	** ACBUS1	A0	SS_n
26	ACBUS_2	** ACBUS2	RD#	RD#	RDSTB#	RDSTB#	GPIOH2	** ACBUS2	RD#	MISO
27	ACBUS_3	* RXLED#	WR#	WR#	ACBUS3	ACBUS3	GPIOH3	** ACBUS3	WR#	ACBUS3
28	ACBUS_4	* TXLED#	SIWU#	SIWU#	SIWU#	SIWU#	GPIOH4	SIWU#	SIWU#	ACBUS4
29	ACBUS_5	** ACBUS5	CLKOUT	ACBUS5	** ACBUS5	** ACBUS5	GPIOH5	** ACBUS5	** ACBUS5	ACBUS5
30	ACBUS_6	** ACBUS6	OE#	ACBUS6	ACBUS6	ACBUS6	GPIOH6	** ACBUS6	** ACBUS6	ACBUS6
31	ACBUS_7	WRSVAV#	PWRSVAV#	PWRSVAV#	PWRSVAV#	PWRSVAV#	*** GPIOH7	PWRSVAV#	PWRSVAV#	PWRSVAV#
32	ACBUS_8	** ACBUS8	** ACBUS8	** ACBUS8	** ACBUS8	** ACBUS8	** ACBUS8	** ACBUS8	** ACBUS8	ACBUS8
33	ACBUS_9	** ACBUS9	** ACBUS9	** ACBUS9	** ACBUS9	** ACBUS9	** ACBUS9	** ACBUS9	** ACBUS9	ACBUS9

Pins marked \* require an EEPROM for assignment to these functions. Default is Tristate, Pull-Up

Pins marked \*\* default to tri-stated inputs with an internal 75KΩ (approx.) pull up resistor to VCCIO.

Pin marked \*\*\* default to GPIO line with an internal 75KΩ pull down resistor to GND. Using the EEPROM this pin can be enabled USBVCC mode instead of GPIO mode.

### 3.3 Signal Description

The operation of the following FT232H pins are the same regardless of the configured mode:-

Pin No.	Name	Type	Description
40	** VREGIN	POWER input	+5.0V or 3V3 power supply input.
37	VCCA	POWER output	+1.8V output. Should not be used. Terminate with 0.1uF capacitor to GND
38	VCORE	POWER output	+1.8V output. Should not be used. Terminate with a 0.1uF capacitor to GND
39	** VCCD	POWER output or input	+3.3V output or input.
12, 24, 46	VCCIO	POWER input	+3.3V input. I/O interface power supply input
8	VPLL	POWER Input	+3.3V input. Internal PLL power supply input. It is recommended that this supply is filtered using an LC filter. (See figure 6.1)
3	VPHY	POWER Input	+3.3V input. Internal USB PHY power supply input. Note that this cannot be connected directly to the USB supply. A +3.3V regulator must be used. It is recommended that this supply is filtered using an LC filter.(See figure 6.1)
4,9,41	AGND	POWER Input	0V Ground input.
10,11,22,23,35,36,47,48	GND	POWER Input	0V Ground input.

**Table 3.1 Power and Ground**

\*\* If pin 40 (VREGIN) is +5.0V, pin 39 becomes an output and If pin 40 (VREGIN) is 3V3 pin 39 becomes an input.

Pin No.	Name	Type	Description
1	OSCI	INPUT	Oscillator input.
2	OSCO	OUTPUT	Oscillator output.
5	REF	INPUT	Current reference – connect via a 12KΩ resistor @ 1% to GND.
6	DM	I/O	USB Data Signal Minus.
7	DP	I/O	USB Data Signal Plus.
42	TEST	INPUT	IC test pin – for normal operation must be connected to GND.
34	RESET#	INPUT	Reset input (active low).
31	PWRSV#	INPUT	USB Power Save input. This is an EEPROM configurable option which is set using a 'Suspend on ACBus7 Low' bit in FT_PROG. This option is available when the FT232H is on a self-powered mode and is used to prevent forcing current down the USB lines when the host or hub is powered off. PWRSV# = 1 : Normal Operation PWRSV# = 0 : FT232H forced into SUSPEND mode. PWRSV# can be connected to VBUS of the USB connector (via a 39KΩ resistor). When this input goes high, then it indicates to the FT232H that it is connected to a host PC. When the host or hub is powered down then the FT232H is held in SUSPEND mode.

**Table 3.2 Common Function Pins**

Pin No.	Name	Type	Description
45	EECS	I/O	EEPROM – Chip Select. Tri-State during device reset.
44	EECLK	OUTPUT	Clock signal to EEPROM. Tri-State during device reset. When not in reset, this outputs the EEPROM clock.
43	EEDATA	I/O	EEPROM – Data I/O. Connect directly to Data-in of the EEPROM and to Data-out of the EEPROM via a 2.2K resistor. Also, pull Data-Out of the EEPROM to VCCD via a 10K resistor for correct operation. Tri-State during device reset.

**Table 3.3 EEPROM Interface Group**

Pin No.	Name	Type	Description
13	ADBUS0	Output	Configurable Output Pin, the default configuration is Transmit Asynchronous Data Output.
14	ADBUS1	Input	Configurable Input Pin, the default configuration is Receiving Asynchronous Data Input.
15	ADBUS2	Output	Configurable Output Pin, the default configuration is Request to Send Control Output / Handshake Signal.
16	ADBUS3	Input	Configurable Input Pin, the default configuration is Clear To Send Control Input / Handshake Signal.
17	ADBUS4	Output	Configurable Output Pin, the default configuration is Data Terminal Ready Control Output / Handshake Signal.
18	ADBUS5	Input	Configurable Input Pin, the default configuration is Data Set Ready Control Input / Handshake Signal.
19	ADBUS6	Input	Configurable Input Pin, the default configuration is Data Carrier Detect Control Input.
20	ADBUS7	Input	Configurable Input Pin, the default configuration is Ring Indicator Control Input. When remote wake up is enabled in the EEPROM taking RI# low can be used to resume the PC USB host controller from suspend. (Also see note 1, 2, 3 in section 4.12)
21	ACBUS0	I/O	Configurable ACBUS I/O Pin. Function of this pin is configured in the device EEPROM. If the external EEPROM is not fitted the default configuration is TriSt-PU. See ACBUS Signal Options, Table 3.5.
25	ACBUS1	I/O	Configurable ACBUS I/O Pin. Function of this pin is configured in the device EEPROM. If the external EEPROM is not fitted the default configuration is TriSt-PU. See ACBUS Signal Options, Table 3.5.
26	ACBUS2	I/O	Configurable ACBUS I/O Pin. Function of this pin is configured in the device EEPROM. If the external EEPROM is not fitted the default configuration is TriSt-PU. See ACBUS Signal Options, Table 3.5.
27	ACBUS3	I/O	Configurable ACBUS I/O Pin. Function of this pin is configured in the device EEPROM. If the external EEPROM is not fitted the default configuration is TriSt-PU. See ACBUS Signal Options, Table 3.5.
28	ACBUS4	I/O	Configurable ACBUS I/O Pin. Function of this pin is configured in the device EEPROM. If the external EEPROM is not fitted the default configuration is TriSt-PU. See ACBUS Signal Options, Table 3.5.
29	ACBUS5	I/O	Configurable ACBUS I/O Pin. Function of this pin is configured in the device EEPROM. If the external EEPROM is not fitted the default configuration is TriSt-PU. See ACBUS Signal Options, Table 3.5.
30	ACBUS6	I/O	Configurable ACBUS I/O Pin. Function of this pin is configured in the device EEPROM. If the external EEPROM is not fitted the default configuration is TriSt-PU. See ACBUS Signal Options, Table 3.5.
31	ACBUS7	I/O	Configurable ACBUS I/O Pin. Function of this pin is configured in the device EEPROM. If the external EEPROM is not fitted the default configuration is TriSt-PD. See ACBUS Signal Options, Table 3.5.
32	ACBUS8	I/O	Configurable ACBUS I/O Pin. Function of this pin is configured in the device EEPROM. If the external EEPROM is not fitted the default configuration is TriSt-PU. See ACBUS Signal Options, Table 3.5.
33	ACBUS9	I/O	Configurable ACBUS I/O Pin. Function of this pin is configured in the device EEPROM. If the external EEPROM is not fitted the default configuration is TriSt-PU. See ACBUS Signal Options, Table 3.5.

**Table 3.4 UART Interface and ACBUS Group (see note 1)**

**Notes:**

When used in Input Mode, the input pins are pulled to VCCIO via internal 75kΩ (approx.) resistors. These pins can be programmed to gently pull low during USB suspend (PWREN# = "1") by setting an option in the EEPROM.

### 3.4 ACBUS Signal Option

If the external EEPROM is fitted, the following options can be configured on the CBUS I/O pins using the software utility [FT\\_PROG](#) which can be downloaded from the [FTDI utilities](#) page. CBUS signal options are common to both package versions of the FT232H. The default configuration is described in section 7.

ACBUS Signal Option	Available On ACBUS Pin	Description
TXDEN	ACBUS0, ACBUS1, ACBUS2, ACBUS3, ACBUS4, ACBUS5, ACBUS6, ACBUS8, ACBUS9	TXDEN = (TTL level). Used with RS485 level converters to enable the line driver during data transmit. TXDEN is active from one bit time before the start bit is transmitted on TXD until the end of the stop bit.
*PWREN#	ACBUS0, ACBUS1, ACBUS2, ACBUS3, ACBUS4, ACBUS5, ACBUS6, ACBUS8, ACBUS9	Output is low after the device has been configured by USB, then high during USB suspend mode. This output can be used to control power to external logic P-Channel logic level MOSFET switch. Enable the interface pull-down option when using the PWREN# in this way.*
TXLED#	ACBUS0, ACBUS1, ACBUS2, ACBUS3, ACBUS4, ACBUS5, ACBUS6, ACBUS8, ACBUS9	TXLED = Transmit signalling output. Pulses low when transmitting data (TXD) to the external device. This can be connected to an LED.
RXLED#	ACBUS0, ACBUS1, ACBUS2, ACBUS3, ACBUS4, ACBUS5, ACBUS6, ACBUS8, ACBUS9	RXLED = Receive signalling output. Pulses low when receiving data (RXD) from the external device. This can be connected to an LED.
TX&RXLED#	ACBUS0, ACBUS1, ACBUS2, ACBUS3, ACBUS4, ACBUS5, ACBUS6, ACBUS8, ACBUS9	LED drive – pulses low when transmitting or receiving data from or to the external device.
SLEEP#	ACBUS0, ACBUS1, ACBUS2, ACBUS3, ACBUS4, ACBUS5, ACBUS6, ACBUS8, ACBUS9	Goes low during USB suspend mode. Typically used to power down an external TTL to RS232 level converter IC in USB to RS232 converter designs.
**CLK30	ACBUS0, ACBUS5, ACBUS6, ACBUS8, ACBUS9	30MHz Clock output.
**CLK15	ACBUS0, ACBUS5, ACBUS6, ACBUS8, ACBUS9	15MHz Clock output.
**CLK7.5	ACBUS0, ACBUS5, ACBUS6, ACBUS8, ACBUS9	7.5MHz Clock output.
TriSt-PU	ACBUS0, ACBUS1, ACBUS2, ACBUS3, ACBUS4, ACBUS5, ACBUS6, ACBUS8, ACBUS9	Input Pull Up
DRIVE 1	ACBUS0, ACBUS5, ACBUS6, ACBUS8, ACBUS9	Output High
DRIVE 0	ACBUS0, ACBUS1, ACBUS2, ACBUS3, ACBUS4, ACBUS5, ACBUS6, ACBUS8, ACBUS9	Output Low
I/O mode	ACBUS5, ACBUS6, ACBUS8, ACBUS9	ACBUS Bit Bang

**Table 3.5 ACBUS Configuration Control**

\* Must be used with a 10kΩ resistor pull up.

\*\*When in USB suspend mode the outputs clocks are also suspended.

### 3.5 Pin Configurations

The following section describes the function of the pins when the device is configured in different modes of operation.

#### 3.5.1 FT232H pins used in an UART interface

The FT232H can be configured as a UART interface. When configured in this mode, the pins used and the descriptions of the signals are shown in Table 3.6.

Pin No.	Name	Type	UART Configuration Description
13	TXD	OUTPUT	TXD = transmitter output
14	RXD	INPUT	RXD = receiver input
15	RTS#	OUTPUT	RTS# = Ready To send handshake output
16	CTS#	INPUT	CTS# = Clear To Send handshake input
17	DTR#	OUTPUT	DTR# = Data Transmit Ready modem signalling line
18	DSR#	INPUT	DSR# = Data Set Ready modem signalling line
19	DCD#	INPUT	DCD# = Data Carrier Detect modem signalling line
20	RI#	INPUT	RI# = Ring Indicator Control Input. When the Remote Wake up option is enabled in the EEPROM, taking RI# low can be used to resume the PC USB Host controller from suspend.
21	** TXDEN	OUTPUT	TXDEN = (TTL level). Use to enable RS485 level converter
27	** RXLED	OUTPUT	RXLED = Receive signalling output. Pulses low when receiving data (RXD) from the external device (UART Interface). This should be connected to an LED.
28	** TXLED	OUTPUT	TXLED = Transmit signalling output. Pulses low when transmitting data (TXD) to the external device (UART Interface). This should be connected to an LED.

**Table 3.6 UART Configured Pin Descriptions**

\*\* ACBUS I/O pins

For a functional description of this mode, please refer to section 4.3

**Note:** UART is the device default mode.

#### 3.5.2 FT232H Pins used in an FT245 Synchronous FIFO Interface

The FT232H can be configured as a FT245 synchronous FIFO interface. When configured in this mode, the pins used and the descriptions of the signals are shown in Table 3.7. To set this mode the external EEPROM must be set to 245 modes. A software command (FT\_SetBitMode) is then sent by the application to the FTDI D2XX driver to tell the chip to enter 245 synchronous FIFO mode. In this mode, data is written or read on the rising edge of the CLKOUT. Refer to Figure 4.4 for timing details.

Pin No.	Name	Type	FT245 Configuration Description
13,14,15,16,17,18,19,20	ADBUS[7:0]	I/O	D7 to D0 bidirectional FIFO data. This bus is normally input unless OE# is low.
21	RXF#	OUTPUT	When high, do not read data from the FIFO. When low, there is data available in the FIFO which can be read by driving RD# low. When in synchronous mode, data is transferred on every clock that RXF# and RD# are both low. Note that the OE# pin must be driven low at least 1 clock period before asserting RD# low.
25	TXE#	OUTPUT	When high, do not write data into the FIFO. When low, data can be written into the FIFO by driving WR# low. When in synchronous mode, data is transferred on every clock that TXE# and WR# are

			both low.
26	RD#	INPUT	Enables the current FIFO data byte to be driven onto D0...D7 when RD# goes low. The next FIFO data byte (if available) is fetched from the receive FIFO buffer each CLKOUT cycle until RD# goes high.
27	WR#	INPUT	Enables the data byte on the D0...D7 pins to be written into the transmit FIFO buffer when WR# is low. The next FIFO data byte is written to the transmit FIFO buffer each CLKOUT cycle until WR# goes high.
28	SIWU#	INPUT	The Send Immediate / WakeUp signal combines two functions on a single pin. If USB is in suspend mode (PWREN# = 1) and remote wakeup is enabled in the EEPROM, strobing this pin low will cause the device to request a resume on the USB Bus. Normally, this can be used to wake up the Host PC. During normal operation (PWREN# = 0), if this pin is strobed low any data in the device RX buffer will be sent out over USB on the next Bulk-IN request from the drivers regardless of the pending packet size. This can be used to optimize USB transfer speed for some applications. Tie this pin to VCCIO if not used.
29	CLKOUT	OUTPUT	60 MHz Clock driven from the chip. All signals should be synchronized to this clock.
30	OE#	INPUT	Output enable when low to drive data onto D0-7. This should be driven low at least 1 clock period before driving RD# low to allow for data buffer turn-around.

**Table 3.7 FT245 Synchronous FIFO Configured Pin Descriptions**

For a functional description of this mode, please refer to section 4.4.

### 3.5.3 FT232H Pins used in an FT245 Style asynchronous FIFO Interface

The FT232H can be configured as a FT245 style asynchronous FIFO interface. When configured in this mode, the pins used and the descriptions of the signals are shown in Table 3.8. To enter this mode the external EEPROM must be set to 245 asynchronous FIFO mode. In this mode, data is written or read on the falling edge of the RD# or WR# signals.

Pin No.	Name	Type	FT245 Configuration Description
13, 14, 15, 16, 17, 18, 19, 20	ADBUS[7:0]	I/O	D7 to D0 bidirectional FIFO data. This bus is normally input unless RD# is low.
21	RXF#	OUTPUT	When high, do not read data from the FIFO. When low, there is data available in the FIFO which can be read by driving RD# low. When RD# goes high again RXF# will always go high and only become low again if there is another byte to read. During reset this signal pin is tristate, but pulled up to VCCIO via an internal 200kΩ resistor.
25	TXE#	OUTPUT	When high, do not write data into the FIFO. When low, data can be written into the FIFO by strobing WR# high, then low. During reset this signal pin is tristate, but pulled up to VCCIO via an internal 200kΩ resistor.
26	RD#	INPUT	Enables the current FIFO data byte to be driven onto D0...D7 when RD# goes low. Fetches the next FIFO data byte (if available) from the receive FIFO buffer when RD# goes high.
27	WR#	INPUT	Writes the data byte on the D0...D7 pins into the transmit FIFO buffer when WR# goes from high to low.
	SIWU#	INPUT	The Send Immediate / WakeUp signal combines two functions on a single pin. If USB is in suspend mode

28			(PWREN# = 1) and remote wakeup is enabled in the EEPROM, strobing this pin low will cause the device to request a resume on the USB Bus. Normally, this can be used to wake up the Host PC. During normal operation (PWREN# = 0), if this pin is strobed low any data in the device RX buffer will be sent out over USB on the next Bulk-IN request from the drivers regardless of the pending packet size. This can be used to optimize USB transfer speed for some applications. Tie this pin to VCCIO if not used.
----	--	--	--

**Table 3.8 FT245 Style Asynchronous FIFO Configured Pin Descriptions**

For a functional description of this mode, please refer to section 4.5.

### 3.5.4 FT232H Configured as a Synchronous or Asynchronous Bit-Bang Interface

Bit-bang mode is an FTDI FT232H device mode that changes the 8 IO lines into an 8 bit bi-directional data bus. This mode is enabled by sending a software command (FT\_SetBitMode) to the FTDI driver. When configured in any bit-bang mode, the pins used and the descriptions of the signals are shown in Table 3.9

Pin No.	Name	Type	Configuration Description
13,14,15,16,17,18,19,20	ADBUS[7:0]	I/O	D7 to D0 bidirectional Bit-Bang parallel I/O data pins
25	WRSTB#	OUTPUT	Write strobe, active low output indicates when new data has been written to the I/O pins from the Host PC (via the USB interface).
26	RDSTB#	OUTPUT	Read strobe, this output rising edge indicates when data has been read from the parallel I/O pins and sent to the Host PC (via the USB interface).
28	SIWU#	INPUT	The Send Immediate / WakeUp signal combines two functions on a single pin. If USB is in suspend mode (PWREN# = 1) and remote wakeup is enabled in the EEPROM, strobing this pin low will cause the device to request a resume on the USB Bus. Normally, this can be used to wake up the Host PC. During normal operation (PWREN# = 0), if this pin is strobed low any data in the device RX buffer will be sent out over USB on the next Bulk-IN request from the drivers regardless of the pending packet size. This can be used to optimize USB transfer speed for some applications. Tie this pin to VCCIO if not used.

**Table 3.9 Synchronous or Asynchronous Bit-Bang Configured Pin Descriptions**

For functional description of this mode, please refer to section 4.6.

### 3.5.5 FT232H Pins used in an MPSSE

The FT232H has a Multi-Protocol Synchronous Serial Engine (MPSSE). This mode is enabled by sending a software command (FT\_SetBitMode) to the FTDI D2xx driver. The MPSSE can be configured to a number of industry standard serial interface protocols such as JTAG, I<sup>2</sup>C or SPI (MASTER), or it can be used to implement a proprietary bus protocol. For example, it is possible to connect FT232H's to an SRAM configurable FPGA such as supplied by Altera or Xilinx. The FPGA device would normally not be configured (i.e. have no defined function) at power-up. Application software on the PC could use the MPSSE (and D2XX driver) to download configuration data to the FPGA over USB. This data would define the hardware function on power up. The MPSSE can be used to control a number of GPIO pins. When configured in this mode, the pins used and the descriptions of the signals are shown in Table 3.10

Pin No.	Name	Type	MPSSE Configuration Description
13	TCK/SK	OUTPUT	Clock Signal Output. For example: JTAG – TCK, Test interface clock

			SPI (MASTER) – SK, Serial Clock
14	TDI/DO	OUTPUT	Serial Data Output. For example: JTAG – TDI, Test Data Input SPI (MASTER) – DO
15	TDO/DI	INPUT	Serial Data Input. For example: JTAG – TDO, Test Data output SPI (MASTER) – DI, Serial Data Input
16	TMS/CS	OUTPUT	Output Signal Select. For example: JTAG – TMS, Test Mode Select SPI (MASTER) – CS, Serial Chip Select
17	GPIOL0	I/O	General Purpose input/output
18	GPIOL1	I/O	General Purpose input/output
19	GPIOL2	I/O	General Purpose input/output
20	GPIOL3	I/O	General Purpose input/output
21	GPIOH0	I/O	General Purpose input/output
25	GPIOH1	I/O	General Purpose input/output
26	GPIOH2	I/O	General Purpose input/output
27	GPIOH3	I/O	General Purpose input/output
28	GPIOH4	I/O	General Purpose input/output
29	GPIOH5	I/O	General Purpose input/output
30	GPIOH6	I/O	General Purpose input/output
31	GPIOH7	I/O	General Purpose input/output

**Table 3.10 MPSSE Configured Pin Descriptions**

For functional description of this mode, please refer to section 4.8.

### 3.5.6 FT232H Pins used as a Fast Serial Interface

The FT232H can be configured for use with high-speed bi-directional isolated serial data. A proprietary FTDI protocol designed to allow galvanic isolated devices to communicate synchronously with the FT232H using just 4 signal wires (over two dual opto-isolators), and two power lines. The peripheral circuitry controls the data transfer rate in both directions, whilst maintaining full data integrity. 12 Mbps (USB full speed) data rates can be achieved when using the proper high speed opto-isolators (see [App Note AN-131](#)). When configured in this mode, the pins used and the descriptions of the signals are shown in Table 3.11.

Pin No.	Name	Type	Fast Serial Interface Configuration Description
13	FSDI	INPUT	Fast serial data input.
14	FSCLK	INPUT	Fast serial clock input. Clock input to FT232H chip to clock data in or out.
15	FSDO	OUTPUT	Fast serial data output.
16	FSCTS	OUTPUT	Fast serial Clear To Send signal output. Driven low to indicate that the chip is ready to send data
28	SIWU#	INPUT	The Send Immediate / WakeUp signal combines two functions on a single pin. If USB is in suspend mode (PWREN# = 1) and remote wakeup is enabled in the EEPROM, strobing this pin low will cause the device to request a resume on the USB Bus. Normally, this can be used to wake up the Host PC. During normal operation (PWREN# = 0), if this pin is strobed low any data in the device RX buffer will be sent out over USB on the next Bulk-IN request from the drivers regardless of the pending packet size. This can be used to optimize USB transfer speed for some applications. Tie this pin to VCCIO if not used.

**Table 3.11 Fast Serial Interface Configured Pin Descriptions**

For a functional description of this mode, please refer to section 4.9.



### 3.5.7 FT232H Pins Configured as a CPU-style FIFO Interface

The FT232H can be configured in a CPU-style FIFO interface mode which allows a CPU to interface to USB via the FT232H. This mode is enabled in the external EEPROM. When configured in this mode, the pins used and the descriptions of the signals are shown in Table 3.12.

Pin No.	Name	Type	Fast Serial Interface Configuration Description
13, 14, 15, 16, 17, 18, 19, 20	ADBUS[7:0]	I/O	D7 to D0 bidirectional data bus
21	CS#	INPUT	Active low chip select input
25	A0	INPUT	Address bit A0
26	RD#	INPUT	Active Low FIFO Read input
27	WR#	INPUT	Active Low FIFO Write input
28	SIWU#	INPUT	Tie this pin to VCCIO if not used – otherwise, for normal operation The Send Immediate / WakeUp signal combines two functions on a single pin. If USB is in suspend mode (PWREN# = 1) and remote wakeup is enabled in the EEPROM, strobing this pin low will cause the device to request a resume on the USB Bus. Normally, this can be used to wake up the Host PC. During normal operation (PWREN# = 0), if this pin is strobed low any data in the device RX buffer will be sent out over USB on the next Bulk-IN request from the drivers regardless of the pending packet size. This can be used to optimize USB transfer speed for some applications.

**Table 3.12 CPU-style FIFO Interface Configured Pin Descriptions**

For a functional description of this mode, please refer to section 4.10.

### 3.5.8 FT232H Pins Configured as a FT1248 Interface

The FT232H can be configured as a proprietary FT1248 interface. This mode is enabled in the external EEPROM. When configured in this mode, the pins used and the descriptions of the signals are shown in Table 3.13.

Pin No.	Name	Type	UART Configuration Description
13	MIOSIO0	INPUT /OUTPUT	Bi-directional synchronous command and data bus, bit 0 used to transmit and receive data from/to the master
14	MIOSIO1	INPUT /OUTPUT	Bi-directional synchronous command and data bus, bit 1 used to transmit and receive data from/to the master
15	MIOSIO2	INPUT /OUTPUT	Bi-directional synchronous command and data bus, bit 2 used to transmit and receive data from/to the master
16	MIOSIO3	INPUT /OUTPUT	Bi-directional synchronous command and data bus, bit 3 used to transmit and receive data from/to the master
17	MIOSIO4	INPUT /OUTPUT	Bi-directional synchronous command and data bus, bit 4 used to transmit and receive data from/to the master
18	MIOSIO5	INPUT /OUTPUT	Bi-directional synchronous command and data bus, bit 5 used to transmit and receive data from/to the master
19	MIOSIO6	INPUT /OUTPUT	Bi-directional synchronous command and data bus, bit 6 used to transmit and receive data from/to the master
20	MIOSIO7	INPUT /OUTPUT	Bi-directional synchronous command and data bus, bit 7 used to transmit and receive data from/to the master
21	SCLK	INPUT	Serial clock used to drive the slave device data
25	SS_n	INPUT	Active low slave select 0 from master to slave
26	MISO	OUTPUT	Slave output used to transmit the status of the transmit and receive buffers are empty and full respectively

**Table 3.13 FT1248 Configured Pin Descriptions**

For functional description of this mode, please refer to section 4.

## 4 Function Description

The FT232H USB 2.0 Hi-Speed (480Mb/s) to UART/FIFO is an FTDI's 6<sup>th</sup> generation of ICs. It can be configured in a variety of industry standard serial or parallel interfaces, such as UART, FIFO, JTAG, SPI (MASTER) or I<sup>2</sup>C modes. In addition to these, the FT232H introduces the FT1248 interface and supports a CPU-Style FIFO mode, bit-bang and a fast serial interface mode.

### 4.1 Key Features

**USB Hi-Speed to UART/FIFO Interface.** The FT232H provides USB 2.0 Hi-Speed (480Mbits/s) to flexible and configurable UART/FIFO Interfaces.

**Functional Integration.** The FT232H integrates a USB protocol engine which controls the physical Universal Transceiver Macrocell Interface (UTMI) and handles all aspects of the USB 2.0 Hi-Speed interface. The FT232H includes an integrated +1.8V/3.3V Low Drop-Out (LDO) regulator. It also includes 1Kbytes Tx and Rx data buffers. The FT232H integrates the entire USB protocol on a chip with no firmware required.

**MPSSE.** Multi- Protocol Synchronous Serial Engines (MPSSE), capable of speeds up to 30 Mbits/s, provides flexible synchronous interface configurations.

**FT1248 interface.** The FT232H supports a new proprietary half-duplex FT1248 interface with a variable bi-directional data bus interface that can be configured as 1, 2, 4, or 8-bits wide and this enables the flexibility to expand the size of the data bus to 8 pins. For details regarding 2-bit, 4-bit and 8-bit modes, please refer to application note AN\_167\_FT1248\_Serial\_Parallel Interface Basics available from the FTDI website.

**Data Transfer rate.** The FT232H supports a data transfer rate up to 12 Mbaud when configured as an RS232/RS422/RS485 UART interface up to 40 Mbytes/second over a synchronous 245 parallel FIFO interface or up to 8 Mbyte/Sec over an asynchronous 245 FIFO interface. Please note the FT232H does not support the baud rates of 7 Mbaud 9 Mbaud, 10 Mbaud and 11 Mbaud.

**Latency Timer.** A feature of the driver used as a timeout to transmit short packets of data back to the PC. The default is 16ms, but it can be altered between 0ms and 255ms.

**Bus (ACBUS) functionality, signal inversion and drive strength selection.** There are 11 configurable ACBUS I/O pins. These configurable options are:

1. **TXDEN** – transmit enable for RS485 designs.
2. **PWREN#** - Power control for high power, bus powered designs.
3. **TXLED#** - for pulsing an LED upon transmission of data.
4. **RXLED#** - for pulsing an LED upon receiving data.
5. **TX&RXLED#** - which will pulse an LED upon transmission OR reception of data.
6. **SLEEP#** - indicates that the device going into USB suspend mode.
7. **CLK30 / CLK15 / CLK7.5** – 30MHz, 15MHz and 7.5MHz clock output signal options.
8. **TriSt-PU** – Input pulled up, not used
9. **DRIVE 1** – Output driving high
10. **DRIVE 0** – Output driving low
11. **I/O mode** – ACBUS Bit Bang

The ACBUS pins can also be individually configured as GPIO pins, similar to asynchronous bit bang mode. It is possible to use this mode while the UART interface is being used, thus providing up to 4 general purpose I/O pins which are available during normal operation.

The ACBUS lines can be configured with any one of these input/output options by setting bits in the external EEPROM see section 0.

## 4.2 Functional Block Descriptions

**Multi-Purpose UART/FIFO Controllers.** The FT232H has one independent UART/FIFO Controller. This controls the UART data, 245 FIFO data, Fast Serial (opto isolation) or Bit-Bang mode which can be selected by SETUP (FT\_SetBitMode) command. Each Multi-Purpose UART/FIFO Controller also contains an MPSSE (Multi-Protocol Synchronous Serial Engine). Using this MPSSE, the Multi-Purpose UART/FIFO Controller can be configured under software command, to have one of the MPSSE (SPI (MASTER), I<sup>2</sup>C, and JTAG).

**USB Protocol Engine and FIFO control.** The USB Protocol Engine controls and manages the interface between the UTMI PHY and the FIFOs of the chip. It also handles power management and the USB protocol specification.

**Port FIFO TX Buffer (1Kbytes).** Data from the Host PC is stored in these buffers to be used by the Multi-purpose UART/FIFO controllers. This is controlled by the USB Protocol Engine and FIFO control block.

**Port FIFO RX Buffer (1Kbytes).** Data from the Multi-purpose UART/FIFO controllers is stored in these blocks to be sent back to the Host PC when requested. This is controlled by the USB Protocol Engine and FIFO control block.

**RESET Generator** – The integrated Reset Generator Cell provides a reliable power-on reset to the device internal circuitry at power up. The RESET# input pin allows an external device to reset the FT232H. RESET# should be tied to VCCIO (+3.3V) if not being used.

**Baud Rate Generators** – The Baud Rate Generators provides an x16 or an x10 clock input to the UART's from a 120MHz reference clock and consists of a 14 bit pre-scaler and 4 register bits which provide fine tuning of the baud rate (used to divide by a number plus a fraction). This determines the Baud Rate of the UART which is programmable from 183 baud to 12 Mbaud. See FTDI application note [AN\\_120](#) on the [FTDI website](#) for more details.

**EEPROM Interface.** If the external EEPROM is fitted, the FT232H can be configured as an asynchronous serial UART (default mode), parallel FIFO (245) mode, FT1248, fast serial (opto isolation) or CPU-Style FIFO. The EEPROM should be a 16 bit wide configuration such as a 93LC56B or equivalent capable of a 1Mbit/s clock rate at VCCIO = +2.97V to 3.63V. The EEPROM is programmable in-circuit over USB using a utility program called [FT\\_Prog](#) available from [FTDI](#) web site. Please note that the 93LC46B is not compatible with the FT232H device.

**+1.8/3.3V LDO Regulator.** The +3.3/+1.8V LDO regulator generates +1.8 volts for the core and the USB transceiver cell and +3.3V for the IO and the internal PLL and USB PHY power supply.

**UTMI PHY.** The Universal Transceiver Macrocell Interface (UTMI) physical interface cell. This block handles the Full speed / Hi-Speed SERDES (serialise – deserialise) function for the USB TX/RX data. It also provides the clocks for the rest of the chip. A 12 MHz crystal must be connected to the OSCI and OSCO pins or 12 MHz Oscillator must be connected to the OSCI, and the OSCO is left unconnected. A 12K Ohm resistor should be connected between REF and GND on the PCB.

The UTMI PHY functions include:

- Supports 480 Mbit/s "Hi-Speed" (HS)/ 12 Mbit/s "Full Speed" (FS).
- SYNC/EOP generation and checking
- Data and clock recovery from serial stream on the USB.
- Bit-stuffing/unstuffing; bit stuff error detection.
- Manages USB Resume, Wake Up and Suspend functions.
- Single parallel data clock output with on-chip PLL to generate higher speed serial data clocks.

### 4.3 FT232 UART Interface Mode Description

The FT232H can be configured as a UART with external line drivers, similar to operation with the FTDI FT232R devices. The following examples illustrate how to configure the FT232H with an RS232, RS422 or RS485 interface.

#### 4.3.1 RS232 Configuration

Figure 4.1 illustrates how the FT232H can be configured with an RS232 UART interface.

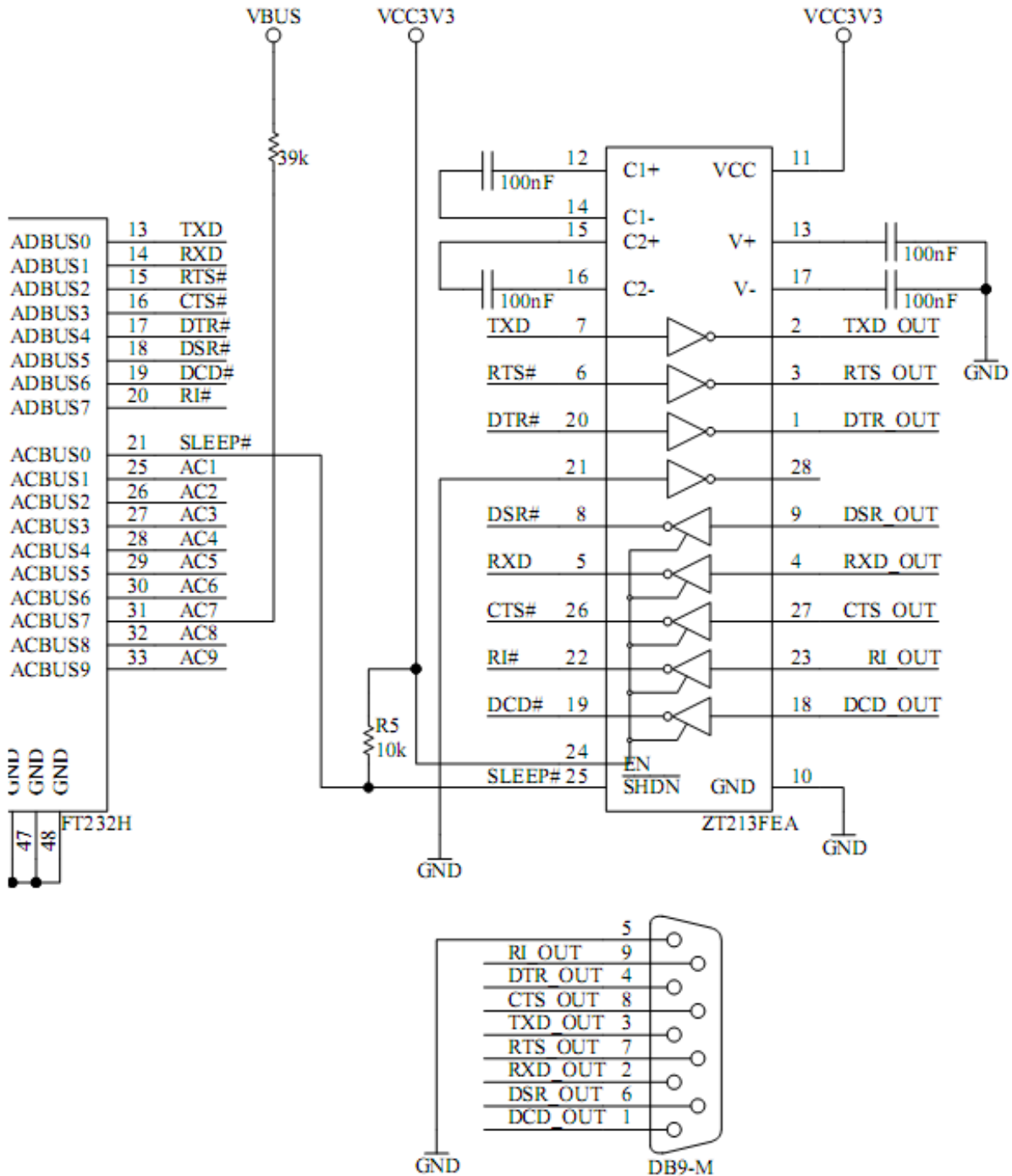

**Figure 4.1 RS232 Configuration**

### 4.3.2 RS422 Configuration

Figure 4.2 illustrates how the FT232H can be configured as a RS422 interface.

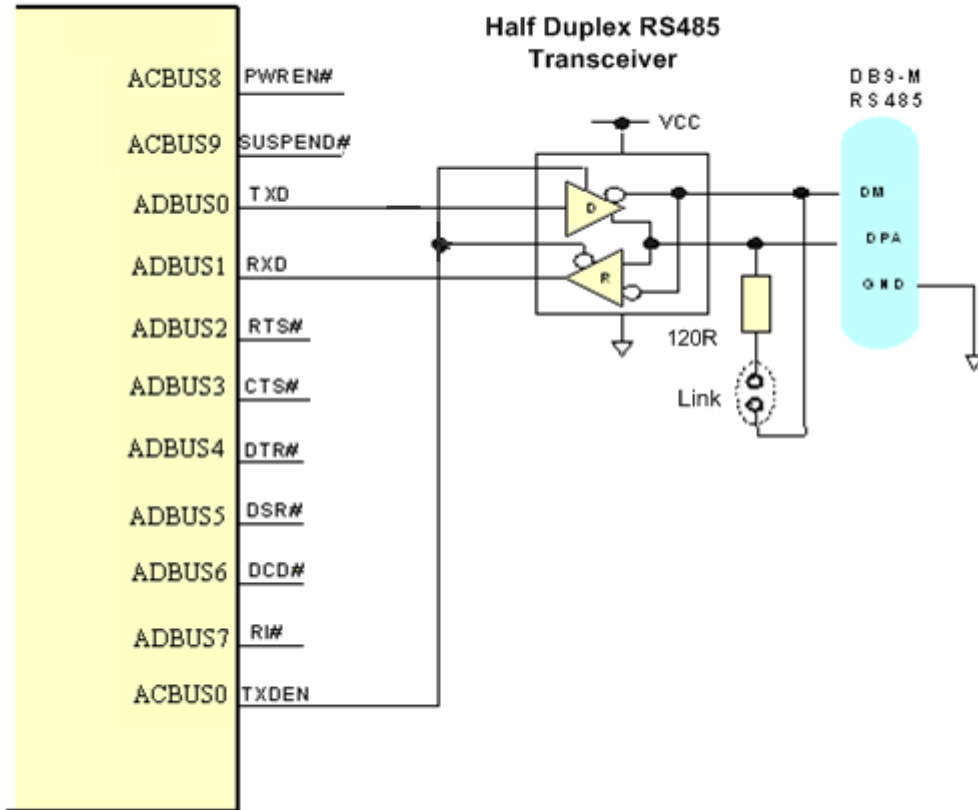

**Figure 4.2 Dual RS422 Configuration**

In this case the FT232H is configured as UART operating at TTL levels and a level converter device (full duplex RS485 transceiver) is used to convert the TTL level signals from the FT232H to RS422 levels. The PWREN# signal is used to power down the level shifters such that they operate in a low quiescent current when the USB interface is in suspend mode.

### 4.3.3 RS485 Configuration

Figure 4.3 illustrates how the FT232H can be configured as a RS485 interface.

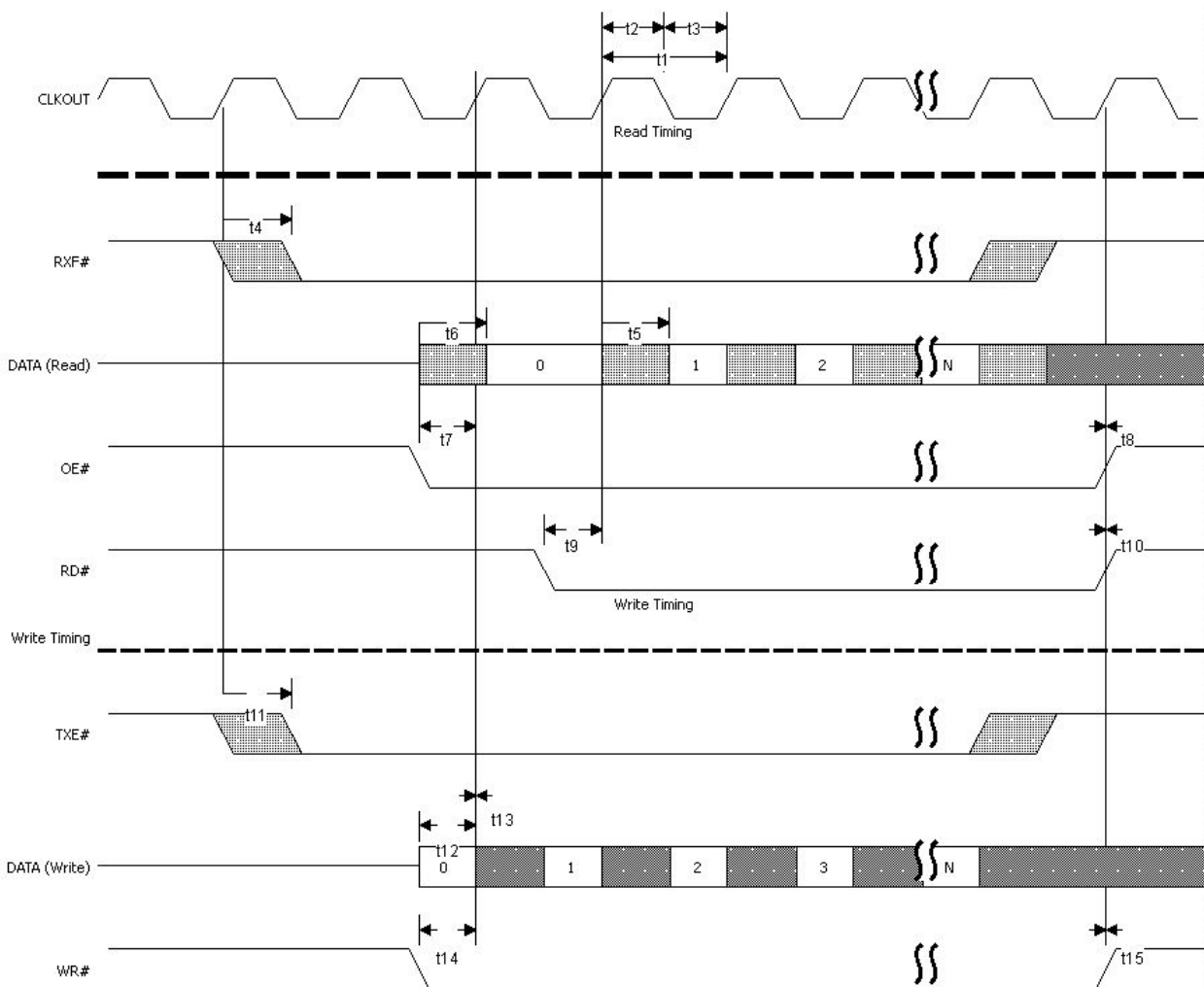

**Figure 4.3 Dual RS485 Configuration**

In this case the FT232H is configured as a UART operating at TTL levels and a level converter device (half duplex RS485 transceiver) is used to convert the TTL level signals from the FT232H to RS485 levels. With RS485, the transmitter is only enabled when a character is being transmitted from the UART. The TXDEN pin on the FT232H is provided for exactly that purpose, and so the transmitter enables are wired to the TXDEN. RS485 is a multi-drop network – i.e. many devices can communicate with each other over a single two wire cable connection. The RS485 cable requires to be terminated at each end of the cable. Links are provided to allow the cable to be terminated if the device is physically positioned at either end of the cable.

## 4.4 FT245 Synchronous FIFO Interface Mode Description

When FT232H is configured in an FT245 Synchronous FIFO interface mode the IO timing of the signals used are shown in Figure 4.4 which shows details for read and write accesses. The timings are shown in Figure 4.4. Note that only a read or a write cycle can be performed at any one time. Data is read or written on the rising edge of the CLKOUT clock.



**Figure 4.4 FT245 Synchronous FIFO Interface Signal Waveforms**

Name	Min	Nom	Max	Units	Comments
t1		16.67		ns	CLKOUT period
t2	7.5	8.33	9.17	ns	CLKOUT high period
t3	7.5	8.33	9.17	ns	CLKOUT low period
t4	0		9	ns	CLKOUT to RXF#
t5	0		9	ns	CLKOUT to read DATA valid
t6	0		9	ns	OE# to read DATA valid
t7	7.5		16.67	ns	OE# setup time
t8	0			ns	OE# hold time
t9	7.5		16.67	ns	RD# setup time to CLKOUT (RD# low after OE# low)
t10	0			ns	RD# hold time
t11	0		9	ns	CLKOUT TO TXE#
t12	7.5		16.67	ns	Write DATA setup time
t13	0			ns	Write DATA hold time
t14	7.5		16.67	ns	WR# setup time to CLKOUT (WR# low after TXE# low)
t15	0				WR# hold time

**Table 4.1 FT245 Synchronous FIFO Interface Signal Timings**

This mode uses a synchronous interface to get high data transfer speeds. The chip drives a 60 MHz CLKOUT clock for the external system to use.

Note that Asynchronous FIFO mode must be selected in the EEPROM before selecting the Synchronous FIFO mode in software.

#### **4.4.1 FT245 Synchronous FIFO Read Operation**

A read operation is started when the chip drives RXF# low. The external system can then drive OE# low to turn the data bus drivers around before acknowledging the data with the RD# signal going low. The first data byte is on the bus after OE# is low. The external system can burst the data out of the chip by keeping RD# low or it can insert wait states in the RD# signal. If there is more data to be read it will change on the clock following RD# sampled low. Once all the data has been consumed, the chip will drive RXF# high. Any data that appears on the data bus, after RXF# is high, is invalid and should be ignored.

#### **4.4.2 FT245 Synchronous FIFO Write Operation**

A write operation can be started when TXE# is low. WR# is brought low when the data is valid. A burst operation can be done on every clock providing TXE# is still low. The external system must monitor TXE# and its own WR# to check that data has been accepted. Both TXE# and WR# must be low for data to be accepted.



## 4.5 FT245 Style Asynchronous FIFO Interface Mode Description

The FT232H can be configured as an asynchronous FIFO interface. This mode is similar to the synchronous FIFO interface with the exception that the data is written to or read from the FIFO on the falling edge of the WR# or RD# signals.

This mode does not provide a CLKOUT signal and it does not expect an OE# input signal. The following diagrams illustrate the asynchronous FIFO mode timing.

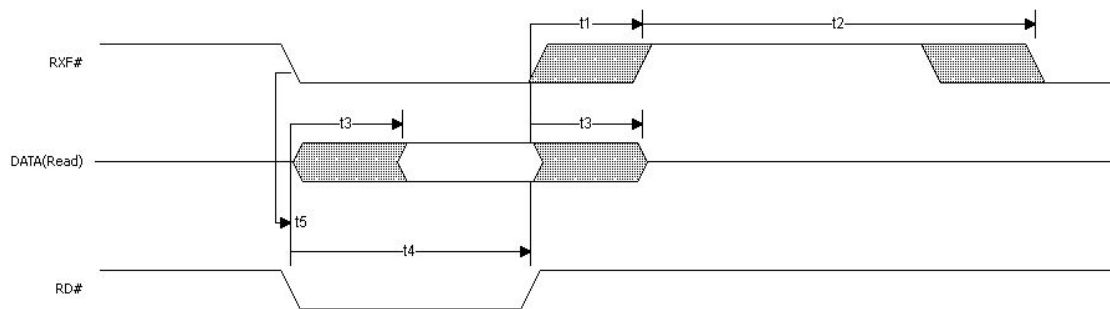

**Figure 4.5 FT245 Asynchronous FIFO Interface READ Signal Waveforms**

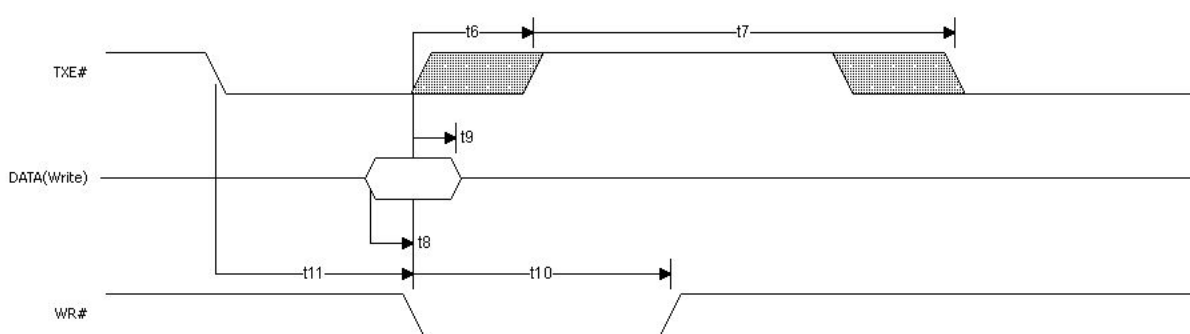

**Figure 4.6 FT245 Asynchronous FIFO Interface WRITE Signal Waveforms**

Time	Description	Min	Max	Units
T1	RD# inactive to RXF#	1	14	ns
T2	RXF# inactive after RD# cycle	49		ns
T3	RD# to DATA	1	14	ns
T4	RD# active pulse width	30		ns
T5	RD# active after RXF#	0		ns
T6	WR# active to TXE# inactive	1	14	ns
T7	TXE# active to TXE# after WR# cycle	49		ns
T8	DATA to WR# active setup time	5		ns
T9	DATA hold time after WR# inactive	5		ns
T10	WR# active pulse width	30		ns
T11	WR# active after TXE#	0		ns

**Table 4.2 Asynchronous FIFO Timings (based on standard drive level outputs)**

## 4.6 FT1248 Interface Mode Description

The FT232H supports a half-duplex FT1248 Interface that provides a flexible data communication and high performance interface between the FT232H as a FT1248 slave and an external FT1248 master. The FT1248 protocol is a dynamic bi-directional data bus interface that can be configured as 1, 2, 4, or 8-bits wide.



**Figure 4.7 FT1248 Bus with Single Master and Slave.**

In the FT1248 there are 3 distinct phases:

While SS<sub>n</sub> is inactive, the FT1248 reflects the status of the write buffer and read buffers on the MIOSIO[0] and MISO wires respectively. Additionally, the FT1248 slave block supports multiple slave devices where a master can communicate with multiple FT1248 slave devices. When the slave is sharing buses with other FT1248 slave devices, the write and read buffer status cannot be reflected on the MIOSIO[0] and MISO wires during SS<sub>n</sub> inactivity as this would cause bus contention. Therefore, it is possible for the user to select whether they wish to have the buffer status switched on or off during inactivity. When SS<sub>n</sub> is active a command/bus size phase occurs first. Following the command phase is the data phase, for each data byte transferred the FT1248 slave drives an ACK/NAK status onto the MISO wire. The master can send multiple data bytes so long as SS<sub>n</sub> is active, if a unsuccessful data transfer occurs, i.e. a NAK happens on the MISO wire then the master should immediately abort the transfer by de-asserting SS<sub>n</sub>.

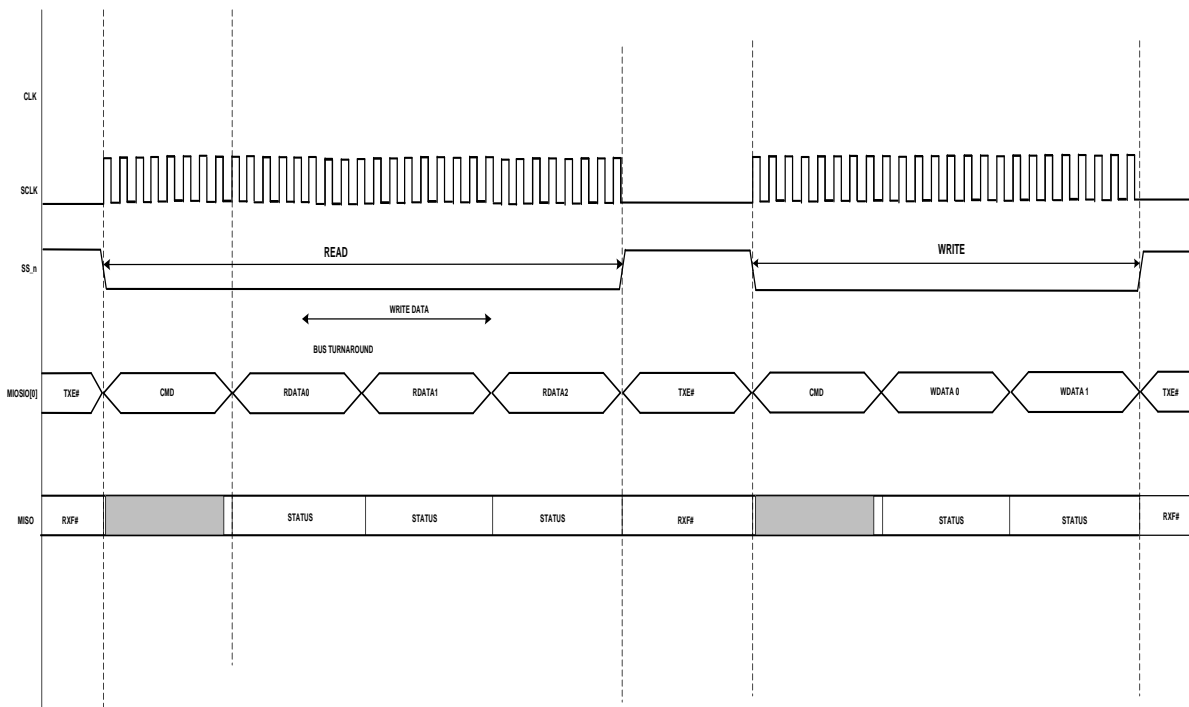

**Figure 4.8 FT1248 Basic Waveform Protocol**

Section 4.6.2 illustrates the FT1248 write and read protocol operating in 1-bit mode. For details regarding 2-bit, 4-bit and 8-bit modes, please refer to application note AN\_167\_FT1248 Parallel Serial Interface Basics available at <http://www.ftdichip.com>.

### 4.6.1 Bus Width Protocol Decode

In order for the FT1248 master to determine the bus width within the command phase the bus width is encoded along with the actual commands on the first active clock edge when SS<sub>n</sub> is active and has a data width of 8-bits.

If any of the MIOSIO [7:4] signals are low then the data transfer width equals 8-bits.

If any of the MIOSIO [3:2] signals are low then the data transfer width equals 4-bits.

If MIOSIO [1] signal is low then the data transfer width equals 2-bits.

Else the bus width is defaulted to 1-bit.

Please note that if both of the MIOSIO bit signals are low then the data transfer width is equal to the width of high priority MIOSIO bit signal. For example if both of the MIOSIO [7:3] signals are low then the data transfer width equals 8-bits or if both of the MIOSIO [3:1] signals are low then the data transfer width equals 4-bits.

In order to successfully decode the bus width, all MIOSIO signals must have pull up resistors. By default, all MIOSIO signals shall be seen by the FT232H in FT1248 mode as logic '1'. This means that when a FT1248 master does not wish to use certain MIOSIO signals the slave (FT232H) is still capable of determining the requested bus width since any unused MIOSIO signals shall be pull up in the slave.

The remaining bits used during the command phase are used to contain the command itself which means that it is possible to define up to 16 unique commands.

	LSB					MSB		
	CMD[3]	BWID 2-bit	BWID 4-bit	CMD[2]	BWID 8-bit	CMD[1]	CMD[0]	X
	0	1	2	3	4	5	6	7
1-bit Bus Width	CMD[3]	X	X	CMD[2]	X	CMD[1]	CMD[0]	X
	0	1	2	3	4	5	6	7
2-bit Bus Width	CMD[3]	0	X	CMD[2]	X	CMD[1]	CMD[0]	X
	0	1	2	3	4	5	6	7
4-bit Bus Width	CMD[3]	X	0	CMD[2]	X	CMD[1]	CMD[0]	X
	0	1	2	3	4	5	6	7
8-bit Bus Width	CMD[3]	X	X	CMD[2]	0	CMD[1]	CMD[0]	X
	0	1	2	3	4	5	6	7

**Figure 4.9 FT1248 Command Structure**

For more details about FT1248 Interface, please refer to application note AN\_167\_FT1248 Parallel Serial Interface Basics available at <http://www.ftdichip.com>.

### 4.6.2 FT1248: 1-bit interface

The FT1248 Interface transfers data over different bus widths (1-bit, 2-bit, 4-bit and 8-bit). Figure 4.21 and Figure 4.22 illustrate the waveform detailing the FT1248 write and read protocol operating in 1-bit mode with flow control. Please refer to the application notes AN\_167\_FT1248 Parallel Serial Interface Basics available at <http://www.ftdichip.com> for more details regarding 1-bit without flow control, 2-bit, 4-bit and 8-bit modes.

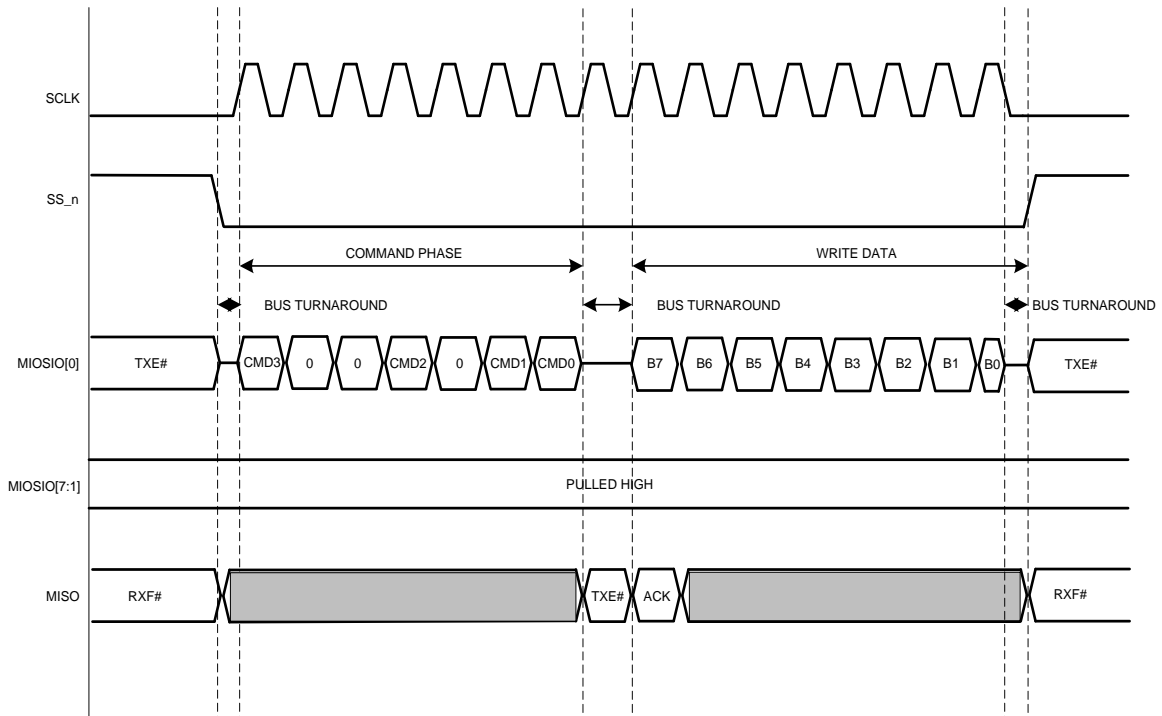

**Figure 4.10 FT1248 1-bit Mode Protocol (WRITE)**

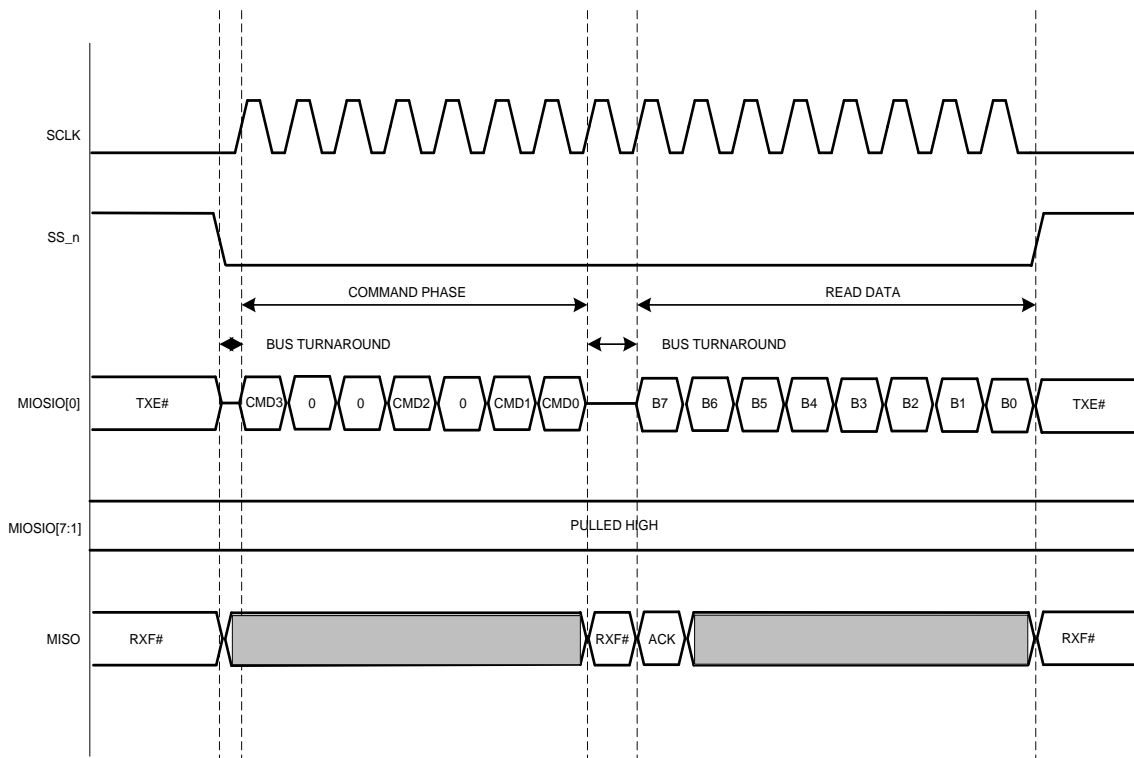

**Figure 4.11 FT1248 1-bit Mode Protocol (READ)**

When SS<sub>n</sub> is inactive the write buffer and read buffer status is reflected on the MIOSIO[0] and MISO signals respectively. When the master wishes to initiate a data transfer, SS<sub>n</sub> becomes active. As soon as SS<sub>n</sub> becomes active the SPI slave immediately stops driving the MIOSIO[0] signal and SPI master is not allowed to begin driving the MIOSIO[0] signal until the first clock edge, this ensures that bus contention is avoided.

On the first clock edge the command is shifted out for 7 clocks, on the 8<sup>th</sup> clock cycle a bus turnaround is required. The bus turnaround is required as the slave may be required to drive the MIOSIO[0] bus with read data. The data phase occurs in response to the command and so long as SS<sub>n</sub> remains active. The data phase in 1-bit mode requires 8 clock cycles where the MIOSIO[0] signal transfers the requested write or read data. The MISO signal indicates to the master the success of the transfer with an ACK or NAK.

The status is reflected through the whole of the data phase and is valid from the first clock edge. If the master is writing data to the slave, then on the last clock edge before it de-asserts SS<sub>n</sub> must tristate the MIOSIO[0] signal to enable the bus to be “turned” around as when SS<sub>n</sub> becomes inactive the FT1248 slave shall begin to drive the write buffer status onto the MIOSIO[0] signal. When the SPI slave is driving the MIOSIO[0] (the master is reading data) no bus turnaround is required as when SS<sub>n</sub> becomes inactive it is required to drive the write buffer status to the FT1248 master.

## 4.7 Synchronous and Asynchronous Bit-Bang Interface Mode

The FT232H can be configured as a bit-bang interface. There are two types of bit-bang modes: synchronous and asynchronous.

See application note [AN2232-02 Bit Mode Functions for the FT232](#) for more details and examples of using both Synchronous and Asynchronous bit-bang modes.

### 4.7.1 Asynchronous Bit-Bang Mode

Asynchronous Bit-Bang mode is the same as BM-style Bit-Bang mode, except that the internal RD# and WR# strobes (RDSTB# and WRSTB#) are now brought out of the device to allow external logic to be clocked by accesses to the bit-bang IO bus.

Any data written to the device in the normal manner will be self-clocked onto the data pins (those which have been configured as outputs). Each pin can be independently set as an input or an output. The rate that the data is clocked out at is controlled by the baud rate generator.

New data must be written, and the baud rate clock should tick to change the data. If no new data is written to the chip, the pins configured for output will hold the last value written.

Asynchronous Bit-Bang mode is enabled using the FT\_SetBitMode D2xx driver command with a hex value of 0x01.

### 4.7.2 Synchronous Bit-Bang Mode

The synchronous Bit-Bang mode will only update the output parallel port pins whenever data is sent from the USB interface to the parallel interface. When this is done, the WRSTB# will activate to indicate that the data has been read from the USB Rx FIFO buffer and written out on the pins. Data can only be received from the parallel pins (to the USB Tx FIFO interface) after the parallel interface has been written to.

With Synchronous Bit-Bang mode data will only be sent out by the FT232H if there is space in the FT232H USB TXFIFO for data to be read from the parallel interface pins. This Synchronous Bit-Bang mode will read the data bus parallel I/O pins first, before it transmits data from the USB Rx FIFO. It is therefore 1 byte behind the output, and so to read the inputs for the byte that you have just sent, another byte must be sent.

For example:

Figure 1. Pins start at 0xFF  
Send 0x55, 0xAA

Pins go to 0x55 and then to 0xAA  
Data read = 0xFF,0x55

(2) Pins start at 0xFF  
Send 0x55, 0xAA, 0xAA  
(repeat the last byte sent)  
Pins go to 0x55 and then to 0xAA  
Data read = 0xFF, 0x55, 0xAA

Synchronous Bit-Bang Mode differs from Asynchronous Bit-Bang mode in that the device parallel output is only read when the parallel output is written to by the USB interface. This makes it easier for the controlling program to measure the response to a USB output stimulus as the data returned to the USB interface is synchronous to the output data.

Synchronous Bit-Bang mode is enabled using Set Bit Bang Mode driver command with a hex value of 0x04.

An example of the synchronous bit-bang mode timing is shown in Figure 4.12

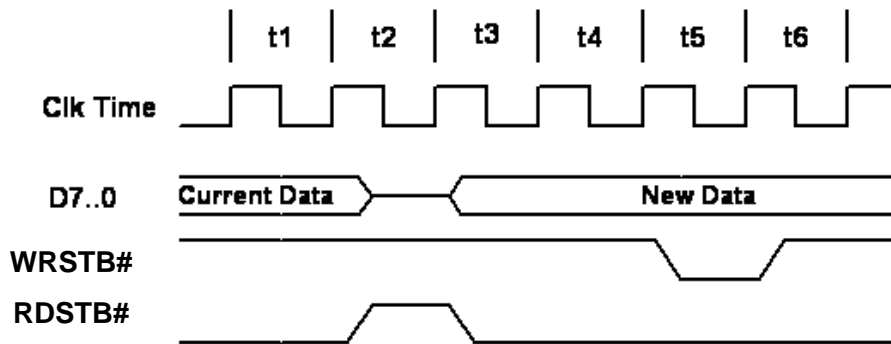

**Figure 4.12 Synchronous Bit-Bang Mode Timing Interface Example**

WRSTB# = this output indicates when new data has been written to the I/O pins from the Host PC (via the USB interface).

Name	Description
t1	Current pin state is read
t2	RDSTB# is set inactive and data on the parallel I/O pins is read and sent to the USB host.
T3	RDSTB# is set active again, and any pins that are output will change to their new data
t4	1 clock cycle to allow for data setup
t5	WRSTB# goes active. This indicates that the host PC has written new data to the I/O parallel data pins
t6	WRSTB# goes inactive

**Table 4.3 Synchronous Bit-Bang Mode Timing Interface Example Timings**

RDSTB# = this output rising edge indicates when data has been read from the I/O pins and sent to the Host PC (via the USB interface).

The WRSTB# goes active in t5. The WRSTB# goes active when data is read from the USB RXFIFO (i.e. sent from the PC). The RDSTB# goes inactive when data is sampled from the pins and written to the USB TXFIFO (i.e. sent to the PC). The SETUP command to the FT232H is used to setup the bit-mode. This command also contains a byte wide data mask to set the direction of each bit. The direction on each pin doesn't change unless a new SETUP command is used to modify the direction.

The WRSTB# and RDSTB# strobes are only a guide to what may be happening depending on the direction of the bus. For example if all pins are configured as inputs, it is still necessary to write to these pins in order to get the FT232H to read those pins even though the data written will never appear on the pins.

Signals and data-flow are illustrated in Figure 4.13



**Figure 4.13- Bit-bang Mode Dataflow Illustration Diagram**

## 4.8 MPSSE Interface Mode Description

MPSSE Mode is designed to allow the FT232H to interface efficiently with synchronous serial protocols such as JTAG, I<sup>2</sup>C and SPI (MASTER) Bus. It can also be used to program SRAM based FPGA's over USB. The MPSSE interface is designed to be flexible so that it can be configured to allow any synchronous serial protocol (industry standard or proprietary) to be implemented using the FT232H.

MPSSE is fully configurable, and is programmed by sending commands down the data stream. These can be sent individually or more efficiently in packets. MPSSE is capable of a maximum sustained data rate of 30 Mbits/s.

When the FT232H is configured in MPSSE mode, the IO timing and signals used are shown in Figure 4.14 and Table 4.4. These show timings for CLKOUT=30MHz. CLKOUT can be divided internally to provide a slower clock.



**Figure 4.14 MPSSE Signal Waveforms**

Name	Min	Typ	Max	Units	Comments
t1	32.66	33.33	33.99	ns	CLKOUT period
t2	15	16.67	18.33	ns	CLKOUT high period
t3	15	16.67	18.33	ns	CLKOUT low period
t4	0		7.50	ns	CLKOUT to TDI/DO delay
t5	0			ns	TDI/DO hold time
t6	11			ns	TDI/DO setup time

**Table 4.4 MPSSE Signal Timings**

MPSSE mode is enabled using the FT\_SetBitMode D2xx driver command with a hex value of 0x02. A hex value of 0x00 will reset the device. See application note [AN135 – MPSSE Basics](#) for more details and examples.

The MPSSE command set is fully described in application note [AN108 – Command Processor For MPSSE and MCU Host Bus Emulation Modes](#).

### 4.8.1 MPSSE Adaptive Clocking

The Adaptive Clock mode correlates the CLK signal with a return clock RTCK. This is a technique used by ARM® processors.

The FT232H will assert the TCK line and wait for the RTCK to be returned from the target device to GPIOL3 line before changing the TDO (data out line).

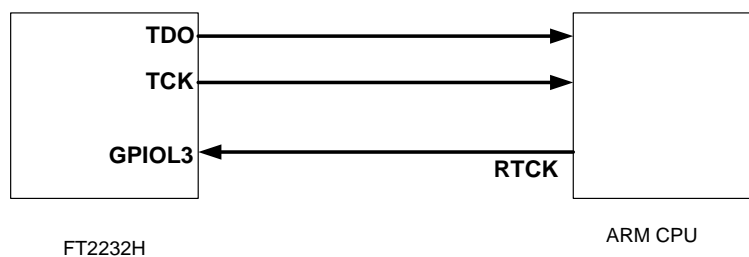

**Figure 4.15 Adaptive Clocking Interconnect**

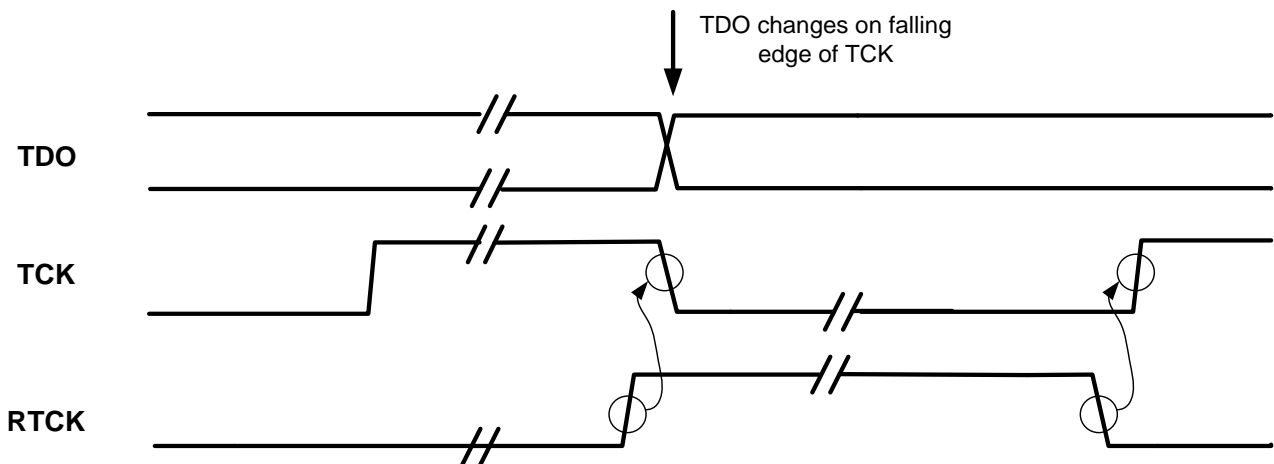

**Figure 4.16 Adaptive Clocking Waveform**

Adaptive clocking is not enabled by default.

For further details on MPSSE adaptive clocking please refer to AN\_108 [Command Processor For MPSSE and MCU Host Bus Emulation Modes](#).



## 4.9 Fast Serial Interface Mode Description

Fast Serial Interface Mode provides a method of communicating with an external device over USB using 4 wires that can have opto-isolators in their path, thus providing galvanic isolation between systems. Fast serial mode is enabled by setting the appropriate bits in the external EEPROM. The fast serial mode can be held in reset by setting a bit value of 0x10 using the FT\_SetBitMode D2XX driver command. While this bit is set the device is held reset – data can be sent to the device, but it will not be sent out by the device until the device is enabled again. This is done by sending a bit value of 0x00 using the Set Bit Mode command.

When the FT232H is configured in Fast Serial Interface mode the IO timing of the signals used are shown in Figure 4.17 and the timings are shown in Table 4.5 Fast Serial Interface Signal Timings.

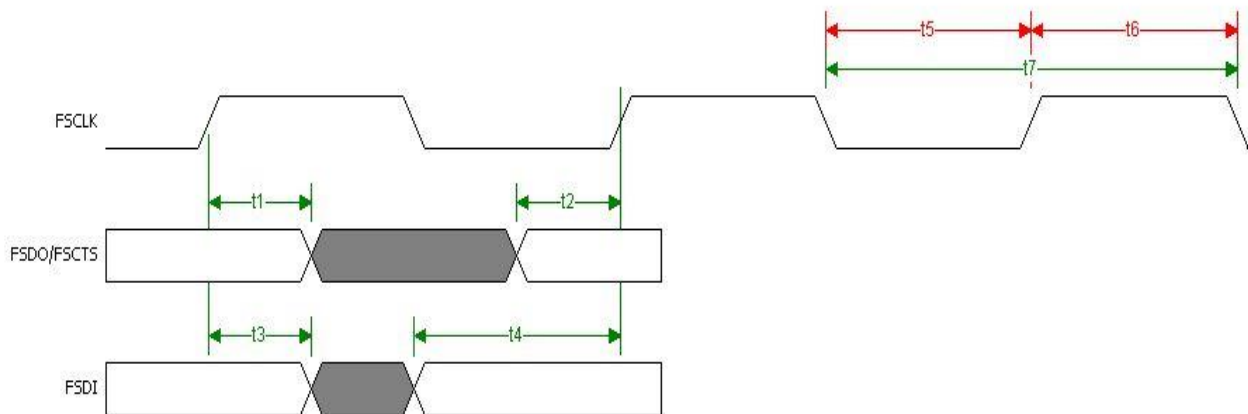

**Figure 4.17 Fast Serial Interface Signal Waveforms**

Name	Minimum	Typical	Maximu	Units	Description
t1	5			ns	FSDO/FSCCTS hold time
t2	5			ns	FSDO/FSCCTS setup time
t3	5			ns	FSDI hold time
t4	10			ns	FSDI Setup Time
t5	10			ns	FSCLK low
t6	10			ns	FSCLK high
t7	20			ns	FSCLK Period

**Table 4.5 Fast Serial Interface Signal Timings**

### 4.9.1 Outgoing Fast Serial Data

To send fast serial data out of the FT232H, the external device must drive the FSCLK clock. If the FT232H has data ready to send, it will drive FSDO output low to indicate the start bit. It will not do this if it is currently receiving data from the external device. This is illustrated in Figure 4.18.

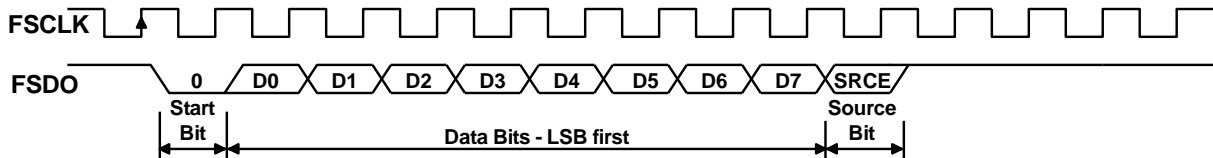

**Figure 4.18 Fast Serial Interface Output Data**

**Notes:**

1. The first bit output (Start bit) is always 0.
2. FSDO is always sent LSB first.
3. The last serial bit output is the source bit (SRCE) is always 0.
4. If the target device is unable to accept the data when it detects the START bit, it should stop the FSCLK until it can accept the data.

### 4.9.2 Incoming Fast Serial Data

An external device is allowed to send data into the FT232H if FSCTS is high. On receipt of a zero START bit on FSDI, the FT232H will drop FSCTS on the next positive clock edge. The data from bits 0 to 7 are then clocked in (LSB first). The last bit (DEST) determines where the data will be written to. This bit is always 0 with the FT232H. This is illustrated in Figure 4.19.



**Figure 4.19 Fast Serial Interface Input Data**

**Notes:**

1. The first bit input (Start bit) is always 0.
2. FSDI is always received LSB first.
3. The last received serial bit is the destination bit (DEST) is always 0.
4. The target device should ensure that FSCTS is high before it sends data. FSCTS goes low after data bit 0 (D0) and stays low until the chip can accept more data.

### 4.9.3 Fast Serial Data Interface Example

Figure 4.20 shows example of two Agilent HCPL-2430 (see the semiconductor section at [www.avagotech.com](http://www.avagotech.com)) Hi-Speed opto-couplers used to optically isolate an external device which interfaced to USB using the FT232H. In this example VCC5V is the USB VBUS supply and VCCE is the supply to the external device.

Care must be taken with the voltage used to power the photo-LED. It must be the same voltage as that which the FT232H I/Os are driving to, or the LED's may be permanently on. Limiting resistors should be fitted in the lines that drive the diodes. The outputs of the opto-couplers are open-collector and require a pull-up resistor.



**Figure 4.20 Fast Serial Interface Example**

### 4.10 CPU-style FIFO Interface Mode Description

CPU-style FIFO interface mode is designed to allow a CPU to interface to USB via the FT232H. This mode is enabled in the external EEPROM. The interface is achieved using a chip select bit (CS#) and address bit (A0). When the FT232H is in CPU-style Interface mode, the IO signal lines are configured as given in Table 4.6. This mode uses a combination of CS# and A0 to determine the operation to be carried out. The following Truth-Table 4.7 gives the decode values for particular operations.

CS#	A0	RD#	WR#
1	X	X	X
0	0	Read Data Pipe	Write Data Pipe
0	1	Read Status	Send Immediate

**Table 4.6 CPU-Style FIFO Interface Operation Select**

The Status read is shown in Table 4.7 –

Data Bit	Data	Status
bit 0	1	Data available (=RXF)
bit 1	1	Space available (=TXE)
bit 2	1	Suspend
bit 3	1	Configured
bit 4	X	X
bit 5	X	X
bit 6	X	X
bit 7	X	X

**Table 4.7 CPU-Style FIFO Interface Operation Read Status Description**

Note that bits 7 to 4 can be arbitrary values and that X= not used.

The timing of reading and writing in this mode is shown in Figure 4.21 and Table 4.8.

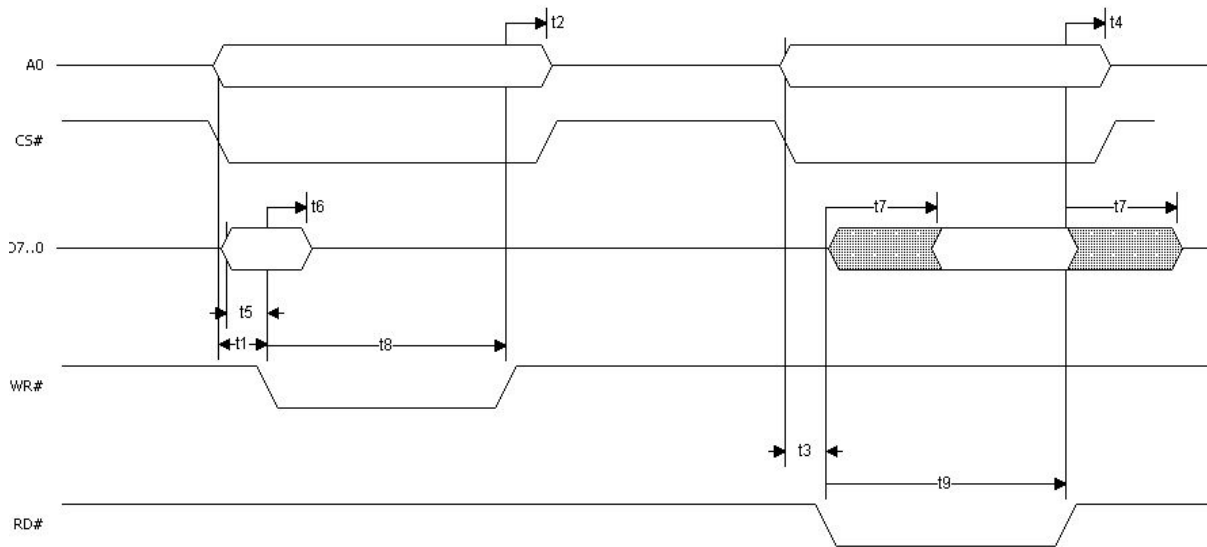
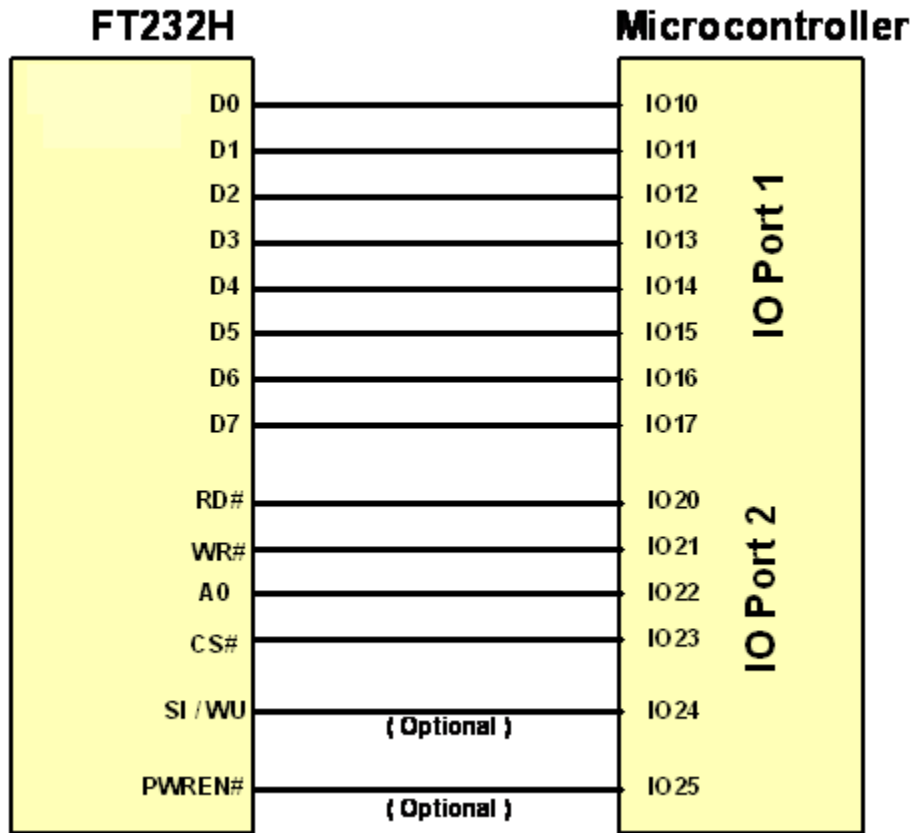

**Figure 4.21 CPU-Style FIFO Interface Operation Signal Waveforms**

Data Bit	Nom	Max	Units	Comment
t1	5		ns	A0/CS# setup time to WR#
t2	5		ns	A0/CS# hold time after WR# inactive
t3	5		ns	A0/CS# setup time to RD#
t4	5		ns	A0/CS# hold time after RD# inactive
t5	5		ns	D to WR# 36active setup time
t6	5		ns	D hold time after WR# inactive
t7	1	14	ns	RD# to D
t8	30		ns	WR# active pulse width
t9	30		ns	RD# active pulse width

**Table 4.8 CPU-Style FIFO Interface Operation Signal Timing**

An example of the CPU-style FIFO interface connection is shown in Figure 4.22



**Figure 4.22 CPU-Style FIFO Interface Example**

### 4.11 RS232 UART Mode LDE Interface Description

When configured in UART mode the FT232H has two IO pins dedicated to controlling LED status indicators, one for transmitted data the other for received data. When data is being transmitted or received the respective pins drive from tristate to low in order to provide indication on the LED's of data transfer. A digital one-shot timer is used so that even a small percentage of data transfer is visible to the end user.

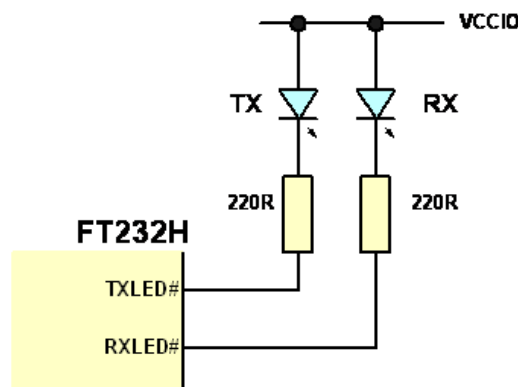

**Figure 4.23 Dual LED UART Configuration**

Figure 4.23 shows a configuration using two individual LED's – one for transmitted data the other for received data.



**Figure 4.24 Single LED UART Configuration**

In Figure 4.24 transmit and receive LED indicators are wire-OR'ed together to give a single LED indicator which indicates any transmit or receive data activity.

Note that the LED's are connected to the same supply as VCCIO.

## 4.12 Send Immediate/Wake Up (SIWU#)

The SIWU# pin is available in the FIFO modes and in bit bang mode.

The Send Immediate portion is used to flush data from the chip back to the PC. This can be used to force short packets of data back to the PC without waiting for the latency timer to expire.

To avoid overrunning, this mechanism should only be used when a process of sending data to the chip has been stopped.

The data transfer is flagged to the USB host by the falling edge of the SIWU# signal. The USB host will schedule the data transfer on the next USB packet.



**Figure 4.25 Using SIWU#**

When the pin is being used for a Wake Up function to wake up a sleeping PC a 20ms negative pulse on this pin is required. When the pin is used to immediately flush the buffer (Send Immediate) a 250ns negative pulse on this pin is required.

**Notes:**

1. When using remote wake-up, ensure the resistors are pulled-up in suspend. Also ensure peripheral designs do not allow any current sink paths that may partially power the peripheral.
2. If remote wake-up is enabled, a peripheral is allowed to draw up to 2.5mA in suspend. If remote wake-up is disabled, the peripheral must draw no more than 500uA in suspend.
3. If a Pull-down is enabled, the FT232H will not wake up from suspend when using SIWU#
4. In UART mode the RI# pin acts as the wake up pin.

### 4.13 FT232H Mode Selection

The FT232H defaults to asynchronous serial interface (UART) mode of operation.

After a reset the required mode is determined by the contents of the external EEPROM which can be programmed using [FT\\_Prog](#).

The EEPROM contents determine if the FT232H device is configured as FT232 asynchronous serial interface, FT245 FIFO interface, CPU-style FIFO interface, FT1248 or Fast Serial Interface.

Following a reset, the EEPROM is read and the FT232H configured for the selected mode. After device enumeration, the **FT\_SetBitMode** command (refer to [D2XX Programmers Guide](#)) can be sent to the USB driver to switch the selected interface into other modes – asynchronous bit-bang, synchronous bit-bang or MPSSE – if required.

When in FT245 FIFO mode, the **FT\_SetBitMode** command can be used to select Synchronous FIFO (**FT\_SetBitMode** = 0x40). Note that FT245 FIFO mode must be configured in the EEPROM before selecting the Synchronous FIFO mode.

The drive strength selection, slew rate and Schmitt input function can also be configured in the EEPROM.

The MPSSE can be configured directly using the D2XX commands. The [D2XX Programmers Guide](#) is available from the [FTDI website](#). The application note [AN\\_108 – Command Processor for MPSSE and MCU Host Bus Emulation Modes](#) gives further explanation and examples for the MPSSE.

### 4.14 Modes Configuration

This section summarises what modes are configurable using the external EEPROM or the application software.

	ASYNC Serial UART	STYLE ASYNC 245 FIFO	SYNC 245 PARALLEL FIFO	FT1248	ASYNC Bit-Bang	SYNC Bit-Bang	MPSSE	Fast Serial Interface	CPU-Style FIFO
<b>EEPROM configured</b>	YES	YES	YES	YES	NO	NO	NO	YES	YES
<b>Application Software configured</b>	NO	NO	YES	NO	YES	YES	YES	RESET	NO

**Table 4.9 Configuration Using EEPROM and Application Software**

**Note:**

1. The Synchronous 245 FIFO mode requires both the EEPROM and application software mode settings
2. The application software can be used to reset the fast serial interface controller

## 5 Devices Characteristics and Ratings

### 5.1 Absolute Maximum Ratings

The absolute maximum ratings for the FT232H devices are as follows. These are in accordance with the Absolute Maximum Rating System (IEC 60134). Exceeding these values may cause permanent damage to the device.

Parameter	Value	Unit	Conditions
Storage Temperature	-65°C to 150°C	Degrees C	
Floor Life (Out of Bag) At Factory Ambient (30°C / 60% Relative Humidity)	168 Hours (IPC/JEDEC J-STD-033A MSL Level 3 Compliant)*	Hours	
Ambient Operating Temperature (Power Applied)	-40°C to 85°C	Degrees C	
MTTF FT232HL	TBD	Hours	
MTTF FT232HL	TBD	Hours	
VCORE Supply Voltage	-0.3 to +2.0	V	
VCCIO IO Voltage	-0.3 to +4.0	V	
DC Input Voltage – USBDP and USBDM	-0.5 to +3.63	V	
DC Input Voltage – High Impedance Bi-directional (ACBUS and ADBUS powered from VCCIO)	-0.3 to +5.8	V	
DC Output Current – Outputs	16	mA	

**Table 5.1 Absolute Maximum Ratings**

\* If devices are stored out of the packaging beyond this time limit the devices should be baked before use. The devices should be ramped up to a temperature of +125°C and baked for up to 17 hours.

### 5.2 DC Characteristics

The I/O pins are +3.3v cells, which are +5V tolerant (except the USB PHY pins).

DC Characteristics (Ambient Temperature = -40°C to +85°C)

Parameter	Description	Minimum	Typical	Maximum	Units	Conditions
VCORE	VCC Core Operating Supply Voltage	1.62	1.8	1.98	V	
VCCIO*	VCCIO Operating Supply Voltage	2.97		3.63	V	Cells are 5V tolerant
VREGIN 5 Volts	VREGIN Voltage regulator Input	3.6	5	5.5	V	5 volt input to VREGIN
VREGIN 3.3 Volts	VREGIN Voltage regulator Input	3.3	3.3	3.6	V	3.3 volt input to VREGIN
Ireg	Regulator Current		54		mA	VREGIN +5V
Ireg	Regulator Current		52		mA	VREGIN +3.3V
Icc1	Core Operating Supply Current		24		mA	VCORE = +1.8V Normal Operation
Icc1r	Core Reset Supply Current		4.3		mA	VCORE = +1.8V Device in reset state
Icc1s	Core Suspend Supply Current		330		µA	VCORE = +1.8V USB Suspend

**Table 5.2 Operating Voltage and Current (except PHY)**

**Note:** Failure to connect all VCCIO pins of the device will have unpredictable behaviour.



The I/O pins are +3.3v cells, which are +5V tolerant (except the USB PHY pins).

Parameter	Description	Minimum	Typical	Maximum	Units	Conditions
Voh	Output Voltage High	2.4	VCCIO	VCCIO	V	Ioh = +/-2mA I/O Drive strength* = 4mA
		2.4	VCCIO	VCCIO	V	I/O Drive strength* = 8mA
		2.4	VCCIO	VCCIO	V	I/O Drive strength* = 12mA
		2.4	VCCIO	VCCIO	V	I/O Drive strength* = 16mA
Vol	Output Voltage Low		0	0.4	V	Iol = +/-2mA I/O Drive strength* = 4mA
			0	0.4	V	I/O Drive strength* = 8mA
			0	0.4	V	I/O Drive strength* = 12mA
			0	0.4	V	I/O Drive strength* = 16mA
Vil	Input low Switching Threshold			0.8	V	LVTTL
Vih	Input High Switching Threshold	2.0			V	LVTTL
Vt	Switching Threshold		1.5		V	LVTTL
Vt-	Schmitt trigger negative going threshold voltage	0.8	1.1		V	
Vt+	Schmitt trigger positive going threshold voltage		1.6	2.0	V	
Rpu	Input pull-up resistance	40	75	190	KΩ	Vin = 0
Rpd	Input pull-down resistance	40	75	190	KΩ	Vin = VCCIO
Iin	Input Leakage Current	-10	+/-1	10	μA	Vin = 0
Ioz	Tristate output leakage current	-10	+/-1	10	μA	Vin = 5.5V or 0

**Table 5.3 I/O Pin Characteristics VCCIO = +3.3V (except USB PHY pins)**

\* The I/O drive strength and slow slew-rate are configurable in the EEPROM.

DC Characteristics (Ambient Temperature = -40°C to +85°C)

Parameter	Description	Minimum	Typical	Maximum	Units	Conditions
VPHY, VPLL	PHY Operating Supply Voltage	3.0	3.3	3.6	V	3.3V I/O
Iccphy	PHY Operating Supply Current	---	30	60	mA	Hi-speed operation at 480 MHz
Iccphy (susp)	PHY Operating Supply Current	---	10	50	μA	USB Suspend

**Table 5.4 PHY Operating Voltage and Current**

Parameter	Description	Minimum	Typical	Maximum	Units	Conditions
Voh	Output Voltage High	VCORE-0.2			V	
Vol	Output Voltage Low			0.2	V	
Vil	Input low Switching Threshold			0.8	V	
Vih	Input High Switching Threshold	2.0			V	

**Table 5.5 PHY I/O Pin Characteristics**

### 5.3 ESD Tolerance

ESD protection for FT232H IO's

Parameter	Reference	Minimum	Typical	Maximum	Units
Human Body Model (HBM)	JEDEC EIA/JESD22-A114-B, Class 2		±2kV		kV
Machine Mode (MM)	JEDEC EIA/JESD22-A115-A, Class B		±200V		V
Charge Device Model (CDM)	JEDEC EIA/ JESD22-C101-D, Class-III		±500V		V
Latch-up	JESD78, Trigger Class-II		±200mA		mA

**Table 5.6 ESD Tolerance**



## 6.2 USB Self Powered Configuration

### 6.2.1 Self-Powered Application Example 1

Self-powered configuration running on 5V.

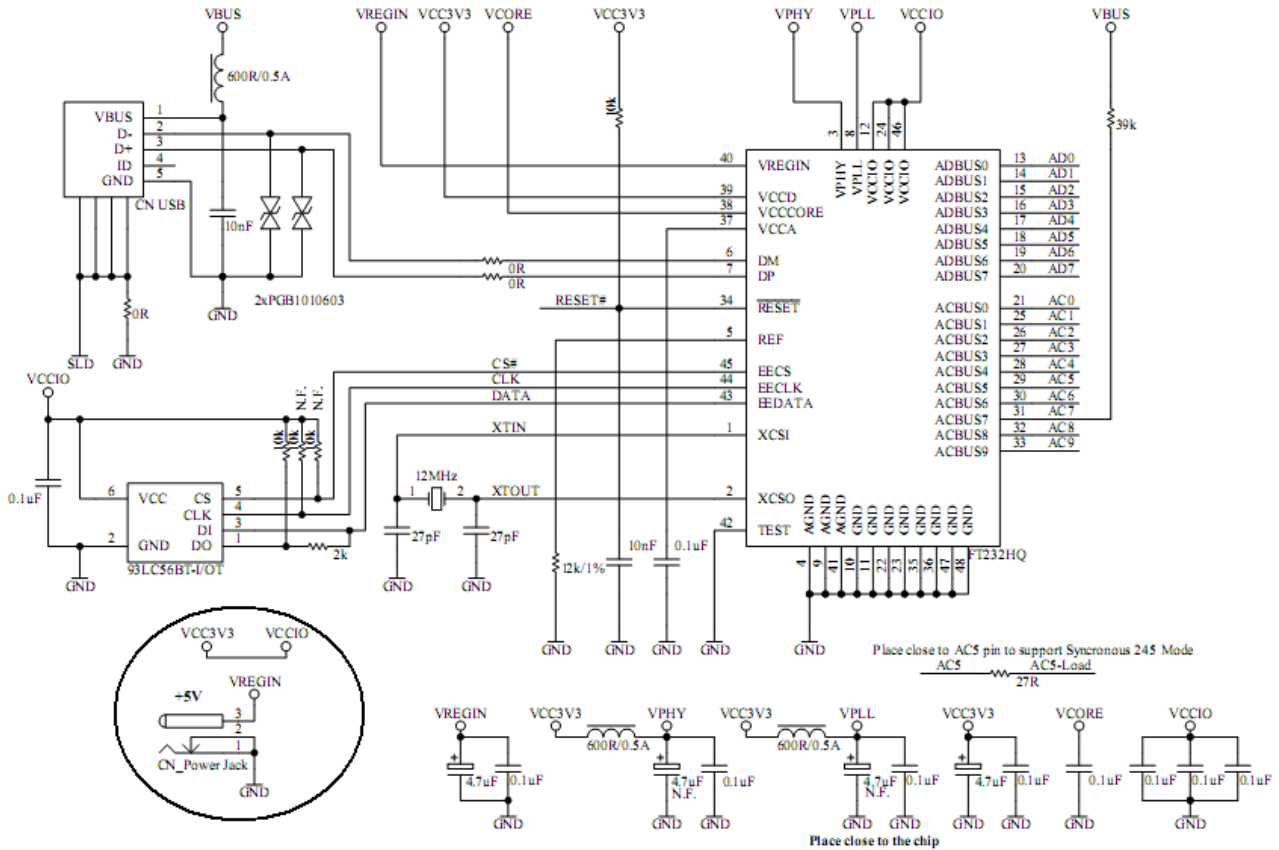

**Figure 6.2 Self-Powered Configuration Example 1**

Figure 6.2 illustrates the FT232H in a typical USB self-powered configuration. A USB self-powered device gets its power from its own external power supply which is connected to VREGIN. In this application the VREGIN is the +5V input to the on chip +3.3V/1.8V regulator. The output of the on chip LDO regulator (+1.8V) drives pin 38, VCCORE and pin 37, VCCA. The output of the on chip LDO regulator (3.3V) supplies

3.3V to the VCCIOs, VPLL and VPHY through VCCD.

Please note that when the FT232H running on +5V (VREGIN), the VCCD becomes an output.

Note that in this set-up, the EEPROM should be configured for self-powered operation and the option "suspend on ACBUS7 low" is enabled in [FT\\_Prog](#). This configuration uses the ACBUS7 pin, when this function is enabled ACBUS7 should not be used as a GPIO in MPSSE mode.



### 6.3 Oscillator Configuration



**Figure 6.4 Recommended FT232H Oscillator Configuration**

Figure 6.4 illustrates how to connect the FT232H with a 12MHz  $\pm 0.003\%$  crystal. In this case loading capacitors should to be added between OSCI, OSCO and GND as shown. A value of 27pF is shown as the capacitor in the example – this will be good for many crystals but it is recommended to select the loading capacitor value based on the manufacturer’s recommendations wherever possible. It is recommended to use a fundamental mode, parallel cut type crystal.

It is also possible to use a 12 MHz Oscillator with the FT232H. In this case the output of the oscillator would drive OSCI, and OSCO should be left unconnected. The oscillator must have a CMOS output drive capability.

Parameter	Description	Minimum	Typical	Maximum	Units	Conditions
OSCI Vin	Input Voltage	2.97	3.3V	3.63	V	
Fin	Input Frequency		12MHz		MHz	$\pm 30\text{ppm}$
Ji	Cycle to cycle jitter		<150		pS	

**Table 6.1 OSCI Input characteristics**

## 7 EEPROM Configuration

### 7.1 EEPROM Interface

The FT232H uses configuration data from an external EEPROM. The EEPROM must be 16 bits wide (93LC56B) and powered from the same net as the core supply of +2.97 to +3.63 volts. Adding an external (93LC56B) EEPROM allows the chip to be configured as a serial UART (RS232 mode), parallel FIFO (245) mode, FT1248, fast serial (opto isolation) or CPU-Style FIFO.



**Figure 7.1 EEPROM Interface**

The external EEPROM can also be used to customise the USB VID, PID, Serial Number, Product Description Strings and Power Descriptor value of the FT232H for OEM applications. Other parameters controlled by the EEPROM include Remote Wake Up, Soft Pull Down on Power-Off and I/O pin drive strength.

If the FT232H is used without an external EEPROM the chip defaults to a USB to asynchronous serial UART (RS232 mode) port device. If no EEPROM is connected (or the EEPROM is blank), the FT232H uses its built-in default VID (0403), PID (6014) Product Description and Power Descriptor Value. In this case, the device will not have a serial number as part of the USB descriptor.

### 7.2 Default EEPROM Configuration

The external EEPROM (if it's fitted) can be programmed over USB using [FT\\_Prog](#). This allows a blank part to be soldered onto the PCB and programmed as part of the manufacturing and test process. Users who do not have their own USB Vendor ID but who would like to use a unique Product ID in their design can apply to FTDI for a free block of unique PIDs.

Contact FTDI support for this service.

Parameter	Value	Notes
USB Vendor ID (VID)	0403h	FTDI default VID (hex)
USB Product UD (PID)	6014h	FTDI default PID (hex)
bcd Device	009h	
Serial Number Enabled?	Yes	
Serial Number	See Note	None
Pull down I/O Pins in USB Suspend	Disabled	Enabling this option will make the device pull down on the UART interface lines when in USB suspend mode (PWREN# is high).
Manufacturer Name	FTDI	
Product Description	Single RS232-HS	
Max Bus Power Current	500mA	

Parameter	Value	Notes
Power Source	Bus Powered	
Device Type	FT232H	
USB Version	0200	Returns USB 2.0 device description to the host.
Remote Wake Up	Disabled	Taking RI# low will wake up the USB host controller from suspend in approximately 20 Ms. If enabled.
Hardware Interface	UART	Allows the user to select the hardware mode of the device. Options include: RS232 UART, 245 FIFO, CPU 245, OPTO Isolate and FT1248.
FT1248 Settings	00h	FT1248 can be configured to set: Clock Polarity High; Bit Order LSB and Flow Control Not Selected.
Suspend ACBus7 Low	Disabled	Enters low power state on ACBus7.
High Current I/Os	Disabled	Enables the high drive level on the UART and ACBUS I/O pins.
Load VCP Driver	Enabled	Makes the device load the VCP driver interface for the device.
ACBUS0	TriSt-PU	Default configuration of ACBUS0 – Input pulled up
ACBUS1	TriSt-PU	Default configuration of ACBUS1 – Input pulled up
ACBUS2	TriSt-PU	Default configuration of ACBUS2 Input pulled up
ACBUS3	TriSt-PU	Default configuration of ACBUS3 – Input pulled up
ACBUS4	TriSt-PU	Default configuration of ACBUS4 – Input pulled up
ACBUS5	TriSt-PU	Default configuration of ACBUS5 – Input pulled up
ACBUS6	TriSt-PU	Default configuration of ACBUS6 – Input pulled up
ACBUS7	TriSt-PD	Default configuration of ACBUS7 – Input pulled down
ACBUS8	TriSt-PU	Default configuration of ACBUS8 – Input pulled up
ACBUS9	TriSt-PU	Default configuration of ACBUS9 – Input pulled up

**Table 7.1 Default External EEPROM Configuration**



## 8 Package Parameters

The FT232H is available in two different packages. The FT232HL is the LQFP-48 option and the FT232HQ is the QFN-48 package option. The solder reflow profile for both packages is described in section 8.3.

### 8.1 FT232HQ, QFN-48 Package Dimensions

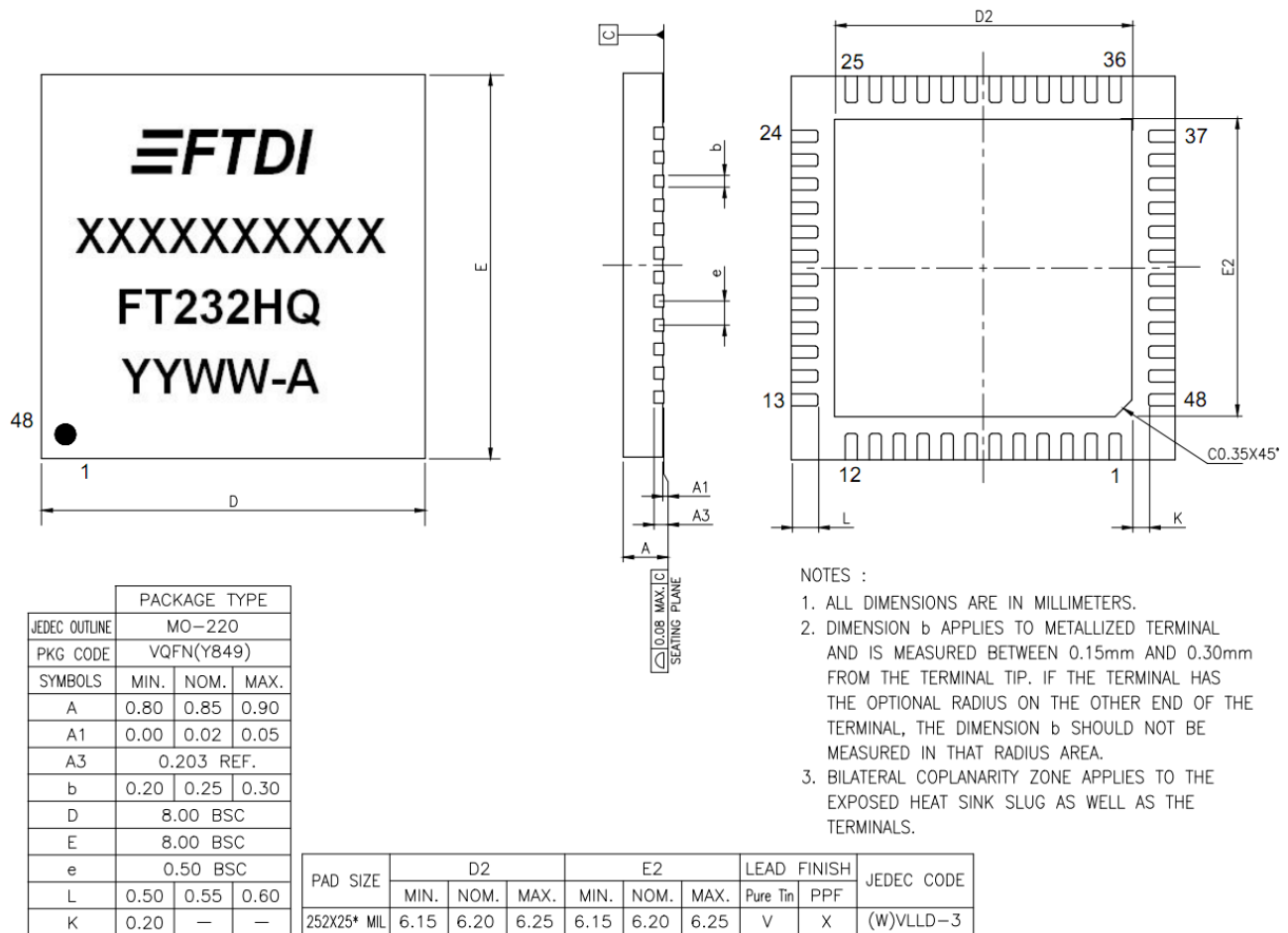
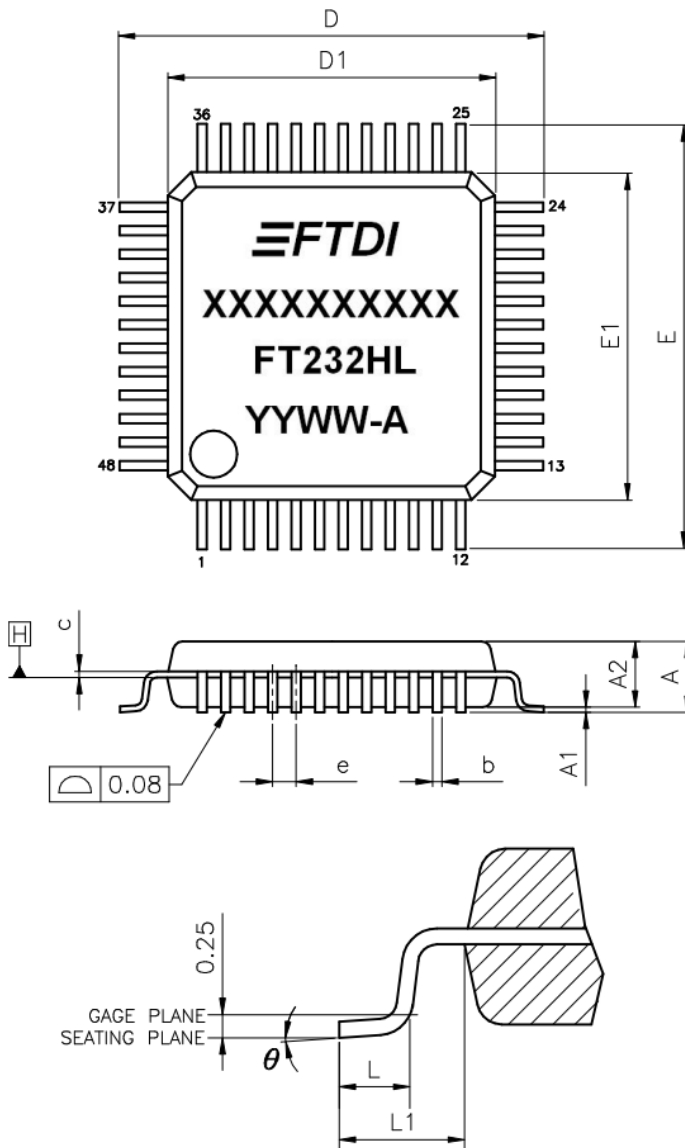

**Figure 8.1 48 pin QFN Package Details**

**Notes:**

1. All dimensions are in mm.
2. The date code format is **YYXX** where XX = 2 digit week number, YY = 2 digit year number. This is followed by the revision number.
3. The code **XXXXXXXX** is the manufacturing LOT code.
4. The central soldering pad is floating. Connect it to GND.

## 8.2 FT232HL, LQFP-48 Package Dimensions



VARIATIONS (ALL DIMENSIONS SHOWN IN MM)

SYMBOLS	MIN.	NOM.	MAX.
A	--	--	1.60
A1	0.05	--	0.15
A2	1.35	1.40	1.45
b	0.17	0.22	0.27
c	0.09	--	0.20
D	9.00 BSC		
D1	7.00 BSC		
E	9.00 BSC		
E1	7.00 BSC		
e	0.50 BSC		
L	0.45	0.60	0.75
L1	1.00 REF		
$\theta$	0°	3.5°	7°

NOTES:

1. JEDEC OUTLINE : MS-026 BBC
2. DATUM PLANE [H] IS LOCATED AT THE BOTTOM OF THE MOLD PARTING LINE COINCIDENT WITH WHERE THE LEAD EXITS THE BODY.
3. DIMENSIONS D1 AND E1 DO NOT INCLUDE MOLD PROTRUSION. ALLOWABLE PROTRUSION IS 0.25 mm PER SIDE. DIMENSIONS D1 AND E1 DO INCLUDE MOLD MISMATCH AND ARE DETERMINED AT DATUM PLANE [H].
4. DIMENSION b DOES NOT INCLUDE DAMBAR PROTRUSION.

**Figure 8.2 48 pin LQFP Package Details**

**Notes:**

1. All dimensions are in mm.
2. The date code format is **YYXX** where XX = 2 digit week number, YY = 2 digit year number. This is followed by the revision number.
3. The code **XXXXXXXX** is the manufacturing LOT code.

### 8.3 Solder Reflow Profile

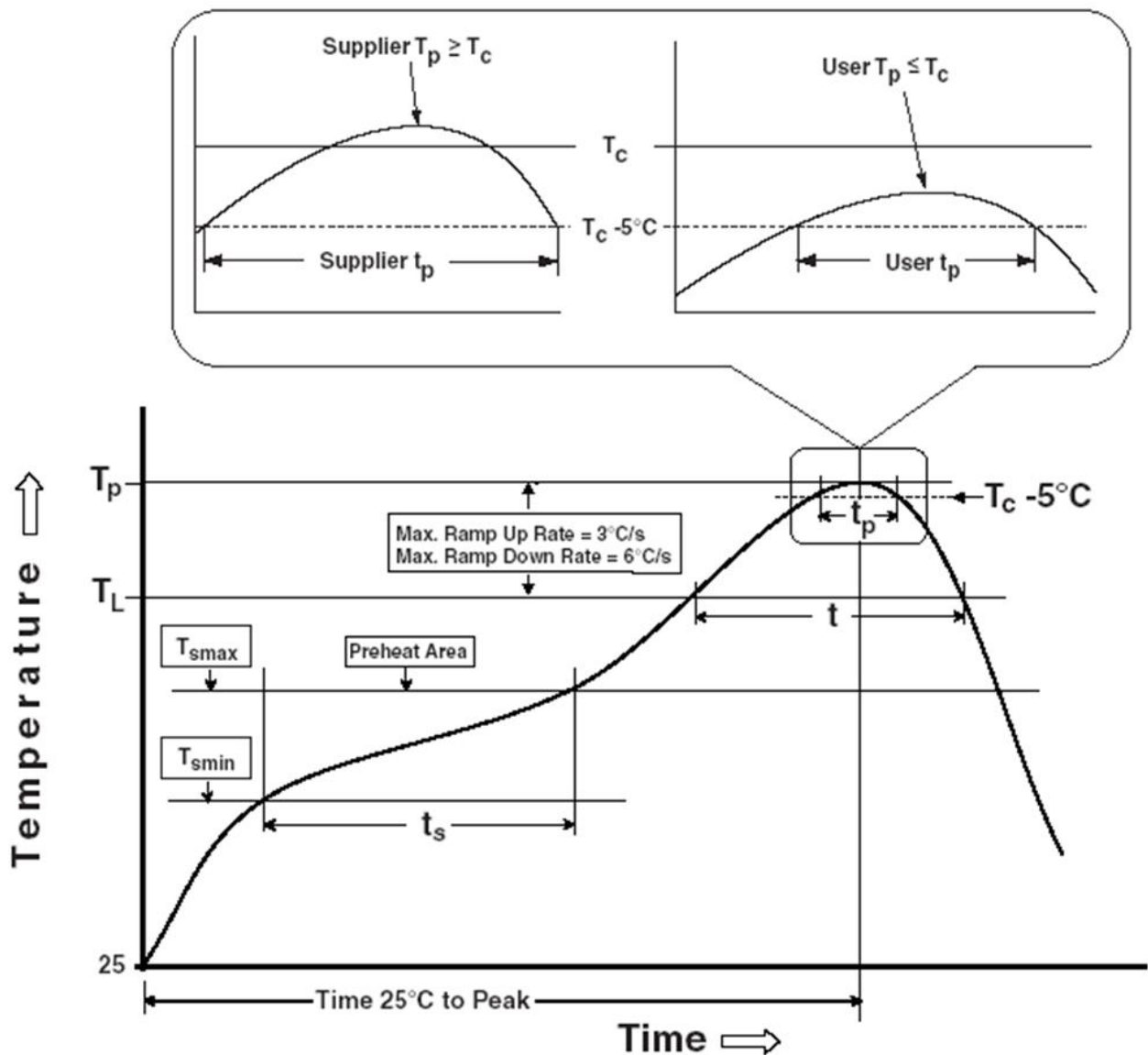

Figure 8.3 48 pin LQFP and QFN Reflow Solder Profile

Profile Feature	Pb Free Solder Process (green material)	SnPb Eutectic and Pb free (non green material) Solder Process
Average Ramp Up Rate ( $T_s$ to $T_p$ )	3°C / second Max.	3°C / Second Max.
Preheat - Temperature Min ( $T_s$ Min.) - Temperature Max ( $T_s$ Max.) - Time ( $t_s$ Min to $t_s$ Max)	150°C 200°C 60 to 120 seconds	100°C 150°C 60 to 120 seconds
Time Maintained Above Critical Temperature $T_L$ : - Temperature ( $T_L$ ) - Time ( $t_L$ )	217°C 60 to 150 seconds	183°C to 150 seconds
Peak Temperature ( $T_p$ )	260°C	60

Time within 5°C of actual Peak Temperature ( $t_p$ )	30 to 40 seconds	20 to 40 seconds
Ramp Down Rate	6°C / second Max.	6°C / second Max.
Time for T= 25°C to Peak Temperature, $T_p$	8 minutes Max.	6 minutes Max.

**Table 8.1 Reflow Profile Parameter Values**

<b>SnPb Eutectic and Pb free (non green material)</b>		
Package Thickness	Volume mm <sup>3</sup> < 350	Volume mm <sup>3</sup> ≥ 350
< 2.5 mm	235 +5/-0 deg C	220 +5/-0 deg C
≥ 2.5 mm	220 +5/-0 deg C	220 +5/-0 deg C
<b>Pb Free (green material) = 260 +5/-0 deg C</b>		

**Table 8.2 Package Reflow Peak Temperature**

## 9 Contact Information

### Head Office – Glasgow, UK

Future Technology Devices International Limited  
Unit 1, 2 Seaward Place, Centurion Business Park  
Glasgow G41 1HH  
United Kingdom  
Tel: +44 (0) 141 429 2777  
Fax: +44 (0) 141 429 2758

E-mail (Sales) [sales1@ftdichip.com](mailto:sales1@ftdichip.com)  
E-mail (Support) [support1@ftdichip.com](mailto:support1@ftdichip.com)  
E-mail (General Enquiries) [admin1@ftdichip.com](mailto:admin1@ftdichip.com)

### Branch Office – Tigard, Oregon, USA

Future Technology Devices International Limited  
(USA)  
7130 SW Fir Loop  
Tigard, OR 97223-8160  
USA  
Tel: +1 (503) 547 0988  
Fax: +1 (503) 547 0987

E-Mail (Sales) [us.sales@ftdichip.com](mailto:us.sales@ftdichip.com)  
E-Mail (Support) [us.support@ftdichip.com](mailto:us.support@ftdichip.com)  
E-Mail (General Enquiries) [us.admin@ftdichip.com](mailto:us.admin@ftdichip.com)

### Branch Office – Taipei, Taiwan

Future Technology Devices International Limited  
(Taiwan)  
2F, No. 516, Sec. 1, NeiHu Road  
Taipei 114  
Taiwan, R.O.C.  
Tel: +886 (0) 2 8797 1330  
Fax: +886 (0) 2 8751 9737

E-mail (Sales) [tw.sales1@ftdichip.com](mailto:tw.sales1@ftdichip.com)  
E-mail (Support) [tw.support1@ftdichip.com](mailto:tw.support1@ftdichip.com)  
E-mail (General Enquiries) [tw.admin1@ftdichip.com](mailto:tw.admin1@ftdichip.com)

### Branch Office – Shanghai, China

Future Technology Devices International Limited  
(China)  
Room 1103, No. 666 West Huaihai Road,  
Shanghai, 200052  
China  
Tel: +86 21 62351596  
Fax: +86 21 62351595

E-mail (Sales) [cn.sales@ftdichip.com](mailto:cn.sales@ftdichip.com)  
E-mail (Support) [cn.support@ftdichip.com](mailto:cn.support@ftdichip.com)  
E-mail (General Enquiries) [cn.admin@ftdichip.com](mailto:cn.admin@ftdichip.com)

### Web Site

<http://ftdichip.com>

### Distributor and Sales Representatives

Please visit the Sales Network page of the [FTDI Web site](#) for the contact details of our distributor(s) and sales representative(s) in your country.

System and equipment manufacturers and designers are responsible to ensure that their systems, and any Future Technology Devices International Ltd (FTDI) devices incorporated in their systems, meet all applicable safety, regulatory and system-level performance requirements. All application-related information in this document (including application descriptions, suggested FTDI devices and other materials) is provided for reference only. While FTDI has taken care to assure it is accurate, this information is subject to customer confirmation, and FTDI disclaims all liability for system designs and for any applications assistance provided by FTDI. Use of FTDI devices in life support and/or safety applications is entirely at the user's risk, and the user agrees to defend, indemnify and hold harmless FTDI from any and all damages, claims, suits or expense resulting from such use. This document is subject to change without notice. No freedom to use patents or other intellectual property rights is implied by the publication of this document. Neither the whole nor any part of the information contained in, or the product described in this document, may be adapted or reproduced in any material or electronic form without the prior written consent of the copyright holder. Future Technology Devices International Ltd, Unit 1, 2 Seaward Place, Centurion Business Park, Glasgow G41 1HH, United Kingdom. Scotland Registered Company Number: SC136640

## Appendix A – References

### Document References

[AN\\_108 – Command Processor for MPSSE and MCU Host Bus Emulation Modes](#)

[AN\\_113 – Interfacing FT2232H Hi-Speed Devices to I2C Bus](#)

[AN\\_114 – Interfacing FT2232H Hi-Speed Devices to SPI Bus](#)

[AN\\_129 – Interfacing FT2232H Hi-Speed Devices to a JTAG TAP](#)

[AN\\_135 – MPSSE Basics](#)

[AN\\_167 FT1248 Parallel Serial Interface Basics](#)

### Acronyms and Abbreviations

Terms	Description
CPU	Central Processing Unit
EEPROM	Electrically Erasable Programmable Read Only Memory
ESD	Electrostatic Discharge
FIFO	First In First Out
I2C	Inter-Integrated Circuit
LDO	Low Drop Out
LED	Light Emitting Diode
LSB	Least Significant Bit First
LQFP	Low Profile Quad Flat Pack
MPSSE	Multi- Protocol Synchronous Serial Engines
QFN	Quad Flat Non-leaded package
SPI	Serial Peripheral Interface
TTL	Transistor-Transistor Logic
USB	Universal Serial Bus
UART	Universal Asynchronous Receiver / Transmitter
UTMI	Universal Transceiver Macrocell Interface

## Appendix B – List of Figures and Tables

### List of Tables

Table 3.1 Power and Ground .....	10
Table 3.2 Common Function Pins .....	10
Table 3.3 EEPROM Interface Group .....	11
Table 3.4 UART Interface and ACBUS Group (see note 1) .....	11
Table 3.5 ACBUS Configuration Control .....	12
Table 3.6 UART Configured Pin Descriptions .....	13
Table 3.7 FT245 Synchronous FIFO Configured Pin Descriptions .....	14
Table 3.8 FT245 Style Asynchronous FIFO Configured Pin Descriptions .....	15
Table 3.9 Synchronous or Asynchronous Bit-Bang Configured Pin Descriptions .....	15
Table 3.10 MPSSE Configured Pin Descriptions .....	16
Table 3.11 Fast Serial Interface Configured Pin Descriptions.....	16
Table 3.12 CPU-style FIFO Interface Configured Pin Descriptions .....	17
Table 3.13 FT1248 Configured Pin Descriptions .....	17
Table 4.1 FT245 Synchronous FIFO Interface Signal Timings .....	24
Table 4.2 Asynchronous FIFO Timings (based on standard drive level outputs).....	25
Table 4.3 Synchronous Bit-Bang Mode Timing Interface Example Timings.....	30
Table 4.4 MPSSE Signal Timings .....	31
Table 4.5 Fast Serial Interface Signal Timings .....	33
Table 4.6 CPU-Style FIFO Interface Operation Select.....	35
Table 4.7 CPU-Style FIFO Interface Operation Read Status Description.....	36
Table 4.8 CPU-Style FIFO Interface Operation Signal Timing .....	36
Table 4.9 Configuration Using EEPROM and Application Software .....	39
Table 5.1 Absolute Maximum Ratings .....	40
Table 5.2 Operating Voltage and Current (except PHY) .....	40
Table 5.3 I/O Pin Characteristics VCCIO = +3.3V (except USB PHY pins) .....	41
Table 5.4 PHY Operating Voltage and Current.....	41
Table 5.5 PHY I/O Pin Characteristics .....	41
Table 5.6 ESD Tolerance.....	42
Table 6.1 OSCI Input characteristics .....	46
Table 7.1 Default External EEPROM Configuration .....	48
Table 8.1 Reflow Profile Parameter Values .....	52
Table 8.2 Package Reflow Peak Temperature.....	52

## List of Figures

Figure 2.1 FT232H Block Diagram .....	4
Figure 3.1 FT232H Schematic Symbol .....	8
Figure 4.1 RS232 Configuration .....	20
Figure 4.2 Dual RS422 Configuration.....	21
Figure 4.3 Dual RS485 Configuration.....	22
Figure 4.4 FT245 Synchronous FIFO Interface Signal Waveforms .....	23
Figure 4.5 FT245 Asynchronous FIFO Interface READ Signal Waveforms .....	25
Figure 4.6 FT245 Asynchronous FIFO Interface WRITE Signal Waveforms .....	25
Figure 4.7 FT1248 Bus with Single Master and Slave. ....	26
Figure 4.8 FT1248 Basic Waveform Protocol.....	26
Figure 4.9 FT1248 Command Structure .....	27
Figure 4.10 FT1248 1-bit Mode Protocol (WRITE).....	28
Figure 4.11 FT1248 1-bit Mode Protocol (READ) .....	28
Figure 4.12 Synchronous Bit-Bang Mode Timing Interface Example.....	30
Figure 4.13- Bit-bang Mode Dataflow Illustration Diagram .....	31
Figure 4.14 MPSSE Signal Waveforms .....	31
Figure 4.15 Adaptive Clocking Interconnect.....	32
Figure 4.16 Adaptive Clocking Waveform .....	32
Figure 4.17 Fast Serial Interface Signal Waveforms.....	33
Figure 4.18 Fast Serial Interface Output Data.....	34
Figure 4.19 Fast Serial Interface Input Data.....	34
Figure 4.20 Fast Serial Interface Example .....	35
Figure 4.21 CPU-Style FIFO Interface Operation Signal Waveforms .....	36
Figure 4.22 CPU-Style FIFO Interface Example .....	37
Figure 4.23 Dual LED UART Configuration .....	37
Figure 4.24 Single LED UART Configuration.....	38
Figure 4.25 Using SIWU# .....	38
Figure 6.1 Bus Powered Configuration Example 1.....	43
Figure 6.2 Self-Powered Configuration Example 1 .....	44
Figure 6.3 Self-Powered Configuration Example 2 .....	45
Figure 6.4 Recommended FT232H Oscillator Configuration.....	46
Figure 7.1 EEPROM Interface.....	47
Figure 8.1 48 pin QFN Package Details .....	49
Figure 8.2 48 pin LQFP Package Details .....	50
Figure 8.3 48 pin LQFP and QFN Reflow Solder Profile .....	51



## Appendix C – Revision History

Document Title: FT232H Single Channel Hi-Speed USB to Multipurpose UART/FIFO IC Datasheet  
 Document Reference No.: FT\_000288  
 Clearance No.: FTDI #199  
 Product Page: <http://www.ftdichip.com/Products/ICs/FT232H.htm>  
 Document Feedback: [Send Feedback](#)

Revision	Changes	Date
Version 1.0	Initial Release	2011-02-24
Version 1.1	Changes made to ACBUS7 details; Updated the reset line of the schematics; Added USB Compliance logo and TID	2011-04-19
Version 1.2	Corrected TID Number	2011-04-29
Version 1.3	Changed the value of recommended capacitor on the Reset# pin; Changed signal label of WR to WR#	2011-05-16
Version 1.4	Missing #(active low) on WR signal page 8 and page 40; Enhanced recommended schematics.	2011-09-08
Version 1.5	Added Pin 31 ACBUS7 Description (Table 0.1); Added Package Dimension Tolerance in Section 8.2; Added a list of unsupported baud rates to section 4.1 data transfer rate	2011-11-25
Version 1.6	Updated section 1.1, Linux Version; Updated Timing information, Figure 4.21 and Table 4.8; Updated section 7.2 default descriptors	2012-01-25
Version 1.7	Added a note on Section 4.2, EEPROM interface; 93LC46B is not compatible with the FT232H	2012-06-21
Version 1.8	Modified the IC mark, Figure 8.1 and Figure 8.2; Update contact information	2012-12-13
Version 1.81	Added detail to QFN drawing regarding the center pad; Corrected figure 6.4; Added clarification for which signals are 5V tolerant; Clarified ACBUS default functions on P8	2013-01-04
Version 1.82	Updated ADBUS7 to ACBUS7 on page 10; Added support for Windows 10; Removed year from the copyright information	2016-02-05
Version 1.83	Corrected the typo error in table 3.13	2017-11-22
Version 1.84	Updated Section 6.2.2 (Self-Powered Application Example 2- ACBUS7 pin function)	2018-05-11
Version 1.85	Correct the MPSSE timing spec in table 4.4	2018-07-23
Version 1.9	Updated Figure 8.1 and Figure 8.2 package dimensions	2019-05-27
Version 2.0	Updated Section 3.5.3 header	2019-11-29



## Стандарт Электрон Связь

Мы молодая и активно развивающаяся компания в области поставок электронных компонентов. Мы поставляем электронные компоненты отечественного и импортного производства напрямую от производителей и с крупнейших складов мира.

Благодаря сотрудничеству с мировыми поставщиками мы осуществляем комплексные и плановые поставки широчайшего спектра электронных компонентов.

Собственная эффективная логистика и склад в обеспечивает надежную поставку продукции в точно указанные сроки по всей России.

Мы осуществляем техническую поддержку нашим клиентам и предпродажную проверку качества продукции. На все поставляемые продукты мы предоставляем гарантию .

Осуществляем поставки продукции под контролем ВП МО РФ на предприятия военно-промышленного комплекса России , а также работаем в рамках 275 ФЗ с открытием отдельных счетов в уполномоченном банке. Система менеджмента качества компании соответствует требованиям ГОСТ ISO 9001.

Минимальные сроки поставки, гибкие цены, неограниченный ассортимент и индивидуальный подход к клиентам являются основой для выстраивания долгосрочного и эффективного сотрудничества с предприятиями радиоэлектронной промышленности, предприятиями ВПК и научно-исследовательскими институтами России.

С нами вы становитесь еще успешнее!

### Наши контакты:

**Телефон:** +7 812 627 14 35

**Электронная почта:** [sales@st-electron.ru](mailto:sales@st-electron.ru)

**Адрес:** 198099, Санкт-Петербург,  
Промышленная ул, дом № 19, литера Н,  
помещение 100-Н Офис 331