

# TWR-S08UNIV

---

## User's Manual

Rev. 1

# Table of Contents

<b>1. TWR-S08UNIV and TWR-S08DC Overview .....</b>	<b>4</b>
1.1 Contents.....	5
1.2 Features .....	5
<b>2. Getting Started.....</b>	<b>7</b>
2.1 Reference Documents .....	7
<b>3. Hardware Description .....</b>	<b>7</b>
3.1 Daughter Cards TWR-S08DC-XXX for the TWR-S08UNIV Module.....	8
3.2 System Power.....	9
3.2.1 TWR-S08DC-XXX Daughter Cards 3V/5V Switch .....	9
3.3 Debug Interface .....	9
3.3.1 OSBDM .....	9
3.3.2 BDM Multilink 6-PIN.....	10
3.4 Potentiometer, Pushbuttons, LEDs, Beeper.....	10
3.5 General Purpose Tower Plug-in (TWRPI) Socket.....	10
3.6 Touch Pad Tower Plug-in (TWRPI) Socket.....	11
3.7 Touch Sensor Tower Plug-in (TWRPI) TWRPI.....	11
<b>4. Software - CodeCreator .....</b>	<b>12</b>
<b>5. DIP Switch Table .....</b>	<b>13</b>
<b>6. Input/Output Connections for Daughter Cards .....</b>	<b>14</b>
<b>7. Tower Elevator Connections .....</b>	<b>14</b>

## List of Figures

Figure 1. Freescale Tower System Overview ..... 4  
 Figure 2. Callouts on the TWR-S08UNIV ..... 6  
 Figure 3. Callouts on TWR-S08UNIV Daughter Cards ..... 6  
 Figure 4. TWR-S08UNIV Block Diagram ..... 8

## List of Tables

Table 1. BDM Multilink 6-PIN Connector Pinout ..... 10  
 Table 2. General Purpose TWRPI socket pinout ..... 10  
 Table 3. Touch Pad TWRPI socket pinout ..... 11  
 Table 4. Touch Sensor TWRPI socket pinout ..... 12  
 Table 5. TWR-S08UNIV DIP Switch Table..... 13  
 Table 6. TWR-S08UNIV Primary Connector Pinout..... 14

## Revision History

Revision	Date	Changes
0	Sept 1,2011	Initial Release
1	January 5, 2012	Fixed typos in part numbers for the TWR-UNIV and TWR-UNIV-DEMO

# 1. TWR-S08UNIV and TWR-S08DC Overview

The TWR-S08UNIV is a Tower Controller Module compatible with the Freescale Tower System. It can function as a stand-alone, low-cost platform for the evaluation of the many of our S08/RS08 microcontrollers in conjunction with the TWR-S08DC daughter cards.

The TWR-S08UNIV is available as a stand-alone product or as a kit (TWR-S08UNIV-DEMO) that includes all six original (R)S08 daughter cards. The TWR-S08UNIV can also be combined with other Freescale Tower peripheral modules to create development platforms for a wide variety of applications. Figure 1 provides an overview of the Freescale Tower System.

### Controller Module

- Tower MCU/MPU board
- Works stand-alone or in Tower System
- Features integrated debugging interface for easy programming and run-control via standard USB cable

### Secondary Elevator

- Additional and secondary serial and expansion bus signals
- Standardized signal assignments
- Mounting holes and expansion connectors for side-mounting peripheral boards

### Size

- Tower is approx. 3.5" H x 3.5" W x 3.5" D when fully assembled

### Peripheral Module

- Examples include serial interface module, memory expansion module and Wi-Fi®

### Primary Elevator

- Common serial and expansion bus signals
- Two 2x80 connectors on backside for easy signal access and side-mounting board (LCD module)
- Power regulation circuitry
- Standardized signal assignments
- Mounting holes

### Board Connectors

- Four card-edge connectors
- Uses PCI Express® connectors (x16, 90 mm/ 3.5" long, 164 pins)

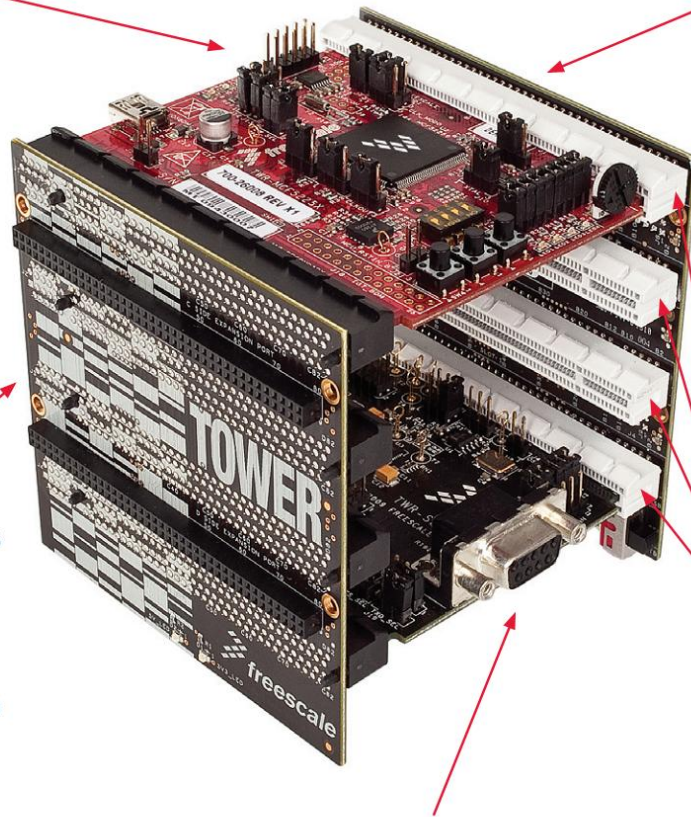

Figure 1. Freescale Tower System Overview

## 1.1 Contents

The TWR-S08UNIV contents include:

- TWR-S08UNIV board assembly
- 3ft USB cable
- Interactive DVD with software installers and documentation
- Quick Start Guide

The TWR-S08UNIV-DEMO contains:

- TWR-RS08DC-KA8
- TWR-S08DC-AC60
- TWR-S08DC-QD4
- TWR-S08DC-QE64
- TWR-S08DC-QG8
- TWR-S08DC-SH8

## 1.2 Features

Figure 2 and Figure 3 show the TWR-S08UNIV with some of the key features called out. The following list summarizes the features of the TWR-S08UNIV Tower Module:

- Tower compatible universal board module
- Interchangeable Daughter Card Sockets for many S08/RS08 microcontrollers
- Touch Tower Plug-in Socket
- Touch Sense Tower Plug-in (TWRPI) socket
- General purpose Tower Plug-in (TWRPI) socket
- On-board OSBDM debug circuit (OSBDM) with virtual serial port
- One (1) user-controllable RGB LED
- Two (2) user pushbutton switches
- Potentiometer
- One (1) user-controllable buzzer



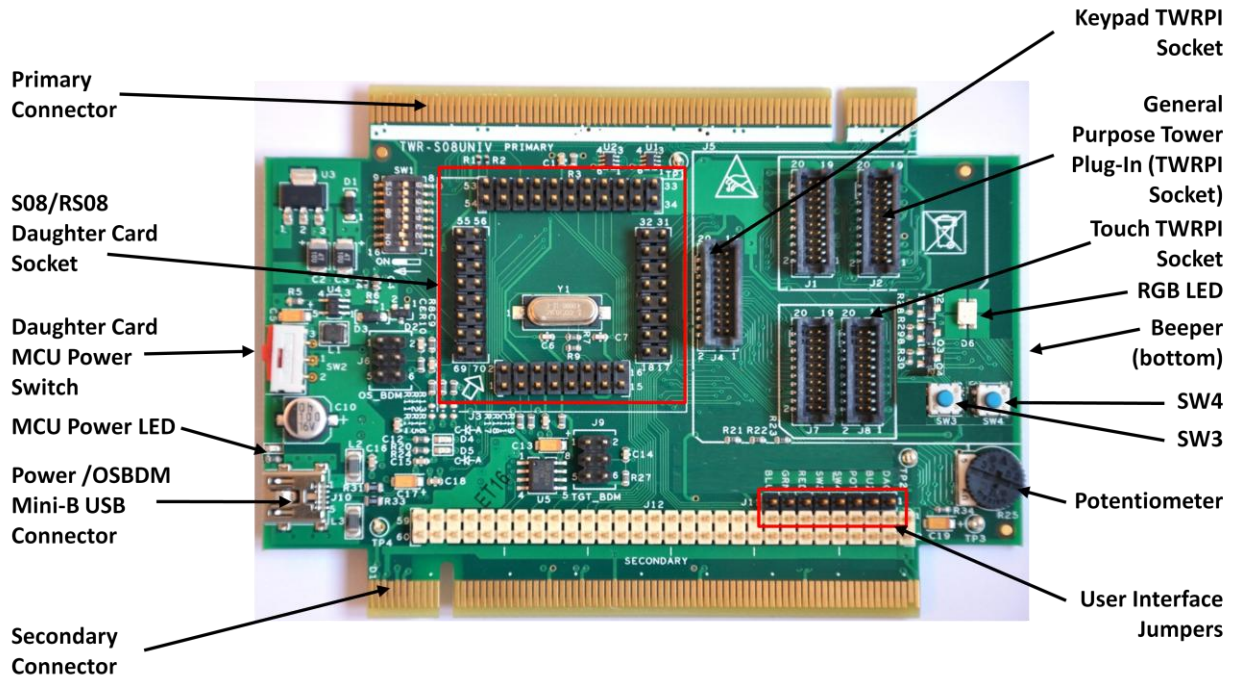

Figure 2. Callouts on the TWR-S08UNIV

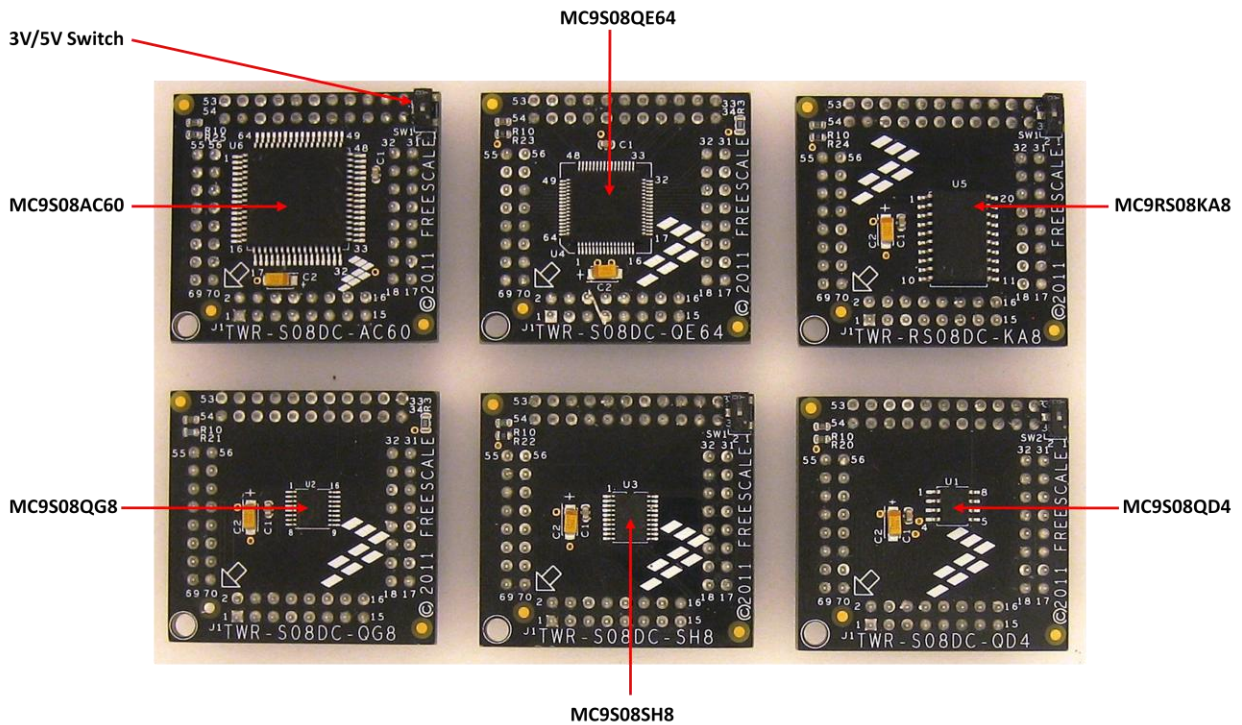

Figure 3. Callouts on TWR-S08UNIV Daughter Cards

## 2. Getting Started

---

Follow the Quick Start Guide found printed in the TWR-S08UNIV box or the interactive DVD for the list of recommended steps for getting started. There are also lab walk-through guides available on the tool support page for the TWR-S08UNIV:

[http://www.freescale.com/webapp/sps/site/prod\\_summary.jsp?code=TWR-S08UNIV](http://www.freescale.com/webapp/sps/site/prod_summary.jsp?code=TWR-S08UNIV).

### 2.1 Reference Documents

The documents listed below should be referenced for more information on the Kinetis family, Tower System, and MCU Modules. These can be found in the documentation section of the TWR-S08UNIV tool support page ([http://www.freescale.com/webapp/sps/site/prod\\_summary.jsp?code=TWR-S08UNIV](http://www.freescale.com/webapp/sps/site/prod_summary.jsp?code=TWR-S08UNIV)).

- TWR-S08UNIV-QSG: Quick Start Guide
- TWR- S08UNIV -SCH: Schematics
- TWR- S08DC-AC60: Schematics
- TWR- S08DC-QE64: Schematics
- TWR- S08DC-SH8: Schematics
- TWR- S08DC-QG8: Schematics
- TWR- S08DC-QD4: Schematics
- TWR- RS08DC-KA8: Schematics
- TWR- S08UNIV-DC Master Pinout
- Tower Configuration Tool

## 3. Hardware Description

---

The TWR-S08UNIV is a Tower Controller Module featuring a very easy way to switch between different S08/RS08 MCUs. The TWR-S08UNIV module can be used in stand-alone mode or connected to the Tower System. The TWR-S08UNIV module must have a Daughter Card TWR-S08DC-XXX plugged in to operate properly. Each TWR-S08DC-XXX daughter card will have a unique ID associated with the MCU on the daughter card. Each 5V MCU daughter card will have the option to select between 3V and 5V setting, which will control the system voltage on the TWR-S08UNIV module. Figure 4 shows a block diagram of the TWR-S08UNIV. The following sections describe the hardware in more detail.



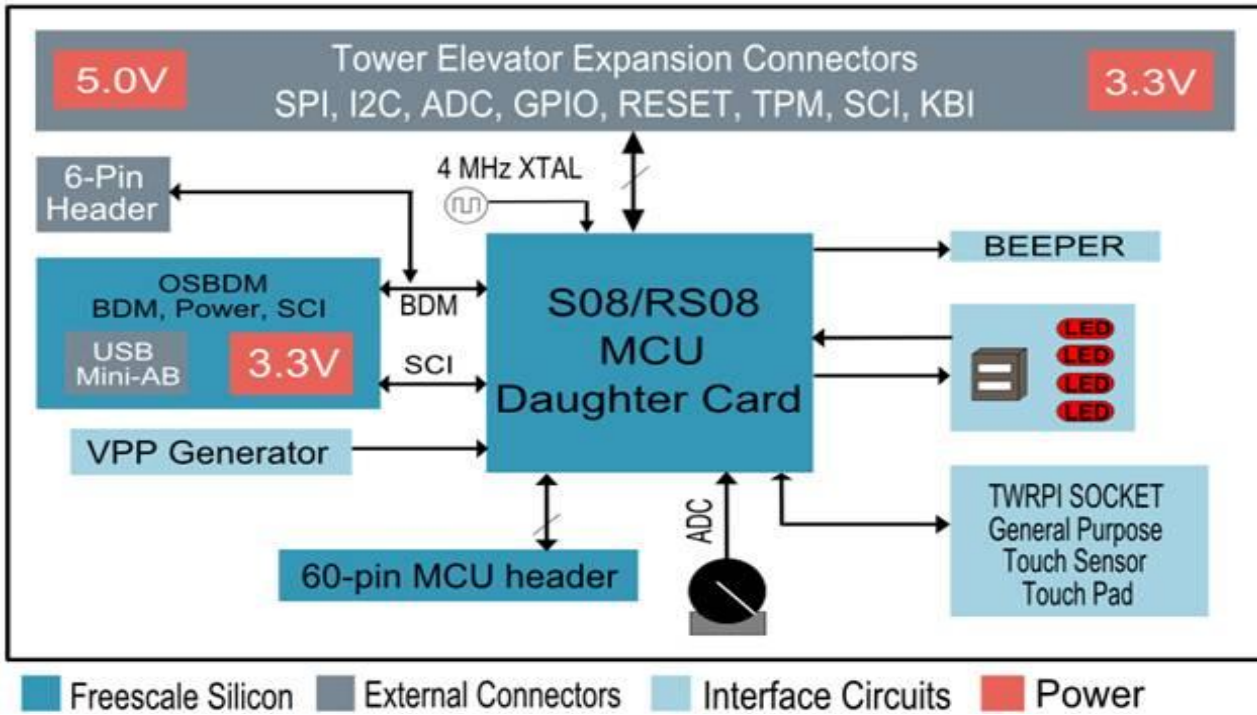
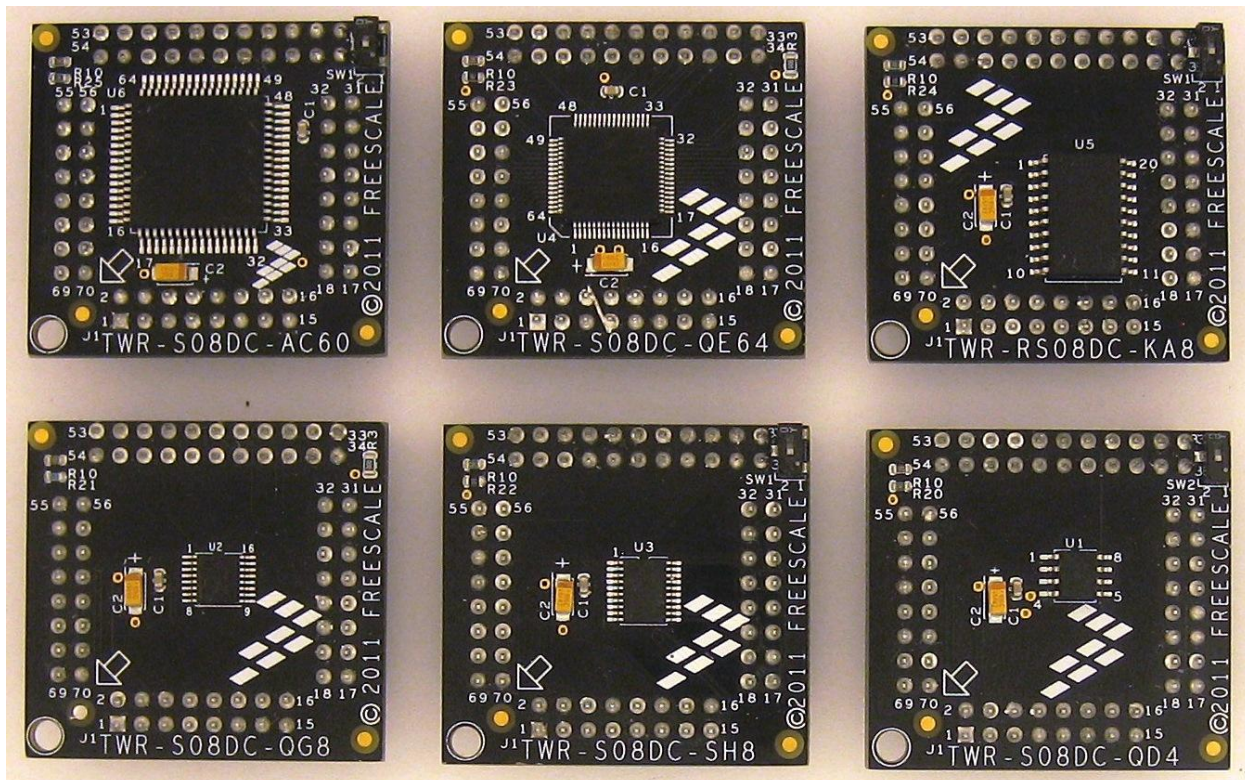

Figure 4. TWR-S08UNIV Block Diagram

### 3.1 Daughter Cards TWR-S08DC-XXX for the TWR-S08UNIV Module

The TWR-S08UNIV module features a universal socket in the middle of the board which can be interchanged with several of the TWR-S08DC-XXX.





The TWR-S08UNIV-DEMO kit features:

- One MC9S08AC60 single MCU with a hardware unique ID for this daughter card
- One MC9S08QE64 single MCU with a hardware unique ID for this daughter card
- One MC9S08SH8 single MCU with a hardware unique ID for this daughter card
- One MC9S08QG8 single MCU with a hardware unique ID for this daughter card
- One MC9S08QD4 single MCU with a hardware unique ID for this daughter card
- One MC9RS08KA8 single MCU with a hardware unique ID for this daughter card

## 3.2 System Power

In stand-alone operation, the main power source for the TWR-S08UNIV module is derived from the 5.0V input from either the USB mini-B connector, or the debug header, J12-45. A low-dropout regulator provides a 3.3V supply from the 5.0V input voltage. Refer to sheet 4 of the TWR-S08UNIV schematics for more details.

When installed into a Tower System, the TWR-S08UNIV can be powered from either an on-board source or from another source in the assembled Tower System. If both the on-board and off-board sources are available, the TWR-S08UNIV will default to the off-board source.

### 3.2.1 TWR-S08DC-XXX Daughter Cards 3V/5V Switch

The 3V/5V switch allows the daughter card to control the voltage supply to the TWR-S08UNIV module. The daughter cards without the 3V/5V switch are hard wired to a 3.3V supply voltage to the TWR-S08UNIV module. These are the selected daughter cards with the 3V/5V switch:

- TWR-S08DC-AC60
- TWR-S08DC-SH8
- TWR-S08DC-QD4
- TWR-RS08DC-KA8

## 3.3 Debug Interface

There are two debug interface options provided: the on-board OSBDM circuit and an external 6-pin interface header for the P&E Microsystems Multilink tools.

### 3.3.1 OSBDM

An on-board MC9S08JM60 based Open Source Background Debug (OSBDM) circuit provides an OSBDM debug interface to the MCUs. A standard USB A male to Mini-B male cable (provided) can be used for debugging via the USB connector, J10. The OSBDM interface also provides a USB to serial bridge. Drivers for the OSJTAG interface are provided in the *P&E Micro Tower Toolkit* (available on the included DVD and from P&E at <http://www.pemicro.com/osbdm>).

**Note:** The port pin PTE0 (TXD1) connected to the OSBDM USB-to-serial bridge is also connected the TWR-ELEV and the J12 Header. Refer to 0 “header J12.” and Table 5 “TWR-S08UNIV DIP Switch Table” for more information.

### 3.3.2 BDM Multilink 6-PIN

The BDM Multilink is a 6-pin (3x2) connector (0.1"Pitch, 0.1" Row) connector providing access to the target daughter card MCU to program and debug the microcontroller. The BDM Multilink 6-pin connections to the debug connector, J9, are shown in Table 1.

Table 1. BDM Multilink 6-PIN Connector Pinout

Pin	Function	TWR-S08UNIV Connection
1	BGND	3.3V MCU supply (P3V3_MCU)
2	GND	GND
3	NC	No Connection
4	nRESET	nRESET
5	NC	No Connection
6	VDD	3Vor 5V, depending on the daughter card switch position

### 3.4 Potentiometer, Pushbuttons, LEDs, Beeper

The TWR-S08UNIV features two pushbutton switches connected to GPIO/interrupt signals, one RGB (red, green, blue) LED connected to GPIO, and a potentiometer connected to an ADC input signal, and a beeper connected to a timer channel. Refer to Section 6 “Input/Output Connections for Daughter Cards” for information about which port pins are connected to these features.

### 3.5 General Purpose Tower Plug-in (TWRPI) Socket

The TWR-S08UNIV features a General Purpose TWRPI socket that can accept a variety of different Tower Plug-in modules featuring sensors, RF transceivers, accelerometers, and more. The General Purpose TWRPI socket provides access to I2C, SPI, IRQs, GPIOs, timers, analog conversion signals, and voltage supplies. The pinout for the TWRPI Socket is defined in Table 2.

Refer to Section 6 “Input/Output Connections for Daughter Cards” for the specific TWR-S08UNIV pin connections to the General Purpose TWRPI socket.

Table 2. General Purpose TWRPI socket pinout

Left-side 2x10 Connector		Right-side 2x10 Connector	
Pin	Description	Pin	Description
1	5V VCC	1	GND
2	3.3 V VCC	2	GND
3	GND	3	I2C: SCL
4	3.3V VDDA	4	I2C: SDA
5	VSS (Analog GND)	5	GND
6	VSS (Analog GND)	6	GND
7	VSS (Analog GND)	7	GND
8	ADC: Analog 0	8	GND
9	ADC: Analog 1	9	SPI: MISO
10	VSS (Analog GND)	10	SPI: MOSI
11	VSS (Analog GND)	11	SPI: SS
12	ADC: Analog 2	12	SPI: CLK
13	VSS (Analog GND)	13	GND
14	VSS (Analog GND)	14	GND

15	GND	15	GPIO: GPIO0/IRQ
16	GND	16	GPIO: GPIO1/IRQ
17	<b>NC</b>	17	GPIO: GPIO2
18	<b>NC</b>	18	GPIO: GPIO3
19	GND	19	GPIO: GPIO4/Timer
20	<b>NC</b>	20	GPIO: GPIO5/Timer

### 3.6 Touch Pad Tower Plug-in (TWRPI) Socket

There are twelve electrodes GPIO inputs are connected to a Touch Tower Plug-in (TWRPI) socket that can accept Touch TWRPI daughter cards that may feature keypads, rotary dials, sliders, etc.

The pinout for the Touch Pad TWRPI socket is defined in Table 3. Refer to Section 6 “Input/Output Connections for Daughter Cards” for the specific TWR-S08UNIV pin connections to the Touch TWRPI socket.

Table 3. Touch Pad TWRPI socket pinout

Pin	Description
1	5V VCC
2	3.3 V VCC
3	Electrode 0
4	3.3V VDDA
5	Electrode 1
6	VSS (Analog GND)
7	Electrode 2
8	Electrode 3
9	Electrode 4
10	Electrode 5
11	Electrode 6
12	Electrode 7
13	Electrode 8
14	Electrode 9
15	Electrode 10
16	Electrode 11
17	<b>NC</b>
18	<b>NC</b>
19	GND
20	<b>NC</b>

### 3.7 Touch Sensor Tower Plug-in (TWRPI) TWRPI

The TWR-S08UNIV features a Touch Sensor TWRPI socket that can accept a variety of different Tower Plug-in modules featuring the MPR031 and MPR121 Touch sensors, and TSS software using GPIO. The pinout for the Touch Sensor TWRPI Socket is defined in Table 24.

Table 4. Touch Sensor TWRPI socket pinout

Left-side 2x10 Connector		Right-side 2x10 Connector	
Pin	Description	Pin	Description
1	5V VCC	1	GND
2	3.3 V VCC	2	GND
3	Electrode IN 0	3	I2C: SCL
4	3.3V VDDA	4	I2C: SDA
5	Electrode IN 1	5	Electrode OUT 0
6	VSS (Analog GND)	6	Electrode OUT
7	Electrode IN 2	7	Electrode OUT
8	Electrode IN 3	8	Electrode OUT
9	Electrode IN 4	9	Electrode OUT
10	Electrode IN 5	10	Electrode OUT
11	Electrode IN 6	11	Electrode OUT
12	Electrode IN 7	12	Electrode OUT
13	Electrode IN 8	13	Electrode OUT
14	Electrode IN 9	14	Electrode OUT
15	Electrode IN 10	15	Electrode OUT
16	Electrode IN 11	16	Electrode OUT
17	<b>NC</b>	17	GPIO: GPIO0/IRQ
18	<b>NC</b>	18	<b>NC</b>
19	GND	19	<b>NC</b>
20	<b>NC</b>	20	GND

## 4. Software - CodeCreator

The CodeCreator Software is a quick and easy to use GUI, which allows one to create an RS08/S08 peripheral module “C” code example, in under 10 seconds. This demonstration RS08/S08 code can then be loaded into the selected TWR-S08DC-XXX daughter card board.

Download and unzip the “FREESCALE\_CODECREATOR\_V15” from the web.

[http://www.freescale.com/webapp/sps/site/prod\\_summary.jsp?code=TWR-S08UNIV](http://www.freescale.com/webapp/sps/site/prod_summary.jsp?code=TWR-S08UNIV)



### Step 1.

Launch the CC15.exe.

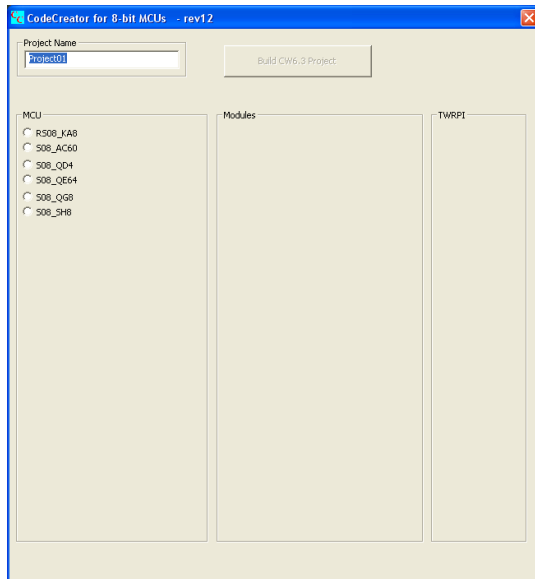

### Step 2.

Select the MCU, Module, and enter a Project Name. Then hit “Build CW6.3 Project”.

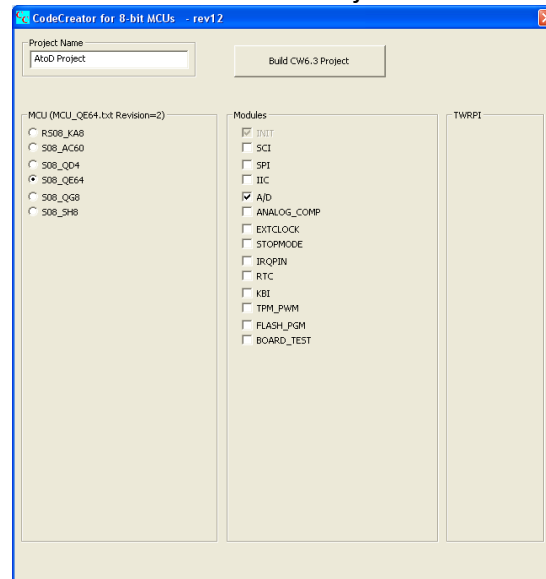

### Step 3.

Import project into CW10.1 using the “Import CodeWarrior Classic” or double-click on the <example>.mcp file in the created project were CC15.exe is located.

## 5. DIP Switch Table

There are dip switch settings on the TWR-S08UNIV board that provide configuration for the RXD connection to the MCU, SPI Chip Select (CS), and reprogramming the JM60 OSBDM Firmware. Refer to the following table for details. The default DIP switch settings are shown in bold with asterisks.

Table 5. TWR-S08UNIV DIP Switch Table

Jumper	Feature	Switch Setting	Pin Function
SW1-1**	RXD connection to Target MCU, J3-38	ON <b>OFF*</b>	RXD connection from Header J12-44 Connection OPEN
SW1-2**	RXD connection to Target MCU, J3-38	<b>ON*</b> OFF	TXD connection from JM60 OSBDM Virtual COM Port Connection CLOSED
SW1-3**	RXD connection to Target MCU, J3-38	ON <b>OFF*</b>	RXD connection from Elevator A41 Connection OPEN
SW1-4	SPI Chip Select to TWR-Elevators	ON <b>OFF*</b>	SPI1 CS0 Connection OPEN
SW1-5	SPI Chip Select to TWR-Elevators	ON <b>OFF*</b>	SPI1 CS1 Connection OPEN

Jumper	Feature	Switch Setting	Pin Function
SW1-6	SPI Chip Select to TWR-Elevators	ON <b>OFF*</b>	SPI0 CS0 Connection OPEN
SW1-7	SPI Chip Select to TWR-Elevators	ON <b>OFF*</b>	SPI0 CS1 Connection OPEN
SW1-8	OSBDM Bootloader Enable/Disable	ON <b>OFF*</b>	ON=JM60 in Bootloader mode, OFF=normal Connection OPEN

\*Default Factory Setting

\*\*Only one of the three SW1-1, SW1-2, and SW1-3 connections should be ON.

## 6. Input/Output Connections for Daughter Cards

All of the input/output signals from all of the daughter cards are available on the header J12. Please refer to the document “TWR-S08UNIV-DC MASTER\_PINOUT.pdf” available on the Freescale website: [http://www.freescale.com/webapp/sps/site/prod\\_summary.jsp?code=TWR-S08UNIV](http://www.freescale.com/webapp/sps/site/prod_summary.jsp?code=TWR-S08UNIV)

## 7. Tower Elevator Connections

The TWR-S08UNIV features two expansion card-edge connectors that interface to the Primary and Secondary Elevator boards in a Tower system. The Primary Connector (comprised of sides A and B) is utilized by the TWR-S08UNIV while the Secondary Connector (comprised of sides C and D) only makes connections to the GND pins. Table 6 provides the pinout for the Primary Connector.

Table 6. TWR-S08UNIV Primary Connector Pinout

Pin #	Side B		Pin #	Side A	
	Name	Usage		Name	Usage
B1	<b>5V</b>	<b>5.0V Power</b>	A1	<b>5V</b>	<b>5.0V Power</b>
B2	<b>GND</b>	<b>Ground</b>	A2	<b>GND</b>	<b>Ground</b>
B3	<b>3.3V</b>	<b>3.3V Power</b>	A3	<b>3.3V</b>	<b>3.3V Power</b>
B4	<b>NC</b>	<b>NC</b>	A4	<b>NC</b>	<b>NC</b>
B5	<b>GND</b>	<b>Ground</b>	A5	<b>GND</b>	<b>Ground</b>
B6	<b>GND</b>	<b>Ground</b>	A6	<b>GND</b>	<b>Ground</b>
B7	ELE_SCLK	J3-2	A7	ELE_SCL	J3-4
B8	ELE_SDHC_CS1	J3-49	A8	ELE_SDA	J3-3
B9	ELE_SDHC_CS0	J3-49	A9	<b>NC</b>	<b>NC</b>
B10	ELE_MOSI	J3-1	A10	<b>NC</b>	<b>NC</b>
B11	ELE_MISO	J3-50	A11	<b>NC</b>	<b>NC</b>
B12	<b>NC</b>	<b>NC</b>	A12	<b>NC</b>	<b>NC</b>
B13	<b>NC</b>	<b>NC</b>	A13	<b>NC</b>	<b>NC</b>
B14	<b>NC</b>	<b>NC</b>	A14	<b>NC</b>	<b>NC</b>
B15	<b>NC</b>	<b>NC</b>	A15	<b>NC</b>	<b>NC</b>
B16	<b>NC</b>	<b>NC</b>	A16	<b>NC</b>	<b>NC</b>
B17	<b>NC</b>	<b>NC</b>	A17	<b>NC</b>	<b>NC</b>
B18	<b>NC</b>	<b>NC</b>	A18	<b>NC</b>	<b>NC</b>
B19	<b>NC</b>	<b>NC</b>	A19	<b>NC</b>	<b>NC</b>

Pin #	Side B		Pin #	Side A	
	Name	Usage		Name	Usage
B20	NC	NC	A20	NC	NC
B21	NC	NC	A21	NC	NC
B22	NC	NC	A22	NC	NC
B23	NC	NC	A23	NC	NC
B24	NC	NC	A24	NC	NC
B25	NC	NC	A25	NC	NC
B26	GND	Ground	A26	GND	Ground
B27	NC	NC	A27	NC	NC
B28	NC	NC	A28	ELE_ANA2	J3-27
B29	NC	NC	A29	ELE_ANA1	J3-28
B30	NC	NC	A30	ELE_ANA0	J3-29
B31	GND	Ground	A31	GND	Ground
B32	NC	NC	A32	NC	NC
B33	NC	NC	A33	ELE_GPIO5TPM	J3-42
B34	NC	NC	A34	ELE_GPIO4TPM	J3-67
B35	NC	NC	A35	NC	NC
B36	3.3V	3.3V Power	A36	3.3V	3.3V Power
B37	NC	NC	A37	NC	NC
B38	NC	NC	A38	NC	NC
B39	NC	NC	A39	NC	NC
B40	NC	NC	A40	NC	NC
B41	NC	NC	A41	RXD_ELEV	J3-38
B42	NC	NC	A42	TXD_ELEV	J3-37
B43	NC	NC	A43	NC	NC
B44	ELE_MISO	J3-50	A44	NC	NC
B45	ELE_MOSI	J3-1	A45	NC	NC
B46	ELE_SPI_CS0	J3-49	A46	NC	NC
B47	ELE_SPI_CS1	J3-49	A47	NC	NC
B48	ELE_SCLK	J3-2	A48	NC	NC
B49	GND	Ground	A49	GND	Ground
B50	ELE_SCL	J3-4	A50	NC	NC
B51	ELE_SDA	J3-3	A51	NC	NC
B52	NC	NC	A52	NC	NC
B53	NC	NC	A53	NC	NC
B54	NC	NC	A54	NC	NC
B55	NC	NC	A55	NC	NC
B56	NC	NC	A56	NC	NC
B57	NC	NC	A57	NC	NC
B58	NC	NC	A58	NC	NC
B59	NC	NC	A59	NC	NC
B60	NC	NC	A60	NC	NC
B61	NC	NC	A61	NC	NC
B62	NC	NC	A62	NC	NC
B63	NC	NC	A63	GPIO_TPM_RSTO	J3-68
B64	NC	NC	A64	NC	NC
B65	GND	Ground	A65	GND	Ground
B66	NC	NC	A66	NC	NC
B67	NC	NC	A67	NC	NC

Pin #	Side B		Pin #	Side A	
	Name	Usage		Name	Usage
B68	<b>NC</b>	<b>NC</b>	A68	<b>NC</b>	<b>NC</b>
B69	<b>NC</b>	<b>NC</b>	A69	<b>NC</b>	<b>NC</b>
B70	<b>NC</b>	<b>NC</b>	A70	<b>NC</b>	<b>NC</b>
B71	<b>NC</b>	<b>NC</b>	A71	<b>NC</b>	<b>NC</b>
B72	<b>NC</b>	<b>NC</b>	A72	<b>NC</b>	<b>NC</b>
B73	<b>NC</b>	<b>NC</b>	A73	<b>NC</b>	<b>NC</b>
B74	<b>NC</b>	<b>NC</b>	A74	<b>NC</b>	<b>NC</b>
B75	<b>NC</b>	<b>NC</b>	A75	<b>NC</b>	<b>NC</b>
B76	<b>NC</b>	<b>NC</b>	A76	<b>NC</b>	<b>NC</b>
B77	<b>NC</b>	<b>NC</b>	A77	<b>NC</b>	<b>NC</b>
B78	<b>NC</b>	<b>NC</b>	A78	<b>NC</b>	<b>NC</b>
B79	<b>NC</b>	<b>NC</b>	A79	<b>NC</b>	<b>NC</b>
B80	<b>NC</b>	<b>NC</b>	A80	<b>NC</b>	<b>NC</b>
B81	<b>GND</b>	<b>Ground</b>	A81	<b>GND</b>	<b>Ground</b>
B82	<b>3.3V</b>	<b>3.3V Power</b>	A82	<b>3.3V</b>	<b>3.3V Power</b>





**Стандарт  
Электрон  
Связь**

Мы молодая и активно развивающаяся компания в области поставок электронных компонентов. Мы поставляем электронные компоненты отечественного и импортного производства напрямую от производителей и с крупнейших складов мира.

Благодаря сотрудничеству с мировыми поставщиками мы осуществляем комплексные и плановые поставки широчайшего спектра электронных компонентов.

Собственная эффективная логистика и склад в обеспечивает надежную поставку продукции в точно указанные сроки по всей России.

Мы осуществляем техническую поддержку нашим клиентам и предпродажную проверку качества продукции. На все поставляемые продукты мы предоставляем гарантию .

Осуществляем поставки продукции под контролем ВП МО РФ на предприятия военно-промышленного комплекса России , а также работаем в рамках 275 ФЗ с открытием отдельных счетов в уполномоченном банке. Система менеджмента качества компании соответствует требованиям ГОСТ ISO 9001.

Минимальные сроки поставки, гибкие цены, неограниченный ассортимент и индивидуальный подход к клиентам являются основой для выстраивания долгосрочного и эффективного сотрудничества с предприятиями радиоэлектронной промышленности, предприятиями ВПК и научно-исследовательскими институтами России.

С нами вы становитесь еще успешнее!

**Наши контакты:**

**Телефон:** +7 812 627 14 35

**Электронная почта:** [sales@st-electron.ru](mailto:sales@st-electron.ru)

**Адрес:** 198099, Санкт-Петербург,  
Промышленная ул, дом № 19, литера Н,  
помещение 100-Н Офис 331