

5 V, 16 Kbit (2 Kb x 8) ZEROPOWER[®] SRAM**Features**

- Integrated, ultra low power SRAM and power-fail control circuit
- Unlimited WRITE cycles
- READ cycle time equals WRITE cycle time
- Automatic power-fail chip deselect and WRITE protection
- WRITE protect voltages (V_{PFD} = power-fail deselect voltage):
 - M48Z02: $V_{\text{CC}} = 4.75$ to 5.5 V;
 $4.5 \text{ V} \leq V_{\text{PFD}} \leq 4.75 \text{ V}$
 - M48Z12: $V_{\text{CC}} = 4.5$ to 5.5 V;
 $4.2 \text{ V} \leq V_{\text{PFD}} \leq 4.5 \text{ V}$
- Self-contained battery in the CAPHAT[™] DIP package
- Pin and function compatible with JEDEC standard 2 K x 8 SRAMs
- RoHS compliant
 - Lead-free second level interconnect

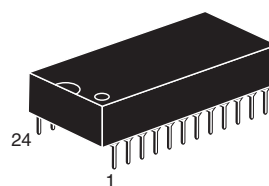

PCDIP24
Battery CAPHAT[™]

Contents

1	Description	5
2	Operation modes	7
2.1	READ mode	7
2.2	WRITE mode	8
2.3	Data retention mode	10
2.4	V _{CC} noise and negative going transients	12
3	Maximum ratings	13
4	DC and AC parameters	14
5	Package mechanical data	17
6	Part numbering	19
7	Environmental information	20
8	Revision history	21

List of tables

Table 1.	Signal names	5
Table 2.	Operating modes	7
Table 3.	READ mode AC characteristics	8
Table 4.	WRITE mode AC characteristics	10
Table 5.	Absolute maximum ratings	13
Table 6.	Operating and AC measurement conditions	14
Table 7.	Capacitance	14
Table 8.	DC characteristics	15
Table 9.	Power down/up AC characteristics	16
Table 10.	Power down/up trip points DC characteristics	16
Table 11.	PCDIP24 – 24-pin plastic DIP, battery CAPHAT™, package mechanical data	17
Table 12.	Ordering information scheme	19
Table 13.	Document revision history	21

List of figures

Figure 1.	Logic diagram	5
Figure 2.	DIP connections	6
Figure 3.	Block diagram	6
Figure 4.	READ mode AC waveforms	8
Figure 5.	WRITE enable controlled, WRITE AC waveform	9
Figure 6.	Chip enable controlled, WRITE AC waveforms	9
Figure 7.	Checking the BOK flag status	11
Figure 8.	Supply voltage protection	12
Figure 9.	AC testing load circuit	14
Figure 10.	Power down/up mode AC waveforms	15
Figure 11.	PCDIP24 – 24-pin plastic DIP, battery CAPHAT™, package outline	17
Figure 12.	Shipping tube dimensions for PCDIP24 package	18
Figure 13.	Recycling symbols	20

1 Description

The M48Z02/12 ZEROPOWER[®] RAM is a 2 K x 8 non-volatile static RAM which is pin and function compatible with the DS1220.

A special 24-pin, 600 mil DIP CAPHAT[™] package houses the M48Z02/12 silicon with a long-life lithium button cell to form a highly integrated battery-backed memory solution.

The M48Z02/12 button cell has sufficient capacity and storage life to maintain data functionality for an accumulated time period of at least 10 years in the absence of power over commercial operating temperature range.

The M48Z02/12 is a non-volatile pin and function equivalent to any JEDEC standard 2 K x 8 SRAM. It also easily fits into many ROM, EPROM, and EEPROM sockets, providing the non-volatility of PROMs without any requirement for special WRITE timing or limitations on the number of WRITES that can be performed.

Figure 1. Logic diagram

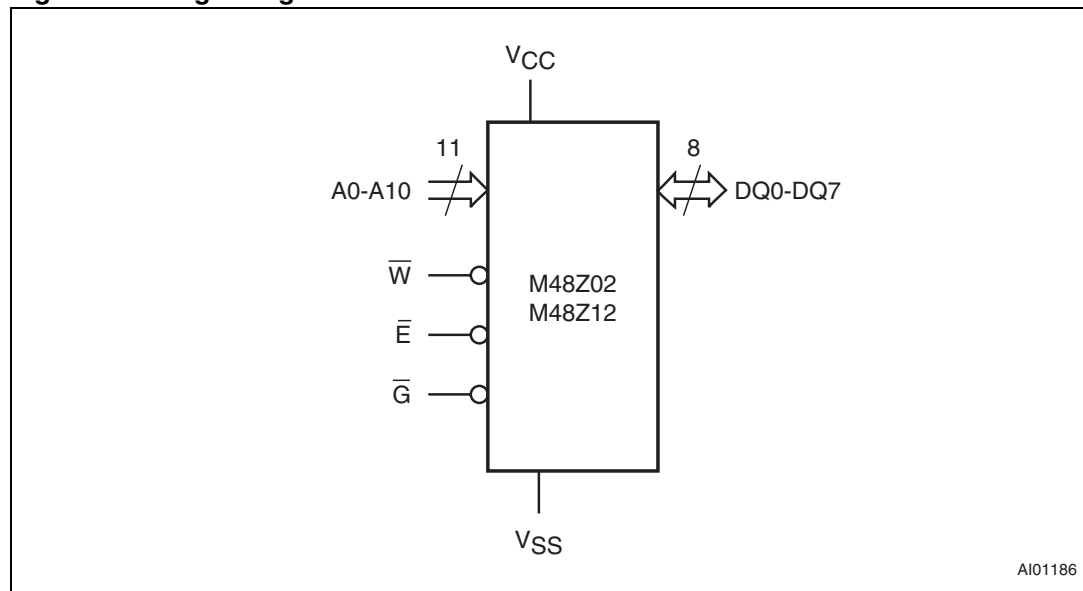

Table 1. Signal names

A0-A10	Address inputs
DQ0-DQ7	Data inputs / outputs
\bar{E}	Chip enable
\bar{G}	Output enable
\bar{W}	WRITE enable
V _{CC}	Supply voltage
V _{SS}	Ground

Figure 2. DIP connections

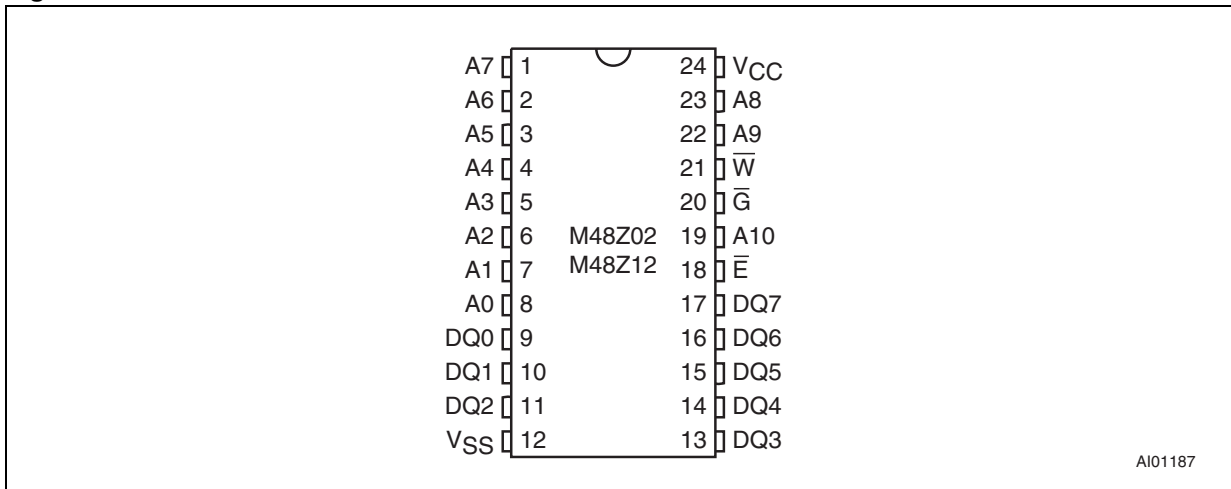
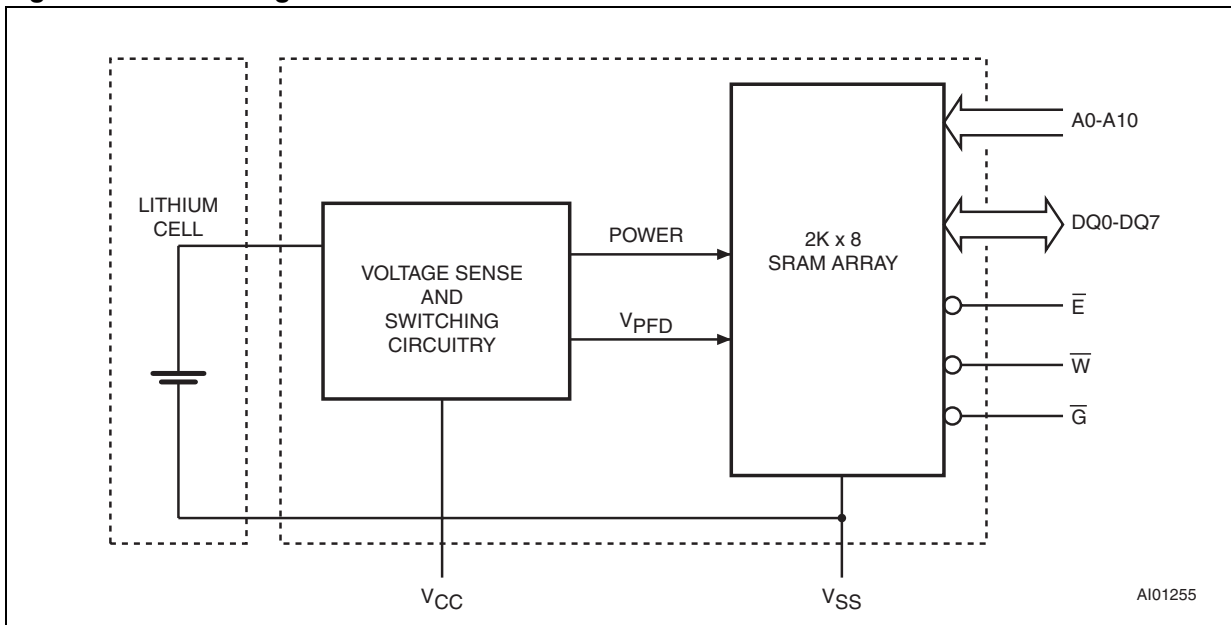

Figure 3. Block diagram



2 Operation modes

The M48Z02/12 also has its own power-fail detect circuit. The control circuitry constantly monitors the single 5 V supply for an out of tolerance condition. When V_{CC} is out of tolerance, the circuit write protects the SRAM, providing a high degree of data security in the midst of unpredictable system operation brought on by low V_{CC} . As V_{CC} falls below approximately 3 V, the control circuitry connects the battery which maintains data operation until valid power returns.

Table 2. Operating modes

Mode	V_{CC}	\bar{E}	\bar{G}	\bar{W}	DQ0-DQ7	Power
Deselect	4.75 to 5.5 V or 4.5 to 5.5 V	V_{IH}	X	X	High Z	Standby
WRITE		V_{IL}	X	V_{IL}	D_{IN}	Active
READ		V_{IL}	V_{IL}	V_{IH}	D_{OUT}	Active
READ		V_{IL}	V_{IH}	V_{IH}	High Z	Active
Deselect	V_{SO} to $V_{PFD}(\min)^{(1)}$	X	X	X	High Z	CMOS standby
Deselect	$\leq V_{SO}^{(1)}$	X	X	X	High Z	Battery backup mode

1. See [Table 10 on page 16](#) for details.

Note: $X = V_{IH}$ or V_{IL} ; V_{SO} = battery backup switchover voltage.

2.1 READ mode

The M48Z02/12 is in the READ mode whenever \bar{W} (WRITE enable) is high and \bar{E} (chip enable) is low. The device architecture allows ripple-through access of data from eight of 16,384 locations in the static storage array. Thus, the unique address specified by the 11 Address Inputs defines which one of the 2,048 bytes of data is to be accessed. Valid data will be available at the data I/O pins within address access time (t_{AVQV}) after the last address input signal is stable, providing that the \bar{E} and \bar{G} access times are also satisfied. If the \bar{E} and \bar{G} access times are not met, valid data will be available after the latter of the chip enable access time (t_{ELQV}) or output enable access time (t_{GLQV}).

The state of the eight three-state data I/O signals is controlled by \bar{E} and \bar{G} . If the outputs are activated before t_{AVQV} , the data lines will be driven to an indeterminate state until t_{AVQV} . If the address inputs are changed while \bar{E} and \bar{G} remain active, output data will remain valid for output data hold time (t_{AXQX}) but will go indeterminate until the next address access.

Figure 4. READ mode AC waveforms

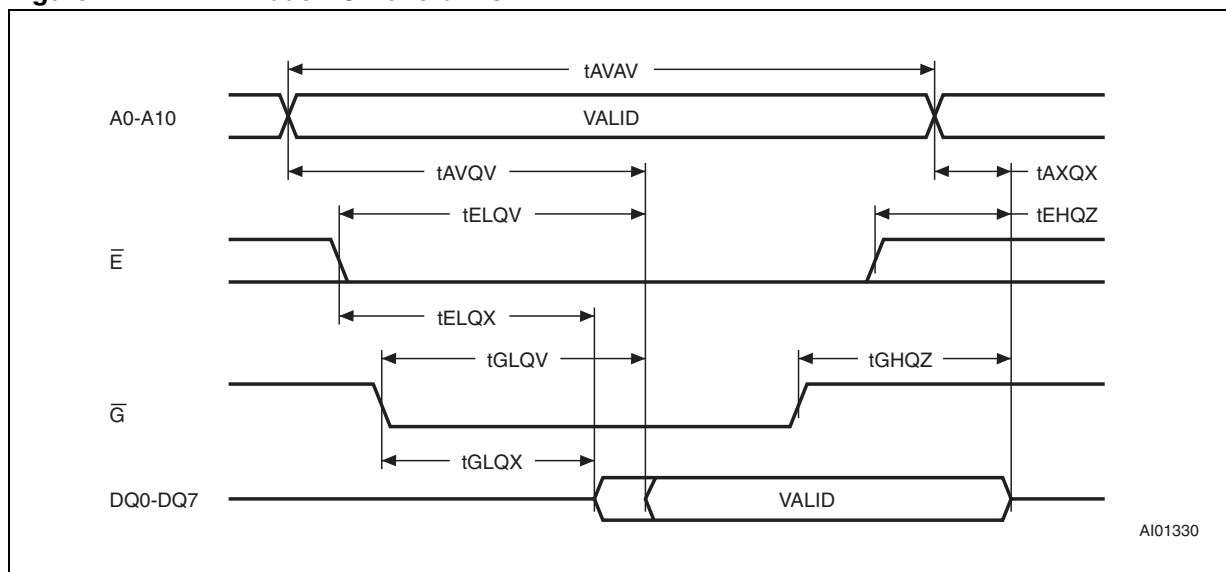

Note: WRITE enable (\bar{W}) = high.

Table 3. READ mode AC characteristics

Symbol	Parameter ⁽¹⁾	M48Z02/M48Z12						Unit
		-70		-150		-200		
		Min	Max	Min	Max	Min	Max	
t_{AVAV}	READ cycle time	70		150		200		ns
t_{AVQV}	Address valid to output valid		70		150		200	ns
t_{ELQV}	Chip enable low to output valid		70		150		200	ns
t_{GLQV}	Output enable low to output valid		35		75		80	ns
t_{ELQX}	Chip enable low to output transition	5		10		10		ns
t_{GLQX}	Output enable low to output transition	5		5		5		ns
t_{EHQZ}	Chip enable high to output Hi-Z		25		35		40	ns
t_{GHQZ}	Output enable high to output Hi-Z		25		35		40	ns
t_{AXQX}	Address transition to output transition	10		5		5		ns

1. Valid for ambient operating temperature: $T_A = 0$ to 70 °C or -40 to 85 °C; $V_{CC} = 4.75$ to 5.5 V or 4.5 to 5.5 V (except where noted).

2.2 WRITE mode

The M48Z02/12 is in the WRITE mode whenever \bar{W} and \bar{E} are active. The start of a WRITE is referenced from the latter occurring falling edge of \bar{W} or \bar{E} . A WRITE is terminated by the earlier rising edge of \bar{W} or \bar{E} . The addresses must be held valid throughout the cycle. \bar{E} or \bar{W} must return high for a minimum of t_{EHAX} from chip enable or t_{WHAX} from WRITE enable prior to the initiation of another READ or WRITE cycle. Data-in must be valid t_{DVWH} prior to the end of WRITE and remain valid for t_{WHDX} afterward. \bar{G} should be kept high during WRITE cycles to avoid bus contention; although, if the output bus has been activated by a low on \bar{E} and \bar{G} , a low on \bar{W} will disable the outputs t_{WLQZ} after \bar{W} falls.

Figure 5. WRITE enable controlled, WRITE AC waveform

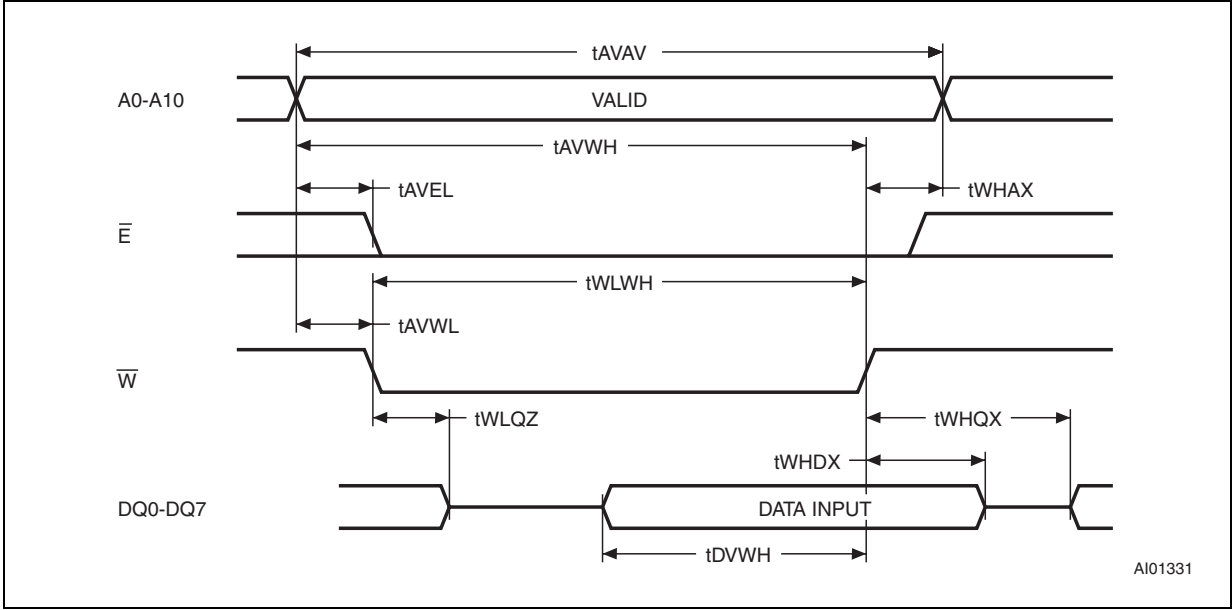

Figure 6. Chip enable controlled, WRITE AC waveforms

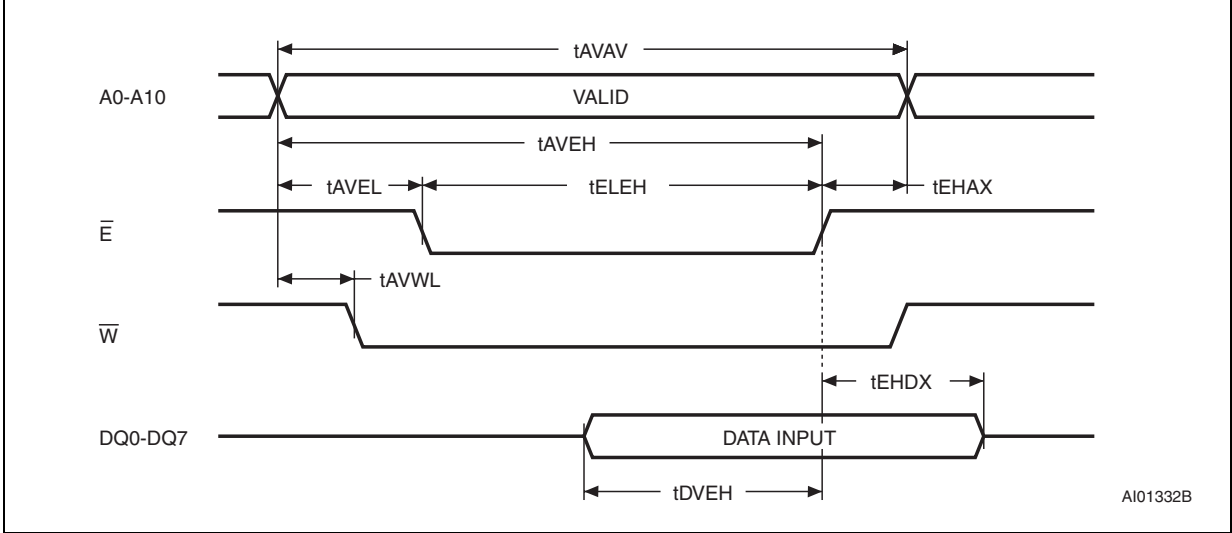

Table 4. WRITE mode AC characteristics

Symbol	Parameter ⁽¹⁾	M48Z02/M48Z12						Unit
		-70		-150		-200		
		Min	Max	Min	Max	Min	Max	
t _{AVAV}	WRITE cycle time	70		150		200		ns
t _{AVWL}	Address valid to WRITE enable low	0		0		0		ns
t _{AVEL}	Address valid to chip enable 1 low	0		0		0		ns
t _{WLWH}	WRITE enable pulse width	50		90		120		ns
t _{ELEH}	Chip enable low to chip enable 1 high	55		90		120		ns
t _{WHAX}	WRITE enable high to address transition	0		10		10		ns
t _{EHAX}	Chip enable high to address transition	0		10		10		ns
t _{DVWH}	Input valid to WRITE enable high	30		40		60		ns
t _{DVEH}	Input valid to chip enable high	30		40		60		ns
t _{WHDX}	WRITE enable high to input transition	5		5		5		ns
t _{EHDX}	Chip enable high to input transition	5		5		5		ns
t _{WLQZ}	WRITE enable low to output Hi-Z		25		50		60	ns
t _{AVWH}	Address valid to WRITE enable high	60		120		140		ns
t _{AVEH}	Address valid to chip enable high	60		120		140		ns
t _{WHQX}	WRITE enable high to output transition	5		10		10		ns

1. Valid for ambient operating temperature: T_A = 0 to 70 °C or -40 to 85 °C; V_{CC} = 4.75 to 5.5 V or 4.5 to 5.5 V (except where noted).

2.3 Data retention mode

With valid V_{CC} applied, the M48Z02/12 operates as a conventional BYTEWIDE™ static RAM. Should the supply voltage decay, the RAM will automatically power-fail deselect, write protecting itself when V_{CC} falls within the V_{PFD} (max), V_{PFD} (min) window. All outputs become high impedance, and all inputs are treated as “don't care.”

Note: A power failure during a WRITE cycle may corrupt data at the currently addressed location, but does not jeopardize the rest of the RAM's content. At voltages below V_{PFD} (min), the user can be assured the memory will be in a write protected state, provided the V_{CC} fall time is not less than t_F. The M48Z02/12 may respond to transient noise spikes on V_{CC} that reach into the deselect window during the time the device is sampling V_{CC}. Therefore, decoupling of the power supply lines is recommended.

The power switching circuit connects external V_{CC} to the RAM and disconnects the battery when V_{CC} rises above V_{SO}. As V_{CC} rises, the battery voltage is checked. If the voltage is too low, an internal Battery Not OK (BOK) flag will be set. The BOK flag can be checked after power up. If the BOK flag is set, the first WRITE attempted will be blocked. The flag is automatically cleared after the first WRITE, and normal RAM operation resumes. [Figure 7 on page 11](#) illustrates how a BOK check routine could be structured.

For more information on a battery storage life refer to the application note AN1012.

Figure 7. Checking the $\overline{\text{BOK}}$ flag status

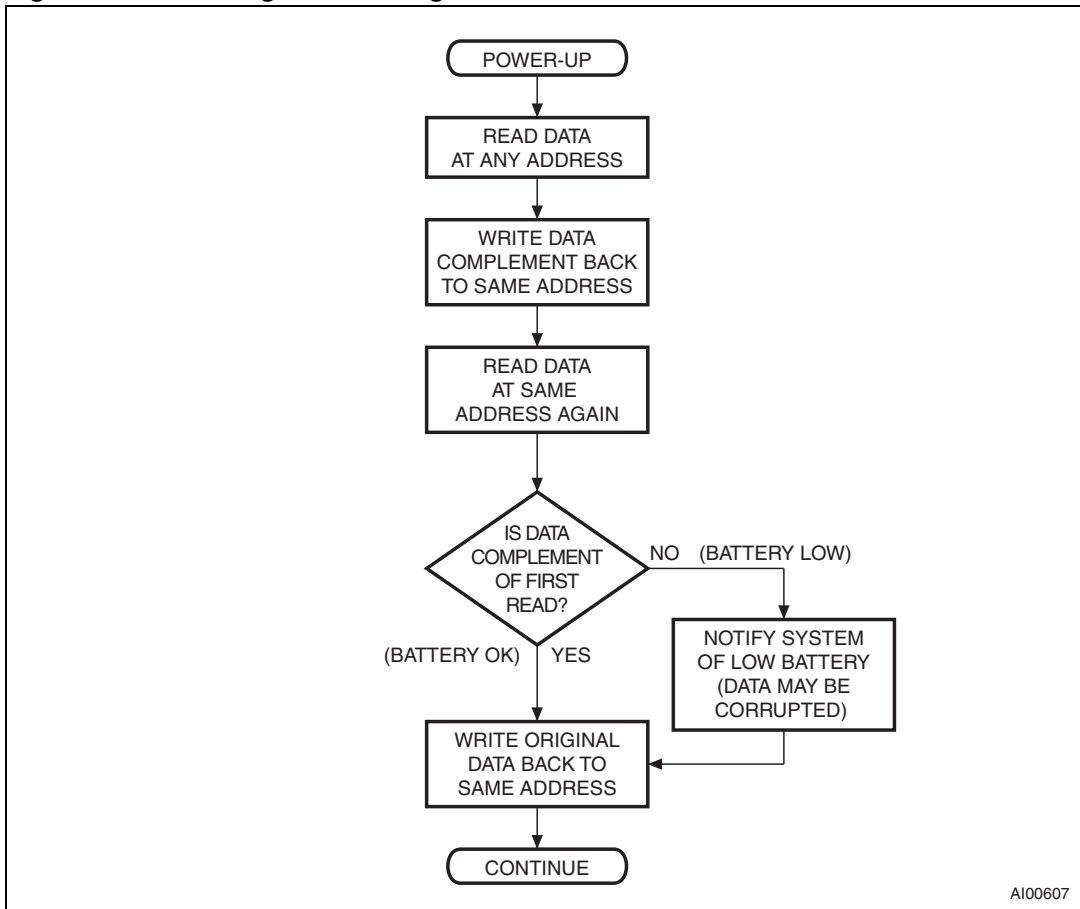

2.4 V_{CC} noise and negative going transients

I_{CC} transients, including those produced by output switching, can produce voltage fluctuations, resulting in spikes on the V_{CC} bus. These transients can be reduced if capacitors are used to store energy which stabilizes the V_{CC} bus. The energy stored in the bypass capacitors will be released as low going spikes are generated or energy will be absorbed when overshoots occur. A ceramic bypass capacitor value of 0.1 μF (as shown in [Figure 8](#)) is recommended in order to provide the needed filtering.

In addition to transients that are caused by normal SRAM operation, power cycling can generate negative voltage spikes on V_{CC} that drive it to values below V_{SS} by as much as one volt. These negative spikes can cause data corruption in the SRAM while in battery backup mode. To protect from these voltage spikes, STMicroelectronics recommends connecting a Schottky diode from V_{CC} to V_{SS} (cathode connected to V_{CC}, anode to V_{SS}). Schottky diode 1N5817 is recommended for through hole and MBR120T3 is recommended for surface mount.

Figure 8. Supply voltage protection

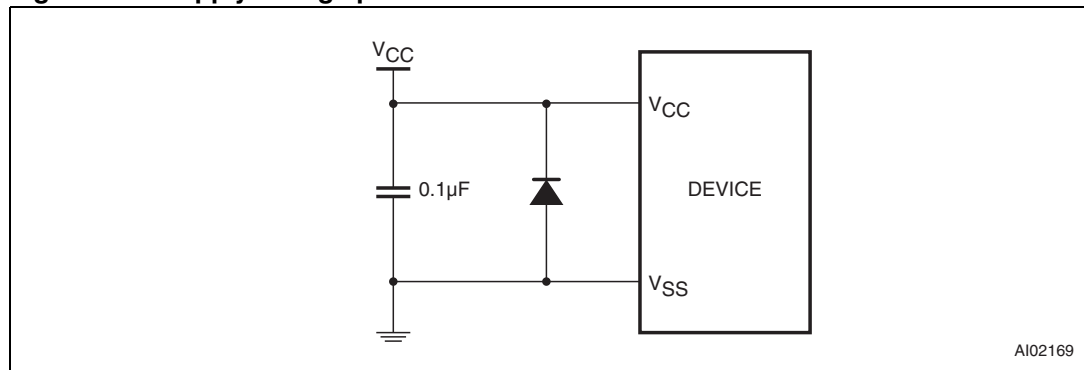

3 Maximum ratings

Stressing the device above the rating listed in the absolute maximum ratings table may cause permanent damage to the device. These are stress ratings only and operation of the device at these or any other conditions above those indicated in the operating sections of this specification is not implied. Exposure to absolute maximum rating conditions for extended periods may affect device reliability.

Table 5. Absolute maximum ratings

Symbol	Parameter		Value	Unit
T_A	Ambient operating temperature	Grade 1	0 to 70	°C
T_{STG}	Storage temperature (V_{CC} off, oscillator off)		-40 to 85	°C
$T_{SLD}^{(1)}$	Lead solder temperature for 10 seconds		260	°C
V_{IO}	Input or output voltages		-0.3 to 7	V
V_{CC}	Supply voltage		-0.3 to 7	V
I_O	Output current		20	mA
P_D	Power dissipation		1	W

1. Soldering temperature of the IC leads is to not exceed 260 °C for 10 seconds. Furthermore, the devices shall not be exposed to IR reflow nor preheat cycles (as performed as part of wave soldering). ST recommends the devices be hand-soldered or placed in sockets to avoid heat damage to the batteries.

Caution: *Negative undershoots below -0.3 V are not allowed on any pin while in the battery backup mode.*

4 DC and AC parameters

This section summarizes the operating and measurement conditions, as well as the DC and AC characteristics of the device. The parameters in the following DC and AC characteristic tables are derived from tests performed under the measurement conditions listed in [Table 6: Operating and AC measurement conditions](#). Designers should check that the operating conditions in their projects match the measurement conditions when using the quoted parameters.

Table 6. Operating and AC measurement conditions

Parameter		M48Z02	M48Z12	Unit
Supply voltage (V _{CC})		4.75 to 5.5	4.5 to 5.5	V
Ambient operating temperature (T _A)	Grade 1	0 to 70	0 to 70	°C
Load capacitance (C _L)		100	100	pF
Input rise and fall times		≤ 5	≤ 5	ns
Input pulse voltages		0 to 3	0 to 3	V
Input and output timing ref. voltages		1.5	1.5	V

Note: Output Hi-Z is defined as the point where data is no longer driven.

Figure 9. AC testing load circuit

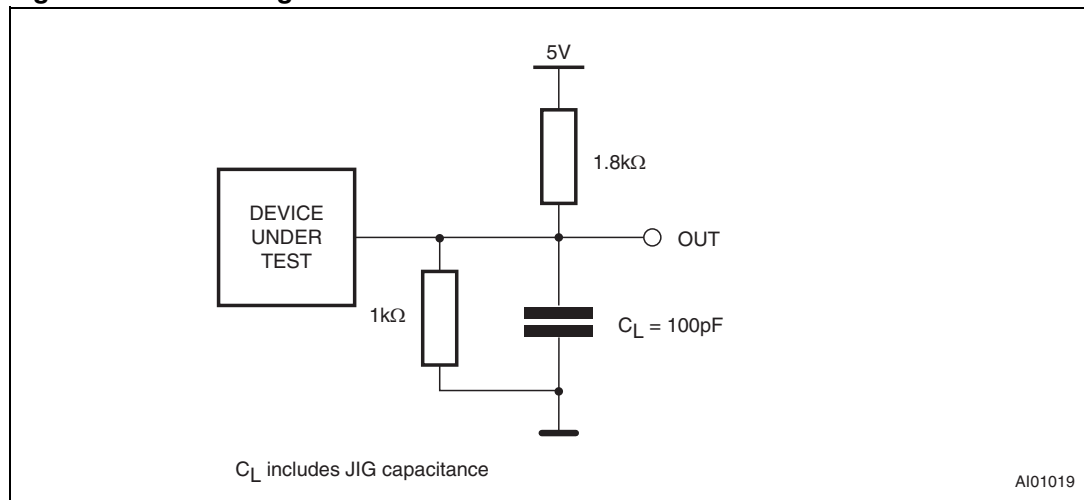

Table 7. Capacitance

Symbol	Parameter ⁽¹⁾⁽²⁾	Min	Max	Unit
C _{IN}	Input capacitance	-	10	pF
C _{IO} ⁽³⁾	Input / output capacitance	-	10	pF

1. Effective capacitance measured with power supply at 5 V. Sampled only, not 100% tested.
2. At 25°C, f = 1 MHz.
3. Outputs deselected.

Table 8. DC characteristics

Symbol	Parameter	Test condition ⁽¹⁾	Min	Max	Unit
I_{LI}	Input leakage current	$0V \leq V_{IN} \leq V_{CC}$		± 1	μA
$I_{LO}^{(2)}$	Output leakage current	$0V \leq V_{OUT} \leq V_{CC}$		± 1	μA
I_{CC}	Supply current	Outputs open		80	mA
I_{CC1}	Supply current (standby) TTL	$\bar{E} = V_{IH}$		3	mA
I_{CC2}	Supply current (standby) CMOS	$\bar{E} = V_{CC} - 0.2 V$		3	mA
V_{IL}	Input low voltage		-0.3	0.8	V
V_{IH}	Input high voltage		2.2	$V_{CC} + 0.3$	V
V_{OL}	Output low voltage	$I_{OL} = 2.1 mA$		0.4	V
V_{OH}	Output high voltage	$I_{OH} = -1 mA$	2.4		V

- Valid for ambient operating temperature: $T_A = 0$ to $70^\circ C$; $V_{CC} = 4.75$ to $5.5 V$ or 4.5 to $5.5 V$ (except where noted).
- Outputs deselected.

Figure 10. Power down/up mode AC waveforms

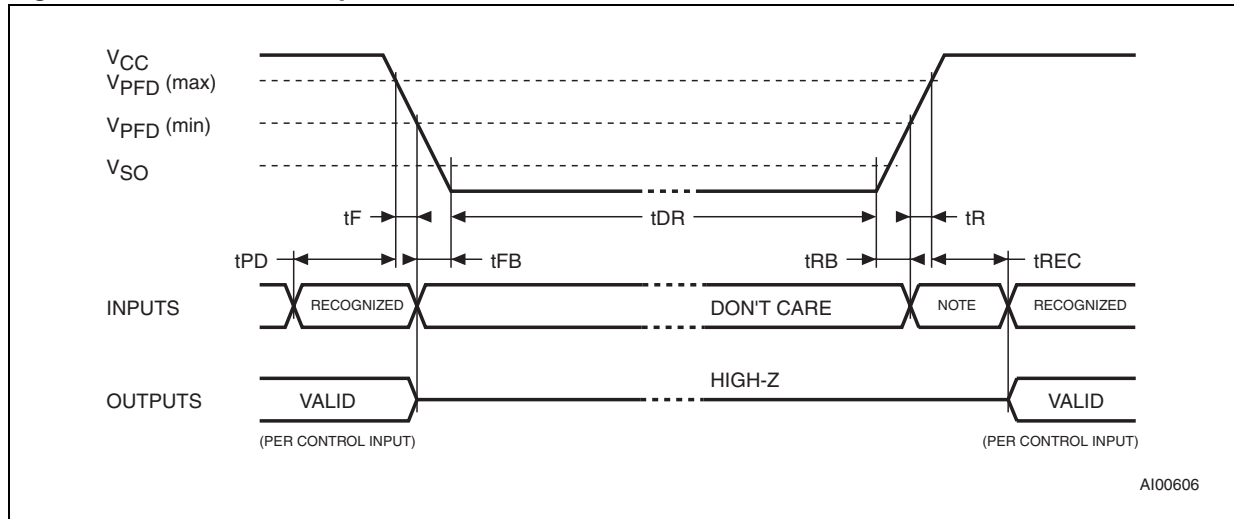

Note: *Inputs may or may not be recognized at this time. Caution should be taken to keep \bar{E} high as V_{CC} rises past $V_{PFD} (min)$. Some systems may perform inadvertent WRITE cycles after V_{CC} rises above $V_{PFD} (min)$ but before normal system operations begin. Even though a power on reset is being applied to the processor, a reset condition may not occur until after the system is running.*

Table 9. Power down/up AC characteristics

Symbol	Parameter ⁽¹⁾	Min	Max	Unit
t_{PD}	\overline{E} or \overline{W} at V_{IH} before power down	0	-	μs
$t_F^{(2)}$	V_{PFD} (max) to V_{PFD} (min) V_{CC} fall time	300	-	μs
$t_{FB}^{(3)}$	V_{PFD} (min) to V_{SS} V_{CC} fall time	10	-	μs
t_R	V_{PFD} (min) to V_{PFD} (max) V_{CC} rise time	0	-	μs
t_{RB}	V_{SS} to V_{PFD} (min) V_{CC} rise time	1	-	μs
t_{REC}	\overline{E} or \overline{W} at V_{IH} after power up	2	-	ms

- Valid for ambient operating temperature: $T_A = 0$ to 70 °C; $V_{CC} = 4.75$ to 5.5 V or 4.5 to 5.5 V (except where noted).
- V_{PFD} (max) to V_{PFD} (min) fall time of less than t_F may result in deselection/write protection not occurring until $200 \mu s$ after V_{CC} passes V_{PFD} (min).
- V_{PFD} (min) to V_{SS} fall time of less than t_{FB} may cause corruption of RAM data.

Table 10. Power down/up trip points DC characteristics

Symbol	Parameter ⁽¹⁾⁽²⁾	Min	Typ	Max	Unit	
V_{PFD}	Power-fail deselect voltage	M48Z02	4.5	4.6	4.75	V
		M48Z12	4.2	4.3	4.5	V
V_{SO}	Battery backup switchover voltage		3.0		V	
$t_{DR}^{(3)}$	Expected data retention time	10			YEARS	

- All voltages referenced to V_{SS} .
- Valid for ambient operating temperature: $T_A = 0$ to 70 °C; $V_{CC} = 4.75$ to 5.5 V or 4.5 to 5.5 V (except where noted).
- At 25 °C, $V_{CC} = 0$ V.

5 Package mechanical data

In order to meet environmental requirements, ST offers these devices in different grades of ECOPACK[®] packages, depending on their level of environmental compliance. ECOPACK[®] specifications, grade definitions and product status are available at: www.st.com. ECOPACK[®] is an ST trademark.

Figure 11. PCDIP24 – 24-pin plastic DIP, battery CAPHAT[™], package outline

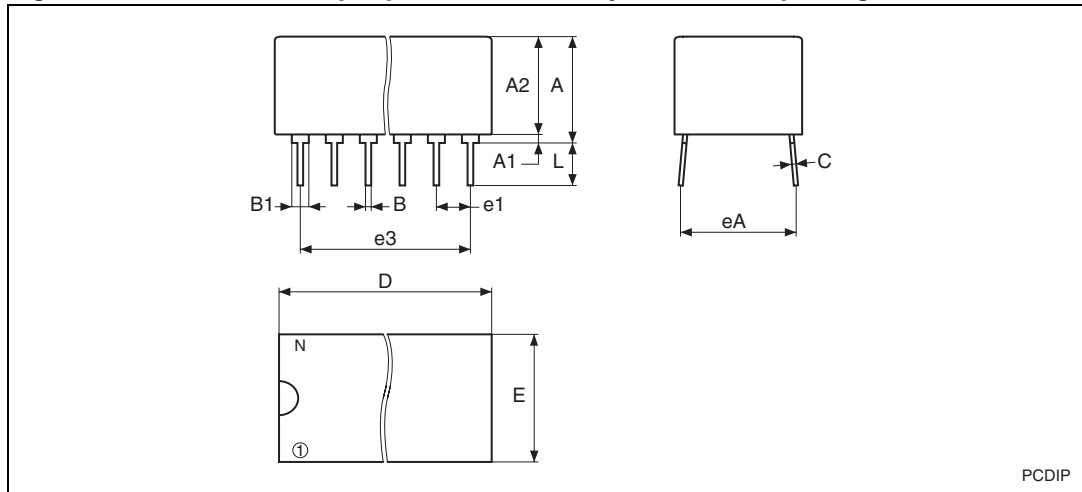

Note: Drawing is not to scale.

Table 11. PCDIP24 – 24-pin plastic DIP, battery CAPHAT[™], package mechanical data

Symb	mm			inches		
	Typ	Min	Max	Typ	Min	Max
A		8.89	9.65		0.350	0.380
A1		0.38	0.76		0.015	0.030
A2		8.38	8.89		0.330	0.350
B		0.38	0.53		0.015	0.021
B1		1.14	1.78		0.045	0.070
C		0.20	0.31		0.008	0.012
D		34.29	34.80		1.350	1.370
E		17.83	18.34		0.702	0.722
e1		2.29	2.79		0.090	0.110
e3	27.94			1.1		
eA		15.24	16.00		0.600	0.630
L		3.05	3.81		0.120	0.150
N		24			24	

Figure 12. Shipping tube dimensions for PCDIP24 package

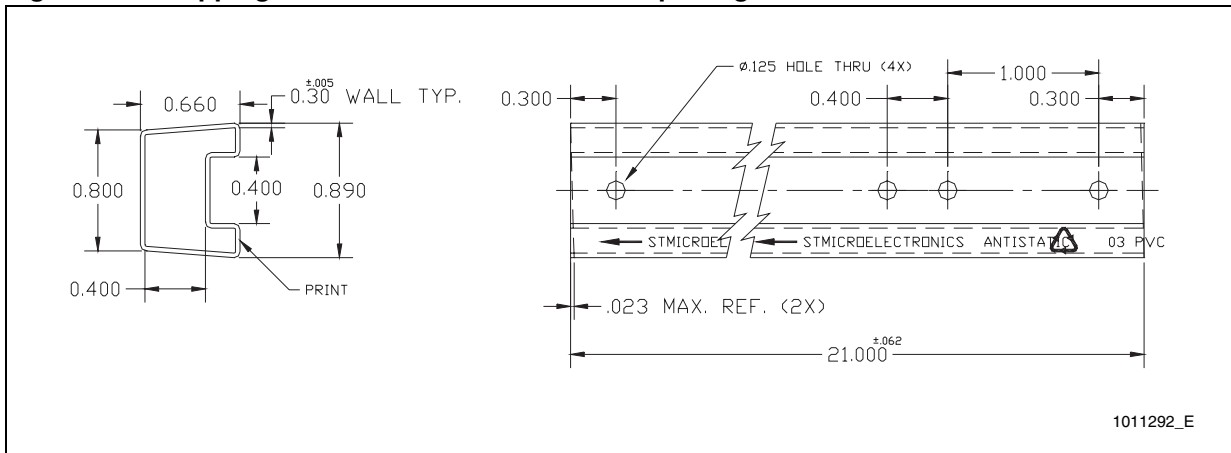

Note: All dimensions are in inches.

6 Part numbering

Table 12. Ordering information scheme

Example:	M48Z	02	-70	PC	1
Device type					
M48Z					
Supply voltage and write protect voltage					
02 = $V_{CC} = 4.75$ to 5.5 V; $V_{PFD} = 4.5$ to 4.75 V					
12 = $V_{CC} = 4.5$ to 5.5 V; $V_{PFD} = 4.2$ to 4.5 V					
Speed					
-70 = 70 ns (M48Z02/12)					
-150 = 150 ns (M48Z02/12)					
-200 = 200 ns (M48Z02/12) ⁽¹⁾					
Package					
PC = PCDIP24					
Temperature range					
1 = 0 to 70 °C					

1. Not recommended for new design. Contact local ST sales office for availability.

For a list of available options (e.g., speed, package) or for further information on any aspect of this device, please contact the ST sales office nearest you.

7 Environmental information

Figure 13. Recycling symbols



This product contains a non-rechargeable lithium (lithium carbon monofluoride chemistry) button cell battery fully encapsulated in the final product.

Recycle or dispose of batteries in accordance with the battery manufacturer's instructions and local/national disposal and recycling regulations.

8 Revision history

Table 13. Document revision history

Date	Revision	Changes
May-1999	1	First issue
09-Jul-2001	2	Reformatted; temperature information added to tables (Table 5 , 6 , 7 , 8 , 3 , 4 , 9 , 10); Figure updated (Figure 10)
17-Dec-2001	2.1	Remove references to “clock” in document
20-May-2002	2.2	Updated V _{CC} noise and negative going transients text
01-Apr-2003	3	v2.2 template applied; test condition updated (Table 10)
22-Apr-2003	3.1	Fix error in ordering information (Table 12)
12-Dec-2005	4	Update template, Lead-free text, and remove references to ‘crystal’ and footnote (Table 8 , 12)
02-Nov-2007	5	Reformatted document; added lead-free second level interconnect information to cover page and Section 5: Package mechanical data ; updated Table 5 , 6 , 8 , 9 , 10 , 12 .
03-Dec-2008	6	Added Section 7: Environmental information ; minor formatting changes.
27-May-2010	7	Updated Section 3 , Table 11 , text in Section 5 ; reformatted document.
21-Jan-2011	8	Updated Table 12: Ordering information scheme for 200 ns version of devices; updated Section 7 ; added Figure 12 ; minor textual updates.
07-Jun-2011	9	Updated footnote of Table 5: Absolute maximum ratings .

Please Read Carefully:

Information in this document is provided solely in connection with ST products. STMicroelectronics NV and its subsidiaries ("ST") reserve the right to make changes, corrections, modifications or improvements, to this document, and the products and services described herein at any time, without notice.

All ST products are sold pursuant to ST's terms and conditions of sale.

Purchasers are solely responsible for the choice, selection and use of the ST products and services described herein, and ST assumes no liability whatsoever relating to the choice, selection or use of the ST products and services described herein.

No license, express or implied, by estoppel or otherwise, to any intellectual property rights is granted under this document. If any part of this document refers to any third party products or services it shall not be deemed a license grant by ST for the use of such third party products or services, or any intellectual property contained therein or considered as a warranty covering the use in any manner whatsoever of such third party products or services or any intellectual property contained therein.

UNLESS OTHERWISE SET FORTH IN ST'S TERMS AND CONDITIONS OF SALE ST DISCLAIMS ANY EXPRESS OR IMPLIED WARRANTY WITH RESPECT TO THE USE AND/OR SALE OF ST PRODUCTS INCLUDING WITHOUT LIMITATION IMPLIED WARRANTIES OF MERCHANTABILITY, FITNESS FOR A PARTICULAR PURPOSE (AND THEIR EQUIVALENTS UNDER THE LAWS OF ANY JURISDICTION), OR INFRINGEMENT OF ANY PATENT, COPYRIGHT OR OTHER INTELLECTUAL PROPERTY RIGHT.

UNLESS EXPRESSLY APPROVED IN WRITING BY AN AUTHORIZED ST REPRESENTATIVE, ST PRODUCTS ARE NOT RECOMMENDED, AUTHORIZED OR WARRANTED FOR USE IN MILITARY, AIR CRAFT, SPACE, LIFE SAVING, OR LIFE SUSTAINING APPLICATIONS, NOR IN PRODUCTS OR SYSTEMS WHERE FAILURE OR MALFUNCTION MAY RESULT IN PERSONAL INJURY, DEATH, OR SEVERE PROPERTY OR ENVIRONMENTAL DAMAGE. ST PRODUCTS WHICH ARE NOT SPECIFIED AS "AUTOMOTIVE GRADE" MAY ONLY BE USED IN AUTOMOTIVE APPLICATIONS AT USER'S OWN RISK.

Resale of ST products with provisions different from the statements and/or technical features set forth in this document shall immediately void any warranty granted by ST for the ST product or service described herein and shall not create or extend in any manner whatsoever, any liability of ST.

ST and the ST logo are trademarks or registered trademarks of ST in various countries.

Information in this document supersedes and replaces all information previously supplied.

The ST logo is a registered trademark of STMicroelectronics. All other names are the property of their respective owners.

© 2011 STMicroelectronics - All rights reserved

STMicroelectronics group of companies

Australia - Belgium - Brazil - Canada - China - Czech Republic - Finland - France - Germany - Hong Kong - India - Israel - Italy - Japan - Malaysia - Malta - Morocco - Philippines - Singapore - Spain - Sweden - Switzerland - United Kingdom - United States of America

www.st.com



**Стандарт
Электрон
Связь**

Мы молодая и активно развивающаяся компания в области поставок электронных компонентов. Мы поставляем электронные компоненты отечественного и импортного производства напрямую от производителей и с крупнейших складов мира.

Благодаря сотрудничеству с мировыми поставщиками мы осуществляем комплексные и плановые поставки широчайшего спектра электронных компонентов.

Собственная эффективная логистика и склад в обеспечивает надежную поставку продукции в точно указанные сроки по всей России.

Мы осуществляем техническую поддержку нашим клиентам и предпродажную проверку качества продукции. На все поставляемые продукты мы предоставляем гарантию .

Осуществляем поставки продукции под контролем ВП МО РФ на предприятия военно-промышленного комплекса России , а также работаем в рамках 275 ФЗ с открытием отдельных счетов в уполномоченном банке. Система менеджмента качества компании соответствует требованиям ГОСТ ISO 9001.

Минимальные сроки поставки, гибкие цены, неограниченный ассортимент и индивидуальный подход к клиентам являются основой для выстраивания долгосрочного и эффективного сотрудничества с предприятиями радиоэлектронной промышленности, предприятиями ВПК и научно-исследовательскими институтами России.

С нами вы становитесь еще успешнее!

Наши контакты:

Телефон: +7 812 627 14 35

Электронная почта: sales@st-electron.ru

Адрес: 198099, Санкт-Петербург,
Промышленная ул, дом № 19, литера Н,
помещение 100-Н Офис 331