



QorIQ® LS1 Processor Family

QorIQ LS1043A Reference Design Board

The QorIQ LS1043A processor is NXP's first quad-core, 64-bit ARM®-based processor for embedded networking and industrial infrastructure.

PROCESSOR OVERVIEW

Both the dual-core version (LS1023A) and quad-core version (LS1043A) deliver greater than 10 Gbit/s of performance, flexible I/O and support for fanless, small-form-factor designs with BOM optimizations for economic low-layer PCB, lower cost power supply and single clock design such as integrated service branch routers, SDN and NFV edge platforms, industry 4.0 gateways, industrial PLC and control and security appliances.

The QorIQ LS1043A processor takes ARM processing performance to the next level with up to four 64-bit cores operating at 1.6 GHz and a large 1 MB L2 cache for the best CPU performance per watt in a processor that runs on voltage as low as five watts. This powerful CPU complex is coupled with the proven offload engines of the QorIQ data path acceleration architecture (DPAA) to deliver up to 10 Gbit/s performance and protocol processing with minimal CPU overhead.

REFERENCE DESIGN BOARD

The QorIQ LS1043A reference design board (LS1043A-RDB) and NXP software development kit (SDK) can help shorten your time-to-market. The board, which exercises most

capabilities of the device, serves as a reference for your hardware development. It can also be used as a debug tool to check behaviors on the board compared to behaviors seen on prototype boards.

The LS1043A-RDB supports one PCI Express® slot, one mini-PCI Express connector, an SD/MMC connector interface and three USB 3.0 receptacles. These components, integrated with the QorIQ LS1043A processor, provide an applicationspecific platform that can help you get a jump start on your next design. The LS1043A-RDB also supports 2 GB of DDR4 at 1600 MHz, 128 MB of NOR flash and 512 MB NAND flash.

In addition, the LS1043A-RDB is loaded with the Embedded Linux® software development kit (SDK) for QorIQ processors v1.8. The SDK includes a 64-bit SMP Linux kernel, user space DPAA for high-performance packet handling, U-boot, the GCC tool chain and virtualization support and many other features.



BOARD HARDWARE FEATURES

Processor

- ▶ QorIQ LS1043A quad-core processor based on ARM Cortex®-A53 at 1.6 GHz
- ▶ Supports single-ended clock input for generating various device frequencies

Memory

- ▶ Supports 2 GB DDR4 SDRAM discrete devices
- ▶ 32-bit DDR4 bus
- ▶ Supports data rates of up to 1600 MT/s
- ▶ 128 MB NOR flash, 16-bit
- ▶ 512 MB SLC NAND flash with ECC support
- ▶ SDHC port connects directly to a full SD/MMC slot
- ▶ 16 MB high-speed flash memory (up to 108 MHz in the single-transfer rate mode)

PCI Express

- ▶ One PCIe slot
- ▶ One mini-PCIe connector

USB

- ▶ Two super-speed USB 3.0 type A ports
- ▶ Supports one USB 2.0 connection on the mini-PCIe connector

Ethernet

- ▶ RJ45 connector for Ethernet 10 GB support
- ▶ Four (4) RJ45 connectors for QSGMII support

UART

- ▶ One RJ45 to DB9 connector with two UART ports
- ▶ UART1 is routed to CMSISDAP circuit and supports USB port to access serial port as console

Other

- ▶ JTAG/COP for debug
- ▶ Thermal monitor

QorIQ LS1043A-RDB BLOCK DIAGRAM

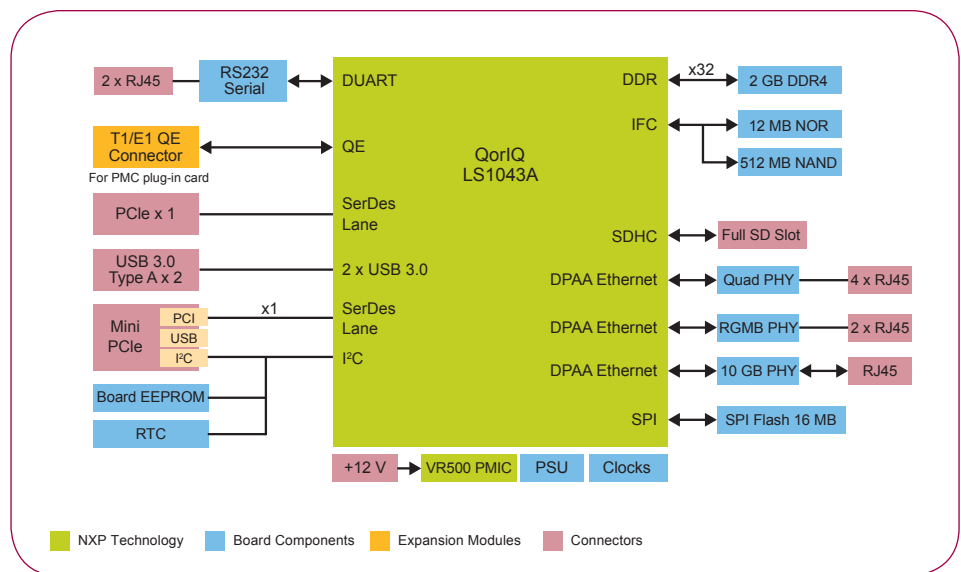

QorIQ LS1043A-RDB BOARD

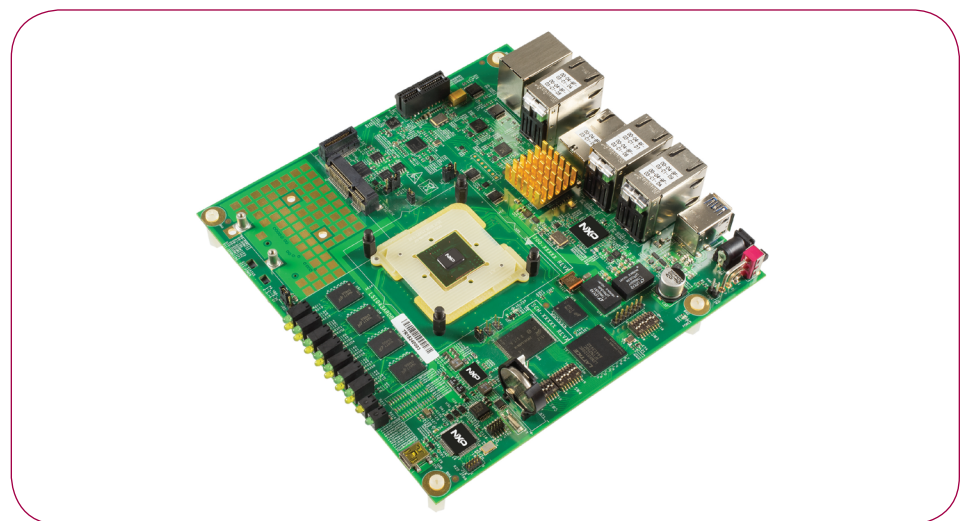

COMPLETE ENABLEMENT, RICH ECOSYSTEM

NXP's strong legacy of networking expertise and ARM's rapidly growing development base provides a rich ecosystem for our customers. Our extensive third-party ecosystem, the largest and most established in the communications market, supports all QorIQ LS series devices. This environment also supports the vibrant, growing ARM ecosystem, including

the Linaro™ not-for-profit engineering organization and the exciting OpenData Plane™ project, a project that strives to deliver open-source, cross-platform interoperability.

In conjunction with our expertise and worldwide support infrastructure, this broad ecosystem helps customers accelerate their migration from non-NXP solutions and legacy NXP devices, preserve investment costs and reduce time-to-market.



Стандарт Электрон Связь

Мы молодая и активно развивающаяся компания в области поставок электронных компонентов. Мы поставляем электронные компоненты отечественного и импортного производства напрямую от производителей и с крупнейших складов мира.

Благодаря сотрудничеству с мировыми поставщиками мы осуществляем комплексные и плановые поставки широчайшего спектра электронных компонентов.

Собственная эффективная логистика и склад в обеспечивает надежную поставку продукции в точно указанные сроки по всей России.

Мы осуществляем техническую поддержку нашим клиентам и предпродажную проверку качества продукции. На все поставляемые продукты мы предоставляем гарантию .

Осуществляем поставки продукции под контролем ВП МО РФ на предприятия военно-промышленного комплекса России , а также работаем в рамках 275 ФЗ с открытием отдельных счетов в уполномоченном банке. Система менеджмента качества компании соответствует требованиям ГОСТ ISO 9001.

Минимальные сроки поставки, гибкие цены, неограниченный ассортимент и индивидуальный подход к клиентам являются основой для выстраивания долгосрочного и эффективного сотрудничества с предприятиями радиоэлектронной промышленности, предприятиями ВПК и научно-исследовательскими институтами России.

С нами вы становитесь еще успешнее!

Наши контакты:

Телефон: +7 812 627 14 35

Электронная почта: sales@st-electron.ru

Адрес: 198099, Санкт-Петербург,
Промышленная ул, дом № 19, литера Н,
помещение 100-Н Офис 331