

SPEC

| | |
|----------|-----------------------|
| Spec No. | TQ3C-8EAF0-E1TAB02-00 |
| Date | January 21, 2014 |

TYPE : T-55786GD084J-LW-AHN (TCG084SVLQ*PNN-AN*33)

< 8.4 inch SVGA transmissive color TFT

with LED backlight and constant current circuit for LED backlight>

CONTENTS

1. Application
2. Construction and outline
3. Mechanical specifications
4. Absolute maximum ratings
5. Electrical characteristics
6. Optical characteristics
7. Interface signals
8. Input timing characteristics
9. Lot number identification
10. Warranty
11. Precautions for use
12. Reliability test data
13. Outline drawing



KYOCERA DISPLAY CORPORATION

This specification is subject to change without notice.
Consult Kyocera display before ordering.

| Original Issue Date | Designed by: Engineering dept. | | | Confirmed by: QA dept. | |
|---------------------|--------------------------------|-----------|-------------|------------------------|-----------|
| | Prepared | Checked | Approved | Checked | Approved |
| January 21, 2014 | T. Andera | S. Ohtaka | M. Fujitani | O. Sato | I. Hamano |

| | | |
|-----------------------------------|--|-----------|
| Spec No. TQ3C-8EAF0-E1TAB02-00 | Part No. T-55786GD084J-LW-AHN (TCG084SVLQ*PNN-AN*33) | Page - |
|-----------------------------------|--|-----------|

Warning

1. This Kyocera LCD module has been specifically designed for use only in electronic devices and industrial machines in the area of audio control, office automation, industrial control, home appliances, etc. The module should not be used in applications where the highest level of safety and reliability are required and module failure or malfunction of such module results in physical harm or loss of life, as well as enormous damage or loss. Such fields of applications include, without limitation, medical, aerospace, communications infrastructure, atomic energy control. Kyocera expressly disclaims any and all liability resulting in any way to the use of the module in such applications.

2. Customer agrees to indemnify, defend and hold Kyocera harmless from and against any and all actions, claims, damages, liabilities, awards, costs, and expenses, including legal expenses, resulting from or arising out of Customer's use, or sale for use, or Kyocera modules in applications.

Caution

1. Kyocera shall have the right, which Customer hereby acknowledges, to immediately scrap or destroy tooling for Kyocera modules for which no Purchase Orders have been received from the Customer in a two-year period.

| | | |
|-----------------------------------|--|-----------|
| Spec No. TQ3C-8EAF0-E1TAB02-00 | Part No. T-55786GD084J-LW-AHN (TCG084SVLQ*PNN-AN*33) | Page - |
|-----------------------------------|--|-----------|

Revision record

| Date | | Designed by : Engineering dept. | | | Confirmed by : QA dept. | |
|---------|------|---------------------------------|--------------|----------|-------------------------|----------|
| | | Prepared | Checked | Approved | Checked | Approved |
| | | | | | | |
| Rev.No. | Date | Page | Descriptions | | | |
| | | | | | | |

1. Application

This document defines the specification of T-55786GD084J-LW-AHN. (TCG084SVLQ*PNN-AN*33)
(RoHS Compliant)

2. Construction and outline

| | |
|--------------------|--|
| LCD | : Transmissive color dot matrix type TFT |
| Backlight system | : LED |
| Polarizer | : Anti-Glare treatment |
| Interface | : LVDS |
| Additional circuit | : Timing controller, Power supply (3.3V input) With Constant current circuit for LED Backlight(12V input) |

3. Mechanical specifications

| Item | Specification | Unit |
|-----------------------|--|------|
| Outline dimensions 1) | 199.5(W)×149(H)×(11.5)(D) | mm |
| Active area | 170.4(W)×127.8(H) (21.3cm/8.4 inch(Diagonal)) | mm |
| Dot format | 800×(R,G,B)(W)×600(H) | dot |
| Dot pitch | 0.071(W)×0.213(H) | mm |
| Base color 2) | Normally Black | - |
| Mass | TBD | g |

1) Projection not included. Please refer to outline for details.

2) Due to the characteristics of the LCD material, the color varies with environmental temperature.

4. Absolute maximum ratings

4-1. Electrical absolute maximum ratings

| Item | Symbol | Min. | Max. | Unit | |
|--------------------------|---|-----------------|------|----------------------|---|
| Supply voltage(+3.3V) | V _{DD} | -0.3 | 4.0 | V | |
| Supply voltage(+12V) | V _{IN} | -0.3 | 14.0 | V | |
| Input signal voltagee 2) | RxIN _i +, RxIN _i - 1) | V _{I1} | -0.3 | 2.8 | V |
| | CK IN+, CK IN- | V _{I2} | -0.3 | 2.8 | V |
| | SELLVDS | V _{I3} | -0.3 | V _{DD} +0.5 | V |
| | BLBRT, BLEN | V _{I4} | -0.3 | V _{IN} | V |

1) i=0,1,2,3

2) V_{DD} must be supplied correctly within the range described in 5-1.

4-2. Environmental absolute maximum ratings

| Item | Symbol | Min. | Max. | Unit |
|-----------------------------------|---------------------------|------|------|------|
| Operating temperature(Ambient) 1) | T _{OP} (Ambient) | -30 | 80 | °C |
| Operating temperature(Panel) 2) | T _{OP} (Panel) | -30 | 80 | |
| Storage temperature 3) | T _{STO} | -30 | 80 | °C |
| Operating humidity 4) | H _{OP} | 10 | 5) | %RH |
| Storage humidity 4) | H _{STO} | 10 | 5) | %RH |
| Vibration | - | 6) | 6) | - |
| Shock | - | 7) | 7) | - |

1) Operating temperature means a temperature which operation shall be guaranteed. Since display performance is evaluated at 25°C, another temperature range should be confirmed.

2) Panel surface temperature (all the surface)

3) Temp. = -30°C < 48h , Temp. = 80°C < 168h

Store LCD at normal temperature/humidity. Keep them free from vibration and shock.

An LCD that is kept at a low or a high temperature for a long time can be defective due to other conditions, even if the low or high temperature satisfies the standard.

(Please refer to “Precautions for Use” for details.)

3) Non-condensing

4) Temp. ≤ 40°C, 85%RH Max.

Temp. > 40°C, Absolute humidity shall be less than 85%RH at 40°C.

5)

| | | |
|-----------------|-------------|---|
| Frequency | 10~55 Hz | Acceleration value (0.3~9 m/s ²) |
| Vibration width | 0.15mm | |
| Interval | 10-55-10 Hz | 1 minutes |

2 hours in each direction X, Y, Z (6 hours total)

EIAJ ED-2531

6) Acceleration: 490 m/s², Pulse width: 11 ms

3 times in each direction: ±X, ±Y, ±Z

EIAJ ED-2531

5. Electrical characteristics

5-1. LCD

Temp. = -30~80°C

| Item | Symbol | Condition | Min. | Typ. | Max. | Unit |
|--|----------|---------------|--------------|------|--------------|----------|
| Supply voltage 1) | V_{DD} | - | 3.0 | 3.3 | 3.6 | V |
| Current consumption | I_{DD} | 2) | - | 270 | 350 | mA |
| Permissible input ripple voltage | V_{RP} | $V_{DD}=3.3V$ | - | - | 100 | mVp-p |
| Input signal voltage 3) | V_{IL} | "Low" level | 0 | - | 0.8 | V |
| | V_{IH} | "High" level | 2.0 | - | V_{DD} | V |
| Input leak current | I_{OL} | $V_{I3}=0V$ | -10 | - | 10 | μA |
| | I_{OH} | $V_{I3}=3.3V$ | - | - | 400 | μA |
| LVDS Input voltage 4) | V_L | - | 0 | - | 1.9 | V |
| Differential input voltage 4) | V_{ID} | - | 250 | 350 | 450 | mV |
| Differential input threshold voltage 4) 5) | V_{TL} | "Low" level | $V_{CM}-100$ | - | - | mV |
| | V_{TH} | "High" level | - | - | $V_{CM}+100$ | mV |
| Terminator | R_1 | - | - | 100 | - | Ω |
| V_{DD} -turn-on conditions 1) | t_1 | - | 0.1 | - | 10 | ms |
| | t_2 | - | 0 | - | - | ms |
| | t_3 | - | 0 | - | - | ms |
| | t_4 | - | 1.0 | - | - | s |
| | t_5 | - | 200 | - | - | ms |
| | t_6 | - | 200 | - | - | ms |

1) V_{DD} -turn-on conditions

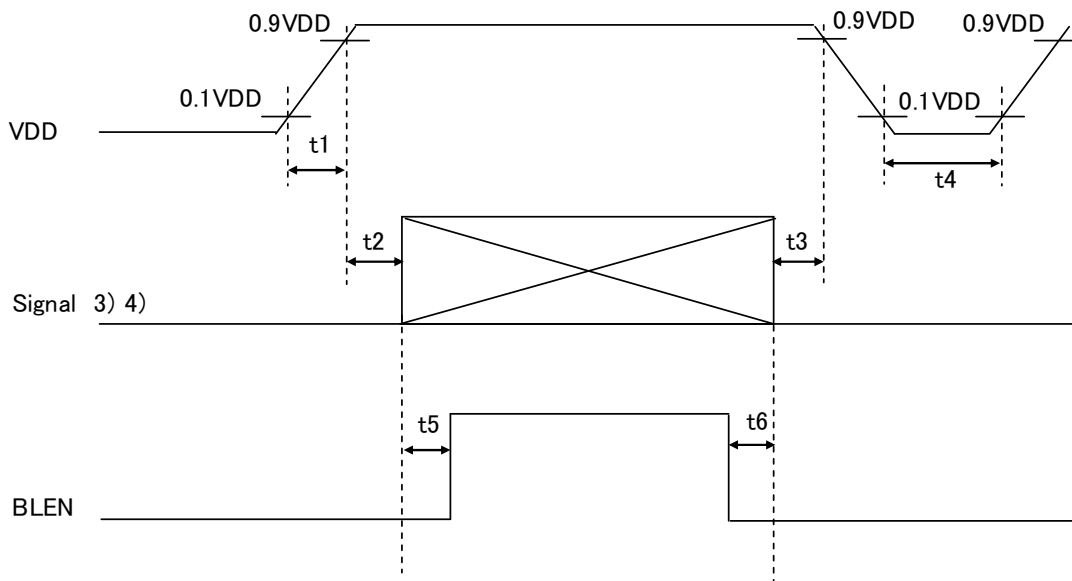

2) Display pattern:

V_{DD} = 3.3V, Temp. = 25°C

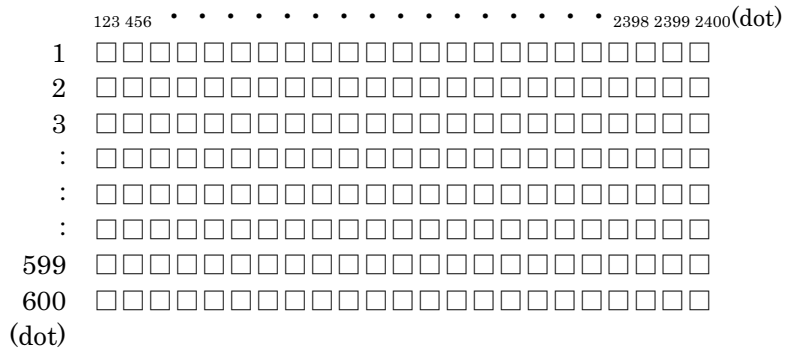

3) Input signal : SELLVDS

4) Input signal : RxIN3+, RxIN3-, RxIN2+, RxIN2-, RxIN1+, RxIN1-, RxIN0+, RxIN0-
CK IN+, CK IN-

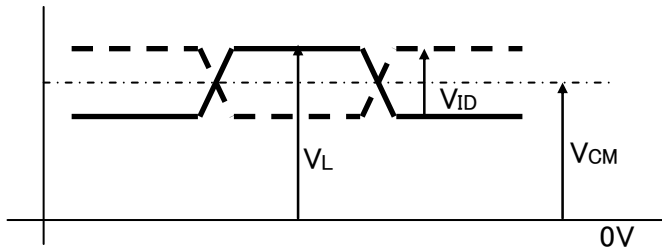

5) V_{CM} : LVDS Common mode voltage (V_{CM}=1.25V)

5-2. Constant current circuit for LED Backlight

Temp. = -30~80°C

| Item | Symbol | Condition | Min. | Typ. | Max. | Unit |
|----------------------------------|-----------------|-----------------|------|----------|----------|------------|
| Supply voltage 1) | V_{IN} | - | 10.8 | 12.0 | 13.2 | V |
| Current consumption | I_{IN} | 2) | - | (770) | (1000) | mA |
| Permissive input ripple voltage | V_{RP_BL} | $V_{IN}=12.0V$ | - | - | 100 | mVp-p |
| BLBRT Input signal voltage | V_{IL_BLBRT} | "Low" level | 0 | - | 0.8 | V |
| | V_{IH_BLBRT} | "High" level | 2.3 | - | V_{IN} | V |
| BLBRT Input pull-down resistance | R_{IN_BLBRT} | - | 100 | 300 | 500 | k Ω |
| BLEN Input signal voltage | V_{IL_BLEN} | "Low" level | 0 | - | 0.8 | V |
| | V_{IH_BLEN} | "High" level | 2.3 | - | V_{IN} | V |
| BLEN Input pull-down resistance | R_{IN_BLEN} | - | 100 | 300 | 500 | k Ω |
| PWM Frequency 3) | f_{PWM} | - | 200 | - | 10k | Hz |
| PWM Duty ratio | D_{PWM} | $f_{PWM}=200Hz$ | 1 | - | 100 | % |
| | | $f_{PWM}=2kHz$ | 10 | - | 100 | % |
| | | $f_{PWM}=10kHz$ | 50 | - | 100 | % |
| Operating life time 4), 5) | T | Temp.=25°C | - | (70,000) | - | h |

【LED Circuit】

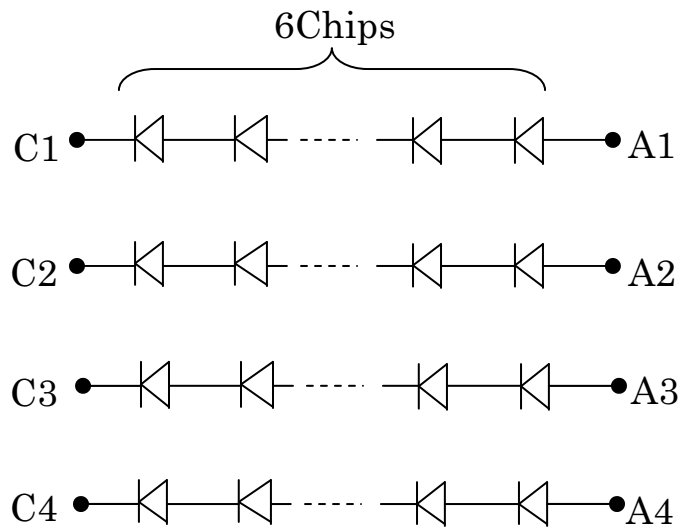

1) V_{IN} -turn-on conditions

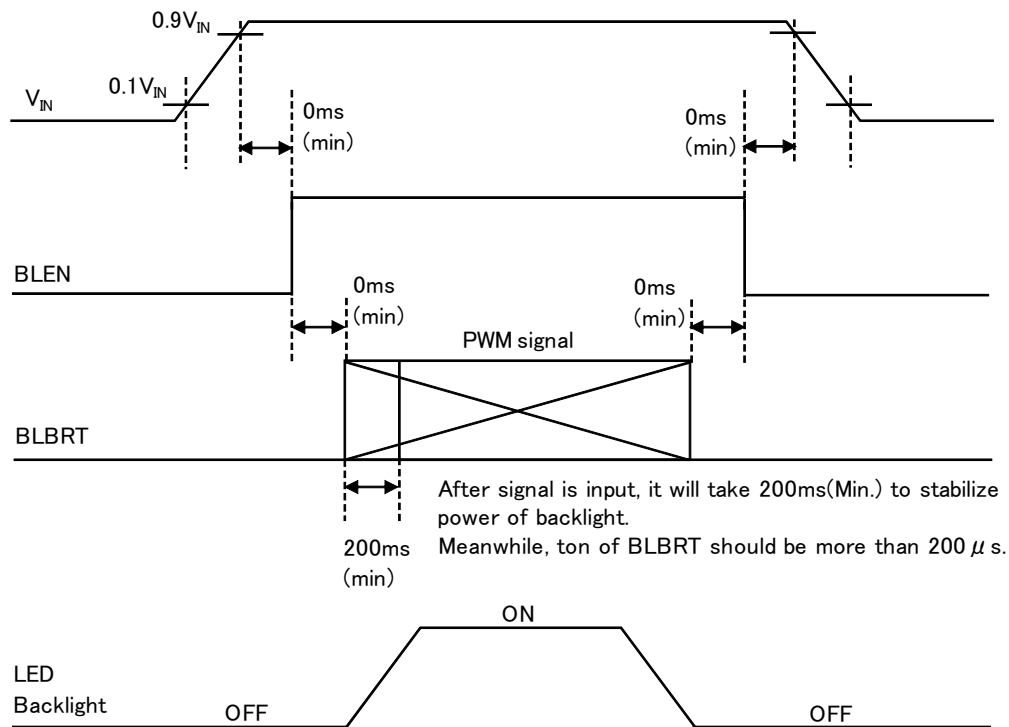

2) $V_{IN} = 12V$, Temp. = 25°C, $D_{PWM} = 100\%$

3) PWM Timing Diagram

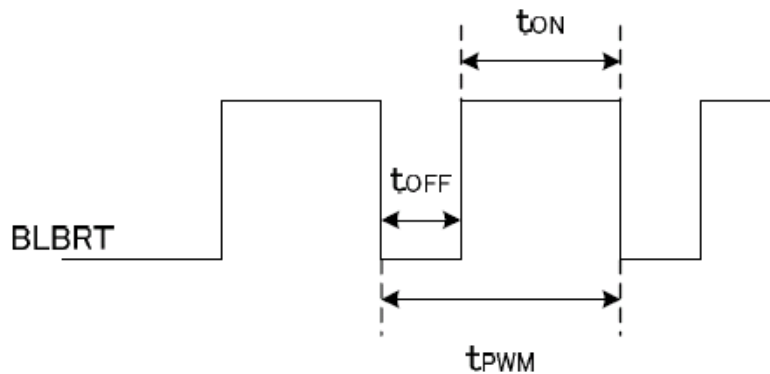

$t_{ON}, t_{OFF} \geq 50 \mu s$.

In case of lower frequency, the deterioration of the display quality, flicker etc., may occur.

- 4) When brightness decrease 50% of minimum brightness.
The average life of a LED will decrease when the LCD is operating at higher temperatures.
- 5) Life time is estimated data. (Condition : $I_F=100mA$, $T_a=25^\circ C$ in chamber).

6. Optical characteristics

Measuring spot = ϕ 6.0mm, Temp. = 25°C

| Item | Symbol | Condition | Min. | Typ. | Max. | Unit | |
|--------------------------|----------------|---------------------------|---------------------------|--------|------|-------------------|----|
| Response time | Rise | τ_r | $\theta = \phi = 0^\circ$ | - | 18 | - | ms |
| | Down | τ_d | $\theta = \phi = 0^\circ$ | - | 12 | - | ms |
| Viewing angle range | θ UPPER | CR \geq 10 | - | 85 | - | deg. | |
| | θ LOWER | | - | 85 | - | | |
| | ϕ LEFT | | - | 85 | - | deg. | |
| | ϕ RIGHT | | - | 85 | - | | |
| Contrast ratio | CR | $\theta = \phi = 0^\circ$ | (500) | (750) | - | - | |
| Brightness | L | IF=100mA/Line | - | (1200) | - | cd/m ² | |
| Chromaticity coordinates | Red | x | $\theta = \phi = 0^\circ$ | TBD | TBD | TBD | |
| | | y | | TBD | TBD | TBD | |
| | Green | x | $\theta = \phi = 0^\circ$ | TBD | TBD | TBD | |
| | | y | | TBD | TBD | TBD | |
| | Blue | x | $\theta = \phi = 0^\circ$ | TBD | TBD | TBD | |
| | | y | | TBD | TBD | TBD | |
| | White | x | $\theta = \phi = 0^\circ$ | TBD | TBD | TBD | |
| | | y | | TBD | TBD | TBD | |

6-1. Definition of contrast ratio

$$\text{CR(Contrast ratio)} = \frac{\text{Brightness with all pixels "White"}}{\text{Brightness with all pixels "Black"}}$$

6-2. Definition of response time

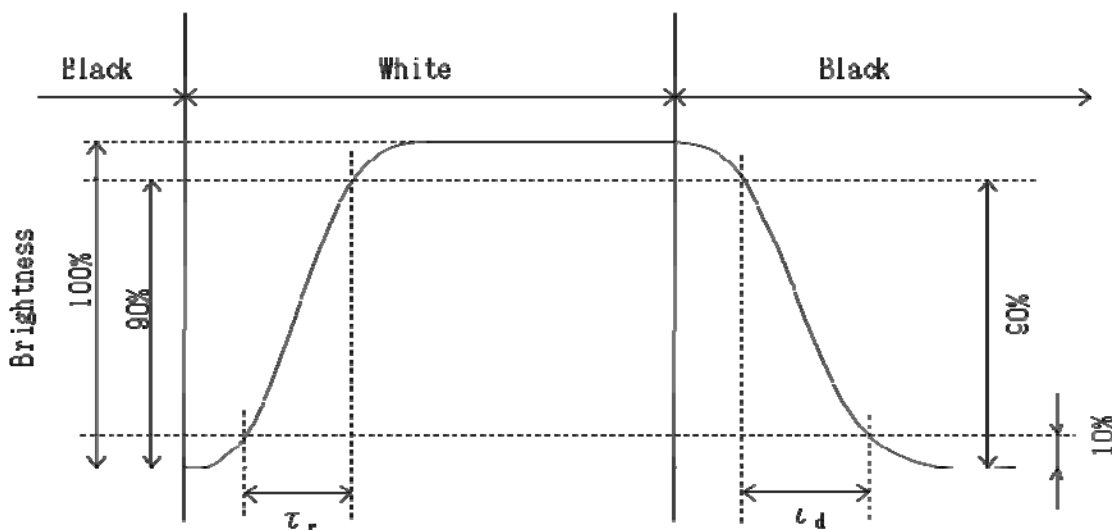

6-3. Definition of viewing angle

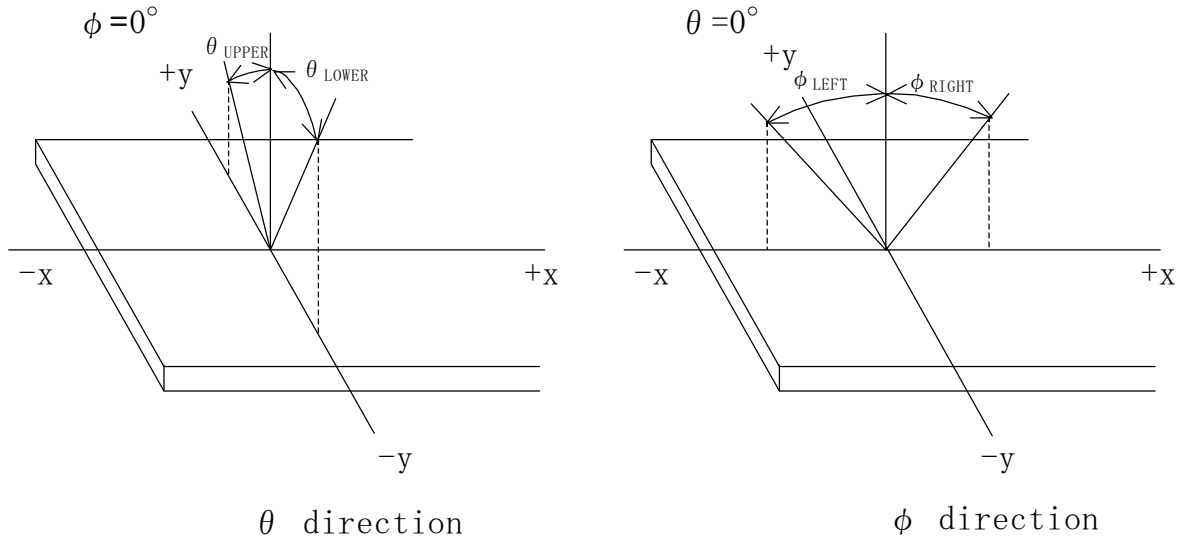

6-4. Brightness measuring points

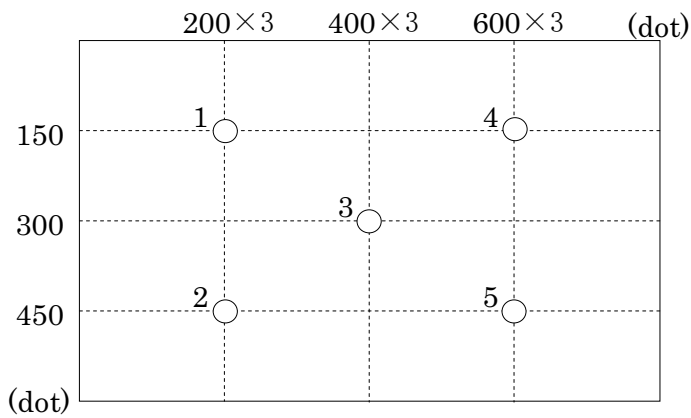

- 1) Rating is defined as the white brightness at center of display screen(3).
- 2) 5 minutes after LED is turned on. (Ambient Temp.=25°C)

7. Interface signals

7-1. Interface signals

| No. | Symbol | Description | Note |
|-----|-----------------|---------------------------------------|------|
| 1 | GND | GND | |
| 2 | SELLVDS | Mode select signal(LVDS Data mapping) | |
| 3 | GND | GND | |
| 4 | GND | GND | |
| 5 | RxIN3+ | LVDS receiver signal CH3(+) | LVDS |
| 6 | RxIN3- | LVDS receiver signal CH3(-) | LVDS |
| 7 | GND | GND | |
| 8 | CK IN+ | LVDS receiver signal CK(+) | LVDS |
| 9 | CK IN- | LVDS receiver signal CK(-) | LVDS |
| 10 | GND | GND | |
| 11 | RxIN2+ | LVDS receiver signal CH2(+) | LVDS |
| 12 | RxIN2- | LVDS receiver signal CH2(-) | LVDS |
| 13 | GND | GND | |
| 14 | RxIN1+ | LVDS receiver signal CH1(+) | LVDS |
| 15 | RxIN1- | LVDS receiver signal CH1(-) | LVDS |
| 16 | GND | GND | |
| 17 | RxIN0+ | LVDS receiver signal CH0(+) | LVDS |
| 18 | RxIN0- | LVDS receiver signal CH0(-) | LVDS |
| 19 | GND | GND | |
| 20 | GND | GND | |
| 21 | V _{DD} | +3.3V power supply | |
| 22 | V _{DD} | +3.3V power supply | |
| 23 | GND | GND | |
| 24 | BLBRT | PWM signal(Brightness adjustment) | |
| 25 | BLEN | ON/OFF terminal voltage | |
| 26 | GND | GND | |
| 27 | V _{IN} | +12V power supply | |
| 28 | V _{IN} | +12V power supply | |
| 29 | GND | GND | |
| 30 | GND | GND | |

LCD connector : FI-X30SSLA-HF (JAE)
 Matching connector : FI-X30HL (JAE)
 : FI-X30HL-T (JAE)
 : FI-X30C2L-NPB (JAE)
 : FI-X30C2L-T-NPB (JAE)

LVDS receiver : Embedded in ASIC
 Matching LVDS transmitter : THC63LVDM83R(Thine Electronics) or compatible

7-2. Data mapping(6bit RGB input)

1) Location of SELLVDS (THC63LVDM83R(THine Electronics) or compatible)

| Transmitter | | 2Pin SELLVDS | |
|-------------|------|------------------|-----------|
| Pin No. | Data | = L(GND) or OPEN | = H(3.3V) |
| 51 | TA0 | — | R0(LSB) |
| 52 | TA1 | — | R1 |
| 54 | TA2 | — | R2 |
| 55 | TA3 | — | R3 |
| 56 | TA4 | — | R4 |
| 3 | TA5 | — | R5(MSB) |
| 4 | TA6 | — | G0(LSB) |
| 6 | TB0 | — | G1 |
| 7 | TB1 | — | G2 |
| 11 | TB2 | — | G3 |
| 12 | TB3 | — | G4 |
| 14 | TB4 | — | G5(MSB) |
| 15 | TB5 | — | B0(LSB) |
| 19 | TB6 | — | B1 |
| 20 | TC0 | — | B2 |
| 22 | TC1 | — | B3 |
| 23 | TC2 | — | B4 |
| 24 | TC3 | — | B5(MSB) |
| 27 | TC4 | — | (HS) |
| 28 | TC5 | — | (VS) |
| 30 | TC6 | — | DE |
| 50 | TD0 | — | GND |
| 2 | TD1 | — | GND |
| 8 | TD2 | — | GND |
| 10 | TD3 | — | GND |
| 16 | TD4 | — | GND |
| 18 | TD5 | — | GND |
| 25 | TD6 | — | GND |

SELLVDS=H(3.3V)

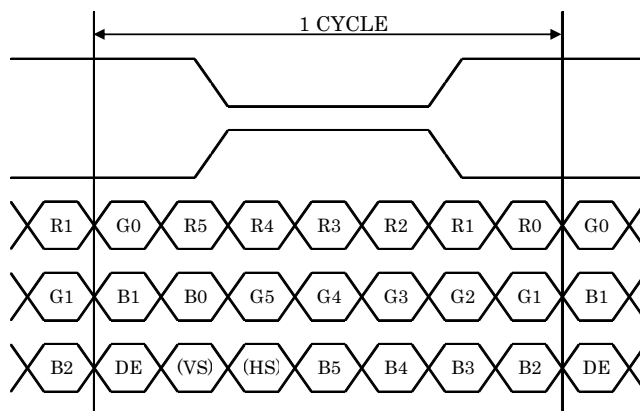

DE : DATA ENABLE

HS : H_{SYNC}

VS : V_{SYNC}

2) Block Diagram

SELLVDS=H(3.3V)

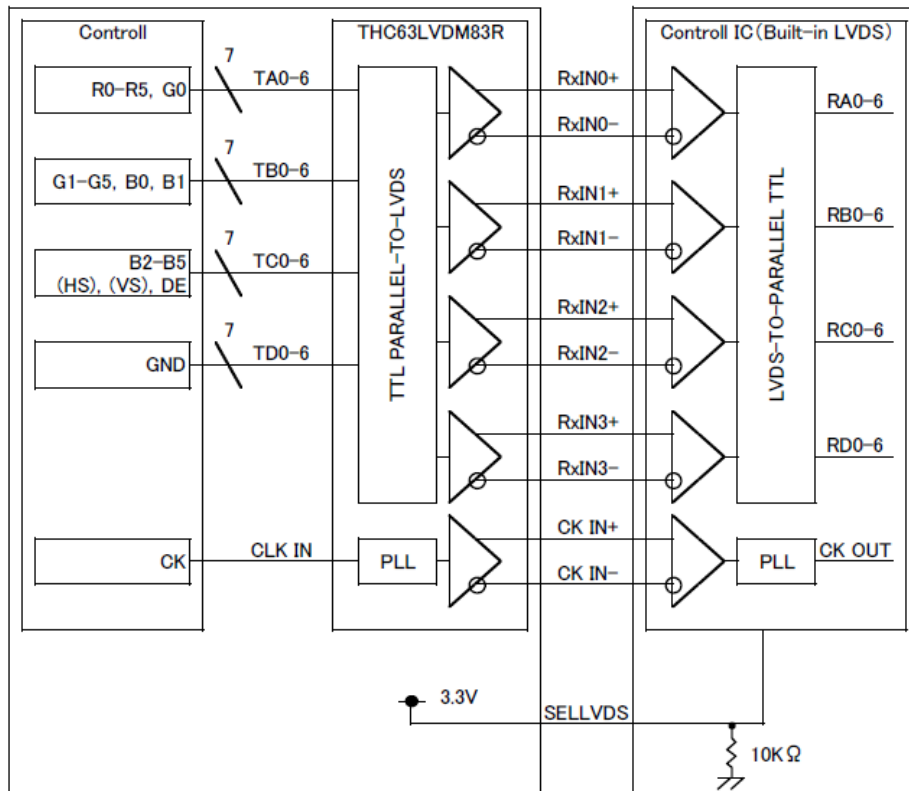

When using “6-bit Transmitter”, please connect the unused channel of the control IC receiver as described in the diagram below.

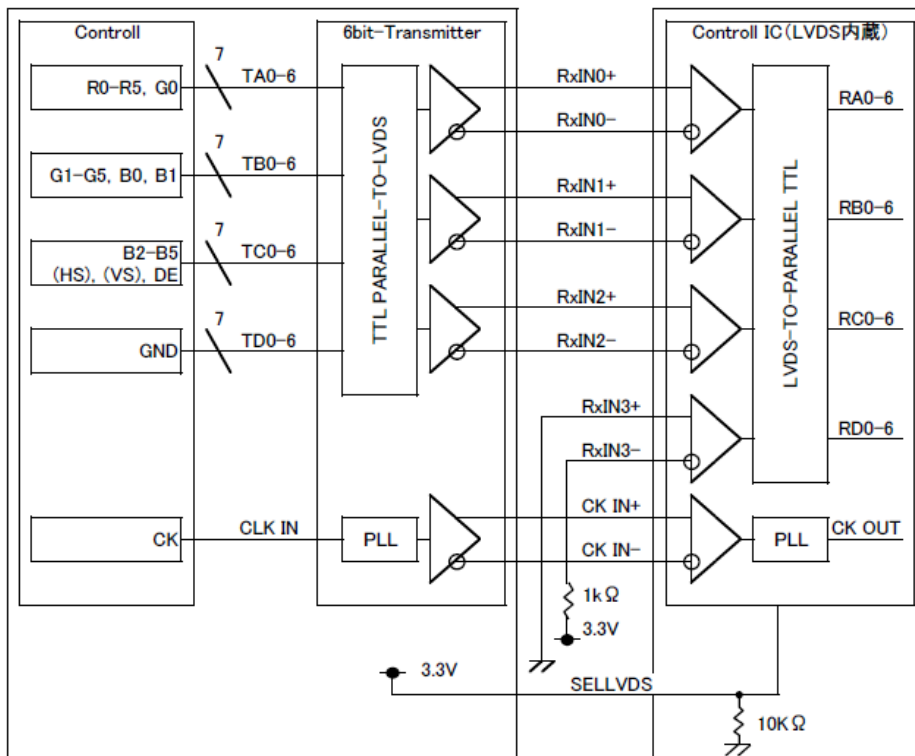

7-3. Data mapping(8bit RGB input)

1) Location of SELLVDS (THC63LVDM83R(THine Electronics) or compatible)

| Transmitter | | 2Pin SELLVDS | |
|-------------|------|------------------|-----------|
| Pin No. | Data | = L(GND) or OPEN | = H(3.3V) |
| 51 | TA0 | R0(LSB) | R2 |
| 52 | TA1 | R1 | R3 |
| 54 | TA2 | R2 | R4 |
| 55 | TA3 | R3 | R5 |
| 56 | TA4 | R4 | R6 |
| 3 | TA5 | R5 | R7(MSB) |
| 4 | TA6 | G0(LSB) | G2 |
| 6 | TB0 | G1 | G3 |
| 7 | TB1 | G2 | G4 |
| 11 | TB2 | G3 | G5 |
| 12 | TB3 | G4 | G6 |
| 14 | TB4 | G5 | G7(MSB) |
| 15 | TB5 | B0(LSB) | B2 |
| 19 | TB6 | B1 | B3 |
| 20 | TC0 | B2 | B4 |
| 22 | TC1 | B3 | B5 |
| 23 | TC2 | B4 | B6 |
| 24 | TC3 | B5 | B7(MSB) |
| 27 | TC4 | (HS) | (HS) |
| 28 | TC5 | (VS) | (VS) |
| 30 | TC6 | DE | DE |
| 50 | TD0 | R6 | R0(LSB) |
| 2 | TD1 | R7(MSB) | R1 |
| 8 | TD2 | G6 | G0(LSB) |
| 10 | TD3 | G7(MSB) | G1 |
| 16 | TD4 | B6 | B0(LSB) |
| 18 | TD5 | B7(MSB) | B1 |
| 25 | TD6 | (NA) | (NA) |

SELLVDS=L(GND) or OPEN

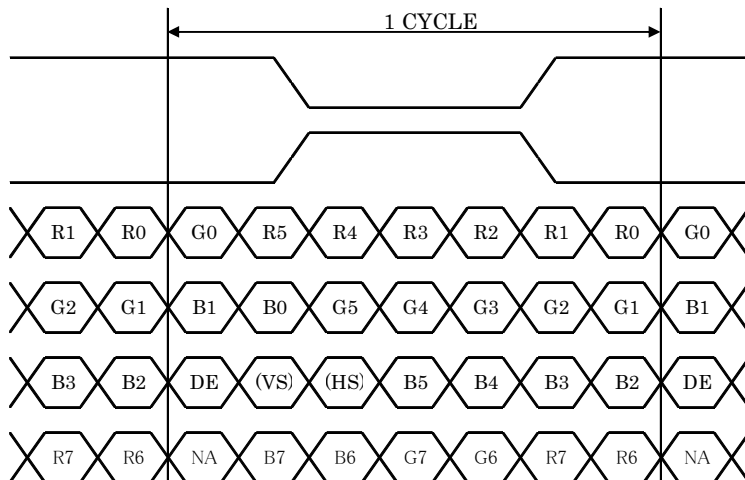

DE : DATA ENABLE

HS : H_{SYNC}

VS : V_{SYNC}

SELLVDS=H(3.3V)

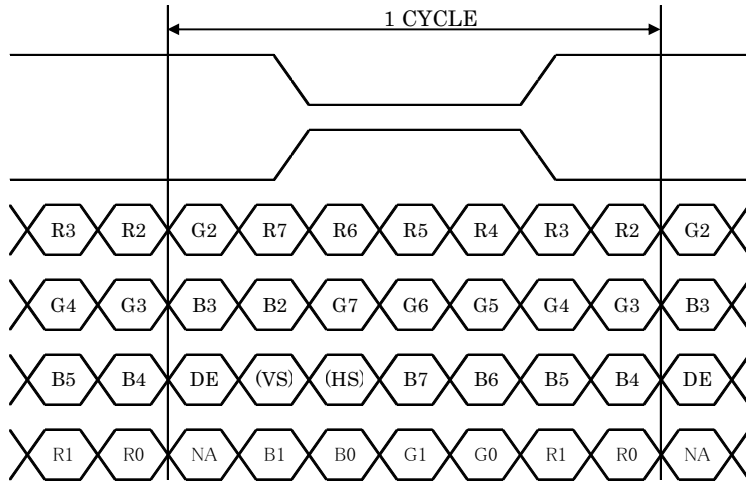

DE : DATA ENABLE
HS : Hsync
VS : Vsync

2) Block Diagram

SELLVDS=L(GND) or OPEN

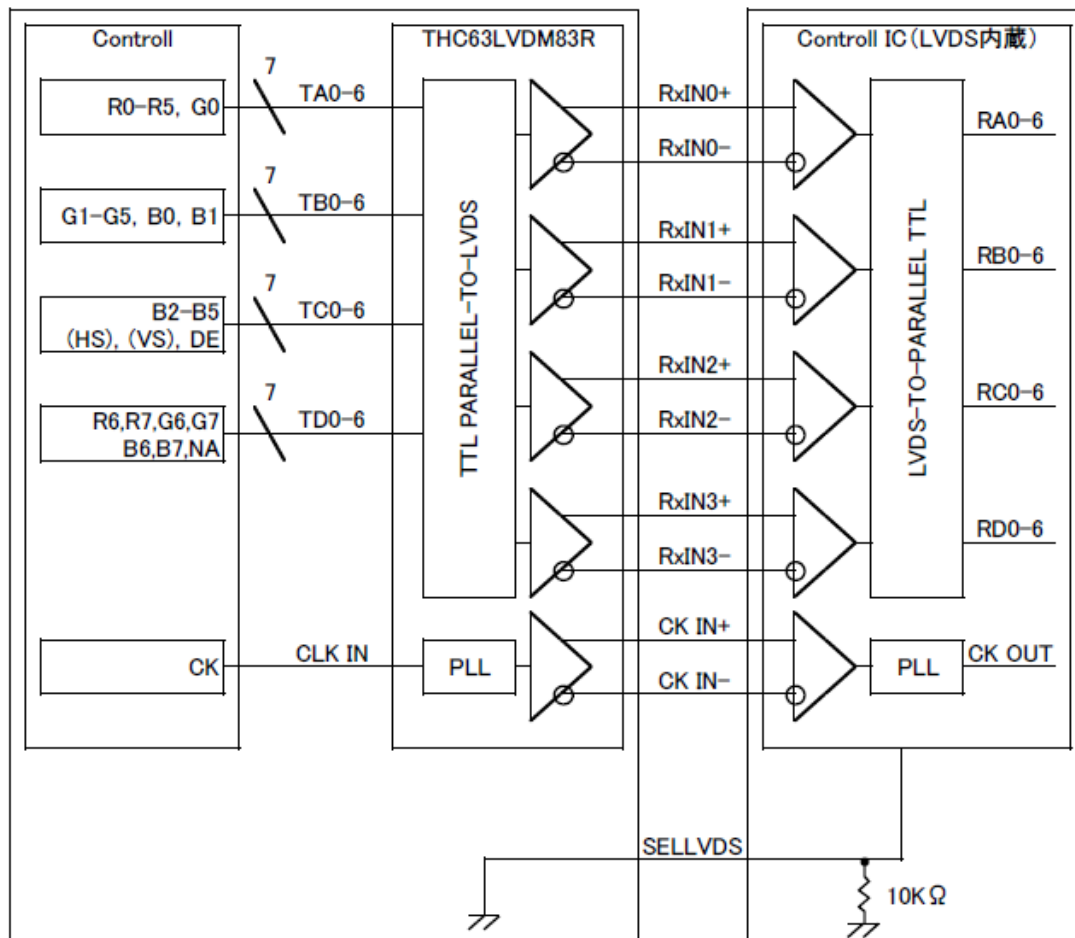

SELLVDS=H(3.3V)

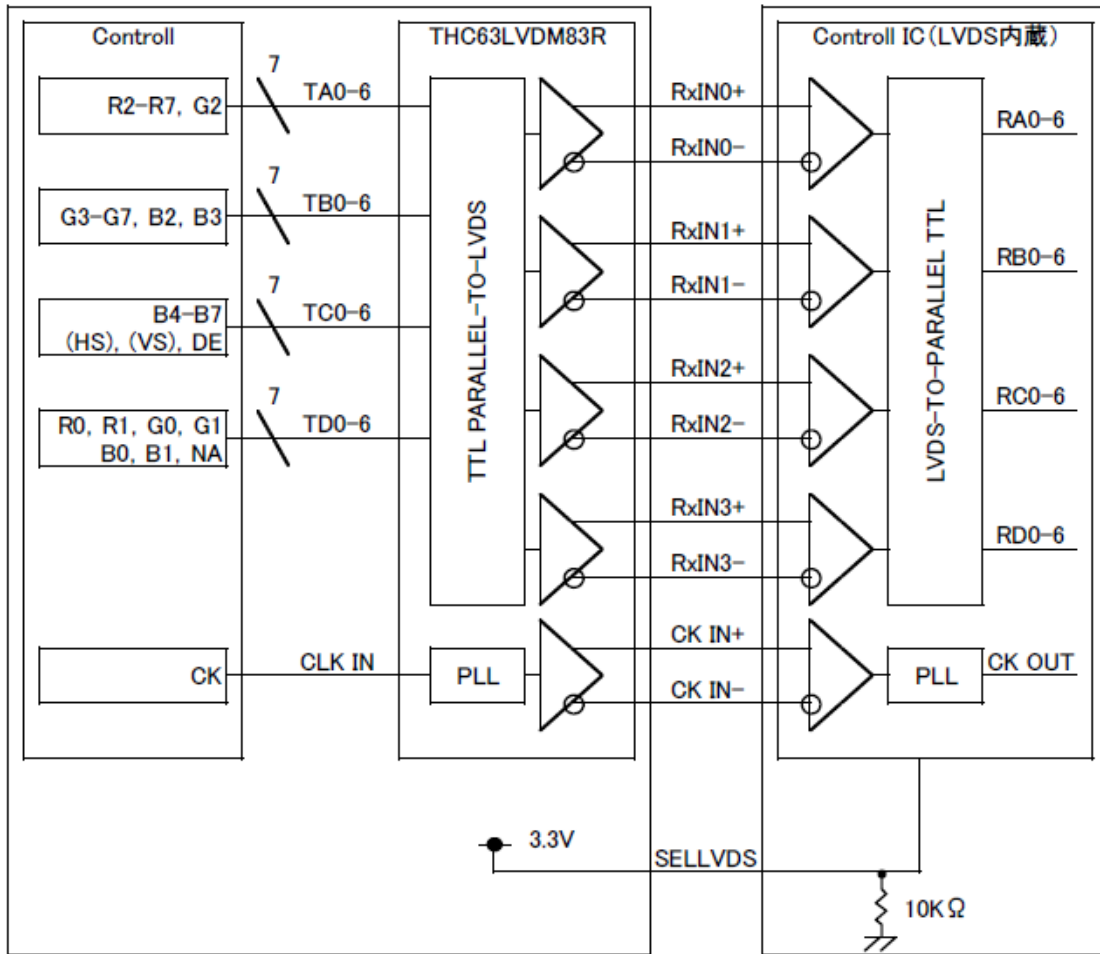

8. Input timing characteristics

8-1. Timing characteristics

| Item | | Symbol | Min. | Typ. | Max. | Unit | Note |
|--------------------|---------------------------|--------|------|------|------|------|------|
| Clock (CK) | Frequency | 1/Tc | 30 | 40 | 48 | MHz | |
| Enable signal (DE) | Horizontal Period | Th | 860 | 1056 | 1395 | Tc | |
| | | | 24.0 | 26.4 | - | μs | 1) |
| | Horizontal display period | Thd | 800 | | | Tc | |
| | Vertical Period | Tv | 610 | 628 | 1024 | Th | |
| | Vertical display period | Tvd | 600 | | | Th | |
| Refresh rate | | fv | 50 | 60 | 70 | Hz | 2) |

1) Please set a clock frequency, a vertical dormant period, and the horizontal dormant period so that the Horizontal Period should not reach less than Min. value.

2) If the refresh rate reach less than Min. value, the deterioration of the display quality, flicker etc., may occur.(fv=1/Tv)

Vertical Timing Diagram

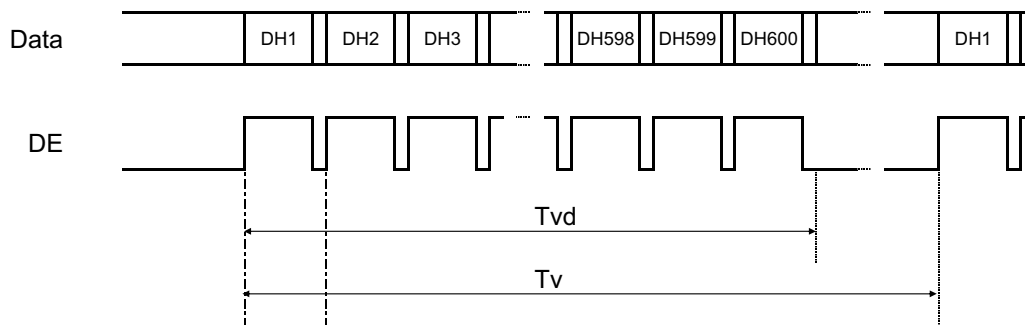

Horizontal Timing Diagram

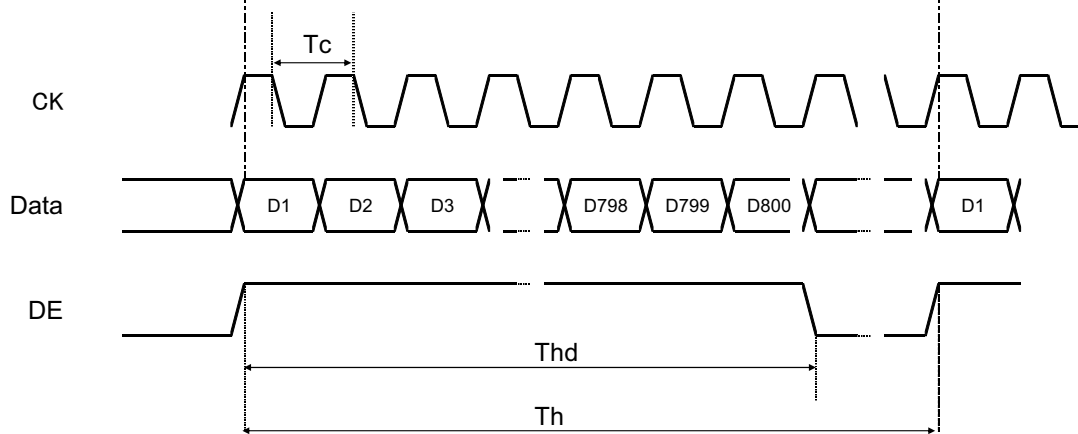

8-2. Input Data Signals and Display position on the screen

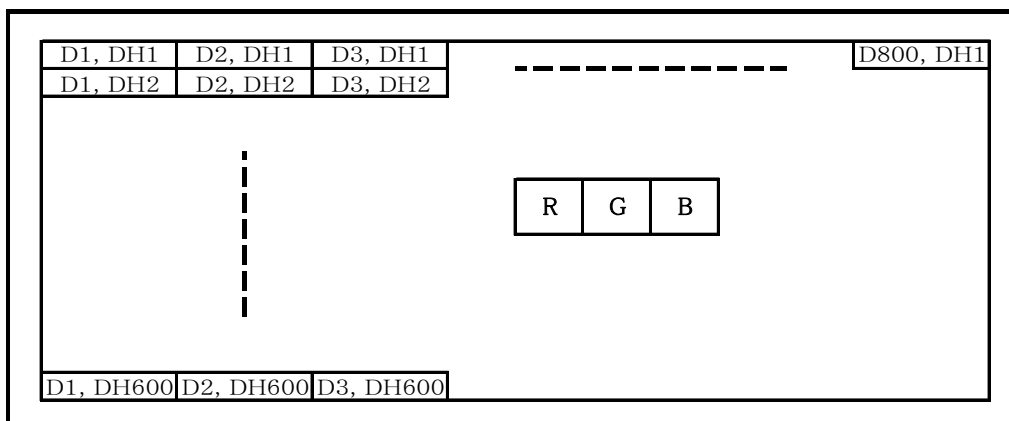

9. Lot number identification

The lot number shall be indicated on the back of the backlight case of each LCD.

TCG084SVLQ*PNN-AN*33 - □□ - □□ - □ MADE IN □□□□□
 ↓↓ ↓ ↓ ↓ ↓
 1 2 3 4 5

No1. - No5. above indicate
 1. Year code
 2. Month code
 3. Date
 4. Version Number
 5. Country of origin (Japan or China)

| | | | | | | |
|------|------|------|------|------|------|------|
| Year | 2014 | 2015 | 2016 | 2017 | 2018 | 2019 |
| Code | 4 | 5 | 6 | 7 | 8 | 9 |

| | | | | | | |
|-------|------|------|------|------|-----|------|
| Month | Jan. | Feb. | Mar. | Apr. | May | Jun. |
| Code | 1 | 2 | 3 | 4 | 5 | 6 |

| | | | | | | |
|-------|------|------|------|------|------|------|
| Month | Jul. | Aug. | Sep. | Oct. | Nov. | Dec. |
| Code | 7 | 8 | 9 | X | Y | Z |

10. Warranty

10-1. Incoming inspection

Please inspect the LCD within one month after your receipt.

10-2. Production warranty

Kyocera display warrants its LCD's for a period of 12 months from the ship date. Kyocera display shall, by mutual agreement, replace or re-work defective LCD's that are shown to be Kyocera display's responsibility.

11. Precautions for use

11-1. Installation of the LCD

- 1) Please ground either of the mounting (screw) holes of LCD, in order to stabilize brightness and display quality.
- 2) A transparent protection plate shall be added to protect the LCD and its polarizer.
- 3) The LCD shall be installed so that there is no pressure on the LSI chips.
- 4) Since this product is wide viewing product, occurrence level of in-plane unevenness by the external stress is different compared to current normal viewing product. So there is a possibility that in-plane unevenness will be occurred by over twist, strain giving by attaching to LCD, and over pressure to touch panel. Please be careful of stress when designing the housing.
- 5) A transparent protection sheet is attached to the polarizer. Please remove the protection film slowly before use, paying attention to static electricity.

11-2. Static electricity

- 1) Since CMOS ICs are mounted directly onto the LCD glass, protection from static electricity is required.
- 2) Workers should use body grounding. Operator should wear ground straps.

11-3. LCD operation

- 1) The LCD shall be operated within the limits specified. Operation at values outside of these limits may shorten life, and/or harm display images.
- 2) Please select the best display pattern based on your evaluation because flicker, lines or nonuniformity or unevenness can be visible depending on display patterns.

11-4. Storage

- 1) The LCD shall be stored within the temperature and humidity limits specified.
Store in a dark area, and protect the LCD from direct sunlight or fluorescent light.
- 2) Always store the LCD so that it is free from external pressure onto it.

11-5. Usage

- 1) **DO NOT** store in a high humidity environment for extended periods. Polarizer degradation bubbles, and/or peeling off of the polarizer may result.
- 2) The front polarizer is easily scratched or damaged. Prevent touching it with any hard material, and from being pushed or rubbed.
- 3) The LCD screen may be cleaned by wiping the screen surface with a soft cloth or cotton pad using a little Ethanol.
- 4) Water may cause damage or discoloration of the polarizer. Clean condensation or moisture from any source immediately.
- 5) Always keep the LCD free from condensation during testing. Condensation may permanently spot or stain the polarizer.
- 6) Do not disassemble LCD because it will result in damage.
- 7) This Kyocera display LCD has been specifically designed for use in general electronic devices, but not for use in a special environment such as usage in an active gas. Hence, when the LCD is supposed to be used in a special environment, evaluate the LCD thoroughly beforehand and do not expose the LCD to chemicals such as an active gas.
- 8) Please do not use solid-base image pattern for long hours because a temporary afterimage may appear. We recommend using screen saver etc. in cases where a solid-base image pattern must be used.
- 9) Liquid crystal may leak when the LCD is broken. Be careful not to let the fluid go into your eyes and mouth. In the case the fluid touches your body; rinse it off right away with water and soap.

12. Reliability test data

| Test item | Test condition | Test time | Judgement |
|--------------------------------|--------------------------------------|------------|--|
| High temp. atmosphere | 80°C | (240h) | Display function : No defect Display quality : No defect Current consumption : No defect |
| Low temp. atmosphere | -30°C | (240h) | Display function : No defect Display quality : No defect Current consumption : No defect |
| High temp. humidity atmosphere | 40°C 90% RH | (240h) | Display function : No defect Display quality : No defect Current consumption : No defect |
| Temp. cycle | -30°C 0.5h R.T. 0.5h 80°C 0.5h | (10cycles) | Display function : No defect Display quality : No defect Current consumption : No defect |
| High temp. operation | 80°C | (500h) | Display function : No defect Display quality : No defect Current consumption : No defect |

- 1) Each test item uses a test LCD only once. The tested LCD is not used in any other tests.
- 2) The LCD is tested in circumstances in which there is no condensation.
- 3) The reliability test is not an out-going inspection.
- 4) The result of the reliability test is for your reference purpose only.
The reliability test is conducted only to examine the LCD's capability.

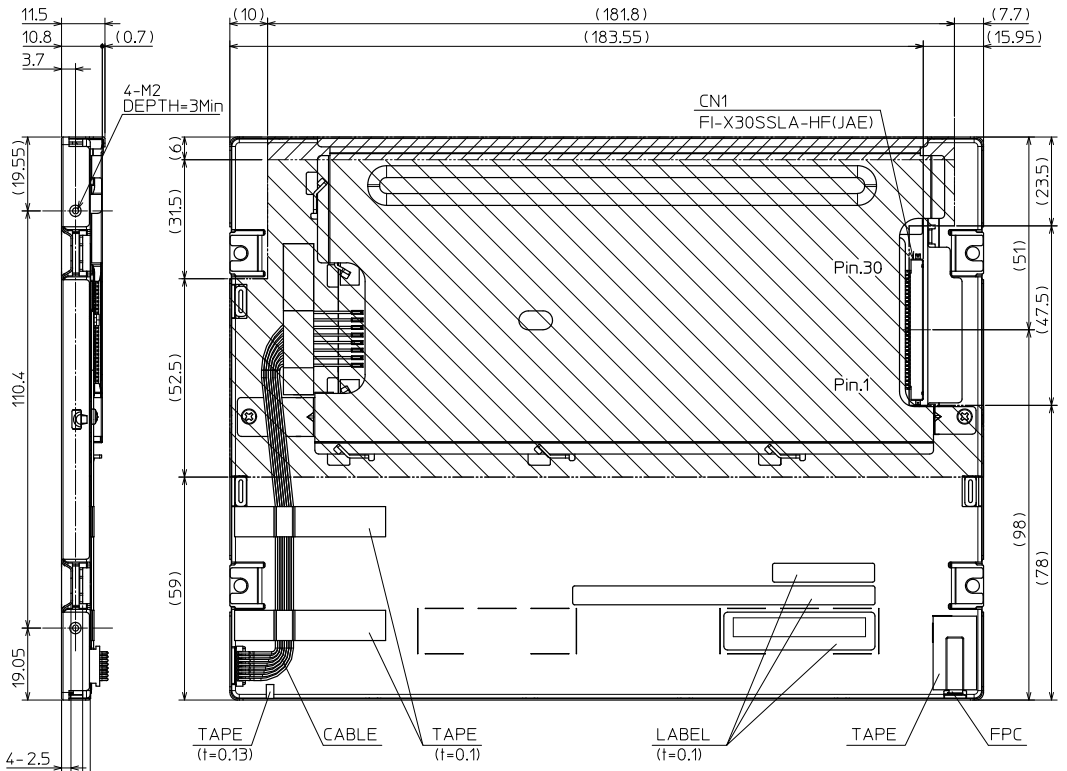
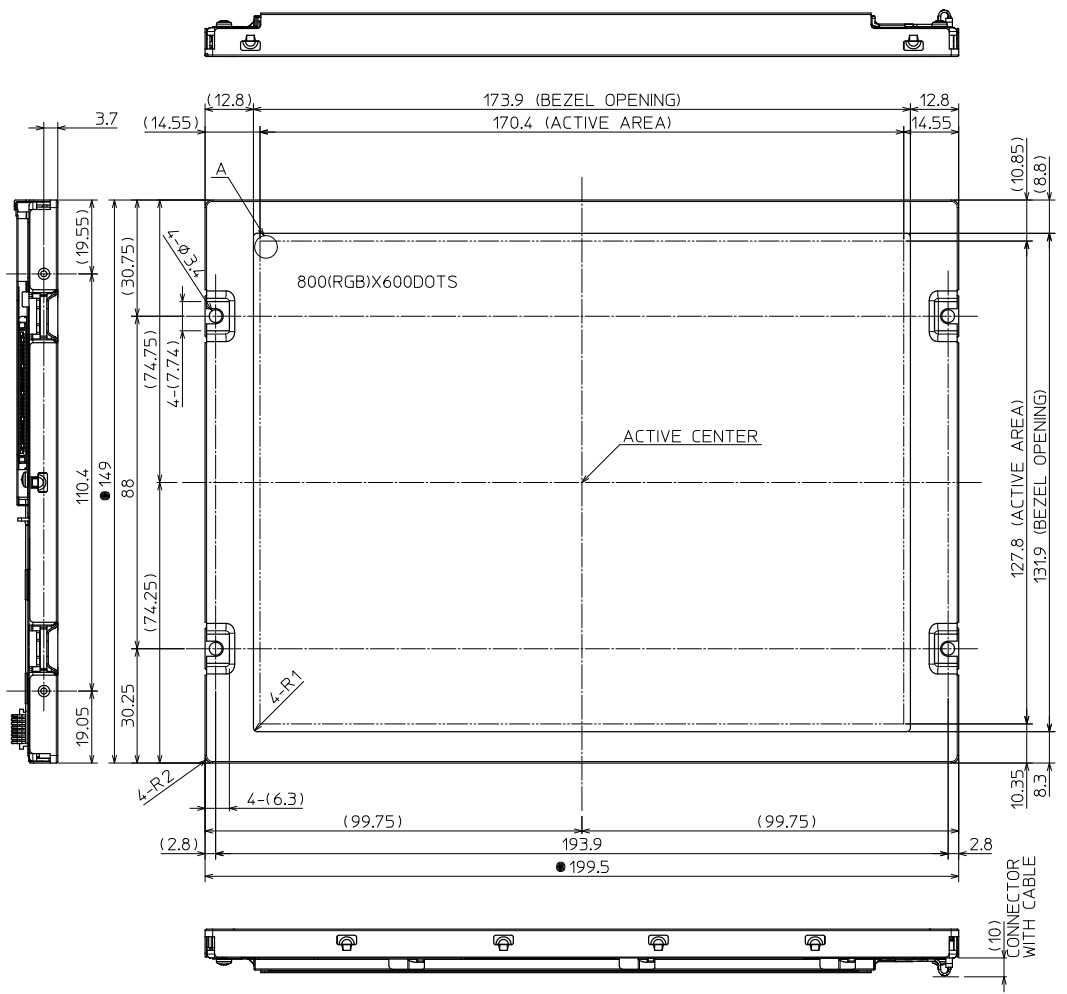

:Projected part is 11.5mm thickness. (厚≠11.5mm)
 :Projected part is 10.8mm thickness. (厚≠10.8mm)



DETAIL A (Dot Size)
(NTS)

| TOLERANCE | | | |
|-----------|------|------|------|
| MEASURE | A | B | C |
| L≦16 | +0.1 | +0.3 | +1 |
| 16<L≦63 | +0.2 | +0.5 | +1.5 |
| 63<L≦250 | +0.3 | +0.8 | +2 |
| 250<L≦500 | +0.5 | +1.2 | +3 |
| 500<L | +0.8 | +2 | +4 |
| ANGLE | +1° | +5° | +10° |

- Notes
- The dimensions with the mark (●) are controlled as a particular characteristic.
●印を付けた寸法・仕様は、弊社の管理特性の指示を表わす。
 - There is a possibility that in-plane unevenness will be occurred by over twist, stress giving by attaching to LCD, and over pressure to touch panel. Please be careful of stress when designing the housing.
過度な捻り（ひずみ）、LCD固定時の応力発生、タッチパネルでの過度の押し圧によっては、パネル面内にムラが発生することがありますので、筐体設計において、事前に十分確認願います。
 - Tolerance without indication: ±0.5
指示なき公差
 - Max screw length: 3Max.
最長ねじ長さ
 - Max screw torque: **kgf・cm
最大トルク

NAME **TCG084SVLQ*PNN-AN*33**
 DWG NUMBER **121A8071800**

| | | | |
|----------------------------|------------------------|--------------------------------------|---------|
| MATERIAL: | | FINISH: | |
| DATE 2013/11/25 | THIRD ANGLE PROJECTION | KYOCERA Display Corporation | |
| APPROVED S.SAKURA | SCALE UNIT 1:1 mm | TITLE DIMENSION OUTLINE | |
| CHECKED MKATO MKAGEYAMA | DATE '13.11.22 | DWG NO(CODE) T-55786GD084J-LW-AHN | |
| DRAWN SKURAMOTO | DSGN SKURAMOTO | DWG SIZE A2 | DWG REV |

| | |
|----------|-----------------------|
| Spec No. | TQ3C-8EAF0-E2TAB02-00 |
| Date | January 21, 2014 |

KYOCERA INSPECTION STANDARD

TYPE : T-55786GD084J-LW-AHN
(TCG084SVLQ*PNN-AN*33)

KYOCERA DISPLAY CORPORATION

| Original Issue Date | Designed by : Engineering dept. | | | Confirmed by : QA dept. | |
|---------------------|---------------------------------|------------------|--------------------|-------------------------|------------------|
| | Prepared | Checked | Approved | Checked | Approved |
| January 21, 2014 | <i>T. Cudera</i> | <i>S. Ohtaka</i> | <i>M. Fujitani</i> | <i>O. Sato</i> | <i>I. Hamada</i> |

Spec No.
TQ3C-8EAF0-E2TAB02-00

Part No.
T-55786GD084J-LW-AHN
(TCG084SVLQ*PNN-AN*33)

Page
-

Revision record

| Date | Designed by : Engineering dept. | | | Confirmed by : QA dept. | |
|---------|---------------------------------|---------|--------------|-------------------------|----------|
| | Prepared | Checked | Approved | Checked | Approved |
| | | | | | |
| Rev.No. | Date | Page | Descriptions | | |
| | | | | | |

Visuals specification

1) Note

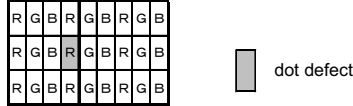
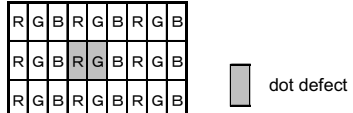
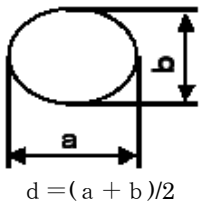
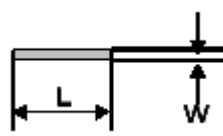
| | | Note | | |
|-------------------------------|--|---|--|--|
| General | <p>1. Customer identified anomalies not defined within this inspection standard shall be reviewed by Kyocera display, and an additional standard shall be determined by mutual consent.</p> <p>2. This inspection standard about the image quality shall be applied to any defect within the active area and shall not be applicable to outside of the area.</p> <p>3. Inspection conditions</p> <p>Luminance : 300 ~ 500 Lux min.</p> <p>Inspection distance : 350 mm.</p> <p>Temperature : Approximate 25°C</p> <p>Direction : Normal to the LCD panel ± 10° horizontal and vertical</p> | | | |
| Definition of inspection item | Dot defect | Bright dot defect | <p>The dot is constantly “on” when power applied to the LCD, even when all “Black” data sent to the screen.</p> <p>Inspection tool: 5% Transparency neutral density filter.</p> <p>Count dot: If the dot is visible through the filter.</p> <p>Don't count dot: If the dot is not visible through the filter.</p>  | |
| | | Black dot defect | <p>The dot is constantly “off” when power applied to the LCD, even when all “White” data sent to the screen.</p> | |
| | | Adjacent dot | <p>Adjacent dot defect is defined as two or more bright dot defects or black dot defects.</p>  | |
| | External inspection | Bubble, Scratch, Foreign particle (Polarizer, Cell, Backlight) | Visible operating (all pixels “Black” or “White”) and non operating. | |
| | | Appearance inspection | Does not satisfy the value at the spec. | |
| Definition of size | Definition of circle size | Definition of linear size | | |
| |  <p>$d = (a + b) / 2$</p> |  | | |

2) Standard

| Defect Type | | Limit | |
|-------------------------|----------------------------|--|------------|
| Visual defect | Scratch | $0.01 \text{ mm} < W \leq 0.05 \text{ mm}$ | $N \leq 4$ |
| | | $L \leq 10 \text{ mm}$ | |
| | | $0.01 \text{ mm} < W$ $10 \text{ mm} < L$ | $N = 0$ |
| | | $0.05 \text{ mm} < W$ | $N = 0$ |
| | Dent | $0.2 \text{ mm} < \Phi \leq 0.4 \text{ mm}$ | $N \leq 4$ |
| | | $0.4 \text{ mm} < \Phi$ | $N = 0$ |
| | Black spot | $0.2 \text{ mm} < \Phi \leq 0.4 \text{ mm}$ | $N \leq 5$ |
| | Bubble | $0.4 \text{ mm} < \Phi$ | $N = 0$ |
| | Lint | $L \leq 3 \text{ mm}$ | $N \leq 4$ |
| | | $W \leq 0.1 \text{ mm}$ | |
| $3 \text{ mm} \leq L$ | | $N = 0$ | |
| $W \leq 0.1 \text{ mm}$ | | | |
| | $0.1 \text{ mm} < W$ | According to Black spot | |
| Electrical defect | Bright dot | $N \leq 5$ | |
| | Dark dot | $N \leq 5$ | |
| | Total dot | $N \leq 8$ | |
| | Two adjacent dot | | |
| | Bright dot | $\leq 2 \text{ pairs}$ | |
| | Dark dot | $\leq 2 \text{ pairs}$ | |
| | Three or more adjacent dot | Not allowed | |
| Line defect | Not allowed | | |



Стандарт Электрон Связь

Мы молодая и активно развивающаяся компания в области поставок электронных компонентов. Мы поставляем электронные компоненты отечественного и импортного производства напрямую от производителей и с крупнейших складов мира.

Благодаря сотрудничеству с мировыми поставщиками мы осуществляем комплексные и плановые поставки широчайшего спектра электронных компонентов.

Собственная эффективная логистика и склад в обеспечивает надежную поставку продукции в точно указанные сроки по всей России.

Мы осуществляем техническую поддержку нашим клиентам и предпродажную проверку качества продукции. На все поставляемые продукты мы предоставляем гарантию .

Осуществляем поставки продукции под контролем ВП МО РФ на предприятия военно-промышленного комплекса России , а также работаем в рамках 275 ФЗ с открытием отдельных счетов в уполномоченном банке. Система менеджмента качества компании соответствует требованиям ГОСТ ISO 9001.

Минимальные сроки поставки, гибкие цены, неограниченный ассортимент и индивидуальный подход к клиентам являются основой для выстраивания долгосрочного и эффективного сотрудничества с предприятиями радиоэлектронной промышленности, предприятиями ВПК и научно-исследовательскими институтами России.

С нами вы становитесь еще успешнее!

Наши контакты:

Телефон: +7 812 627 14 35

Электронная почта: sales@st-electron.ru

Адрес: 198099, Санкт-Петербург,
Промышленная ул, дом № 19, литера Н,
помещение 100-Н Офис 331